



POWERWARE[®]
9³³⁵

*Uninterruptible Power
Supply*

*80 kVA
and
120 kVA*

**Installation and Operation
Manual**

164201396 Rev. A

IMPORTANT SAFETY INSTRUCTIONS

SAVE THESE INSTRUCTIONS

This manual contains important instructions for your Uninterruptible Power Supply (UPS) system. You should follow these instructions during the installation and maintenance of the UPS, options, accessories and batteries.

This equipment has been tested and found to comply with the limits for a Class A digital device, pursuant to Part 15 of the FCC Rules. These limits are designed to provide reasonable protection against harmful interference with the equipment is operated in a commercial environment. This equipment generates, uses, and can radiate radio frequency energy and, if not installed and used in accordance with the instruction manual, may cause harmful interference to radio communications. Operation of this equipment in a residential area is likely to cause harmful interference in which case the user will be required to correct the interference at their own expense.

Table of Contents

Introduction	viii
Basic System Configurations	ix
Using This Manual	ix
Conventions Used in This Manual	x
Safety Considerations	xi
Getting Help	xii

Section I Installation

1 Getting Started

1.1 Installing the UPS	1 - 1
1.1.1 Creating an Installation Plan	1 - 1
1.1.2 Preparing Your Site	1 - 2
1.1.3 Environmental Considerations	1 - 2
1.1.4 Preparing for Wiring the UPS System	1 - 2
1.1.5 Inspecting and Unpacking Each Cabinet	1 - 3

2 Installing the UPS System

2.1 Preliminary Installation Information	2 - 1
2.2 UPS Cabinet Installation	2 - 2
2.2.1 Unloading the Powerware 9335 (80kVA-120 kVA) UPS Cabinet from the Pallet	2 - 2
2.2.2 Installing Remote Battery Power Wiring	2 - 3
2.2.3 Installing UPS External Power Wiring	2 - 3
2.2.4 Installing Customer Connections	2 - 4
2.2.5 Prepare for Installing Accessories	2 - 4
2.3 Battery Cabinet Installation	2 - 5
2.4 Initial Startup	2 - 5
2.5 Completing the Installation Checklist	2 - 5
2.5.1 Installation Checklist	2 - 6

3 Installing and Connecting Batteries

3.1 Important Safety Instructions	3 - 1
---	-------

4 Installing a Remote EPO Control

4.1 Installation Procedures	4 - 1
4.2 To Install a Remote EPO	4 - 1
4.3 To Operate a Remote EPO	4 - 2

Section II Operation

5 Understanding UPS Operation

5.1	Looking Inside the UPS System	5 - 1
5.2	Normal, Battery and Bypass Modes	5 - 3
5.2.1	Normal Mode	5 - 4
5.2.2	Bypass Mode	5 - 6
5.2.3	Battery Mode	5 - 8
5.2.4	Maintenance Bypass Mode	5 - 10
5.3	Functional Description	5 - 11
5.3.1	Input Rectifier	5 - 11
5.3.2	Boost Converter	5 - 11
5.3.3	Inverter and Filter	5 - 11
5.3.4	Battery and Battery Charger	5 - 11
5.3.5	Static Bypass	5 - 12
5.3.6	Maintenance Bypass	5 - 12

6 Operational Controls and Features

6.1	General	6 - 1
6.2	UPS Operational Controls	6 - 2
6.2.1	Control Panel	6 - 2
6.2.2	System and Load ON/OFF	6 - 2
6.2.3	Maintenance Bypass Switch	6 - 3
6.2.4	Cold Start Capability	6 - 3
6.3	UPS Standard Features	6 - 3
6.3.1	Customer Interface	6 - 3
6.3.2	Battery Management	6 - 3
6.3.3	Installation Features	6 - 3
6.4	Options and Accessories	6 - 4
6.4.1	Remote EMERGENCY POWER OFF	6 - 4
6.4.2	Battery Cabinets	6 - 4
6.4.3	Communications	6 - 4
6.4.4	Other Options	6 - 4
6.5	Safety Considerations	6 - 5
6.6	Symbols, Controls and Indicators	6 - 6

7 Using the Control Panel

7.1	Description	7 - 1
7.2	Using the Control Panel	7 - 2
7.2.1	Power Management Display	7 - 2
7.2.2	LED Indicators	7 - 2
7.2.3	Pushbutton Functions	7 - 3
7.2.4	ON/OFF Shutdown and Startup Pushbuttons	7 - 3
7.3	Description of the LCD Screen	7 - 4
7.3.1	Status Screens	7 - 4
7.3.2	LCD Display Structure and Navigation	7 - 5
7.3.3	Main Menu Screen	7 - 6
7.3.4	Event Log Screen	7 - 6
7.3.5	Measurements Screen	7 - 6
7.3.6	Command Screen	7 - 7

7.3.7	UPS Data	7 - 8
7.3.8	Set-Up User	7 - 8
7.3.9	Set-Up Service	7 - 9
7.4	Operating Modes	7 - 10
7.4.1	“ON-LINE” Mode (Inverter Mode)	7 - 10
7.4.2	“OFF-LIINE” Mode (BYPASS or ECONOMY Mode)	7 - 10
7.4.3	“MAINTENANCE BYPASS” Mode	7 - 11
7.4.4	Parallel Isolator (IA2)	7 - 12
8	UPS Operating Instructions	
8.1	Operation	8 - 1
8.2	Start-Up Procedure for the UPS	8 - 1
8.3	Shut-Down Procedure for the UPS	8 - 3
8.4	Load Transfer to Maintenance Bypass	8 - 4
9	Responding to System Events	
9.1	Alarms	9 - 1
9.2	Menu, Commands, Event Log, Measurements	9 - 1
9.3	Fault Identification and Correction	9 - 2
10	Communications	
10.1	X – Slot Communication Modules	10 - 1
10.2	Single-Port Module	10 - 2
11	Options	
11.1	Generator ON Facility	11 - 1
12	Maintaining the UPS System	
12.1	General	12 - 1
12.2	Important Safety Instructions	12 - 1
12.3	Performing Preventive Maintenance	12 - 2
13	Product Specifications	
13.1	System Information	13 - 1
13.2	UPS System Input	13 - 1
13.3	UPS System Output	13 - 2
13.4	Environmental Specifications	13 - 2
Appendix A – Customer Information		A - 1
Warranty		W - 1

List of Figures

- Figure 1 – 1 Powerware 9335 (80 kVA and 120 kVA) UPS Cabinet
- Figure 4 – 1 Typical Remote EPO Control
- Figure 5 – 1 Main Elements of the UPS System
- Figure 5 – 2 Path of Current through the UPS in Normal Mode
- Figure 5 – 3 Path of Current through the UPS in Bypass Mode
- Figure 5 – 4 Path of Current through the UPS in Battery Mode
- Figure 5 – 5 Path of Current through the UPS in Maintenance Bypass Mode
- Figure 6 – 1 Powerware 9335 (80 kVA and 120 kVA) Controls and Indicators
- Figure 6 – 2 Powerware 9335 (80 kVA and 120 kVA) Control Panel
- Figure 7 – 1 UPS Control Panel
- Figure 7 – 2 LCD Screen and Pushbuttons
- Figure 7 – 3 LCD Screen Navigation Chart
- Figure 10 – 1 X – Slot Location on Front of Powerware 9335 UPS Cabinet
- Figure 10 – 2 The Communication Port on the Single Port Serial Card
- Figure 11 – 1 Generator ON Connection

List of Tables

Table 4 – 1	Remote EPO Wire Terminations
Table 4 – 2	Remote EPO
Table 10 – 1	Communication Port Pin Assignments

Introduction

Powerware 9335 UPS true double conversion online power protection can be utilized to prevent loss of valuable electronic information, minimize equipment downtime, and/or minimize the adverse effect on equipment production due to unexpected power problems.

The Powerware UPS System continuously monitors incoming electrical power and removes the surges, spikes, sags, and other irregularities that are inherent in commercial utility power. Working with your building's electrical system, the UPS System supplies clean consistent power that your sensitive electronic equipment requires for reliable operation. During brownouts, blackouts and other power interruptions, optional battery strings provide emergency power to safeguard your operation.

The UPS system is housed in free-standing cabinets. The cabinet sections are matching in design and color, and have safety shields behind the front panels for hazardous voltage protection. The following illustration depicts a typical Powerware 9335 (80 kVA and 120 kVA) UPS System.

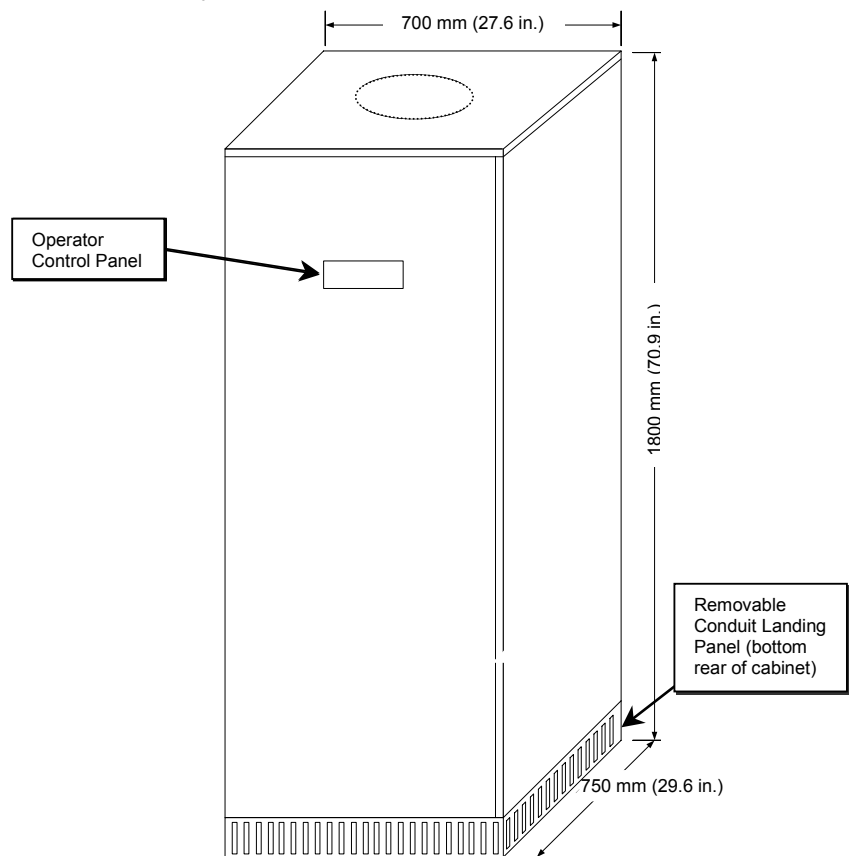

Basic System Configurations

These basic UPS system configurations are possible:

- Single Cabinet UPS with External Battery Cabinet, Single Utility Feed
- Single Cabinet UPS with External Battery Cabinet, Dual Utility Feed

You can enhance any of these system configurations by adding optional accessories, such as Remote *Emergency Power Off* (EPO) control and X-Slot communications connectivity features.

Using This Manual

Your UPS functions automatically and requires very little attention during normal operation. However, you should read and understand the procedures described in this manual to ensure trouble-free operation. In particular, you should be thoroughly familiar with the Remote Emergency Power Off procedure described in Chapter 4 of this manual.

The information in this manual is divided into the sections and chapters listed. The system you are installing dictates which parts of the manual you should read. Everyone should read the Introduction, Chapters 1, 2, 7, and 8.

Introduction

The introduction provides a brief description of the UPS system, a description of the content of each chapter, safety, and text conventions used in the manual and reference information.

Section I – Installation

- **Chapter 1 – Getting Started** – tells you how to prepare your site for the installation of your UPS system. It discusses equipment environmental requirements, inspecting, and unpacking cabinets.
- **Chapter 2 – Installing the UPS System** – describes how to install the UPS cabinets and optional equipment.
- **Chapter 3 – Installing and Connecting Batteries** – provides battery safety, installation and connection information.
- **Chapter 4 – Installing a Remote EPO Control** – contains information for installing the optional Remote Emergency Power Off (REPO) control.

Section II – Operation

- **Chapter 5 – Understanding UPS Operation** – provides information on understanding how your UPS works.
- **Chapter 6 – Operational Controls and Features** – describes the standard and optional operational features and controls of the UPS system.
- **Chapter 7 – Using the Control Panel** – describes the controls and indicators found on the Control Panel and shows the various information screens displayed on the LCD screen.
- **Chapter 8 - UPS Operating Instructions** – contains startup and shutdown procedures for the UPS system.
- **Chapter 9 – Responding to System Events** – lists all the alarm messages and notices that can occur during operation of the UPS system.
- **Chapter 10 – Communications** – describes the communication feature available with the UPS system.
- **Chapter 11 – Options** – describes the available options for this UPS system.
- **Chapter 12 – Maintaining the UPS System** – contains maintenance instructions for the UPS system.
- **Chapter 13 – Product Specifications** – provides detailed specifications for the UPS system.
- **Appendix A – Customer Information** – contains important information on wiring requirements and recommendations, and important diagrams of the cabinet’s mechanical details and electrical access.
- **Warranty** – provides the Powerware warranty for this product.

Read through each procedure before you begin. Perform only those procedures that apply to the UPS system you are installing or operating.

Conventions Used in This Manual

The text in this manual uses these conventions:

- **Bold type** highlights important concepts in discussions, key terms in procedures, and menu options.
- *Italic type* highlights notes and new terms where they are defined.
- Rectangular boxes containing bold type are warnings or cautions that pertain to the UPS system or its electrical connections.

In this manual, the term *UPS* refers only to the UPS cabinet and its internal elements. The term *UPS system* refers to the entire power protection system—the UPS cabinet, battery strings and options or accessories installed.

Safety Considerations

The UPS cabinet is designed for industrial or computer room applications, and contain safety shields behind the doors. However, the UPS system is a sophisticated power system and should be handled with appropriate care, following these guidelines:

- **Keep surroundings clean and free from excess moisture.**
- **Do not operate the UPS system close to gas or electric heat sources.**
- **The system is not intended for outdoor use.**
- **The operating environment should be maintained within the parameters stated in the manual.**
- **Keep the cabinet doors closed and locked to ensure proper cooling airflow and to protect personnel from dangerous voltages inside the unit.**
- **The UPS system contains its own power source. Lethal voltages are present even when the UPS is disconnected from utility power.**

<p>WARNING: Only AUTHORIZED SERVICE PERSONNEL should perform maintenance on or service the UPS system.</p>
--

If service or routine maintenance is required:

- **Ensure all power is disconnected before performing installation or service.**
- **Ensure the area around the UPS system is clean and uncluttered.**
- **Battery maintenance or battery replacement should be performed only by authorized service personnel.**
- **Observe all DANGER, CAUTION and WARNING notices affixed to the inside and outside of the equipment.**

Getting Help

If you need to schedule initial startup, need regional locations and telephone numbers, have a question about any of the information in this manual, or have a question this manual does not answer, please call Powerware Corporation at:

United States	1 – 800 – 843 – 9433
Canada	1 – 800 – 461 – 9166
Outside the U.S.	Call your local representative

Section I

Installation

This page left intentionally blank

Getting Started



1.1 Installing the UPS

The complete UPS cabinet is shipped on a single pallet. Use a forklift or a pallet jack, rated to handle the weight of the cabinets (refer to Table J in Appendix A for cabinet weights) to move the packaged cabinet to the installation site, or as close as possible to the site, before unloading from the pallet.

This is the basic sequence of the installation steps:

1. Create an installation plan for the UPS system. (Chapter 1)
2. Prepare your site for the UPS system (Chapter 1)
3. Inspect, unpack, and unload the UPS cabinet. (Chapter 1)
4. Wire the system. (Chapter 2)
5. Install features, accessories, and/or options, as applicable. (Chapter 4 and 10)
6. Complete the installation checklist. (Chapter 2)
7. Have authorized service personnel perform preliminary operational checks and startup.

NOTE: *Startup and operational checks should be performed only by authorized service personnel. This service is usually offered as part of the service contract for your UPS. Contact Global Services in advance (usually a two week notice is required) to reserve a preferred startup date.)*

1.1.1 Creating an Installation Plan

Before beginning to install the UPS system, read and understand how this manual applies to the system being installed. Use the procedures and illustrations in the following chapters to create a logical plan for installing the system.

1.1.2 Preparing Your Site

For your UPS to operate at peak efficiency, your installation site should meet the environmental parameters outlined in this manual. If you intend to operate the system at an altitude higher than 1500 meters (5000 feet), contact your local sales or service office for important information about high altitude operation. The operating environment must meet the weight, airflow, size and clearance requirements specified in Appendix A.

The basic environmental requirements of the UPS system are:

Ambient Temperature Range:	0 – 40°C (32 – 104°F)
Recommended Operating Range:	20 – 25°C (68 – 77°F)
Maximum Relative Humidity:	95% (non-condensing)

The UPS cabinet uses forced air cooling to regulate internal component temperature. Air inlets are in the bottom sides and front of the cabinet, and outlets in the top of the cabinet. You must allow clearance in back of the cabinet for proper air circulation. Refer to Table K of Appendix A for clearance requirements.

1.1.3 Environmental Considerations

The life of the UPS system is adversely affected if the installation does not meet the following guidelines:

1. The system must be installed on a level floor suitable for computer or electronic equipment.
2. The system must be installed in a temperature-controlled indoor area free of conductive contaminants.

Failure to follow guidelines may invalidate the UPS warranty.

1.1.4 Preparing for Wiring the UPS System

For external wiring requirements, including the minimum AWG size of external wiring, refer to Tables A and B in Appendix A for the Powerware 9335 (80 kVA and 120 kVA) UPS. The power wiring connections for this equipment are rated using copper wire at 90°C. Note that wiring to an external battery cabinet may be either 75°C or 90°C rated. Control wiring for EPO and optional accessories (such as building alarm and monitoring interface) should be connected at the customer interface connections inside the front of the UPS using class 1 wiring methods.

1.1.5 Inspecting and Unpacking Each Cabinet

The first task in preparing for installation is inspecting and unpacking the UPS. The UPS and accessory cabinets are shipped bolted to wooden pallets, as shown in Figure 1–1, and protected with outer protective packaging material.



Figure 1–1. Powerware 9335 (80 kVA and 120 kVA) UPS Packaging

1. Carefully inspect the outer packaging for evidence of damage during transit.

CAUTION:

Do not install a damaged cabinet. Report any damage to the carrier and contact your local sales or service office immediately.

2. Use a forklift or other material handling equipment to move the cabinet to a convenient unpacking area. Insert the forklift forks between the pallet supports on the bottom of the unit.

CAUTION:

Do not tilt cabinets more than ± 10 degrees from vertical.

3. Set each cabinet on a firm, level surface, allowing a minimum clearance of 3 m (10 ft) on each side for removing the cabinets from the pallets.
4. Remove accessory installation kit located at the top of the unit (see figure 1.1) by opening top of outer box.

CAUTION:

If accessory kit is not moved, box will be top heavy upon removal. Approximate weight of accessory kit is 25 lbs. (11 kg.)

5. Remove the protective covering from the cabinets.
6. Remove the packing material, and discard or recycle them in a responsible manner.
7. After removing the protective covering, inspect the contents for any evidence of physical damage, and compare each item with the Bill of Lading. If damage has occurred or shortages are evident, contact the Powerware Customer Service Department immediately to determine the extent of the damage and its impact upon further installation.

NOTE: *While awaiting installation, protect the unpacked UPS cabinet from moisture, dust, and other harmful contaminants. Failure to store and protect the UPS properly may invalidate the warranty.*

Installing the UPS System

2.1 Preliminary Installation Information

WARNING:

Only qualified personnel should perform installation. All wiring and installation of the UPS system must be done in accordance with the most current NEC standards or local electrical code.

Refer to the following while installing the UPS system:

- Refer to Appendix A of this manual for installation drawings and additional installation notes.
- Dimensions in this manual, unless otherwise noted, are in millimeters and (inches).
- Do not tilt the cabinets more than ± 10 degrees during installation.
- The conduit landing plates are to be removed to add conduit landing holes as required. Plate material is 14 gauge steel (2 mm. thick)
- The cabinets must be installed on a level floor suitable for computer or electronic equipment.
- If perforated floor tiles are required for ventilation, place them in front of the UPS. Refer to Table J in Appendix A for equipment weight and point loading, and Figure A-5 in Appendix A for air inlet locations.
- Details about control wiring are provided in each procedure for connecting options and features. Figure A-1 and Tables G and H in Appendix A identify the control wiring terminations.

2.2 UPS Cabinet Installation

To install an UPS cabinet, perform the procedures in the following paragraphs.

2.2.1 Unloading the Powerware 9335 (80 kVA and 120 kVA) UPS Cabinet from the Pallet

The UPS cabinet is bolted to a wooden shipping base using two steel angles. To remove the shipping material, perform the following procedure.

WARNING:

The UPS cabinet is heavy. Refer to Table J in Appendix A for weight of cabinets. If unloading instructions are not closely followed, the cabinet may cause serious injury.

CAUTION:

Do not tilt cabinets more than ± 10 degrees from vertical. Do not cut the outside protective cardboard packing box open. Damage to the enclosed cabinet may occur.

CAUTION:

Carefully open top of outer package and remove accessory installation kit before removing outer packaging. Approximate weight is 25 lbs. (11 kg.)

1. Remove accessory installation kit located at the top of the unit (see figure 1.1) by opening top of outer box. **Remove the 4 jacking bolts from the accessory pack.** Use a forklift or other material handling equipment to move the cabinet to the installation area. Insert the forklift forks under the unit and keep the unit elevated approximately 3 inches above the ground.
2. Remove the outer stretch wrapping. The two steel angles which connect the UPS cabinet to the wooden shipping base contain 2 threaded holes for inserting jacking bolts..
3. Unbolt the wooden cross members on the shipping base by removing the four nuts (10 mm) which fasten the wooden pallet to the steel brackets. Remove the wooden cross members from the steel brackets. Insert the jacking bolts into the holes and lower them to the ground, in order for the weight of the unit to be supported by the 4 bolts. Place small metal plates under the jacking bolts to prevent floor damage. Ensure the unit does not tilt more than specified in the caution note above. Remove the forklift or pallet jack once the unit is supported on the jacking bolts. Slowly lower the UPS by alternating between the four jacking bolts, until the steel brackets are on the floor. Remove the jacking bolts. Detach the UPS cabinet from the angle steel by removing all of the M5 Phillips-head machine screws that fasten them, using a #3 Phillips head screwdriver. Tilt the unit slightly to enable the steel bracket to be removed from beneath two legs. Lower the unit down to the floor.
4. Repeat the process for the other side by tilting the unit and removing the steel bracket. (See illustrated procedure packed on the outside of the shipping carton.)
5. The UPS cabinet may now be moved to its final position for installation.

2.2.2 Installing External Battery Power Wiring

The Powerware 9335 contains no internal batteries and must therefore be used with an external battery system. The procedure for wiring the battery system to the 9335 is described as follows. Also read the manual provided with the battery system to ensure proper interconnections on the battery side.

1. If not already done, open the UPS cabinet door using the provided operator handle and remove the bottom internal protective panel. Retain hardware.

NOTE: Remove the UPS cabinet conduit landing plate to punch out conduit holes.

2. Route battery cables from the battery cabinet through the conduit landing plate at the UPS cabinet bottom rear to the battery terminals at the bottom front of the cabinet. Refer to Appendix A of this manual for wiring access information.

NOTE: Remove the UPS cabinet input and output conduit landing plate to punch conduit holes as required. When reinstalling, ensure that the protective ground wire is reconnected if it has been removed for conduit hole punching in the plate.

3. Connect positive, negative and neutral DC power wiring from the external battery source to the DC input (positive and negative) and neutral (battery center tap) terminals in the UPS cabinet. Refer to Appendix A of this manual for wiring and termination requirements and wiring access information.

2.2.3 Installing UPS External Power Wiring

1. Open the front cabinet door using the provided removable operator handle (packed separately with the UPS). Remove the internal safety shield panel by removing the fastening hardware to gain access to the input and output terminals at the bottom front of the cabinet.

NOTE: Remove the UPS cabinet input and output conduit landing plate to punch conduit holes as required. When reinstalling, ensure that the protective ground wire is reconnected if it has been removed for conduit hole punching in the plate.

2. Route input and output cables through wireway to UPS terminal blocks. Refer to Appendix A of this manual for wiring access information.
3. For bypass input or single feed, connect phase A, B, C, Neutral (N) and earth ground (G) input power wiring from the source to the bypass input terminals (2A, 2B, 2C) in the UPS cabinet. Refer to Appendix A of this manual for wiring and termination requirements and wiring access information. Note wiring connections for single feed systems.

DANGER:

Never connect the earth ground (G) to the Neutral connection (N) inside the UPS equipment cabinet. Never connect input and output neutrals (N) together. A serious electric shock hazard or equipment failure could result.

WARNING:

The Powerware 9335 UPS requires a neutral input power connection for proper operation. Internal input and output neutrals are permanently connected inside the cabinet.

WARNING:

An insulated grounding conductor must be provided per NEC.

4. If the installation is for a single utility feed with common rectifier and bypass input, proceed to step 7. For a separate bypass and rectifier input, proceed to step 5.
5. Remove the single feed bus bar jumper connections from between X6 and X7, Phase A, B, and C and discard them. They will not be used again.
6. Connect ground, phase A, B, C, and Neutral mains input power wiring from the source to the Mains input terminals (1A, 1B, 1C) on the In/Out Terminal Block. Phase A input connects to input terminal 1A, phase B to input terminal 1B and phase C to input terminal 1C. Refer to Appendix A of this manual for wiring and termination requirements and wiring access information. Note wiring connections for dual feed systems.
7. Connect ground, phase A, B, C, and Neutral power wiring from the output terminals (3A, 3B, 3C) on the In/Out Terminal Block to the critical load. Output terminal 3A connects to phase A of the load, output 3B to phase B and output 3C to phase C, respectively. Refer to Appendix A of this manual for wiring and termination requirements and wiring access information.
8. Secure the UPS by reinstalling the safety shield panels, and closing the front cabinet door, latching the cabinet door with the removable door handle.

2.2.4 Installing Customer Connections

See Chapter 10, "Communications"

2.2.5 Prepare for Installing Optional Accessories

NOTE: *If you are installing accessories, including the Remote Emergency Power Off (REPO) switch, you must install conduit between each device and the UPS cabinet for wiring these options.*

1. Be sure the UPS system is turned off and all power sources are removed. (See the operation section of this manual for shutdown instructions.)

2. Remove Customer Interface conduit landing plate from the UPS cabinet. Drill or punch conduit holes for interface wiring.
3. Open UPS cabinet front door and remove the front safety shield panel to gain access to the wire way to bring wires from the conduit landing panel at the bottom rear of the cabinet.
4. Locate required connection points by referring to Figure A–1 in Appendix A.
5. Refer to Appendix A of this manual for wiring and termination requirements.
6. Reinstall Customer Interface conduit landing plate.
7. Install conduit and wiring.
8. When wiring is complete, secure UPS by reinstalling all panels removed in previous steps.

2.3 Battery Cabinet Installation

The Powerware 9335 has no batteries within the UPS cabinet. An external battery cabinet with appropriate batteries installed is required for proper system operation. See installation instruction provided with the battery cabinet for proper installation of that portion of the system.

WARNING:

It is very important to ensure that a proper protective device is installed between the battery system and the UPS DC input terminals. See Tables A and B in Appendix A for proper wire and protective device sizing.

2.4 Initial Startup

Startup and operational checks should be performed only by authorized service personnel. Contact service in advance (usually a two week notice is required) to reserve a preferred startup date.

2.5 Completing the Installation Checklist

The final step in installing your UPS system is completing the following Installation Checklist. This checklist ensures that you have completely installed all hardware, cables, and other equipment. Completing all items listed on the checklist will ensure a smooth installation. You should make a copy of the Installation Checklist before filling it out, and retain the original.

After your installation is complete, a service representative will be able to verify the operation of your UPS system and commission it to support your critical load. The service representative cannot perform any installation tasks other than verifying software and operating setup parameters. Service personnel may request a copy of the

completed Installation Checklist to be sure you have completed all applicable equipment installation.

NOTE: *The Installation Checklist MUST be completed prior to starting the UPS system for the first time.*

2.5.1 Installation Checklist

- All packing materials and restraints have been removed from each cabinet.
- Each cabinet in the UPS system is placed in the installed location.
- All conduits and cables are properly routed to the UPS and auxiliary cabinets.
- All power cables are properly sized and terminated.
- All network connections have been completed.
- A ground conductor is properly installed.
- Battery cabinet installation instructions have been completed.
- Air conditioning equipment is installed and operating properly.
- The area around the installed UPS system is clean and dust-free. (It is recommended that the UPS be installed on a level floor suitable for computer or electronic equipment.)
- Adequate workspace exists around the UPS and other cabinets.
- Adequate lighting is provided around all UPS equipment.
- Any optional accessories are mounted in their installed location and properly wired.
- Summary alarms and/or building alarms are wired appropriately. (OPTIONAL)
- Startup and operational checks performed by authorized service personnel.

Installing and Connecting Batteries

3.1 Important Safety Instructions

The Powerware 9335 UPS does not contain batteries. It must, however, be used with a properly configured battery cabinet or rack with a properly sized battery system for proper operation.

The installation of batteries should be performed or supervised by personnel knowledgeable of batteries and their associated precautions. Keep unauthorized personnel away from batteries.

CAUTION:
Refer to the battery manufacturers installation manual for battery installation and maintenance instructions.

This page left intentionally blank

Installing a Remote EPO Control

4.1 Installation Procedures

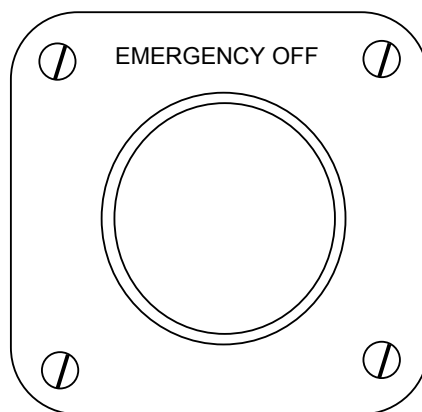

Figure 4–1. Typical Remote EPO Control

4.2 To Install a Remote EPO:

NOTE: Before installing a Remote EPO, be sure you have prepared the UPS according to the instructions in Chapter 2.

To Install a Remote EPO control:

1. Securely mount the remote EPO switch. Recommended locations include near operator's consoles or near exit doors. Refer to Remote EPO switch manufacturers installation instructions for enclosure dimensions and wiring knockouts.
2. Install wiring from the remote EPO switch using appropriate sized conduit through the Customer Interface conduit landing plate on the bottom rear of the UPS cabinet. Refer to Figure A-10 for conduit landing area,
3. Connect the Remote EPO wiring as shown in Tables 4–1 and 4–2.

Table 4 – 1. Remote EPO Wire Terminations		
<i>From Remote EPO Switch(s)</i>	<i>To X1 connector on front of inner UPS panel</i>	<i>Remarks</i>
Refer to switch manufacturers installation instructions	X1 - 1	Twisted wires (2) 14-18 gauge
	X1 - 2	

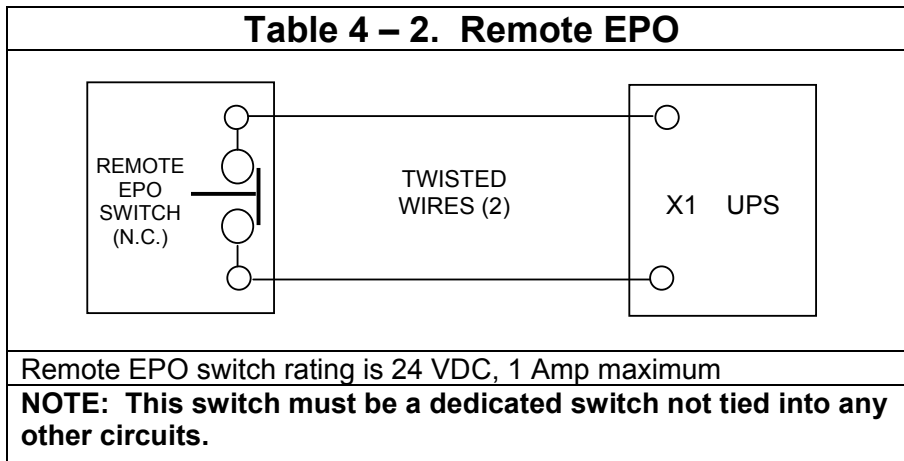

4. If you are installing multiple Remote EPO stations, wire additional stations in series with the first Remote EPO.
5. If required, install appropriate sized conduit and wiring from the Remote EPO switch to trip circuitry of upstream protective devices. A separate contact block, with the appropriate normally open or normally closed contacts, must be used for this function. Remote EPO switch wiring must be in accordance with UL Class 1 requirements.
6. Secure the UPS by reversing all steps taken to prepare it for Remote EPO installation.

4.3 To Operate a Remote EPO:

1. Activation of an EPO switch will interrupt the EPO circuit and immediately shut off UPS main circuit power to the load, as well as the DC input from the battery supply.
2. Even though the EPO switch is opened, the UPS will not re-energize until the normal startup procedure is followed, which requires operator intervention at the UPS cabinet controls.

Section II

Operation

This page left intentionally blank

Understanding UPS Operation

5.1 Looking Inside the UPS System

The Powerware 9335 is a continuous duty, solid-state, transformerless (at 480 VAC) three phase, true online system that provides conditioned and uninterruptible AC power to the UPS systems output. The UPS supports process control, data processing, telecommunications/PBX, and research equipment. The Powerware 9335 maintains power to the critical loads during commercial electrical power brownout, blackout, overvoltage, undervoltage and out-of-tolerance frequency conditions.

The basic system consists of a:

- rectifier
- battery charger
- DC booster
- Inverter
- monitoring/operation control panel
- integrated communications server
- microprocessor controlled logic

In this manual, the power required by your equipment is called the *critical load*. The UPS supplies the critical load with conditioned power that is synchronized with your utility power. Figure 5–1 shows the main elements of the UPS.

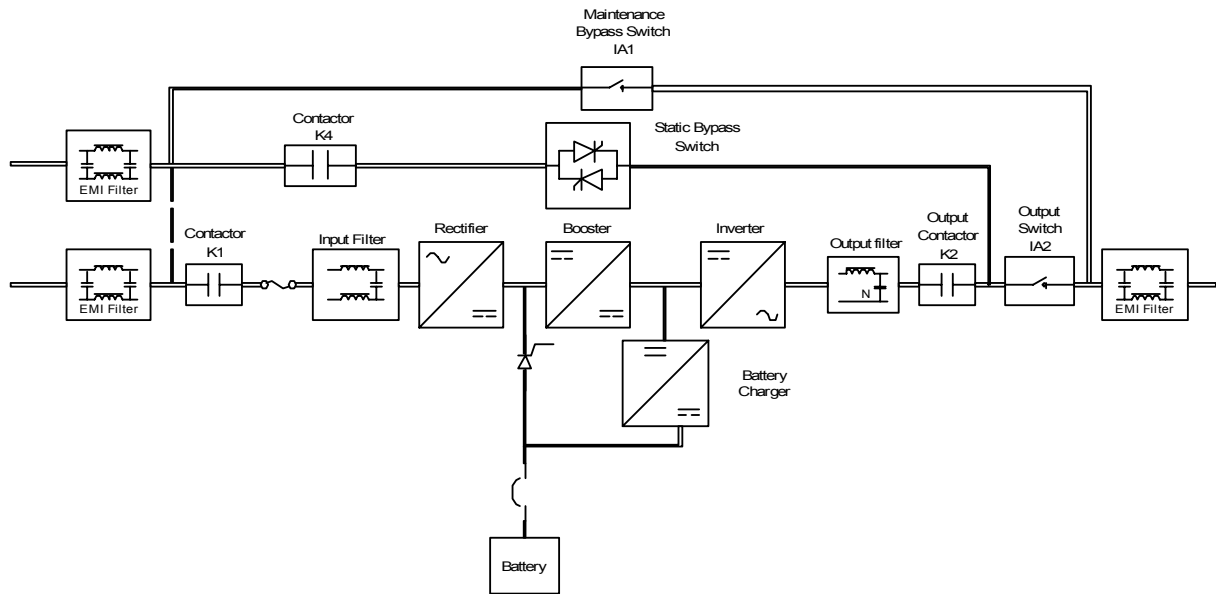

Fig. 5–1. Main Elements of the UPS System

If utility power is interrupted or falls outside the parameters specified in Chapter 13, “Product Specifications,” the UPS uses a *backup battery supply* to maintain power to the critical load for a specified period of time or until the utility power returns. For extended power outages, the UPS is designed to operate with an alternative power system (such as a generator) or will shut down your critical load in an orderly manner, if Powerware shutdown software is used.

In the event of a severe output overload or failure of a critical internal UPS component, an emergency bypass, consisting of a continuous duty static switch, and backfeed protection contactor (K4) is utilized. The backfeed protection contactor is located in series with the static switch, to ensure safety to anyone working upstream of the UPS system. For manual transfers to bypass, the static switch is also used. The static switch is armed and ready during both types of transfers.

If maintenance of the UPS system is required, an internal Maintenance Bypass switch provides a means of isolating the UPS Rectifier/Booster/Inverter components for servicing, while still supplying power to the critical load.

The operation of the UPS is described in greater detail in the following paragraphs.

5.2 Normal, Battery and Bypass Modes

The UPS system functions automatically to supply AC electrical power to the critical load. There are four standard operation modes.

- In Normal mode, the critical load is supplied by the inverter, which derives its power from rectified utility AC power. In this mode, the battery charger also provides charging current for the battery, if needed.
- In Battery mode, the critical load is supplied by the inverter which derives its power from the battery DC power.
- In Bypass mode, the critical load is directly supported by utility power via the static switch. In this mode, the critical load is not protected.
- In Maintenance Bypass mode, the critical load is directly supported by utility power, but the UPS can be shut down for maintenance. The operator switching the Maintenance Bypass Switch to the Bypass position accomplishes this, however, the critical load is not protected.

The UPS continually monitors itself and the incoming utility power, and automatically switches between these modes as required, with no operator intervention, except for the Maintenance Bypass mode. The sophisticated detection and switching logic inside the UPS ensures that operating mode changes are automatic and transparent to the critical load.

System events are *alarms* and *notices* that are displayed on the LCD monitor panel. They may or may not require operator intervention. See Chapter 9.

The following descriptions provide the differences in UPS operating modes.

5.2.1 Normal Mode

Figure 5–2 shows the path of electrical power through the UPS system when the UPS is operating in Normal mode.

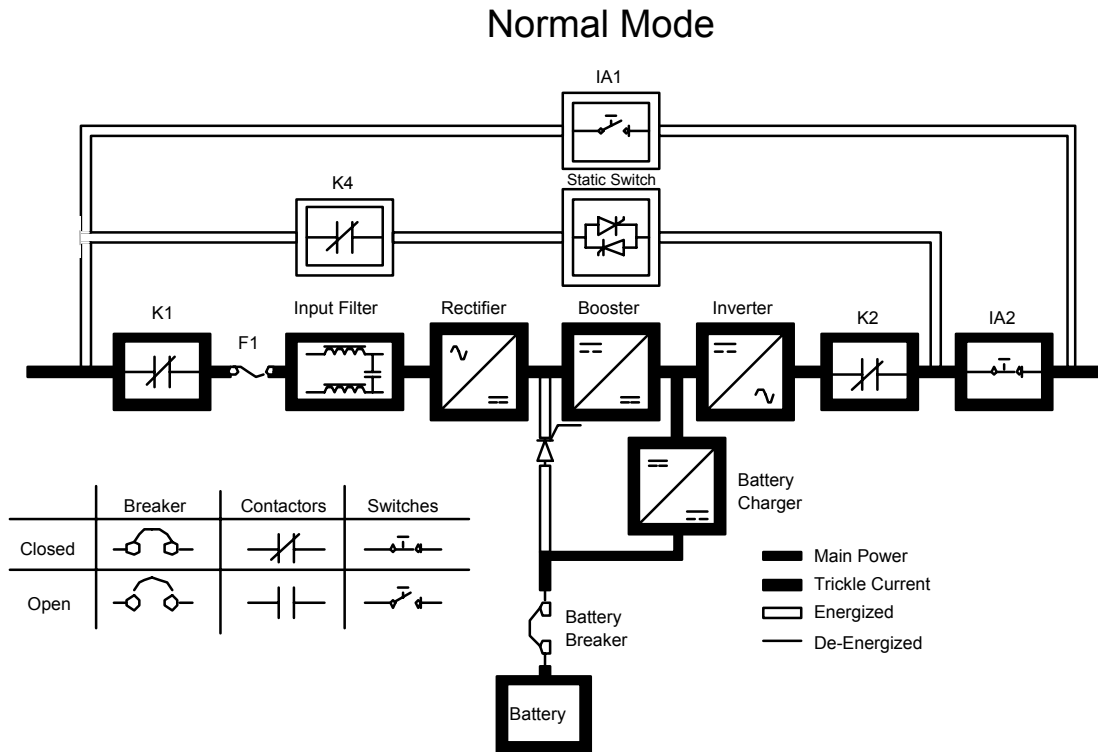

Figure 5–2. Path of Current Through the UPS in Normal Mode

During normal UPS operation, power for the system is derived from a utility input source through the input contactor K1 (and externally protected utility feed). “Load Protected” appears on the LCD display and indicates the incoming power is within voltage and frequency acceptance windows. Three phase AC input power is converted to DC using a full-wave, six-pulse, solid-state rectifier block which supplies unregulated DC voltage to a boost converter which in turn supplies a higher, regulated DC voltage to the inverter.

A separate internal battery charger is used to maintain the proper charge level on the battery during normal operation. The battery charger derives its input from the booster output and provides regulated DC voltage and charge current to the battery. The battery charge condition is monitored by the UPS and, when abnormal, reported by the status indicators located on the LCD display. The battery is always connected to the UPS and ready to support the inverter should the utility input become unavailable.

The DC boost converter derives power from the unregulated DC rectifier and produces a higher, stable DC voltage and current source for the inverter. A fixed system neutral is also carried through the boost converter to allow full support of single phase AC loads from any phase of the inverter output. The output neutral of the system is connected to the required neutral, both from the main utility supply and the bypass supply and should never be bonded to protective earth ground at the UPS output.

The inverter produces three phase AC power to a customer load without the use of a transformer. The inverter derives power from the boost converter regulated DC and utilizes IGBT devices and pulse-width modulation (PWM) to produce a regulated and low harmonic content AC output. The AC output of the inverter is delivered to the system output through the output contactor K2.

If the utility AC power is interrupted or is out of specification, the UPS automatically switches to Battery mode to support the critical load with no interruption. When utility power returns, the UPS returns to normal mode.

If the UPS becomes overloaded or unavailable, the UPS switches to Bypass mode. The UPS automatically returns to Normal mode when the overload condition is cleared and system operation is restored within specified limits.

If the UPS experiences an internal failure, it switches automatically to Bypass mode and remains in that mode until the failure is corrected and the UPS is back in service.

5.2.2 Bypass Mode

The UPS automatically switches to Bypass mode if it detects an overload, load fault, or internal failure. The bypass source supplies the commercial AC power to the load directly.

Figure 5–3 shows the path of electrical power through the UPS system when operating in the Bypass mode.

CAUTION:
The critical load is not protected while the UPS is in the Bypass mode.

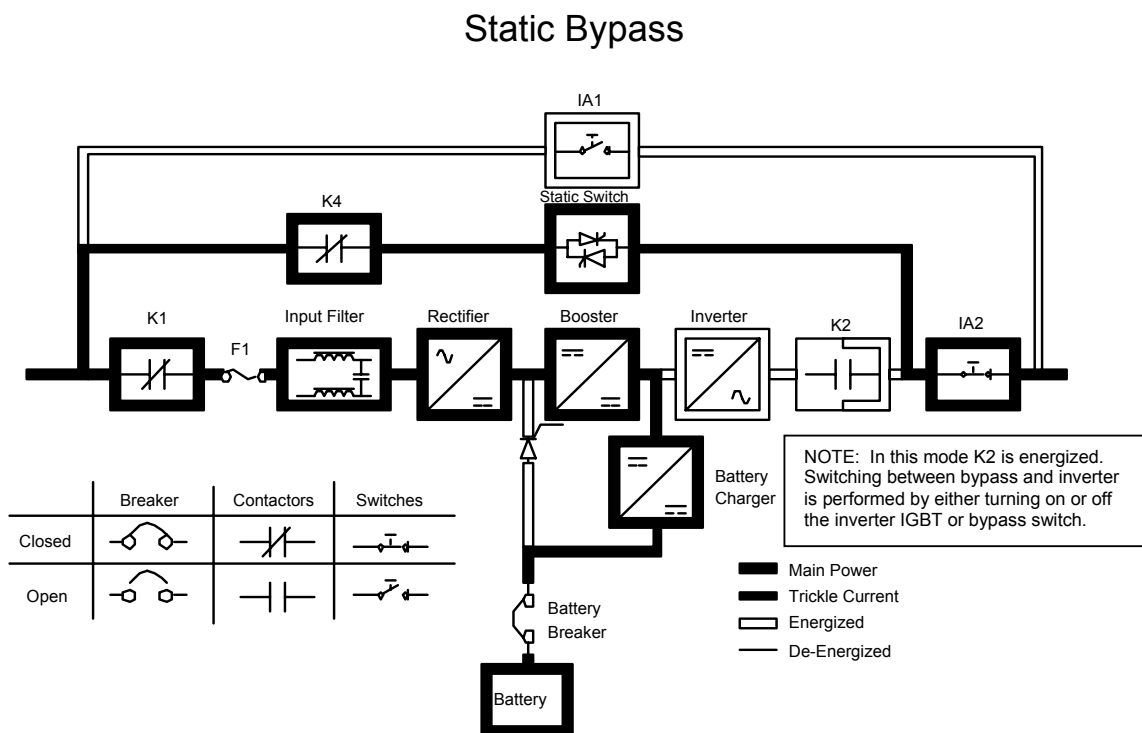

Figure 5–3. Path of Current Through the UPS in Bypass Mode

In BYPASS mode, the output of the system is provided with three phase AC power directly from the systems input. While in this mode, the output of the system is not protected from voltage or frequency fluctuations or power outages from the source. Some power line filtering and spike protection is provided to the load but no active power conditioning or battery support is available to the output of the system in the bypass mode of operation.

The internal bypass is comprised of a solid state silicon controlled rectifier (SCR) static switch (SSW), and a back feed protection contactor (K4). The static switch is rated as a continuous duty device that is used anytime the boost converter and inverter is unable to support the applied load. The static switch is wired in series with the back feed protection

contactor and together are wired to enable the inverter and rectifier to be bypassed when this path is active. The static switch, as an electronically controlled device, can be turned on immediately to pick up the load from the inverter. The backfeed protection contactor is normally always closed, ready to support the static switch unless the bypass input source becomes unavailable.

During an outage, transfers to bypass are prohibited and for the safety of those who may be working on the power lines upstream from the UPS, the back feed protection contactor is opened, preventing system output voltage from bleeding across the static switch snubber components to the bypass input source. In the bypass mode, which can be used for higher efficiency operation, the static switch is turned on to supply the load current directly from the bypass supply, with the inverter ready to take over the load if the bypass supply should vary outside preset limits.

If the inverter is unable to support the load on the output of the system, the UPS will transfer the critical load to the internal bypass. The critical load will be transferred automatically to the internal bypass if any of the following abnormal conditions occur on the output of the system: If the output of the system exceeds acceptable voltage tolerances; Critical load current exceeds the overload specifications of the inverter; Inverter failure. The transfer is initiated by turning on the static switch and blocking the IGBT gate signal. This kind of transfer is normally referred to as a Make-Before-Break transfer. The transfer takes place in less than 4 ms (one-quarter cycle) to ensure loads on the systems output are not interrupted. The static switch remains on until either the inverter is able to support the system output or the unit is placed into a maintenance position where repairs can be made.

If the UPS initiates its own transfer to bypass for any reason other than operator intervention, the UPS will attempt to restart the inverter (if not running already) and attempt a retransfer back on line to support the output of the system. Three attempts will be made within ten minutes to bring the inverter back on-line automatically before the UPS will lock out any further attempts. After three attempts have been made, the UPS will remain in bypass and an alarm condition will be annunciated. The UPS can also be transferred to bypass using the front panel controls.

Bypass mode is a normal operating mode, not requiring an alarm condition. However, if the UPS is unable to return to Normal mode following an automatic transfer to Bypass mode, an alarm condition is recorded.

5.2.3 Battery Mode

The UPS transfers to battery mode automatically if a utility power outage occurs, or if the utility power does not conform to specified parameters. In Battery mode, the battery provides emergency DC power that the inverter converts to AC power.

Figure 5–4 shows the path of electrical power through the UPS system when operating in Battery mode.

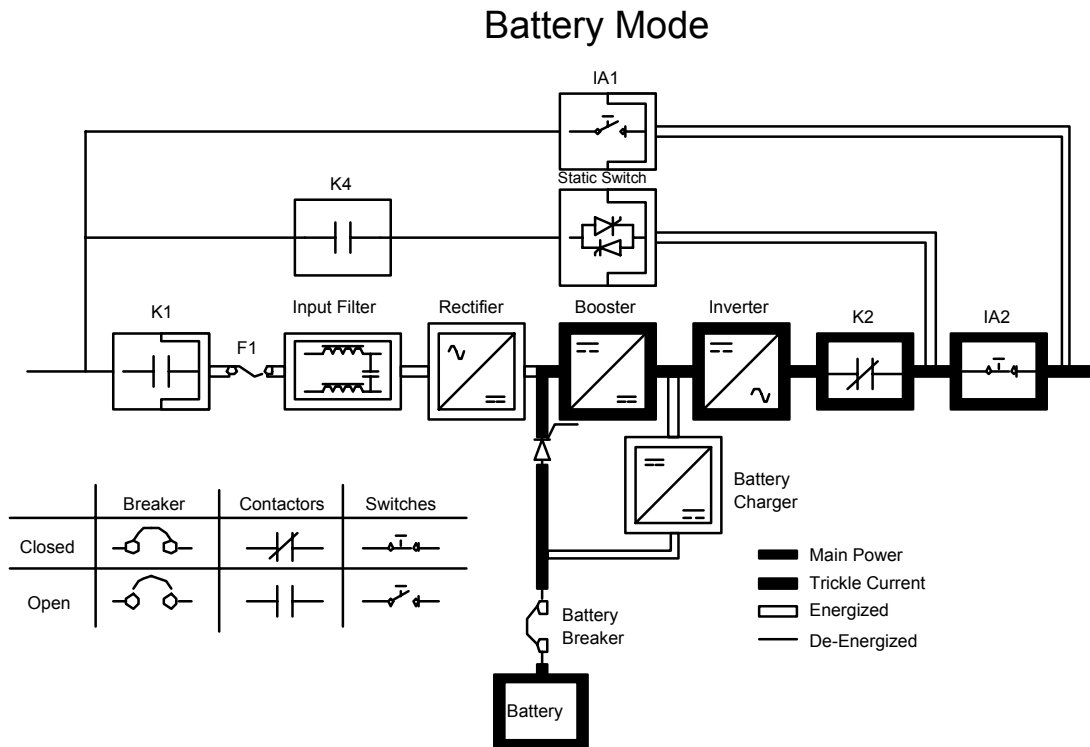

Figure 5–4. Path of Current Through the UPS in Battery Mode

During a utility power failure, the rectifier no longer has an AC utility source from which to supply the DC output current required to support the battery charger and boost converter. The input contactor (K1) is opened, the battery charger is turned off, and the battery SCRs (+ and -) both receive signals to turn on to provide battery power to the system. Because the battery SCRs are electronic devices, battery power is instantly available to the boost converter so that the inverter and customers load can be supported without interruption. In a single feed installation, where the bypass input is connected to the rectifier input, the back feed protection contactor (K4) will also open. The opening of contactors K1 and K4 prevents static system voltage from bleeding backwards through the static switch and rectifier snubber components and re-energizing the input source.

While in battery mode, the UPS will enunciate an audible horn, indicate the status change on the front panel display with the message "MAINS NOT OK", and make an entry into the alarm event history. As the battery discharges, the boost converter and inverter constantly make small adjustments to ensure a steady output. The UPS will remain in this operating mode until the input power to the rectifier is again within the specified voltage or frequency acceptance window.

If the input power fails to return or is not within the acceptance parameters required for normal operation, the battery will continue discharging until a DC voltage level is reached where the inverter output can no longer support the connected loads. When this occurs, the unit will issue another set of audible and visual alarms indicating "BATTERY IN DISCHARGE". Unless the rectifier has a valid input soon, the critical load will only be supported for about 3 minutes before the output of the system shuts down completely. When this occurs, the LCD display will show the message "BATTERY DISCHARGED".

If at any time during the battery discharge, the input power becomes available again, contactors K1 and K4 are closed and the rectifier will begin to supply DC current to the boost converter and inverter. The battery SCRs will be switched off while the battery charger is turned back on to begin recharging the battery. At this point, the unit returns to normal operation.

The systems total operating time on battery will depend on many factors. Some factors that affect battery support times are battery type and capacity, number of parallel strings, environmental temperatures, age of the battery, and fluctuations in load demand during the discharge. The greater the load, the less support time the battery will provide. Decrease the load and the battery support time will generally increase.

5.2.4 Maintenance Bypass Mode

An internal maintenance switch (IA1) is used to safely supply utility power to the system output during periods of maintenance or repairs. Before this switch is used, the system should be transferred to bypass. This switch has two positions: “O” (OFF) and “I” (ON). When switched to “I” (ON), the bypass source supplies the commercial AC power to the load directly.

While on internal (static) bypass, when a user rotates the maintenance switch from the “O” (OFF) to the “I” (ON) position, the load is wrapped around the UPS, and power is removed from the entire upper portion of the UPS allowing service work to be completed on the UPS safely.

Figure 5–5 shows the path of electrical power through the UPS system when operating in Maintenance Bypass mode.

CAUTION:
The critical load is not protected while the UPS is in the Maintenance Bypass mode.

DANGER:
LETHAL VOLTAGE PRESENT: This unit should not be operated with the cabinet doors open or protective panels removed. Do not make any assumptions about the electrical state of any cabinet in the UPS system.

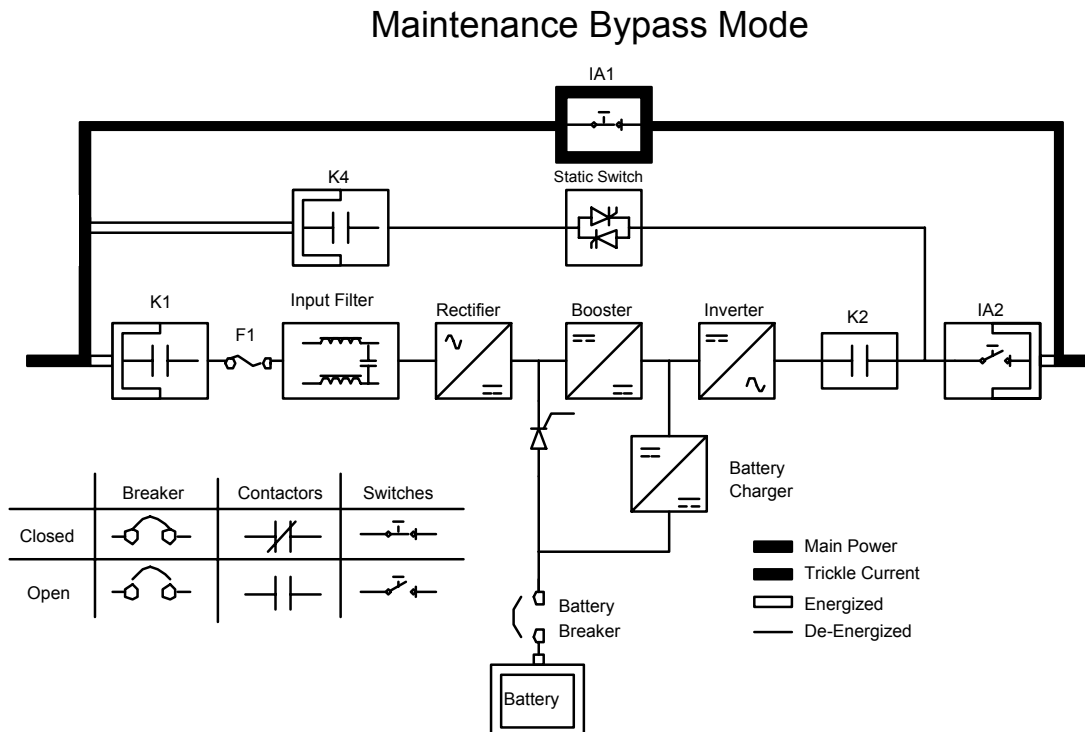

Figure 5–5. Path of Current through the UPS in Maintenance Bypass Mode

5.3 Functional Description

The UPS is an online double-conversion unit with a series power train. An uncontrolled rectifier feeds a boost converter, which in turn powers the inverter. The internal static bypass utilizes a static switch and an independent maintenance bypass switch is also included internal to the UPS cabinet. The unit input must be 4-wire in (plus ground) at the rectifier and 4-wire in (plus ground) at the bypass. The output can be either 4-wire plus ground or 3-wire plus ground depending on customer requirement. The unit does not incorporate any galvanic isolation, input to output. The battery string comprises 240 cells (480 volts nominal) arranged in a positive string of 120 cells and a negative string of 120 cells with the center of the series connected strings tied to system neutral, for the 80 kVA model. The 120 kVA model utilizes 144 cells on each side of the center connection (nominal 288 volts positive and negative, for 576 volts total). The battery is charged by positive and negative side chargers, which are powered from the output of the boost converter.

5.3.1 Input Rectifier

The Input Rectifier is a full wave bridge uncontrolled rectifier, which produces unregulated DC of approximately +390 and –390 volts DC. A pre-charge system charges the DC bus prior to the input contactor being closed, to control inrush current to no higher than rated current levels.

5.3.2 Boost Converter

A Boost Converter converts the raw DC input to a regulated DC link voltage of approximately +450 and –450 volts DC. It is operated in the current mode and is controlled using a variable modulation technique with a frequency in the range of 20 kHz. The neutral connection is maintained from the input to the output as a fixed connection.

5.3.3 Inverter and Filter

The inverter is a traditional (current mode controlled) hard-switched IGBT 3-phase topology. The IGBTs are modulated by a variable frequency, current-mode control technique at approximately 20 kHz. An output filter filters out the high frequency switching components (line to neutral).

5.3.4 Batteries and Battery Charger

The battery for the Powerware 80 kVA system is comprised of a positive string of 120 cells and a negative string of 120 cells, each made up of twenty 12-volt battery blocks. For the Powerware 120 kVA system, the battery strings are 144 cells positive and negative, respectively. The battery charger is divided into a positive side charger and a negative side charger, each powered from the respective positive and negative controlled DC bus voltages. The chargers operate automatically in the constant current

or constant voltage mode (temperature compensated, available as an option) based on battery condition.

All batteries used in conjunction with the Powerware 9335 are external to the UPS cabinet. The internal charger charges the entire battery system, with a maximum current as indicated in Chapter 13, "Product Specifications". Note that the higher the battery capacity, the longer the recharge time required to fully recharge the batteries.

5.3.5 Static Bypass

The bypass has a continuous-duty SCR switch and a back-feed contactor (K4) in the Bypass circuit. In normal mode, the contactor connects the inverter to the output. A contactor (K2) provides isolation to the inverter when the system is on bypass.

5.3.6 Maintenance Bypass

A user accessible shrouded 4-wire Mechanical Maintenance Bypass switch is provided internal to the cabinet.

Operational Controls and Features

6.1 General

The UPS system should function automatically and require very little attention during normal operation. The controls and indicators identified in this section are used during startup to monitor normal operation and during abnormal events.

Figure 6–1 identifies and shows the location of the controls and indicators on the Powerware 9335 (80 kVA and 120 kVA) UPS. The descriptions provide a brief overview of the UPS controls, and standard and optional features.

NOTE: Read the Operation section of this manual and have thorough knowledge of UPS operation before attempting to operate any of the UPS controls or optional components.

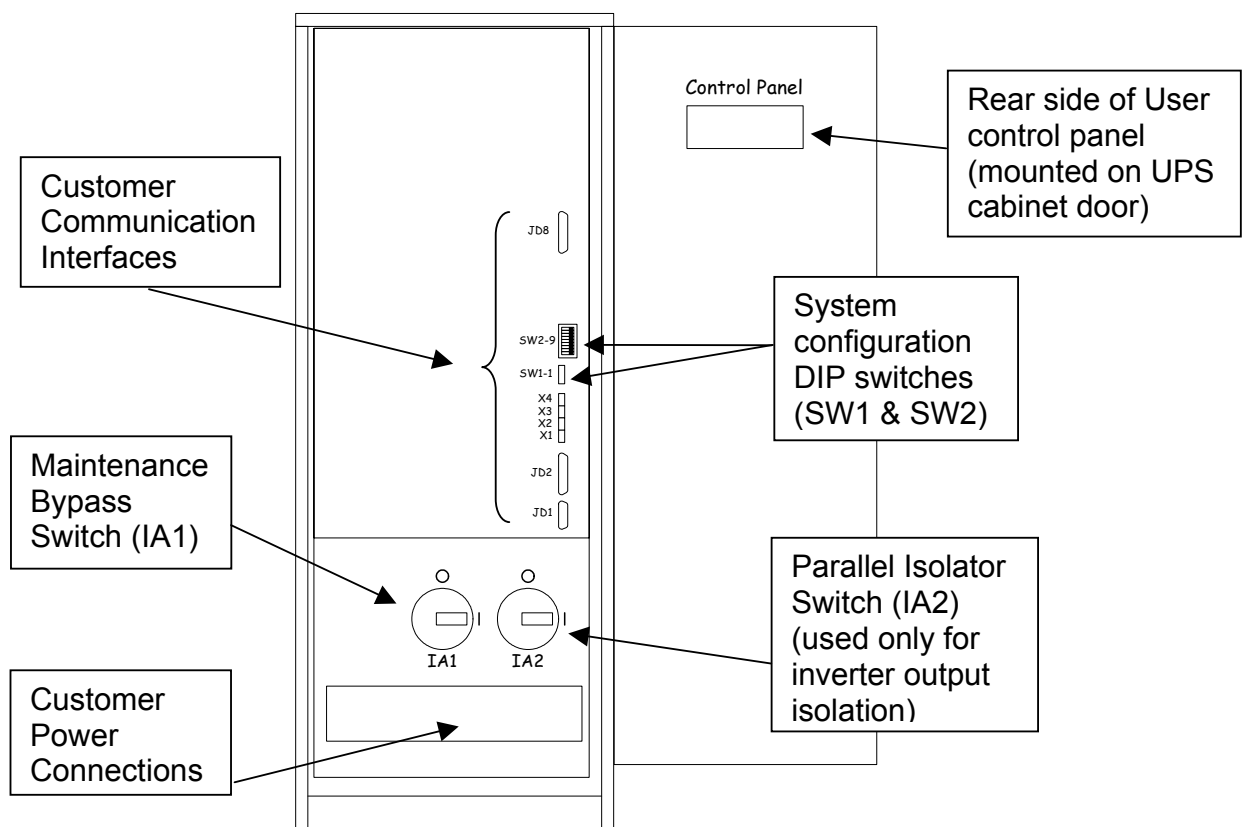

Figure 6–1. Powerware 9335 (80 kVA and 120 kVA) Controls and Indicators

6.2 UPS Operational Controls

The UPS has many standard features that provide cost effective and consistently reliable power protection.

6.2.1 Control Panel

The *Control Panel* on the front of the UPS, pictured in Fig. 6–2, contains a LCD screen to display the current status of the UPS system. You can view a statistical history and log of system events and display a real-time representation of power flow through the system components. LED status indicators show the operating mode of the UPS and alert you to system events. Panel push buttons provide navigation through the information and control screens. The load ON/OFF pushbuttons are located at the right of the control panel. Both must be pressed simultaneously to activate the LOAD ON/OFF function. Below the LCD screen are the user control pushbuttons, RESET, UP, DOWN, and ENTER, which provide access to the control and measurement functions of the UPS. The control panel is described in detail in chapter 7, “Using the Control Panel”.

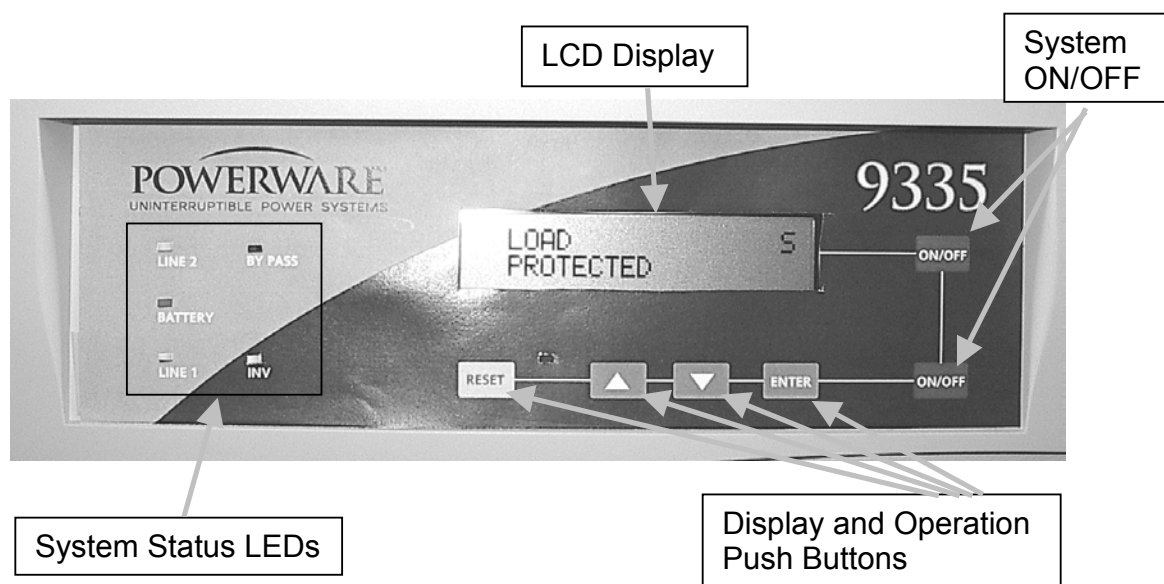

Figure 6–2. Powerware 9335 (80 kVA and 120 kVA) Control Panel

6.2.2 System and Load ON/OFF

Two load ON/OFF pushbuttons are located on the right side of the LCD display. Activating both pushbuttons simultaneously will effect immediate system shutoff. This feature prevents accidental system shutdown if one of the pushbuttons is inadvertently depressed. System turn on is achieved in the same manner, by simultaneously depressing both buttons. Operation of the system ON/OFF pushbuttons is described in detail in Chapter 7, “Using the Control Panel” and Chapter 8, “UPS Operating Instructions.”

6.2.3 Maintenance Bypass Switch

An internal Maintenance Bypass Switch is provided to completely isolate the main power processing of the UPS during service. The Maintenance Bypass Switch is described in detail in Chapter 8, "UPS Operating Instructions."

6.2.4 Cold Start Capability

The 9335 UPS system cannot be powered up without a utility input initially present. Accordingly, it is not able to power a load if the system is not started first on utility power.

6.3 UPS Standard Features

6.3.1 Customer Interface

Computer Interface

One serial communications port, using the standard Powerware XCP interface, is provided via a plug-in interface card inserted in the communications slot on the front of the unit. This interface is supplied as standard with each Powerware 9335. You can use this port to link the UPS to the features described in Chapter 10, "Communications" and Chapter 11, "Options."

6.3.2 Battery Management

A two-stage charging system ensures that the initial recharge is done in an optimal time, with current limited, constant current, DC applied to the batteries. When terminal voltage reaches a certain level, the charger switches to constant voltage.

6.3.3 Installation Features

Power wiring can be routed through the rear and bottom of the UPS cabinet with connections made to easily accessible terminal blocks at the bottom front of the cabinet. External monitoring and communication control wiring must be installed in accordance with approved wiring methods. Communication wiring can be routed through the top of each cabinet.

Communication option cards are quickly installed in the slot behind the front door panel. X-slot cards are hot pluggable.

6.4 Options and Accessories

Contact your sales representative for information about any of these available options:

6.4.1 Remote EMERGENCY POWER OFF

A REMOTE EMERGENCY POWER OFF pushbutton is an option to provide for situations where you must instantaneously control the UPS output. The operation of the REMOTE EMERGENCY POWER OFF pushbutton is described in detail in Chapter 8, “UPS Operating Instructions.”

6.4.2 Battery Cabinets

A complete UPS system requires one or more battery cabinets to provide the necessary DC backup power. Battery cabinets are designed to match with the UPS cabinet, although they do not directly bolt together.

6.4.3 Communications

See Chapter 10, “Communications”.

6.4.4 Other Options

Refer to Chapter 11 of this manual to review other options available for the Powerware 9335 and their use.

6.5 Safety Considerations

The UPS enclosure is designed for industrial or computer room applications and contains safety shields. However, the system is sophisticated and should be handled with appropriate care, following these guidelines.

- **Keep surroundings clean and free from excess moisture.**
- **Do not operate the system close to gas or electric heat sources.**
- **The system is not intended for outdoor use.**
- **The system operating environment should be maintained within the parameters stated in this manual.**
- **Keep the system doors closed to ensure proper cooling airflow and to protect personnel from dangerous voltages inside the unit.**
- **The system contains its own power source. Lethal voltages are present even when the system is disconnected from utility power.**

<p>WARNING: Only AUTHORIZED SERVICE PERSONNEL should perform service or maintenance on the UPS.</p>

If service or routine maintenance is required:

- **Ensure all power is disconnected before performing installation or service.**
- **Ensure the area around the UPS is clean and uncluttered.**
- **Battery cabinet maintenance or battery replacement should be performed only by authorized service personnel.**
- **Observe all DANGER, CAUTION, and WARNING notices affixed to the inside and outside of the equipment.**
- **Always conform to the more detailed safety precautions described in “Important Safety Instructions” section of Chapter 12, “Maintaining the UPS System”.**

6.6 Symbols, Controls, and Indicators

These symbols may appear on your UPS system or on labels inside the UPS. Most international safety agents accept them. Everyone in your organization who works with your system should understand the meaning of these symbols:



PROTECTIVE GROUNDING TERMINAL
A terminal which must be connected to earth ground prior to making any other connection to the equipment.



A terminal to which or from which a direct current or voltage may be applied or supplied.



This symbol indicates the word “phase”.



ON
The principal power switch is in the “ON” position.



OFF
The principal power switch is in the “OFF” position.



CAUTION: REFER TO MANUAL
Stop and refer to the Operator’s Manual for more information



DANGER: RISK OF ELECTRIC SHOCK
There is a risk of electric shock present, and you should observe associated warnings. The UPS contains high voltages.

Using the Control Panel

7.1 Description

This chapter describes the UPS Control Panel, including controls and indicators, and how to monitor UPS operation. The control panel is located on the front of the UPS (see Figure 7–1).

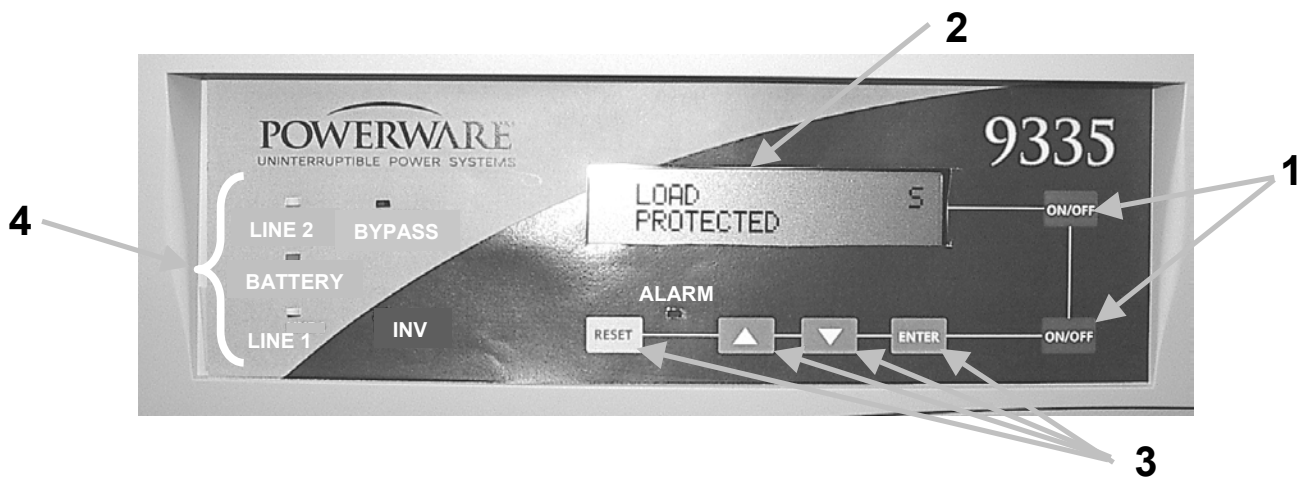

Figure 7–1. UPS Control Panel

The Control Panel contains:

- 1) the main power ON/OFF switches
- 2) a flat Liquid Crystal Display (LCD) screen
- 3) a horizontal row of navigation pushbuttons
- 4) an array of multi-color LED status indicators

Refer to Chapter 8, “UPS Operating Instructions” for use of the operational controls.

7.2 Using the Control Panel

The Control Panel provides an operator interface with the UPS system. Figure 7–2 identifies the display and pushbutton areas discussed in the following sections as well as LED indicators that provide a visual display of system operating status.

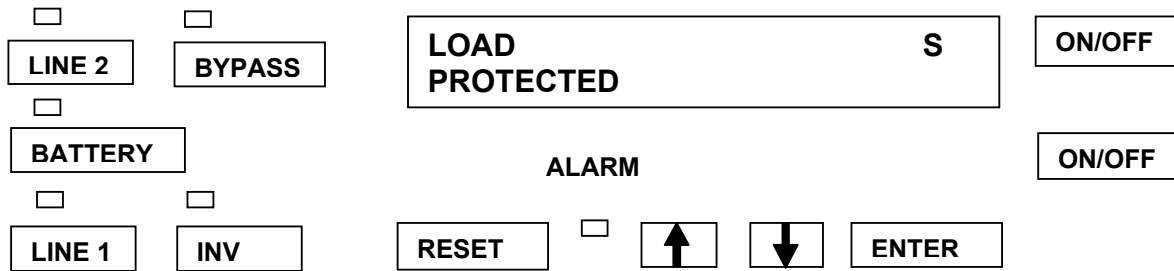

Figure 7–2. LCD Screen and Pushbuttons

7.2.1 Power Management Display

The 2 x 20 character LCD Screen simplifies the communication with the UPS and provides the necessary monitoring information about the UPS. The menu driven LCD Screen enables access to the

- 1) EVENT REGISTER
- 2) Measurements of input and output voltage, current, frequency, power and battery runtime
- 3) System commands for start-up and shut-down of the UPS and load transfer from INVERTER to BYPASS and return
- 4) DIAGNOSIS (SERVICE MODE)
- 5) Adjustments and testing information

7.2.2 LED Indicators

The LED indicators display the general status of the UPS. Indicators show the power flow status and in the event of power failure or load transfer from inverter to bypass or vice-versa, the corresponding LED indicators will change color from green (normal) to red (warning). The LINE 1 and LINE 2 LEDs indicate the availability of the input power supply. The INVERTER and BYPASS LEDs, if green, indicate which of the two power paths is supplying power to the critical load. When the battery is supplying the load, due to supply failure, the BATTERY LED will be flashing. The ALARM LED is a visual indication of any internal or external alarm conditions. At the same time, an audible alarm will be activated.

INDICATOR	INDICATOR STATUS	MEANING
ALARM	OFF RED + BUZZER RED	No alarm condition Alarm condition Alarm condition persists
LINE 1	GREEN RED	Utility supply to rectifier available Utility supply to rectifier not available
LINE 2	GREEN RED	Bypass supply available Bypass supply not available or not OK
BYPASS	GREEN OFF	Load on bypass (Bypass or Eco-mode) Bypass not operating (or switched off)
INV	GREEN RED OFF	Load on inverter Inverter fault or load not transferable to inverter Inverter not operating (switched off)
BATTERY	GREEN RED Flashing GREEN Flashing GREEN	Battery OK Battery fault or battery is discharged Battery discharging or battery fuse open Load OFF command issued

7.2.3 Pushbutton Functions

The pushbuttons allow the user to operate the UPS to perform settings and adjustments, to start-up and shutdown the UPS, and to monitor on the LCD display the voltages, currents, frequencies and other variables of system operation.

KEYS	FUNCTION
ON/OFF	Turn-on UPS system (press both pushbuttons simultaneously) or
ON/OFF	Shutdown the UPS (press both pushbuttons simultaneously)
UP (↑)	Move upwards through the menu
DOWN (↓)	Move downwards through the menu
RESET	Move to the top of the menu. Cancel the audible alarm. If the alarm condition was only transient, the LED indicator (ALARM) will also extinguish, otherwise it will remain on (RED)
ENTER	Confirms a chosen menu item

7.2.4 ON/OFF Startup and Shutdown Pushbuttons

By pressing simultaneously both ON/OFF pushbuttons on the Control Panel, the UPS can be switched on (if currently OFF) or shutdown immediately (if currently ON). Requiring both to be simultaneously depressed prevents accidental operation of the UPS. The two main ON/OFF pushbuttons are also used as a security ON/OFF switch, making it possible to quickly disconnect the load from the UPS in emergency situations. Upon startup from initial install or power off disconnect, the UPS starts in NORMAL (inverter) mode. In subsequent startups, the system will return to the mode previously used before shutdown, except that ECO mode will require operator intervention to activate.

CAUTION:
ACTIVATION OF THE ON/OFF PUSHBUTTONS WHEN THE UPS IS NOT IN MAINTENANCE BYPASS MODE WILL INTERRUPT THE POWER SUPPLY TO THE CRITICAL LOAD.

If, for security or emergency reasons, it is necessary to immediately disconnect the load from the UPS, press the two red ON/OFF pushbuttons simultaneously. In this case, make sure that the maintenance bypass switch (IA1) is in the “O” position (Normal=Off).

7.3 Description of the LCD Screen

7.3.1 Status Screens

DESCRIPTION

Load is protected by UPS power. It is supplied by the inverter (normal operation)

Load is not protected by UPS power. It is supplied by utility power. (load on bypass)

Load supply is completely interrupted. UPS has been switched off by “ON/OFF” buttons

LCD DISPLAY

LOAD PROTECTED	S
LOAD NOT PROTECTED	S
LOAD OFF SUPPLY FAILURE	S

NOTE: On the right hand side of the LCD display there should be a character “S” indicating the Single Module is operational.

7.3.2 LCD Display Structure and Navigation

The menu structure is shown in Figure 7–3, below. Navigation through the menu is accomplished by using the “ENTER” pushbutton to go to the menu level, or to activate an action, then using the “UP” or “DOWN” arrows to select a specific function within each menu category. The “RESET” pushbutton will immediately return to the highest screen.

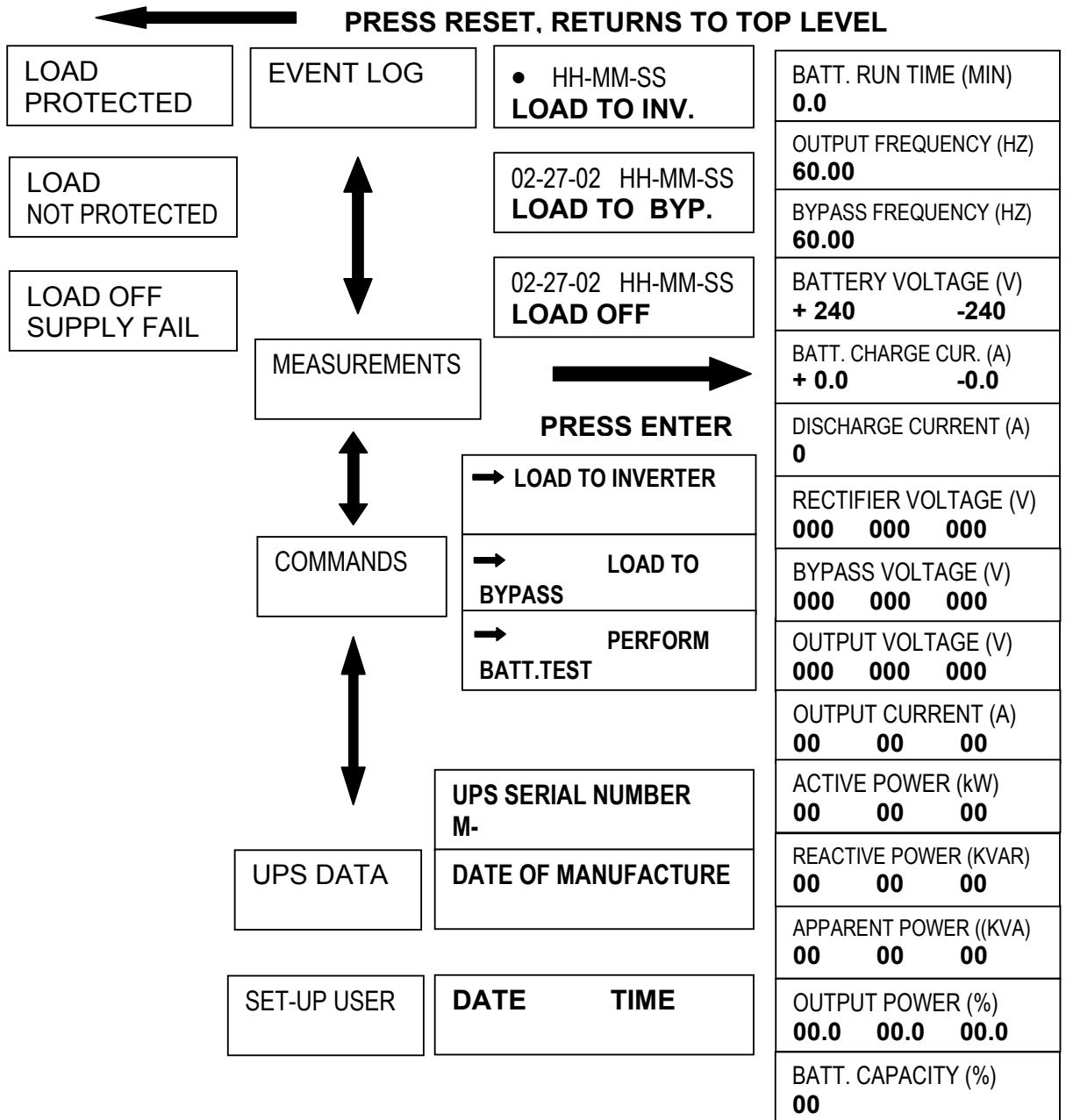

Figure 7–3. LCD Screen Navigation Chart

7.3.3 Main Menu Screen

DESCRIPTION

- Logging Control. A log of the last 64 events is stored in the Power Management Display.
- Menu Measurements allow monitoring voltages, power, frequencies, current, battery run time, and other information.
- Command Menu enables performance of “Load to Inverter”, “Load to Bypass”, and battery test functions.
- UPS Data Menu shows UPS serial number, date of manufacture, current time & date.
- Set-Up Menu allows user to set Date/Time, automatic battery test and gen-set mode
- Set-Up Menu for service allows trained service personnel to troubleshoot and adjust system parameters.

LCD DISPLAY

→	EVENT LOG
→	MEASUREMENTS
→	COMMANDS
→	UPS DATA
→	SET-UP USER
→	SET-UP SERVICE

7.3.4 Event Log Screen

DESCRIPTION

- Logging Control (sample screen)
- A log of the last 64 events is stored and presented under the Event Log.
- All events and alarms are displayed with their date and time of occurrence.

LCD DISPLAY

02-27-02	17-03-30
LOAD TO INV.	
02-27-02	17-03-30
LOAD TO BYP.	
02-27-02	17-03-30
LOAD OFF	

7.3.5 Measurements Screen

DESCRIPTION

- Battery Runtime remaining (in minutes)
- UPS Output Frequency
- Bypass Frequency

LCD DISPLAY

BATT. RUN TIME (MIN)
0.0
OUTPUT FREQUENCY (HZ)
60.00
BYPASS FREQUENCY (HZ)
60.00

- Battery Voltage
- Battery Charger Current
- Discharge Current
- Rectifier Voltage (all three phases)
- Bypass Voltage (all three phases)
- Output Voltage (all three phases)
- Output Current (all three phases)
- Active Output Power (all three phases)
- Reactive Output Power (all three phases)
- Apparent Output Power (all three phases)
- Output Power (% , all three phases)
- Battery Capacity remaining

BATTERY VOLTAGE (V)		
+240		-240
BATT. CHARGE CUR. (A)		
+ 0.0		- 0.0
DISCHARGE CURRENT (A)		
+ 0.0		- 0.0
RECTIFIER VOLTAGE (V)		
0	0	0
BYPASS VOLTAGE (V)		
0	0	0
OUTPUT VOLTAGE (V)		
0	0	0
OUTPUT CURRENT (A)		
0	0	0
ACTIVE POWER (kW)		
0	0	0
REACTIVE POWER (kVAR)		
0	0	0
APPARENT POWER (KVA)		
0	0	0
OUTPUT POWER (%)		
0%	0%	0%
BATT. CAPACITY (%)		
0%		

7.3.6 Commands Screen

DESCRIPTION

- Transfer Load to Inverter
- Transfer Load to Bypass
- Battery Test

LCD DISPLAY

➔	LOAD TO INVERTER
➔	LOAD TO BYPASS
➔	PERFORM BATT. TEST

7.3.7 UPS Data

DESCRIPTION

- Information displayed is installed at the time of manufacture.
- Manufacturing Date
- EPROM Version
- Actual Date and Time (set by user under user set-up menu).

LCD DISPLAY

UPS SERIAL NUMBER M-	
DATE OF MANUFACTURE DD-MM-YY	
EPROM VERSION V-000	
DATE DD-MM-YY	TIME HH-MM-SS

7.3.8 Set-Up User

DESCRIPTION

- Set-up Date and Time (Press ENTER to access)
- Set-up Battery test (Press ENTER to access)
- Set-up operation with Gen-Set (Press ENTER to access)
- Command to prevent battery charger operation when on generator operation.
- Command to prevent use of static bypass when on generator operation.

LCD DISPLAY

→ SET-UP DATE/TIME	
DD-MM-YY HH-MM-SS	
→ SET-UP BATT. TEST	
DAY OF MONTH	
HOUR OF DAY	
REPETITIVE (Y/N)	
→ SET-UP GEN-SET OPER.	
BATTERY CHARGE LOCK (Y/N)	
BYPASS LOCK/UNLOCK	

7.3.9 Set-Up Service

DESCRIPTION

- This menu is reserved for authorized service engineers. It is not to be accessed by End-Users.
- Type in password.

LCD DISPLAY

➔	SET-UP SERVICE
➔	PASSWORD

NOTE: *Apart from the adjustment of voltages, frequencies, currents, power and battery run time in the SET-UP Service menu, it is also possible to set and check the following parameters:*

- UPS Rated Power
- Module configuration S or future alternate module configurations
- Single (standard) or Dual Input feed
- F-converter, 50/60Hz or 60/50Hz
- Sync window (2-4%)

7.4 Operating Modes

7.4.1 “ON LINE” Mode (INVERTER MODE)

The ON-LINE Mode is the UPS Operating Mode in which the load is supplied through the RECTIFIER and INVERTER. LED indicators are illuminated when shown shaded:

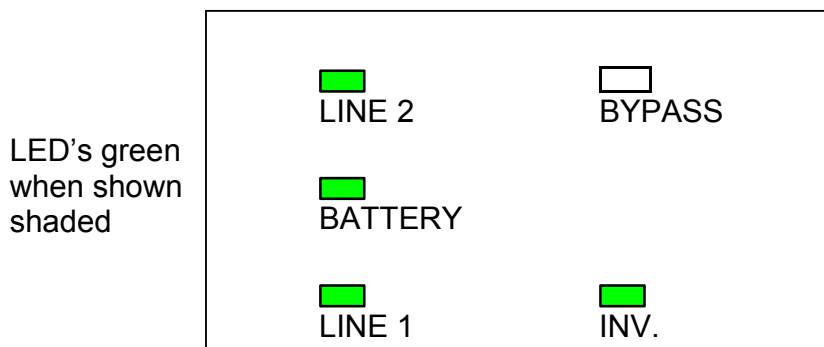

Using the control panel (see Figure 7–2) the UPS can easily be transferred to the ON-LINE mode. The ON-LINE mode provides the highest degree of protection, especially in the event of a supply disturbance or failure. This operating mode is always recommended if the critical loads (computer systems) will not tolerate any interruption of the supply, even for a very short time. In the unlikely event of an inverter fault or overload condition, the UPS will transfer the load automatically and without interruption to the static bypass-utility supply.

7.4.2 “OFF LINE” Mode (BYPASS or ECONOMY MODE)

In the OFF-LINE mode, the load is supplied from the utility supply through the bypass. Using the control panel (see Figure 7–2), the UPS may be easily transferred to “Bypass Mode”.

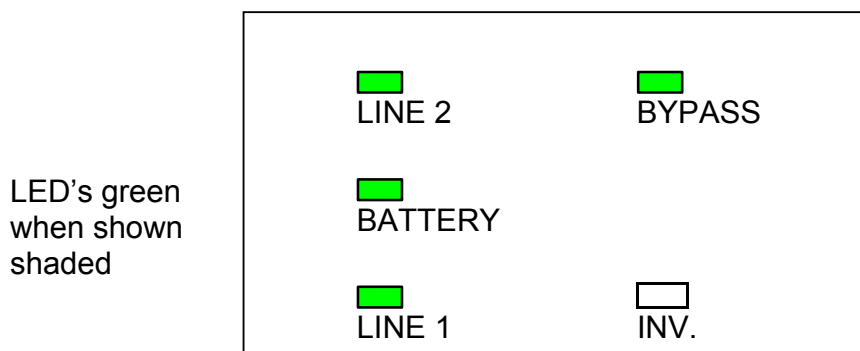

When the UPS is operating in “Bypass Mode”, the efficiency of the system is higher. In the event of a utility supply failure the load will automatically be transferred from utility to

inverter within 5 milliseconds. When utility power returns, the UPS will startup in NORMAL (inverter) mode. Operator intervention is required to reset to ECO mode. The battery charger remains active in the “Bypass-Mode”. The “Bypass-Mode” is recommended only if the loads can tolerate power interruptions of up to 5 ms, the transfer time from Bypass Mode to ON-LINE Mode.

CAUTION:

In order to provide the load with maximum protection, it is always recommended that the load be supplied by the inverter (ON-LINE Mode).

7.4.3 “MAINTENANCE BYPASS” Mode

The Maintenance Bypass Mode is performed by means of the IA1 BYPASS SWITCH on the front of the UPS. When the switch is in the “O” (OFF) position, the Bypass Switch is OPEN. This is the normal operating condition, where the load is supplied by the inverter, or via the static bypass. When the switch is in the “I” (ON) position, the Bypass Switch is CLOSED, causing load power to be supplied directly from the utility source.

LED's green when shown shaded, unless noted

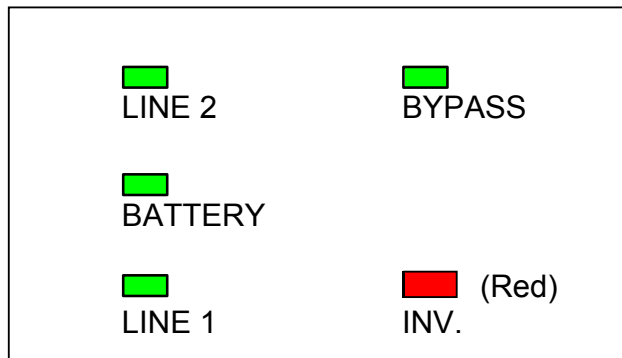

CAUTION:

Before transferring the load to Maintenance Bypass using the IA1 switch, always make sure that the UPS cabinet is in the “Bypass-Mode”. Failure to observe this procedure can cause equipment damage.

CAUTION:

When the UPS is operated in the Maintenance Bypass mode through the Bypass Switch IA1, the load will not be protected in the event of a utility supply failure. It is therefore strongly recommended that the user switch back to ON-LINE (INVERTER ON) or BYPASS (OFF-LINE MODE) as soon as possible.

7.4.4 Parallel Isolator (IA2)

The UPS unit is provided with an output isolator switch (IA2) which, when opened, isolates the corresponding unit from the LOAD. Once IA2 is open, there is no power coming from the inverter. This switch should always be in the "I" (ON) position, except for servicing the UPS when in the maintenance bypass mode. Rotating this switch to the "O" (OFF) position while the inverter is supplying power to the load will dump the critical load. This switch is also provided for future expansion requirements.

WARNING:

Rotating the output isolator switch (IA2) to the "O" (OFF) position when the maintenance bypass switch (IA1) is in the "O" (OFF) position will interrupt power to the critical load.

UPS Operating Instructions

8.1 Operation

The following procedures provide instruction for operating the UPS system. Refer to Chapters 6 and 7 of this manual for a description of the UPS controls and monitor panel functions.

NOTE: Before starting the UPS, ensure all installation tasks are complete and authorized service personnel have performed a preliminary startup. The preliminary startup verifies all electrical interconnections to ensure the installation was successful and the UPS operates properly.

8.2 Start-Up Procedure for the UPS

CAUTION:

All the operations in this section must be performed by authorized service technicians or by qualified internal personnel.

To start the UPS system for normal operation, perform the following procedure:

1. Ensure the UPS switches and external customer circuit breakers are set as follows:

UPS Utility Supply Breaker (customer supplied)	“O” (OPEN)
UPS Bypass Input Breaker (dual source, customer supplied)	“O” (OPEN)
UPS Battery Cabinet Breaker (customer supplied)	“O” (OPEN)
UPS Maintenance Bypass Switch (IA1)	“O” (OFF)
UPS Parallel Isolator Switch (IA2)	“O” (OFF)
Verify Position of DIP Switches SW 2–9 are as in Fig. 6-1.	As shown

2. Close the UPS utility supply breaker. (Screen event “MAIN RECTIFIER FAULT” appears)
3. If system is dual source, close the UPS Bypass input circuit breaker
4. Observe LED Line 1 indicator turns green and battery indicator LED flashes green. (Screen event “LOAD OFF SUPPLY FAILURE” appears)
5. Press both ON/OFF pushbuttons on the control panel simultaneously to turn on the UPS. “LOAD NOT PROTECTED” will appear on the LCD screen and LED indicators will display as follows:

LED Indicator	Color
LINE 1	Green
LINE 2	Green
BYPASS	Green
INVERTER	OFF
BATTERY	Flashing Green

6. If necessary, perform Command: LOAD TO INVERTER (see sections 7.3.2 and 7.3.6) On LCD Display, “LOAD PROTECTED” will appear and the LED-indicators will display as follows:

LED Indicator	Color
LINE 1	Green
LINE 2	Green
BYPASS	OFF
INVERTER	Green
BATTERY	Flashing Green

7. Close the external battery cabinet circuit breaker.
8. Scroll through the measurements menu and verify that battery polarity and voltage are proper and within prescribed limits (see sections 7.3.2 and 7.3.5). For the 80 kVA model, the voltages will be about +260 and –260. For the 120 kVA model, the voltages will about +312 and –312 volts.
9. Close Parallel Isolator Switch (IA2) to position “I” (ON). UPS power is now present on the output terminal block and “LOAD PROTECTED” will appear on the LCD display. After 45-120 seconds, the battery LED will change from Flashing Green to Solid Green. This state change will take up to one minute.

On initial start-up follow steps 9-14. On re-start stop at 9.

10. Perform load transfer to Maintenance Bypass

- Use Menu COMMANDS on UPS control panel and choose “LOAD TO BYPASS” (see sections 7.3.2 and 7.3.6) to transfer the load to the bypass source.
- Close Maintenance Bypass Switch (IA1) to position “I” (ON). The LCD display will show “MANUAL BYP. CLOSED” and the LED indicators will appear as follows:

LED Indicator	Color
LINE 1	Green
LINE 2	Green
BYPASS	Green
INVERTER	Red
BATTERY	Green

11. Connect load to the UPS output

- Close external output circuit breakers in the load distribution panel
- Verify on the LCD Display and LED indicators that the load is on Bypass.

12. Rotate the Maintenance Bypass Switch IA1 to the "O" (OFF) position. On the LCD Display, "MANUAL BYP. OPEN" will appear followed by "LOAD NOT PROTECTED".
13. Using the Measurements menu (see sections 7.3.2 and 7.3.5) verify proper values for output powers, voltages, currents and frequencies.
14. Perform Load transfer to Inverter
 - Go to COMMANDS menu on UPS cabinet control panel and choose command "LOAD TO INVERTER" to transfer the load to inverter output. (see sections 7.3.2 and 7.3.6)
 - On LCD Display, "LOAD PROTECTED" will appear.
15. Repeat step 13 above to verify that all voltages, currents, power and frequency are correct.
16. Once the above procedure is performed at initial start-up, subsequent start-ups may be performed using only step 14, as long as other conditions are unchanged.

THE POWERWARE 9335 UPS NOW PROTECTS THE LOAD.

8.3 Complete Shutdown Procedure for the UPS

The Powerware 9335 may be shut down completely if the load does not need input power for an extended period of time.

The UPS system may be switched to Maintenance Bypass Mode for service or maintenance purposes, or transferred to the ECO-Mode if the load does not need the highest degree of protection and efficiency is to be maximized.

The load may be disconnected by means of the two ON/OFF (LOAD-OFF) pushbuttons for security or operational reasons.

CAUTION:

If the Powerware 9335 will remain deactivated for an extended period of time, provision must be made for periodic recharge of the system batteries.

CAUTION:

All the operations in this section must be performed by authorized service technicians or by qualified internal personnel.

CAUTION:

Activation of both ON/OFF buttons simultaneously during normal operation will switch off the UPS output and no longer supply power to the load.

1. Verify that the loads are shut down and that there is no need for power supply to the load.

2. If the loads are all disconnected, press simultaneously the two ON/OFF buttons on the UPS control panel. On the LCD Display, "LOAD OFF, SUPPLY FAILURE" will appear and the LED-indicator will indicate as shown below:

LED Indicator	Color
LINE 1	Green
LINE 2	OFF
BYPASS	OFF
INVERTER	OFF
BATTERY	Flashing Green

3. Rotate the Parallel Isolator Switch (IA2) to the "O" (OFF) position.
4. Open battery cabinet breakers in external battery cabinets or racks.
5. Open the input utility supply circuit breakers, if used.

THE POWERWARE 9335 IS NOW VOLTAGE FREE.

8.4 Load Transfer to Maintenance Bypass

If it is necessary to perform service or maintenance on the UPS, it is possible to transfer the UPS to MAINTENANCE BYPASS.

CAUTION:
BEFORE YOU ROTATE THE MAINTENANCE BYPASS SWITCH TO POSITION "I" (ON), MAKE SURE THAT THE LOAD HAS BEEN TRANSFERRED TO THE BYPASS MODE. EVEN THOUGH THE UNIT IS IN BYPASS MODE, LETHAL VOLTAGE IS STILL PRESENT WITHIN THE UPS CABINET.

CAUTION:
ALL THE OPERATIONS IN THIS SECTION MUST BE PERFORMED BY AUTHORIZED ELECTRICIANS OR BY QUALIFIED INTERNAL PERSONNEL.

Status of the UPS-System before starting the Transfer Procedure to Maintenance Bypass

The load is protected by the Powerware 9335 UPS system in normal operation (the UPS is operating on inverter).

- 1) Load transfer to Maintenance Bypass
 - Go to Menu COMMANDS and choose command "LOAD TO BYPASS" and transfer the load to utility supply on control panel of the UPS cabinet. On the LCD Display: "LOAD NOT PROTECTED" will appear.

- Rotate the Maintenance Bypass Switch IA1 to “I” (ON)
On LCD Display: “MANUAL BYP CLOSED” will appear and the LED indicators will indicate as shown below:

LED Indicator	Color
LINE 1	Green
LINE 2	Green
BYPASS	Green
INVERTER	Red
BATTERY	Green

- 2) Simultaneously press both ON/OFF pushbuttons on the UPS cabinet control panel.
- On the LCD Display: “LOAD OFF, SUPPLY FAILURE” will appear and the LED indicators will indicate as shown below:

LED Indicator	Color
LINE 1	Green
LINE 2	OFF
BYPASS	OFF
INVERTER	OFF
BATTERY	Flashing Green

- 3) Rotate the Parallel Isolator Switch IA2 to “O” (OFF).
- 4) Open battery breakers in the external battery cabinet or racks

THE LOAD IS NOW SUPPLIED BY THE UTILITY MAINS AND IS NOT PROTECTED.

This page left intentionally blank.

Responding to System Events

9.1 Alarms

In the event of an alarm condition, the red LED-Indicator “Alarm” and the audible alarm will turn on.

In this case proceed as follows:

- A. Silence the audible alarm by pressing the "Reset" button.
- B. Identify the cause of the alarm condition by means of the EVENT LOG in the MAIN menu.
- C. In case of alarm conditions, please contact the Global Service Center.
- D. Fault identification and suggested corrective action is given on the following pages.

9.2 Menu, Commands, Event Log, and Measurements

In Chapter 4 there is a detailed description of the Menu, Commands, Event Log and Measurements that can be operated and displayed on the LCD. The List of Alarms and Messages are shown in Section 9.3.

9.3 *Fault Identification and Correction*

The major alarm conditions that will be encountered are shown in the following table:

Alarm Condition	Meaning	Suggested Solution
UPS FAULT	There is a fault in the UPS and therefore normal operation cannot be guaranteed.	Call the authorized service center for assistance
MAINS FAILURE	The utility power supply is outside its prescribed tolerance.	The input power to UPS is too low or missing. If site power appears to be OK, check the input circuit breakers etc. supplying the UPS
OVERCURRENT OR SHORT CIRCUIT	There is a short circuit at the output of UPS. (on load side)	Check all output connections and repair as required.
OVERLOAD	Load exceeds the UPS rated power.	Identify which piece of equipment is causing the overload and remove it from the UPS.
OVERTEMPERATURE	UPS temperature has exceeded the allowed value.	Check that the ambient temperature of the UPS is less than 30° C. If the ambient temperature is normal call the authorized service center for assistance.
BATTERY CHARGER OFF	The attached battery and the battery charger set-up do not correspond or battery charger fault.	Call the authorized service center for assistance.
INVERTER FAULT	Inverter is faulty.	Call the authorized service center for assistance.
NON-SYNCH	The inverter and utility power are not synchronized.	The frequency of the input voltage to the UPS is outside operational limits and the UPS static bypass has been temporarily disabled.
BATTERY LOW	The battery is nearly discharged.	Shutdown load connected to UPS before the UPS switches itself off to protect its batteries
MANUAL SWITCH OFF	Maintenance Bypass closed. Load supplied by utility power.	This alarm is only displayed if the UPS is on Maintenance Bypass

10.1 X – Slot Communication Modules

This section describes the several types of X–Slot cards, which can be used with the Powerware 9335. X-Slot cards allow the UPS to communicate to a variety of environments and with different types of devices. The Powerware 9335 is compatible with any X–Slot card, including, but not limited to:

- ConnectUPS™ SNMP/WEB Card – provides 10Base-T Ethernet connectivity for web-based remote monitoring in addition to SNMP capabilities.
- ConnectUPS M SNMP Card – provides 10Base-T Ethernet connectivity for SNMP-based remote monitoring.
- Single-Port Card – provides one serial communication port.
- USB Card – provides a USB connection to your Windows PC.
- Multi-Server Card – provides additional serial communication ports that can communicate with additional computers.
- Modbus Card – provides RS-485 and RS-232 Modbus RTU connectivity for integration with building management systems.
- Relay Card – provides dry relay contacts for AS/400 signal compatibility.

The Powerware 9335 is factory installed with a Single-Port Serial Card.

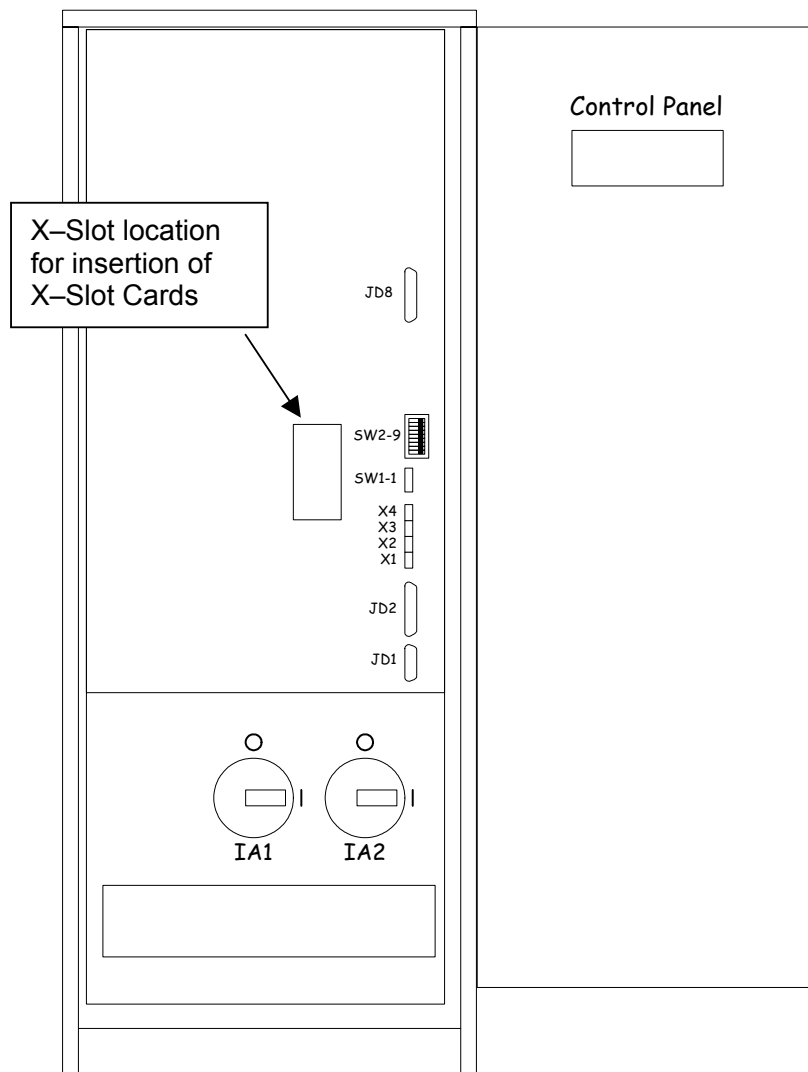

Figure 10–1. X-Slot Location on Front of Powerware 9335 UPS Cabinet

10.2 Single-Port Serial Card

To establish communications between the UPS and a computer, connect your computer to the UPS communication port using the supplied communication cable.

When the communication cable is installed, power management software installed on your computer can exchange data with the UPS. Powerware supplies monitoring software with each UPS. See instructions packaged with the software for installation and operation. The software polls the UPS for detailed information on the status of the

power environment. If a power emergency occurs, the software initiates the saving of all data and an orderly shutdown of the connected critical load.

The cable pins are identified in Figure 10–2 and the pin functions are described in Table 10–1.

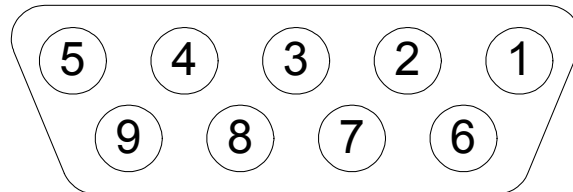

Figure 10–2. The Communication Port on the Single Port Serial Card

Pin Number	Function	Input or Output
1	Low Battery Open Collector signal – pulls to common when the UPS reaches low battery level	Output
2	RS-232 Transmit Data	Output
3	RS-232 Receive Data	Input
4	Plug and Play sense	Input
5	Signal Common (tied to chassis)	–
6	Tied internally to pin 4	Output
7	No Connection	–
8	AC Fail Open Collector signal – pulls to common during a power failure	Output
9	DC Supply Voltage (+8 to 24 volts DC power)	Output

Table 10–1. Communication Port Pin Assignments

This page left intentionally blank.

11.1 Generator ON Facility

The generator ON facility must use a normally open contact that closes to indicate that a generator is running and supplying input power to the UPS. When used, this facility disables the UPS static bypass and prevents the UPS from transferring the load into the generator power supply. The user may also elect prevention of battery charging while on generator input. Both or either of these features may be selected via the control panel. (See section 7.3.8, Set Up)

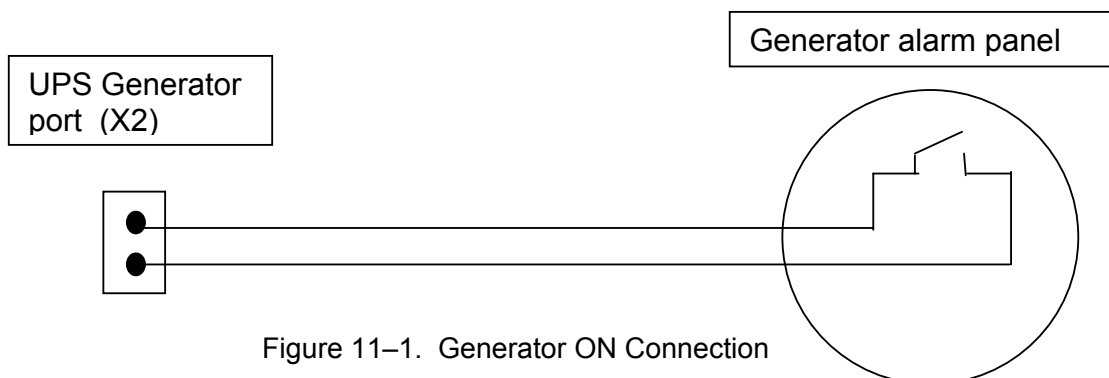

Figure 11–1. Generator ON Connection

This page left intentionally blank

Maintaining the UPS System

12

12.1 General

The components inside the UPS cabinet are secured to a sturdy metal frame. All repairable parts and assemblies are located for easy removal, and very little disassembly. This design allows authorized service personnel to perform routine maintenance and servicing quickly.

You must schedule periodic performance checks of your UPS system to keep it running properly. Regular routine checks of operation and system parameters will enable your system to function efficiently for many trouble-free years.

12.2 Important Safety Instructions

Remember that your UPS system is designed to supply **power EVEN WHEN DISCONNECTED FROM THE UTILITY POWER**. The UPS cabinet interiors are unsafe until the DC power source is disconnected and all capacitors are discharged. After disconnecting the utility power and the DC power, authorized service personnel should wait at least 5 minutes for capacitor bleed off before attempting internal access to the UPS cabinet.

WARNING:
Servicing and maintenance should be performed only by qualified service personnel.

DANGER:
LETHAL VOLTAGE PRESENT: This unit should not be operated with the cabinet doors open or protective panels removed. Do not make any assumptions about the electrical state of any cabinet in the UPS system.

Since each battery string is an energy source in itself, opening the Battery Circuit Breaker does not de-energize the voltage within the battery string. **DO NOT ATTEMPT TO ACCESS ANY INTERNAL AREA OF THE BATTERY STRING YOURSELF. VOLTAGES ARE ALWAYS PRESENT IN THE BATTERY STRING.** If you suspect that a battery string needs service, you should contact your local field service office.

12.3 Performing Preventive Maintenance

The UPS system requires very little preventive maintenance. However, the system should be inspected periodically to verify that the units are operating normally and that the batteries are in good condition.

Perform the following checks DAILY:

1. Check the area surrounding the UPS system. Ensure the area is not cluttered, allowing free access to the unit.
2. Ensure the air intakes (vents on the bottom) and exhaust opening (on the top of the cabinet) are not blocked.
3. Ensure the operating environment is within the parameters specified in Chapter 13, "Product Specifications."
4. Ensure the UPS is in Normal mode. (Proper LED indicators are illuminated and the LCD display shows "LOAD PROTECTED"). If the alarm LED is illuminated or the Normal status LEDs are not illuminated, contact Customer Service.

Perform the following check MONTHLY:

1. Review the Event Log for any operational issues that need attention.

ANNUAL maintenance:

Annual preventive maintenance should be performed only by authorized service personnel familiar with maintenance and servicing of the UPS system. Contact your nearest field service office for more information about service offerings.

BATTERY Test:

The battery test takes approximately 3 minutes and should be performed only if:

- There are no alarm conditions
- The battery is fully charged
- Utility supply is present and normal

The battery testing can be carried out independently of the operation mode (OFF-LINE or ON-LINE) and whether or not the load is connected. The battery test procedure can be performed from the UPS front panel. See Chapter 7, "Using the Control Panel".

BATTERY Maintenance:

Contact your nearest field service office for battery maintenance. Only authorized service personnel should perform Battery replacement and maintenance.

Product Specifications



13.1 System Information

The UPS systems are housed in freestanding cabinets with safety shields behind the front panels. The UPS systems are available in 50 or 60 Hz configurations with either 80 or 120 kVA output ratings. The following sections detail the input output, environmental and battery specifications for each model.

13.2 UPS System Input

Operating Input Voltage (Nominal +15 / -20%)	480 VAC for operation from 384 VAC to 552 VAC (50/60 Hz)
Operating Input Frequency Range	45 – 65 Hz (continuous duty)
Maximum Input Current	80 kVA Model 158 amperes 120 kVA Model 225 amperes
Input Current Harmonic Content	Less than 9% input THD at full load
Power Factor	Minimum 0.98
Battery Voltage	80 kVA model ±240 volts nominal 120 kVA model ±288 volts nominal (center point connected to neutral)
Maximum Battery Current	315 amperes (120 kVA): 252 amperes (80 kVA)
Maximum Battery Charge Current	Up to 32 amperes

13.3 UPS System Output

DC Ripple	less than 1% voltage ripple
UPS Output Capacity	100% rated current at 0.8 power factor
Output Voltage Regulation	±1.5% (10–100% load)
Output Voltage Harmonic Content	Less than 1%
Output Voltage Balance	Each phase may be loaded to 100% independently with voltage regulation within stated tolerance.
Output Voltage Phase Displacement	120 degrees between phases ±0.01 degree
Output Transients	< ±4% for 0 to 100% or 100% to 0% load change
Frequency Regulation	±0.1% free running
Synchronous to Bypass	No-break transfer
Frequency Slew Rate	1 Hz per second maximum
Overload Capacity	101% to 125% for 10 minutes (25C) 126% to 150% for 30 seconds
Maximum Output Capability	200% RMS for 10 cycles without bypass

13.4 Environmental Specifications

Dimensions (W x H x D) mm (in.)	700 (27.6) x 1800 (70.9) x 750 (29.6)
Weight Kg (lb.) 80 kVA Model	333 (733)
Weight Kg (lb.) 120 kVA Model	340 (748)
Operating temperature	0 to 40°C (32 to 104°F)
Operating Altitude	1500 meters (5000 feet) with no derating
Storage Temperature	0 to 50°C (32 to 122°F)
Relative Humidity	Maximum 95%, non-condensing
Audible Noise with 100%/75% Load	65/63 dBA (80 kVA) 70/65 dBA (120 kVA)
EMI Suppression	IEC 62040-3 & FCC A
Electrostatic Discharge (ESD) Immunity	IEC 801-2
Applicable Standards	UL 1778 (Computer Room Suitable)

Appendix A – Customer Information

The information in this appendix will help you plan for and install your UPS system. This appendix contains the following:

Table A	Input/Output Ratings and external wiring 9335 – 80
Table B	Input/Output Ratings and external wiring 9335 – 120
Table C	UPS Power Cable Terminations 9335 – 80 & –120
Table D	Power Cable Conduit Requirements 9335 – 80 & –120
Table E	Maximum Input Circuit Breaker Ratings
Table F	Maximum Output Circuit Breaker Ratings
Table G	Customer Interface Inputs and Outputs
Table H	Customer interface to JD2
Table I	Customer connections to JD1
Table J	Equipment Weight
Table K	System Clearances
Table L	Air Conditioning or Ventilation Requirements
Figure A–1	Front View of Powerware 9335 showing customer connections
Figure A–2	Label of Powerware 9335
Figure A–3	One-line diagram of Powerware 9335
Figure A–4	Power terminal connections for Powerware 9335
Figure A–5, –6	UPS System Information
Figure A–7, –8	UPS Cabinet Dimensions

**Table A. INPUT/OUTPUT Ratings & External Wiring Requirements for
Powerware 9335 – 80 kVA**

Ratings		Units	Rating 50/60 Hz
Basic unit ratings at 0.8 lagging PF load		kVA W	80
		INPUT/ OUTPUT VOLTAGE	480
AC INPUT A	AC Input to UPS Rectifier (0.95 min. PF) 3 phase, 1 neutral, 1 ground Minimum conductor size *Max. amps include full load current plus battery recharge current	Amps*	105
		AWG or kcmil (ea)	1/0
AC INPUT B	AC Input to UPS Bypass - Full Load Current 3 phase, 1 neutral, 1 ground	Amps*	97
	Minimum conductor size	AWG or kcmil (ea)	1/0
DC INPUT C	DC Input from Ext. Battery source to UPS (1) positive, (1) negative, (1) mid-point	VDC (nominal) Amps*	+240 0 -240 167
	Minimum conductor size	AWG or kcmil (ea)	4/0
AC OUTPUT D	AC Output to Critical Load - Full Load Current 3 phase, 1 neutral, 1 ground	Amps*	97
	Minimum conductor size	AWG or kcmil (ea)	1/0

* Full load, nominal voltage

Note: Refer to Figure A – 3 on system one line diagram for the bold letter callout locations.

Read and understand the following notes while planning your installation:

1. Refer to national and local electrical codes for acceptable external wiring practices.
2. Material and labor for external wiring requirements are to be provided by designated personnel.
3. For external wiring, use 90°C copper wire. See the appropriate column in Tables A and B. When wiring to an external battery cabinet, either 75 °C or 90 °C wiring may be used.
4. Wire ampacities are chosen from Table 310-16 of the NEC.
5. A neutral feeder is required for both the main and bypass inputs to this system.
6. Refer to section 1 of this manual for installation instructions.

**Table B. INPUT/OUTPUT Ratings & External Wiring Requirements for
Powerware 9335 – 120 kVA**

<i>Ratings</i>		<i>Units</i>	<i>Rating 50/60 Hz</i>
Basic unit ratings at 0.8 lagging PF load		kVA	120
		kW	96
		INPUT/OUTPUT VOLTAGE	480
AC INPUT A	AC Input to UPS Rectifier (0.95 min.PF) 3 phase, 1 neutral, 1 ground Minimum conductor size *Max. amps include full load current plus battery recharge current	Amps*	150
		AWG or kcmil (ea)	4/0
AC INPUT B	AC Input to UPS Bypass - Full Load Current 3 phase, 1 neutral, 1 ground Minimum conductor size (number/phase)	Amps*	144
		AWG or kcmil (ea)	4/0
DC INPUT C	DC Input from Ext. Battery source to UPS (1) positive, (1) negative, (1) mid-point Minimum conductor size (number/pole)	VDC (nominal) Amps*	+288 0 -288 176
		AWG or kcmil (ea)	4/0
AC OUTPUT D	AC Output to Critical Load - Full Load Current 3 phase, 1 neutral, 1 ground Minimum conductor size (number/phase)	Amps*	144
		AWG or kcmil (ea)	4/0

*Full load, nominal voltage

Note: Refer to Figure A – 3 on system one line diagram for the bold letter callout locations.

7. Terminals are UL rated at 90° C. Refer to Table C for power cable terminations and Table D for conduit requirements. Figure A-1 shows the location of power cable terminals inside the UPS.

Table C. UPS Cabinet Power Cable Terminations for Powerware 9335 (80 kVA & 120 kVA)						
<i>Terminal Function</i>	<i>Terminal</i>	<i>Function</i>	<i>Size of Pressure Termination</i>	<i>Vendor</i>	<i>Tightening Torque N-M (lb-in.)</i>	<i>Int.Hex Size (in.)</i>
AC Input to UPS Rectifier	A	Phase A	1 - #6-250 kcmils	Cooper	42.4 (375)	3/8
	B	Phase B	1 - #6-250 kcmils	Cooper	42.4 (375)	3/8
	C	Phase C	1 - #6-250 kcmils	Cooper	42.4 (375)	3/8
	N	Neutral	1 - #6-250 kcmils	Cooper	42.4 (375)	3/8
AC Input to Bypass (Dual Input)	A	Phase A	1 - #6-250 kcmils	Cooper	42.4 (375)	3/8
	B	Phase B	1 - #6-250 kcmils	Cooper	42.4 (375)	3/8
	C	Phase C	1 - #6-250 kcmils	Cooper	42.4 (375)	3/8
	N	Neutral	1 - #6-250 kcmils	Cooper	42.4 (375)	3/8
AC Output to Critical Load	A	Phase A	1 - #6-250 kcmils	Cooper	42.4 (375)	3/8
	B	Phase B	1 - #6-250 kcmils	Cooper	42.4 (375)	3/8
	C	Phase C	1 - #6-250 kcmils	Cooper	42.4 (375)	3/8
	N	Neutral	1 - #6-250 kcmils	Cooper	42.4 (375)	3/8
DC Input from Battery to UPS	+	Battery(+)	1 - #6-250 kcmils	Cooper	42.4 (375)	3/8
	N	Mid-point	1 - #6-250 kcmils	Cooper	42.4 (375)	3/8
	-	Battery (-)	1 - #6-250 kcmils	Cooper	42.4 (375)	3/8
Customer Ground	Protective Ground	Protective Ground	4 - #6-250 kcmils	Cooper	As Required	

8. Per NEC article 300-20 (a), all three-phase conductors must be run in the same conduit. Neutral and ground must be run in the same conduit as the phase conductors.
9. Conduit is sized to accommodate one neutral conductor the same size as the phase conductor and one protective ground wire of the same size.
10. Conduit sizes were chosen from NEC Table C1, type letters RHH, RHW, RHW-2, TW, THW, THHW, and THW-2.

Table D. Power Cable Conduit Requirements Powerware 9335 (80 kVA & 120 kVA)				
Powerware Product Model	Terminal	Wires in Conduit	Minimum Conduit Size (in.)	No. of Conduits
9335-80 kVA	Rectifier Input (A,B,C,N,G)	5	2.0 inches	1
	Bypass Input (A,B,C,N,G)	5	2.0 inches	1
	Ext. Battery Source (+,N,-,G)	4	2.5 inches	1
	Output (A,B,C,N,G)	5	2.0 inches	1
9335-120 kVA	Rectifier Input (A,B,C,N,G)	5	2.5 inches	1
	Bypass Input (A,B,C,N,G)	5	2.5 inches	1
	Ext. Battery Source (+,N,-,G)	4	2.5 inches	1
	Output (A,B,C,N,G)	5	2.5 inches	1

11. External overcurrent protection is not provided by this product, but is required by codes. Refer to A and B for wiring requirements. If an output lockable disconnect is required, it is to be supplied by designated personnel.
12. Table E lists the maximum rating for input circuit breakers.
13. Battery voltage is computed at 2 volts per cell as defined by Article 480 of the NEC. Rated battery current is computed at the computed voltage.

Table E. Maximum Input Circuit Breaker Ratings (Amperes)		
<i>Powerware Model</i>	<i>Input Voltage Rating</i>	
	480 VAC	DC
9335 – 80 kVA	150	225
9335 – 120 kVA	225	300

CAUTION:

To reduce the risk of fire, connect only to a circuit provided with maximum input circuit breaker current ratings from Table E in accordance with the National Electric code, ANSI/NFPA 70.

14. The input and bypass feeds should be symmetrical about ground.
15. The line-to-line unbalanced output capability of the Powerware 9335 UPS is limited only by the full load per phase current values for AC output to critical load shown in Tables A and B.
16. Output overcurrent protection and output disconnect switches are to be provided by the user. Table F lists the maximum rating for output circuit breakers satisfying the criteria for both.

Table F. Maximum Output Circuit Breaker Ratings (Amperes)	
<i>Powerware Model</i>	<i>Rated Output voltage</i>
	480 VAC
9335 – 80 kVA	150
9335 – 120 kVA	225

1. Use Class 1 wiring methods (as defined by the NEC) for control wiring. Install the control wiring in separate conduit from the power wiring. The wire should be rated at 150 volts, 5 amperes minimum.
2. Refer to tables G, H, and I and to Chapters 2, 4, and 11 of this manual for customer interface wiring.

Table G. Customer Interface Inputs and Outputs

Terminal	Name	Description
X1	Emergency Power Off	X1 – 1 and X1 – 2 (no polarity)
X2	Generator On	X2 – 1 and X2 – 2 (no polarity)
X3	Battery temperature sensor	X3 – 1 and X3 – 2 (no polarity)
X4	Battery Shunt trip breaker control	X4 – 1 and X4 – 2 (+12V & com)
JD-1-1	Not Used	Not Used
JD-1-2	TXD	Input to UPS
JD-1-3	RXD	Output from UPS
JD-1-4	Not Used	Not Used
JD-1-5	Return	Common
JD-1-6	Not Used	Not Used
JD-1-7	Not Used	Not Used
JD-1-8	Not Used	Not Used
JD-1-9	Not Used	Not Used
JD-2-1	Utility Fail Alarm (NO)	Utility Fail Alarm
JD-2-2	Utility OK	Utility Present
JD-2-3	Common	Common
JD-2-4	Load on Inverter message (NO)	Load on inverter message
JD-2-5	Load on inverter message (NC)	Load not on inverter message
JD-2-6	Common	Common
JD-2-7	Battery Low Alarm (NO)	Battery voltage low alarm
JD-2-8	Battery OK	Battery voltage OK
JD-2-9	Common	Common
JD-2-10	Load on utility (bypass mode)	Load on utility/bypass
JD-2-11	Load on utility/bypass (NC)	Load not on utility/bypass
JD-2-12	Common	Common
JD-2-13	Common Alarm (NO)	Common alarm
JD-2-14	No alarm condition	No alarm
JD-2-15	Common	Common
JD-2-16	Not used	Not used
JD-2-17	Not used	Not used
JD-2-18	Not used	Not used
JD-2-19	Not used	Not used
JD-2-20	Not used	Not used
JD-2-21	Not used	Not used
JD-2-22	Ground	Ground
JD-2-23	+12 volts	+12 volts ($I_{max.} = 100 \text{ ma.}$)
JD-2-24	Not used	Not used
JD-2-25	Not used	Not used

Table H. Definition of pin connections on JD2 (25 pin DB-25P/F)

Pin	Contact	Signal		Function
1		ALARM	MNS	Mains failure
2				Mains present
3				Common
4		Message	LD-INV	Load on inverter
5				
6				Common
7		Alarm	BATT_LOW	Battery low
8				Battery OK
9				Common
10		Message	LD_MNS	Load on Mains (BYPASS mode)
11				
12				Common
13		Alarm	COMMON_ALARM	Common Alarm
14				No Alarm Condition
15				Common
16		NC		Not Connected
-				
19				
20				For future use
21				For future use
22		PS_12		GND
23		PS_12		+ 12V (Imax = 100 mA)
24				Not Connected
25				Not Connected

Contacts are rated at 60 volts maximum DC or 30 volts RMS AC, and 500 mA. maximum current and should be supplied by a LVLE source in compliance with UL 1778

Table I. Definition of pins on JD1 and interface cable connections to 9 or 25 pin connectors.

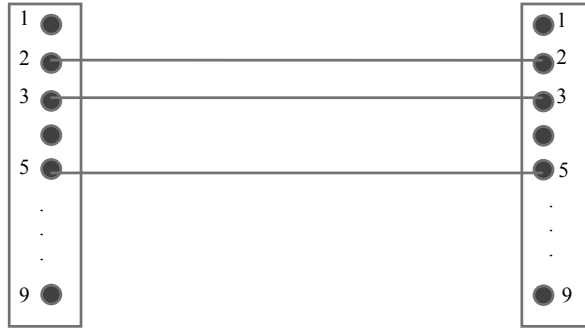

JD1 connector at UPS

DB-9 connector to computer

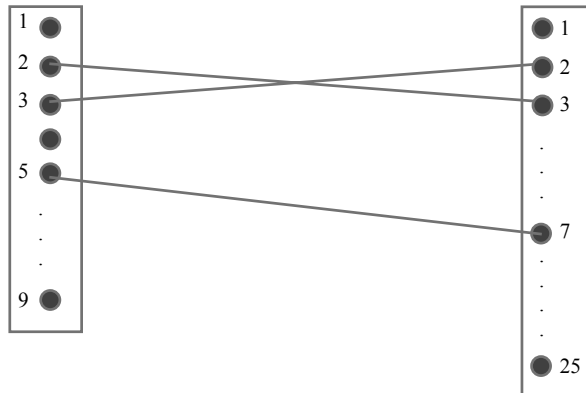

JD1 connector at UPS

DB-25 connector to computer

1. The UPS equipment operating environment must meet the size and weight requirements shown in Table J, according to your UPS system configuration.
2. In this UPS system, the UPS, associated battery cabinets and any additional system elements are all palletted separately for shipping.
3. Do not tilt cabinets more than $\pm 10^\circ$ during handling.
4. All equipment dimensions are shown in millimeters (inches).

Table J. Equipment Weight			
<i>Powerware Model</i>	<i>Weight Kg (lbs.)</i>		
	<i>Shipping</i>	<i>Installed</i>	<i>Point Loading</i>
9335 – 80 kVA	360 (792)	333 (733)	4 at 83 (183)
9335 – 120 kVA	367 (807)	340 (748)	4 at 85 (187)

5. The clearances required around the UPS system are shown in Table K.

Table K. System Clearances	
From Front of Cabinet	36 inches working space
From Back of Cabinet	30 inches working space
From Right or Left side of Cabinet	~0 inches clearance

6. The basic environmental requirements for operation of the UPS system are:

Ambient Temperature Range: 0 – 40°C. (32 – 104°F.)

Recommended Operating Range: 20 – 25°C. (68 – 77°F.)

Maximum Relative Humidity: 95% (non-condensing)

The UPS ventilation requirements for heat removal are shown in Table L.

Table L. Air Conditioning or Ventilation Requirements During Full Load Operation Powerware 9335 80kVA and 120 kVA		
<i>Powerware Model</i>	<i>Input/Output Voltage</i>	<i>Heat Rejection BTU/hr x 1000/hr (g-cal/hr)</i>
9335 – 80 kVA	480/480 linear load pf = 0.8	14.0 (3.5)
9335 – 120 kVA	480/480 linear load pf = 0.8	20.8 (5.2)
9335 – 80 kVA	480/480 linear load pf = 1.0	16.4 (4.2)
9335 – 120 kVA	480/480 linear load pf = 1.0	24.6 (3.1)
9335 – 80 kVA	480/480 100% non-linear load	17.7 (4.4)
9335 – 120 kVA	480/480 100% non-linear load	26.6 (6.6)

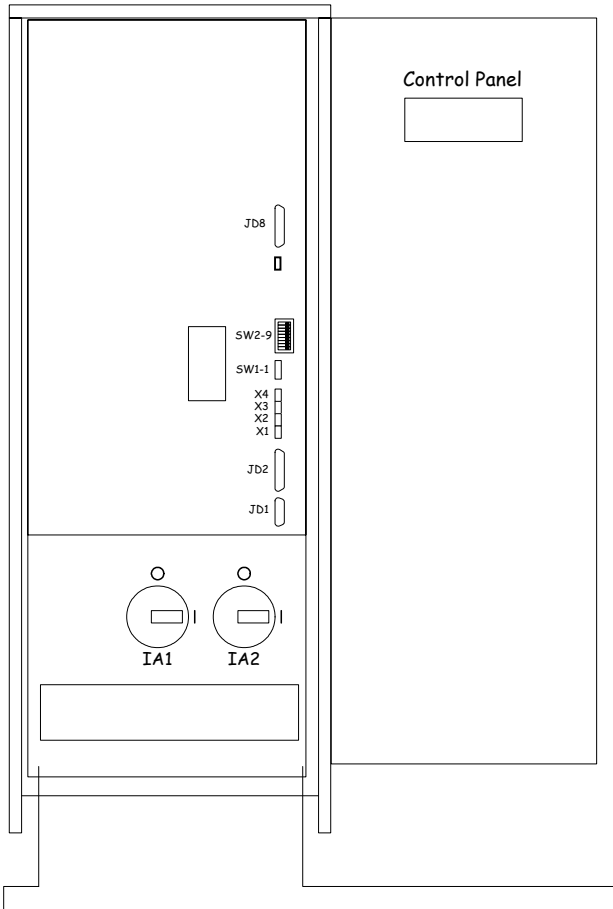

ELEMENTS:

- IA1 Maintenance Bypass
- IA2 Parallel Isolator
- JD1 Smart Port- RS232 (SUB-D9P/F)
- JD2 Dry Port-volt-free relays (SUB-D25/F)
- JD8 Parallel Port
- SW1-1 Single/Parallel Switch
- SW2-9 System Configuration Switches
- X1 Emergency Power OFF (EPO)
- X2 Generator ON
- X3 Battery Temperature
- X4 Battery Breaker control

SW1-1	Module Type
HIGH	Single Module
LOW	Parallel Module

SW2-9	Single Cabinet
1	ON
2	ON
3	ON
4	ON
5	ON
6	ON
7	ON
8	ON
9	ON

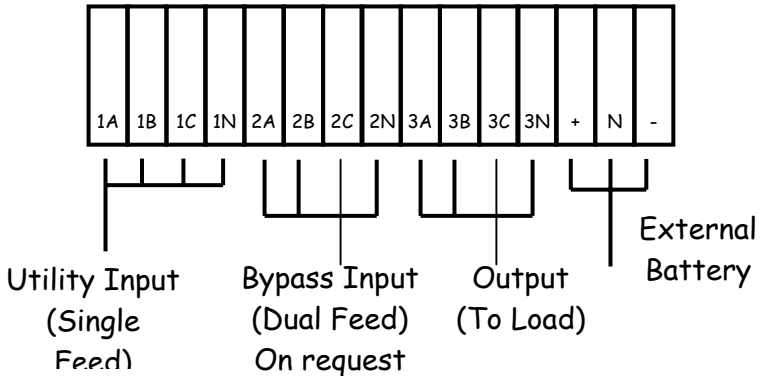

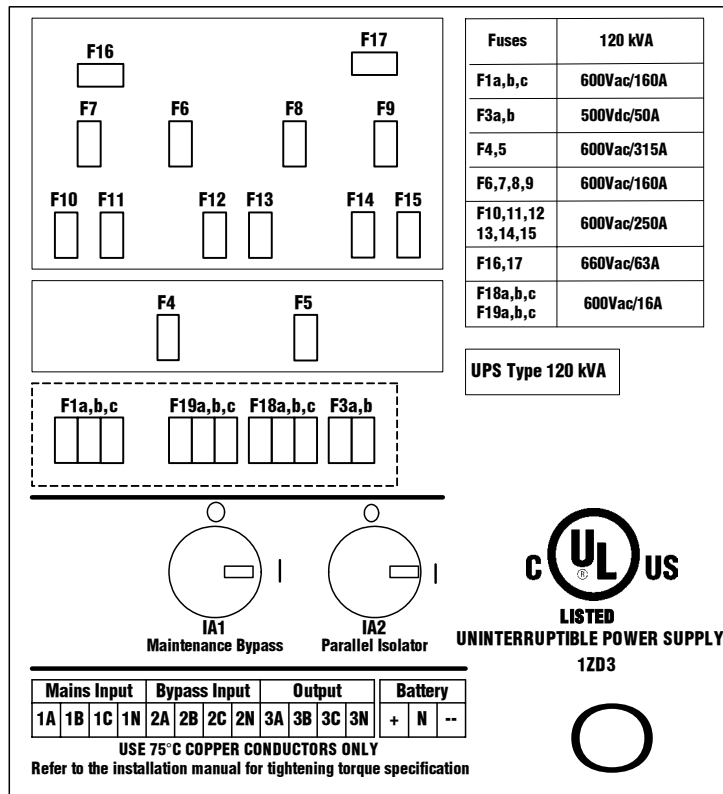
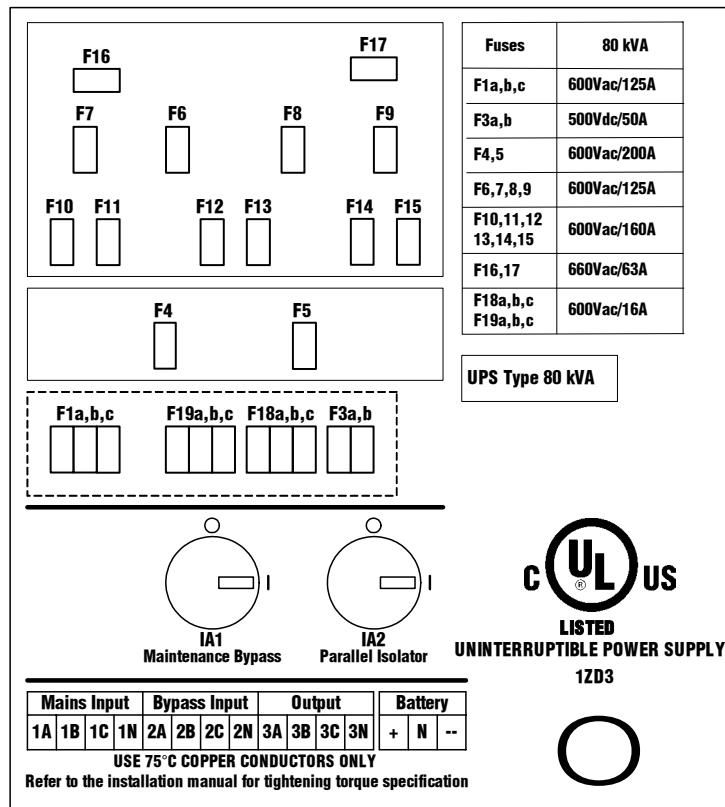

Figure A-2. Powerware 9335 80 kVA and 120 kVA Label

STANDARD VERSION (DUAL INPUT FEED CONNECTION) SHOWN

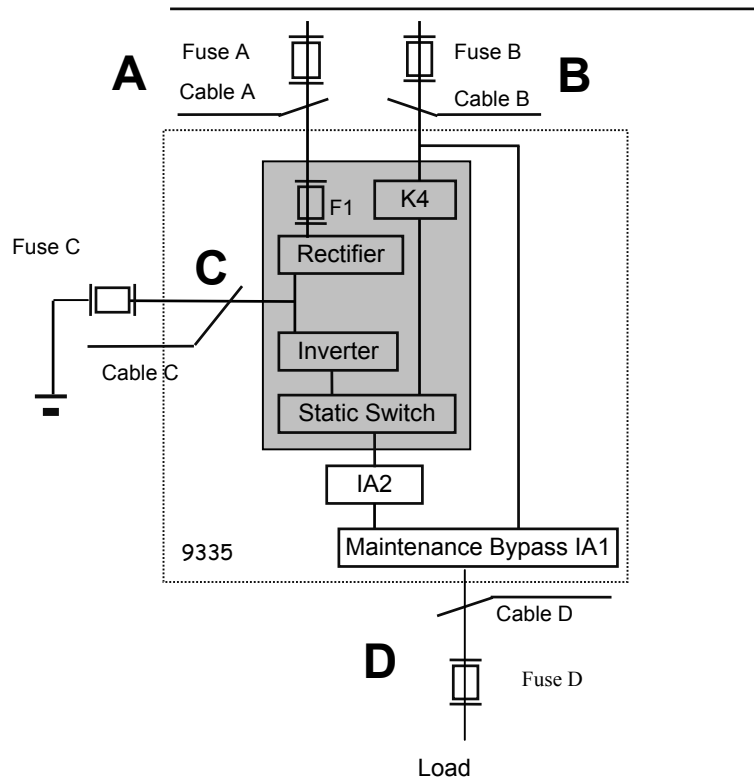

Figure A-3. Powerware 9335 Oneline Drawing

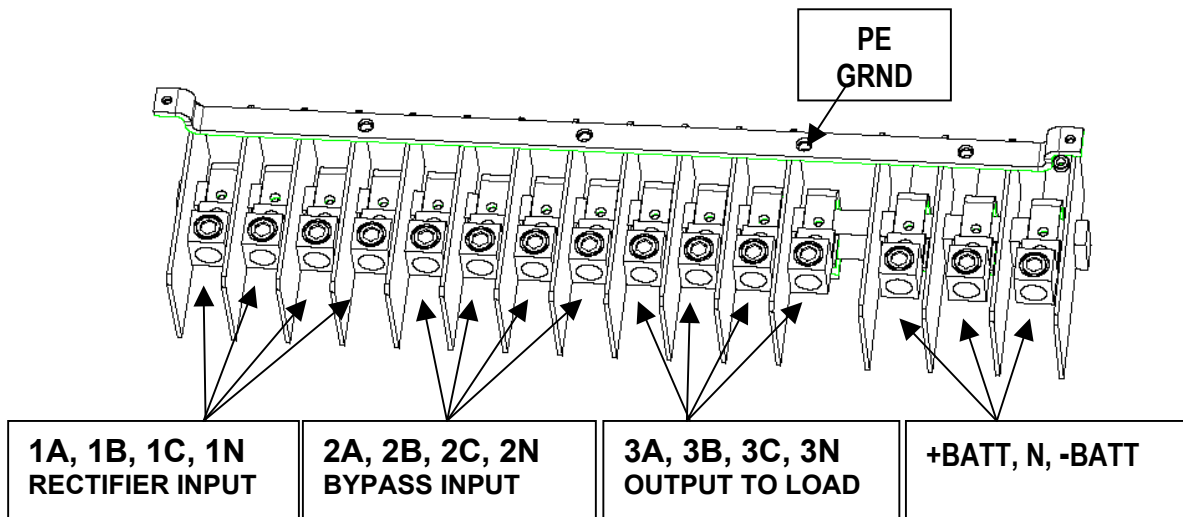

Figure A-4. Power Terminals on Powerware 9335

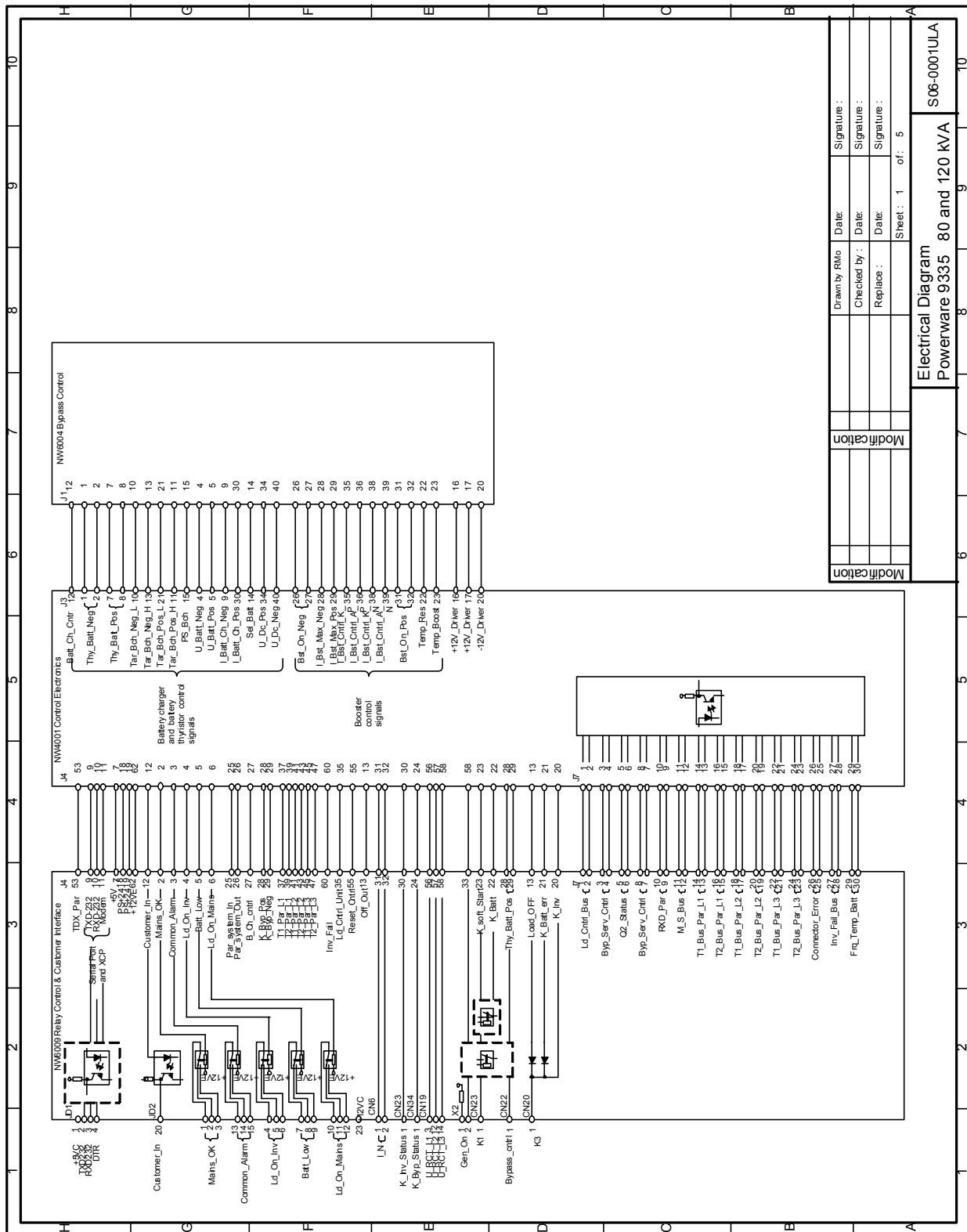

Figure A-5. System Information

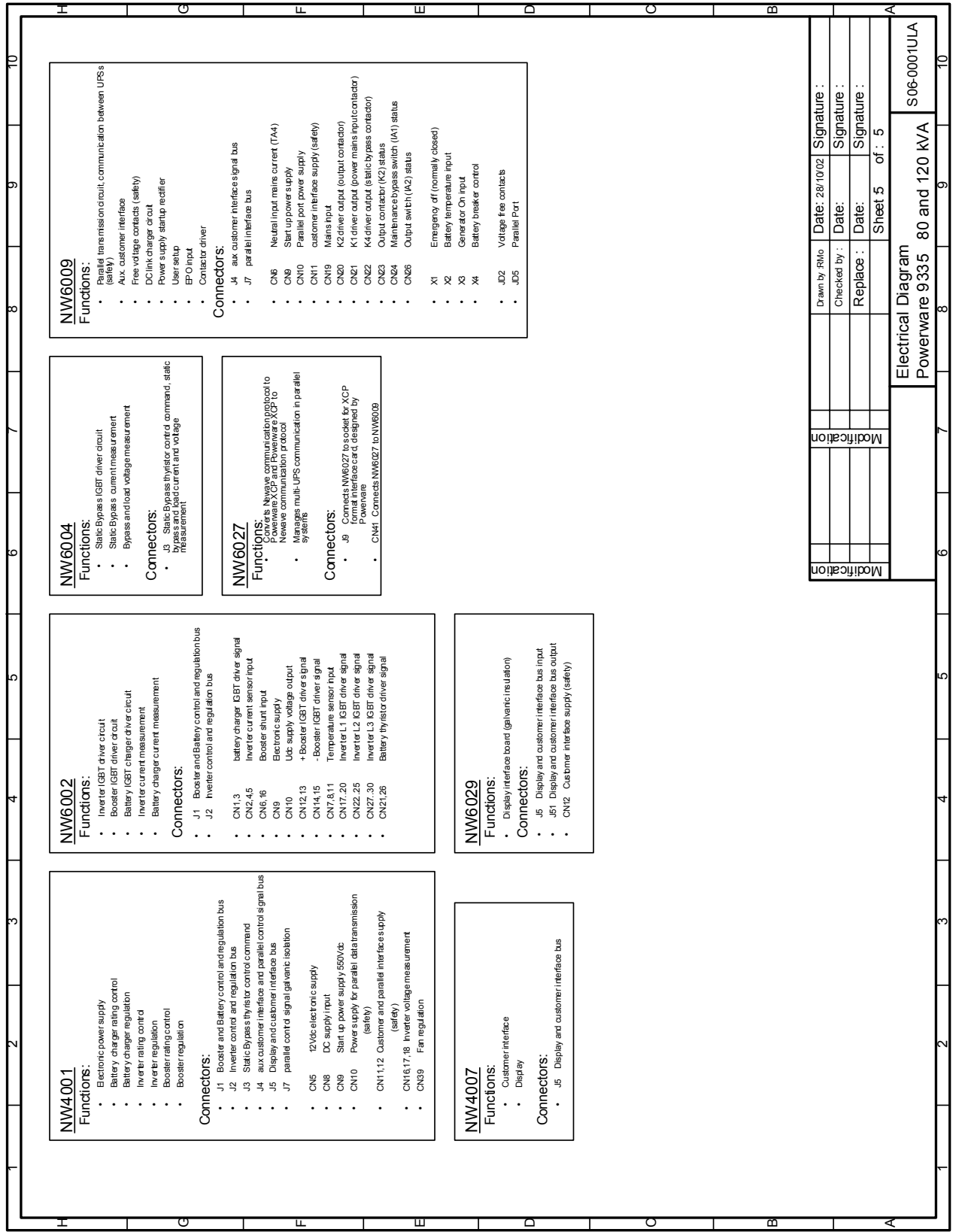

Figure A-6. System Information

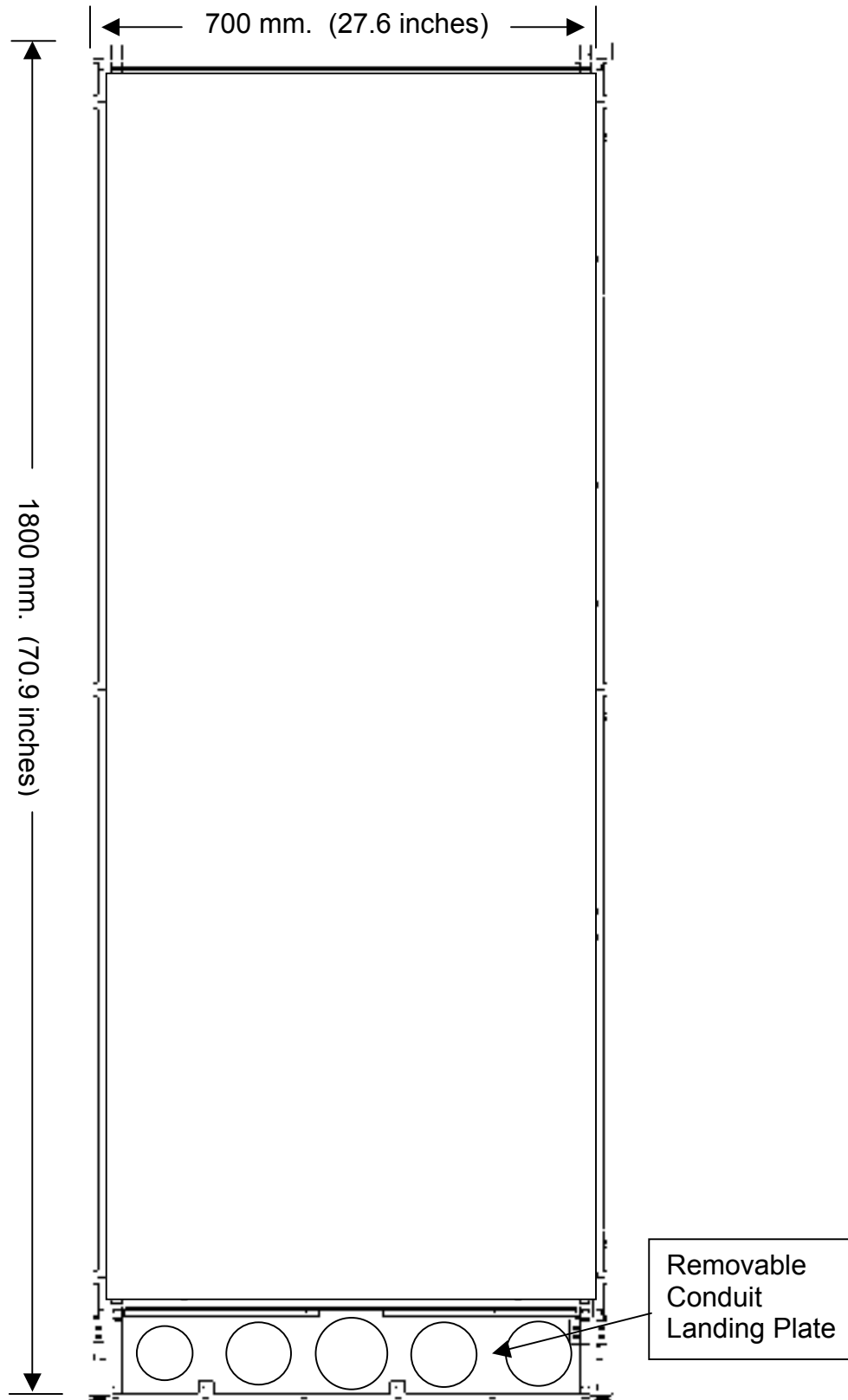

Figure A-7. UPS Cabinet Dimensions (Rear View)

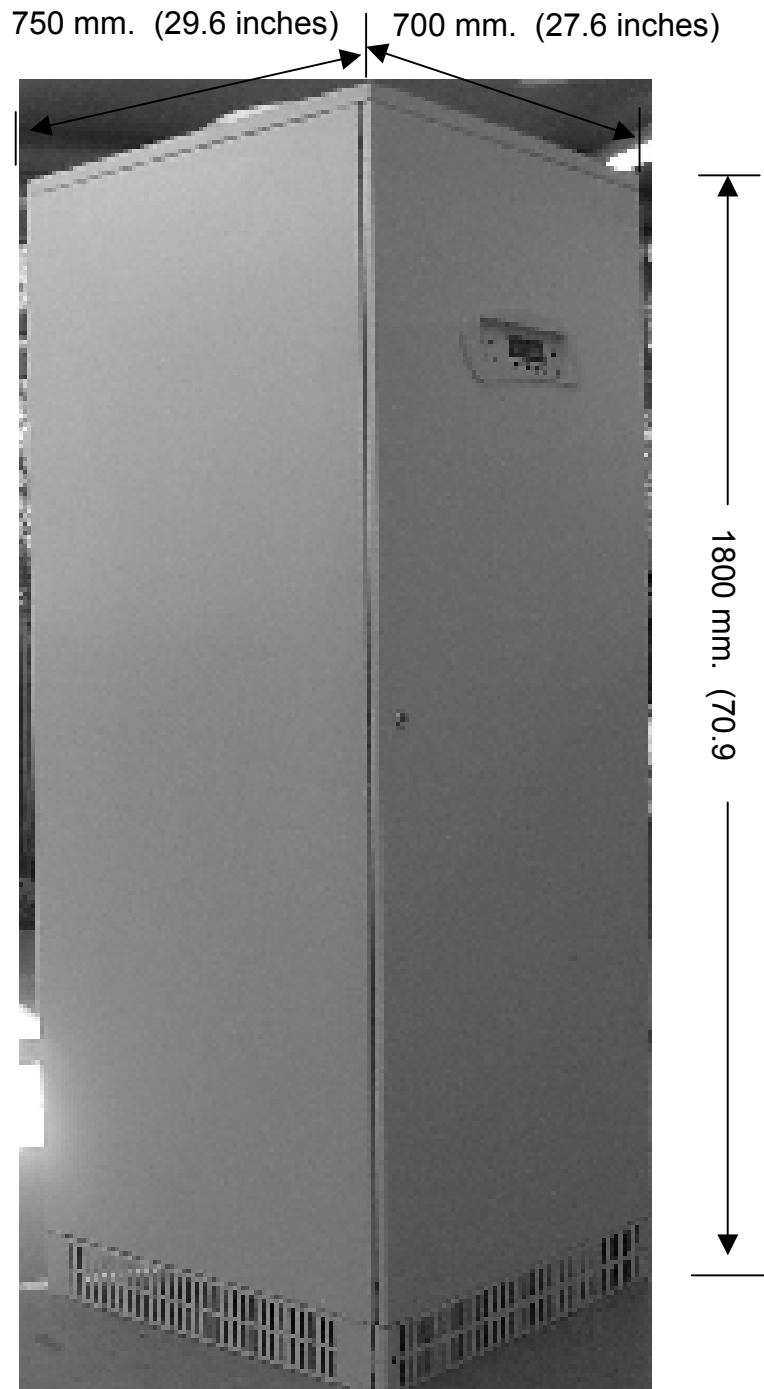

Figure A-8. UPS Cabinet Dimensions

SYSTEM SPECIFICATIONS

SYSTEM MODEL NO.: 1CR4-40TC100S-480C-M22S-524-A/S-UL
 SYSTEM RATING: 70.33 KWH FOR 16 MINUTES TO 1.70 VPC.
 RECOMMENDED SYSTEM FLOAT VOLTAGE: 540 MIN. 552 MAX.
 SYSTEM CUTOFF VOLTAGE: 408
 FULL LOAD CURRENT: 172.38 ADC
 OPEN CIRCUIT VOLTAGE: 496 - 516 VDC
 SHUNT TRIP 24 V

INSTALLATION AND MAINTENANCE

CAUTION: REFER TO INSTALLATION INSTRUCTIONS (IIS-1) PRIOR TO INSTALLING CABINET.

- 1) ALL RECOMMENDED CUSTOMER'S CABLE GAUGES ARE BASED ON TABLE 310-16 OF N.E.C. USING 75°C CABLE.
- 2) INTERNAL BREAKER IS FOR OVERCURRENT PROTECTION ONLY.
- 3) INITIAL CONNECTION TORQUE VALUES 275 IN-LB BREAKER
- 4) USE INSULATED TOOLS FOR CABINET INSTALLATION. DO NOT ALLOW TOOLS OR CABLES TO REST ON BATTERIES.
- 5) TERMINATIONS FOR CUSTOMER'S CABLE ARE RATED FOR 75°C. AMPACITIES OF CUSTOMER'S CABLE MUST NOT CAUSE THIS RATING TO BE EXCEEDED.

IMPORTANT NOTES

**THE CUSTOMER AND/OR CONTRACTOR SHALL BE RESPONSIBLE FOR INSTALLING THIS EQUIPMENT IN ACCORDANCE WITH ALL APPLICABLE CODES AND REGULATIONS

**MIN HANDLING KEEP UPRIGHT WITHIN +/- 15 DEGREES.

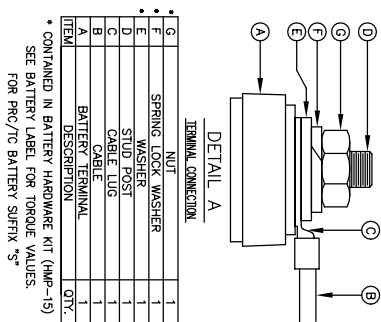

IMPORTANT NOTE
 ALL CONNECTIONS TO BE RETORQUED ANNUALLY.
 ALL CONNECTIONS MUST BE CHECKED FOR PROPER TORQUE PRIOR TO START UP OR ENERGIZING OF SYSTEM.

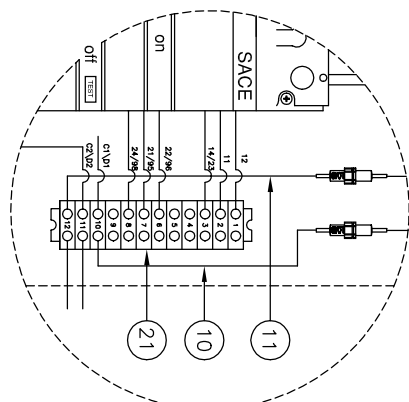

*** PLACE CORNER PROTECTOR BETWEEN BATTERIES FOR VENTILATION PURPOSES.

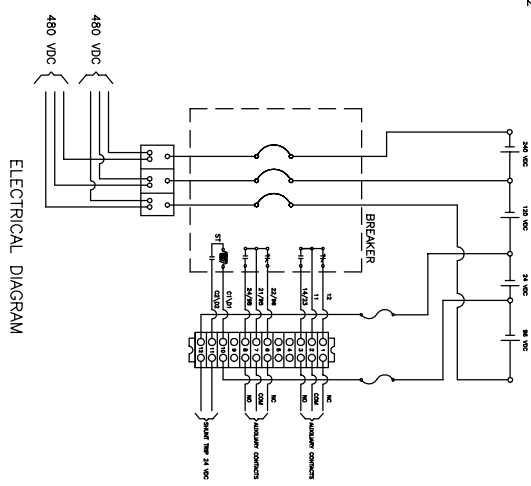
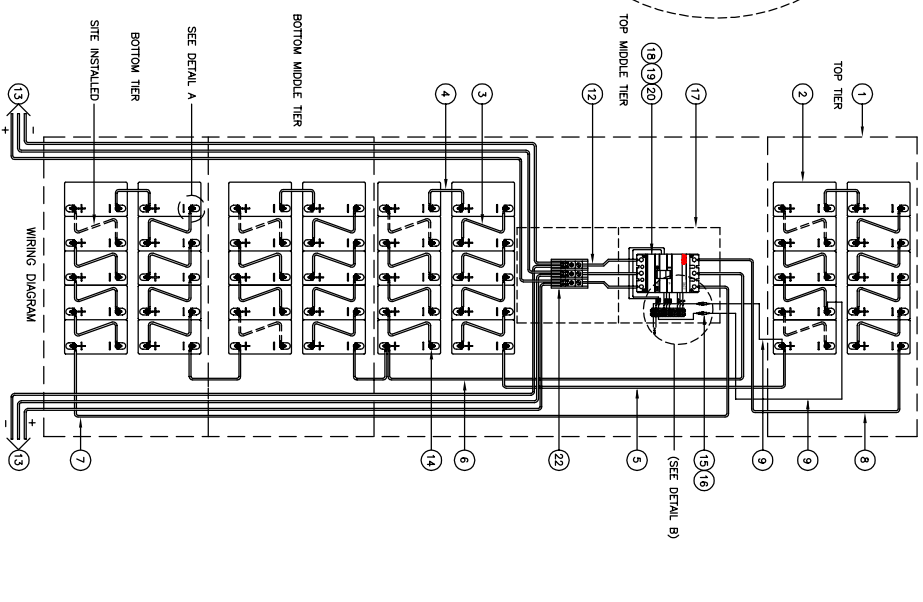
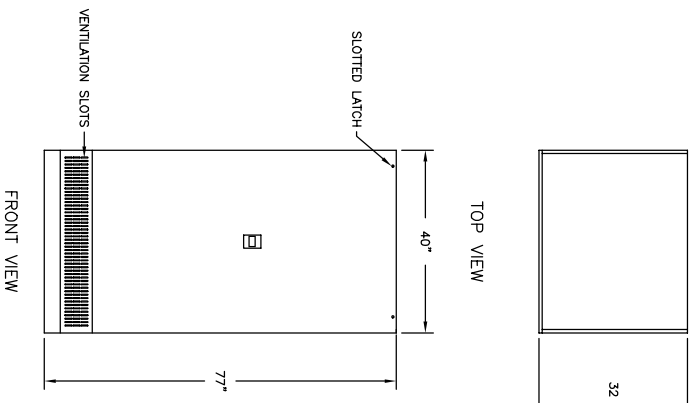
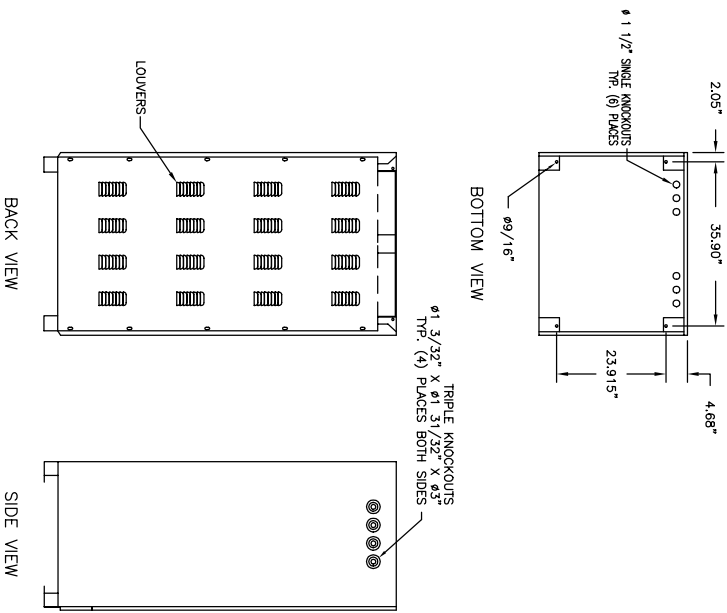
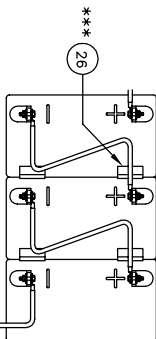

NO.	DESCRIPTION	QTY.	PART NO.
27	CABLE LUG SET (K4TC-2)	1	CR-0226
26	CORNER PROTECTORS	36	CC-0133
25	BATTERY RAIL INSULATION	18	
24	SHUNT TRIP CONNECTORS (K6C-SU)	1	CR-0194
23	AUXILIARY CONNECTORS (K6C-4B)	1	CR-0195
22	TERMINAL BLOCK (3 POLE)	1	IB-0073
21	TERMINAL BLOCK (12 POLE)	1	IB-0026
20	AUXILIARY SWITCH (K5NS)	1	CR-0193
19	SHUNT TRIP 24 V (K58S)	1	CR-0197
18	BREAKER 750 VDC 225 A (3 POLE)	1	F225M
17	BREAKER PLATE	1	CR-0006
16	FUSE HOLDER	2	FS-0079
15	FUSE 500 VDC 5A	2	FS-0077
14	BATTERY HARDWARE KIT	40	SEE DETAIL A
13	CABLE 4/0 GA. MINIMUM	4	SHIPPED BY CUSTOMER
12	CABLE 4/0 GA. 12' LG.	3	4/0-12N
11	CABLE 10 GA. 20' LG.	1	10-20NC
10	CABLE 10 GA. 15' LG.	1	10-15NC
9	CABLE 10 GA. 25' LG.	2	10-25BN
8	CABLE 1 GA. 65' LG.	1	1-65BE
7	CABLE 1 GA. 85' LG.	1	1-85BE
6	CABLE 1 GA. 45' LG.	3	1-45BE
5	CABLE 1 GA. 14' LG.	4	1-14B
4	CABLE 1 GA. 14' LG.	36	1-14B
3	BATTERY	40	TO-12100S
2	CABINET	1	CR4
1		1	CR4

POWER
 POWER BATTERY COMPANY INC.
 BATTERY SYSTEM LAYOUT FOR
 (1) CR4 CABINET (480 V.) WITH
 (40) 12 V. BATTERIES & BREAKER
 DRAWING NO. 1CR4-40TC100S-480

SYSTEM SPECIFICATIONS

SYSTEM MODEL NO.: 1CR4-40T0655-480C-M225-S24-A/S-UL
 SYSTEM RATING: 70.33 KVA FOR 7 MINUTES TO 1.70 VPC.
 RECOMMENDED SYSTEM FLOAT VOLTAGE: 540 MIN. 552 MAX.
 SYSTEM CUTOFF VOLTAGE: 408
 FULL LOAD CURRENT: 172.38 ADC
 OPEN CIRCUIT VOLTAGE: 496 - 516 VDC
 SHUNT TRIP 24 V

INSTALLATION AND MAINTENANCE

CAUTION: REFER TO INSTALLATION INSTRUCTIONS (IIS-1) PRIOR TO INSTALLING CABINET.

- 1) ALL RECOMMENDED CUSTOMER'S CABLE GAUGES ARE BASED ON TABLE 310-16 OF N.E.C. USING 75°C CABLE.
- 2) INTERNAL BREAKER IS FOR OVERCURRENT PROTECTION ONLY.
- 3) INITIAL CONNECTION TORQUE VALUES 275 IN-LB BREAKER
- 4) USE INSULATED TOOLS FOR CABINET INSTALLATION. DO NOT ALLOW TOOLS OR CABLES TO REST ON BATTERIES.
- 5) TERMINATIONS FOR CUSTOMER'S CABLE ARE RATED FOR 75°C. AMPACITIES OF CUSTOMER'S CABLE MUST NOT CAUSE THIS RATING TO BE EXCEEDED.

IMPORTANT NOTES

**THE CUSTOMER AND/OR CONTRACTOR SHALL BE RESPONSIBLE FOR INSTALLING THIS EQUIPMENT IN ACCORDANCE WITH ALL APPLICABLE CODES AND REGULATIONS

**MIN HANDLING KEEP UPRIGHT WITHIN +/- 15 DEGREES.

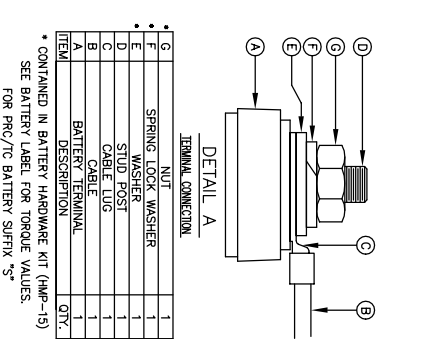
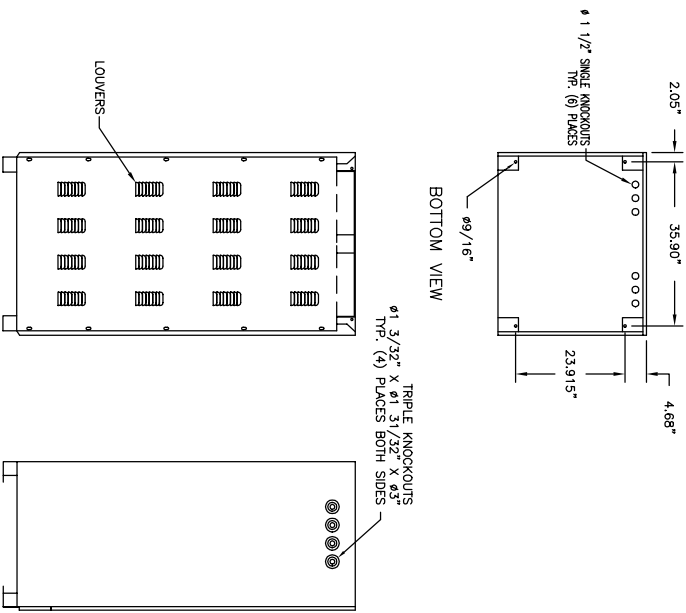

IMPORTANT NOTE
 ALL CONNECTIONS TO BE RETORQUED ANNUALLY.
 ALL CONNECTIONS MUST BE CHECKED FOR PROPER TORQUE PRIOR TO START UP OR ENERGIZING OF SYSTEM.

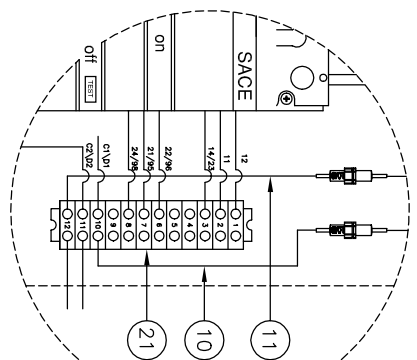

*** PLACE CORNER PROTECTOR BETWEEN BATTERIES FOR VENTILATION PURPOSES

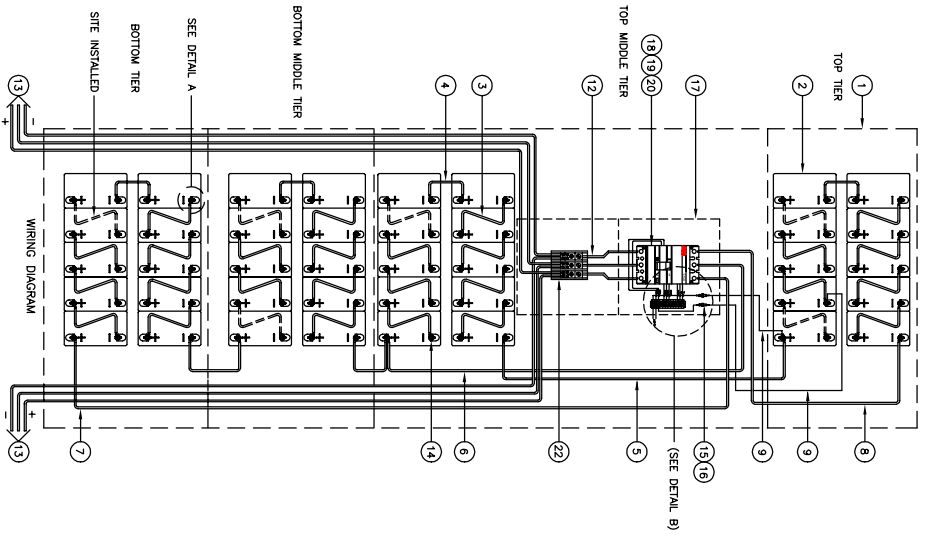
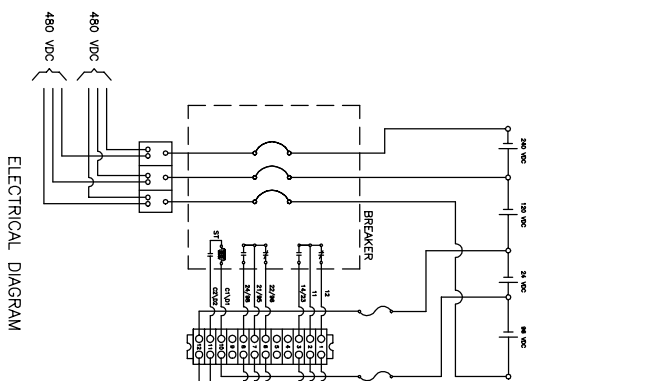
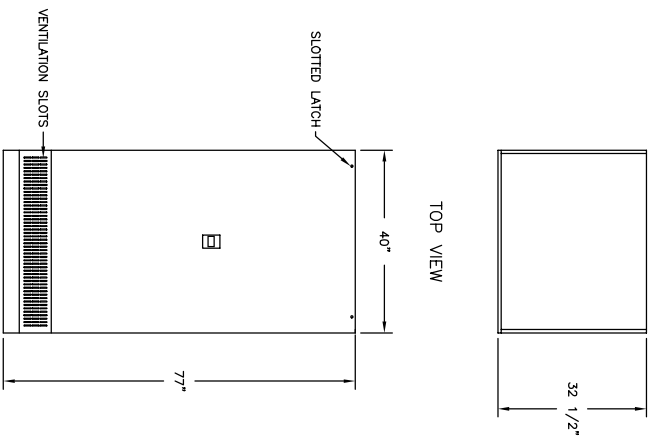
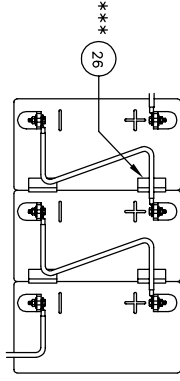

NO.	DESCRIPTION	QTY.	PART NO.
27	CABLE LUG SET (K4TC-2)	1	CR-0226
26	CORNER PROTECTORS	36	CC-0133
25	BATTERY RAIL INSULATION	16	
24	SHUNT TRIP INSULATION (K6C-SU)	1	CR-0194
23	ALUMINUM CONNECTORS (K6C-AB)	1	CR-0195
22	TERMINAL BLOCK (K2 POLE)	1	TB-0074
21	TERMINAL BLOCK (K2 POLE)	1	TB-0026
20	ALUMINUM SWITCH (K5AS)	1	CR-0193
19	SHUNT TRIP 24 V (K5AS)	1	CR-0192
18	BREAKER 250 VDC 225 A (3 POLE)	1	F225M
17	BREAKER PLATE	1	CR-0006
16	FLUSE HOLDER	2	F5-0079
15	FLUSE 500 VDC 5A	2	F5-0077
14	BATTERY HARDWARE KIT	40	SEE DETAIL A
13	CABLE 4/0 GA. ALUMINUM	6	SHRUD BY CUSTOMER
12	CABLE 4/0 GA. 12" LG.	3	4/0-12EN
11	CABLE 10 GA. 20" LG.	1	10-20NC
10	CABLE 10 GA. 15" LG.	1	10-15NC
9	CABLE 10 GA. 25" LG.	2	10-25BN
8	CABLE 1 GA. 65" LG.	1	1-65BE
7	CABLE 1 GA. 85" LG.	1	1-85BE
6	CABLE 1 GA. 40" LG.	1	1-40BE
5	CABLE 1 GA. 45" LG.	3	1-45B
4	CABLE 1 GA. 14" LG.	4	1-14B
3	BATTERY	36	TC-12655
2	CABINET	1	CR4
1	NO. DESCRIPTION	QTY.	PART NO.

POWER
 BATTERY SYSTEM LAYOUT FOR
 (1) CR4 CABINET (480 V.) WITH
 (40) 12 V. BATTERIES & BREAKER

REVISIONS: 09/09/02
 SERIAL #97091
 DATE: 09/09/02

POWER BATTERY COMPANY INC.
 1CR4-40T0655-480

SYSTEM SPECIFICATIONS

SYSTEM MODEL NO.: 1CR5-48TC120S-576C-F300-S24-A/S-UL
 SYSTEM RATING: 105.49 KWH FOR 15 MINUTES TO 1.70 VFC.
 RECOMMENDED SYSTEM FLOAT VOLTAGE: 648 MIN. 662.4 MAX.
 SYSTEM CUTOFF VOLTAGE: 489.6
 FULL LOAD CURRENT: 215.46 ADC
 FULL LOAD CURRENT PER SERIES CIRCUIT: 215.46 ADC
 OPEN CIRCUIT VOLTAGE: 595.2 - 619.2 VDC
 SHUNT TRIP 24 V

INSTALLATION AND MAINTENANCE

CAUTION: REFER TO INSTALLATION INSTRUCTIONS (IIS-1) PRIOR TO INSTALLING CABINET.

- 1 ALL RECOMMENDED CUSTOMER'S CABLE GAUGES ARE BASED ON TABLE 310-16 OF N.E.C. USING 75° C CABLE.
- 2 INTERNAL BREAKER IS FOR OVERCURRENT PROTECTION ONLY.
- 3 INITIAL CONNECTION TORQUE VALUES 275 IN-LB BREAKER
- 4 USE INSULATED TOOLS FOR CABINET INSTALLATION. DO NOT ALLOW TOOLS OR CABLES TO REST ON BATTERIES.
- 5 TERMINATIONS FOR CUSTOMER'S CABLE ARE RATED FOR 75° C. AMPACITIES OF CUSTOMER'S CABLE MUST NOT CAUSE THIS RATING TO BE EXCEEDED.

IMPORTANT NOTES

**THE CUSTOMER AND/OR CONTRACTOR SHALL BE RESPONSIBLE FOR INSTALLING THIS EQUIPMENT IN ACCORDANCE WITH ALL APPLICABLE CODES AND REGULATIONS

**IN HANDLING KEEP UPRIGHT WITHIN +/- 15 DEGREES.

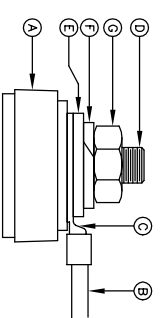

DETAIL A

ITEM	DESCRIPTION	QTY.
C	NUT	1
F	SPRING LOCK WASHER	1
G	WASHER	1
H	STUD POST	1
I	CABLE LUG	1
J	BATTERY TERMINAL	1
K	BATTERY TERMINAL	1
L	BATTERY TERMINAL	1
M	BATTERY TERMINAL	1
N	BATTERY TERMINAL	1
O	BATTERY TERMINAL	1
P	BATTERY TERMINAL	1
Q	BATTERY TERMINAL	1
R	BATTERY TERMINAL	1
S	BATTERY TERMINAL	1
T	BATTERY TERMINAL	1
U	BATTERY TERMINAL	1
V	BATTERY TERMINAL	1
W	BATTERY TERMINAL	1
X	BATTERY TERMINAL	1
Y	BATTERY TERMINAL	1
Z	BATTERY TERMINAL	1

* CONTAINED IN BATTERY HARDWARE KIT (BMP-15)
 SEE BATTERY LABEL FOR TORQUE VALUES.
 FOR PRC/TC BATTERY SUFFIX "S"

IMPORTANT NOTE
 ALL CONNECTIONS TO BE RETORQUED ANNUALLY.
 ALL CONNECTIONS MUST BE CHECKED FOR PROPER TORQUE PRIOR TO START UP OR ENERGIZING OF SYSTEM.

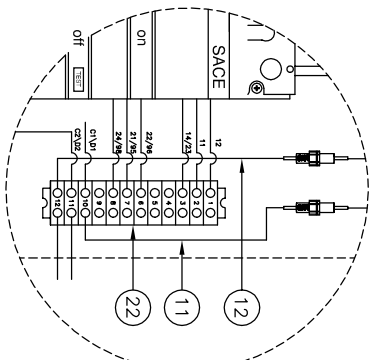

DETAIL B

*** PLACE CORNER PROTECTOR BETWEEN BATTERIES FOR VENTILATION PURPOSES

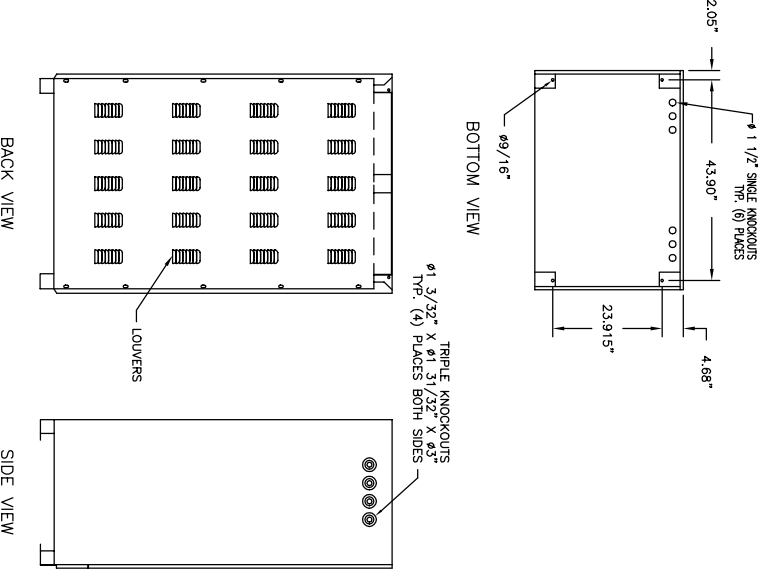
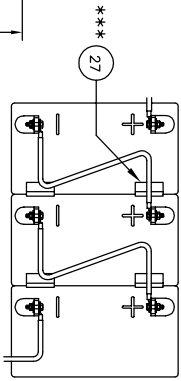

BOTTOM VIEW



SIDE VIEW

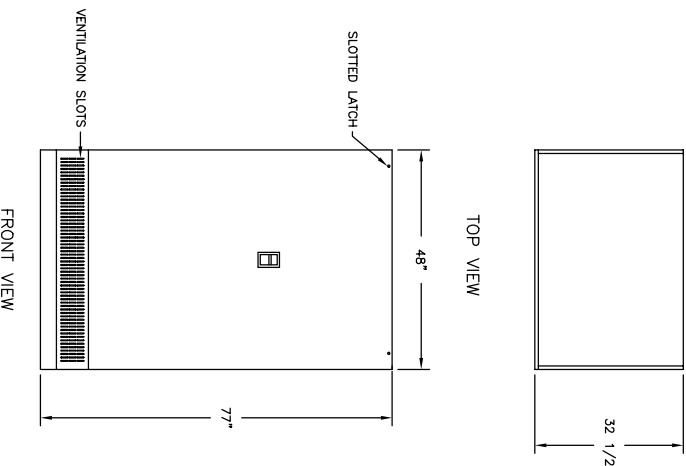

TOP VIEW

FRONT VIEW

BACK VIEW

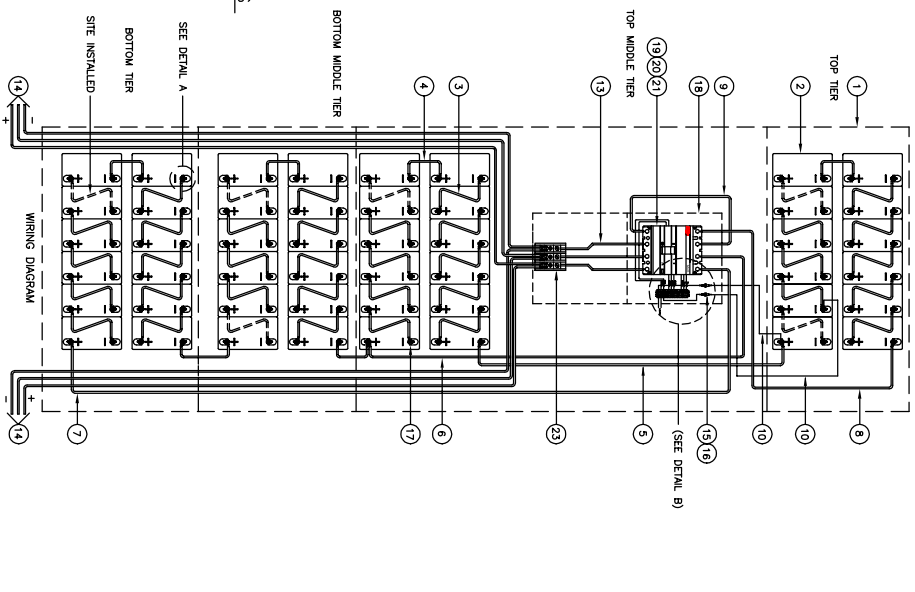

WIRING DIAGRAM

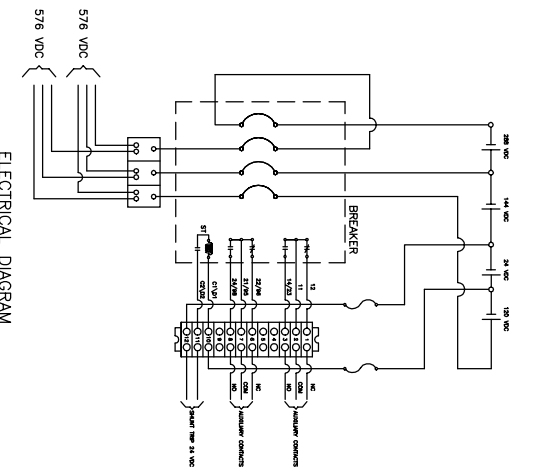

ELECTRICAL DIAGRAM

NO.	DATE	REV.	SCALE	BY	CHKD.	APP'D.	NOT VALID UNLESS APPROVED	FILE NO.	DRAWING NO.
1	09/09/02							CR500194	1CR5-48TC120S-576
2									
3									
4									

NO.	DESCRIPTION	QTY.	PART NO.
1	CABINET	1	CR5
2	BATTERY	48	TC-12120S
3	CABLE	1	1-148
4	CABLE	4	1-158
5	CABLE	1	1-458
6	CABLE	1	1-458E
7	CABLE	1	1-858E
8	CABLE	1	1-858E
9	CABLE	1	1-858E
10	CABLE	2	10-258N
11	CABLE	1	10-158NC
12	CABLE	1	10-20NC
13	CABLE	3	4/0-20N
14	CABLE DOUBLE RUN 1/0 GA. MINIMUM 6x2 SHIPPED BY CUSTOMER	6x2	
15	FUSE HOLDER	2	F3-0077
16	FUSE 500 VDC 5A	2	F3-0079
17	BATTERY HARDWARE KIT	48	SEE DETAIL A
18	BREAKER PLATE	1	CR-0006
19	BREAKER 750 VDC 300 A (4 POLE)	1	CR-300M
20	SHUNT TRIP 24 V (K58S)	1	CR-0197
21	AUXILIARY SWITCH (K58S)	1	CR-0193
22	TERMINAL BLOCK (12 POLE)	1	1B-0076
23	AUXILIARY CONNECTORS (K6C-4B)	1	CB-0195
24	AUXILIARY CONNECTORS (K6C-SU)	1	CB-0194
25	SHUNT TRIP CONNECTORS (K6C-4B)	1	CB-0195
26	BATTERY RAIL INSULATION	16	CC-0133
27	CORNER PROTECTORS	80	CC-0133
28	CABLE LUG SET (K4TD-2)	2	CB-0196



POWER BATTERY COMPANY, INC.
 BATTERY SYSTEM LAYOUT FOR
 (1) CR5 CABINET (576 V.) WITH
 (48) 12 V. BATTERIES & BREAKER

SYSTEM SPECIFICATIONS

SYSTEM MODEL NO.: 1CR5-48TC90S-576C-F300-S24-A/S-UL
 SYSTEM RATING: 105.49 KWH FOR 8 MINUTES TO 1.70 VPC.
 RECOMMENDED SYSTEM FLOAT VOLTAGE: 648 MIN. 662.4 MAX.
 SYSTEM CUTOFF VOLTAGE: 499.6
 FULL LOAD CURRENT: 215.46 ADC
 FULL LOAD CURRENT PER SERIES CIRCUIT: 215.46 ADC
 OPEN CIRCUIT VOLTAGE: 595.2 - 619.2 VDC
 SHUNT TRIP 24 V

INSTALLATION AND MAINTENANCE

CAUTION: REFER TO INSTALLATION INSTRUCTIONS (IIS-1) PRIOR TO INSTALLING CABINET.

- ① ALL RECOMMENDED CUSTOMER'S CABLE GAUGES ARE BASED ON TABLE 310-16 OF N.E.C. USING 75° C CABLE.
- ② INTERNAL BREAKER IS FOR OVERCURRENT PROTECTION ONLY.
- ③ INITIAL CONNECTION TORQUE VALUES 275 IN-LB BREAKER
- ④ USE INSULATED TOOLS FOR CABINET INSTALLATION. DO NOT ALLOW TOOLS OR CABLES TO REST ON BATTERIES.
- ⑤ TERMINATIONS FOR CUSTOMER'S CABLE ARE RATED FOR 75° C. AMPACITIES OF CUSTOMER'S CABLE MUST NOT CAUSE THIS RATING TO BE EXCEEDED.

IMPORTANT NOTES

**THE CUSTOMER AND/OR CONTRACTOR SHALL BE RESPONSIBLE FOR INSTALLING THIS EQUIPMENT IN ACCORDANCE WITH ALL APPLICABLE CODES AND REGULATIONS

***IN HANDLING KEEP UPRIGHT WITHIN +/- 15 DEGREES.

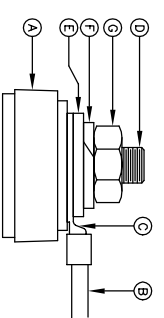

ITEM	DESCRIPTION	QTY.
C	NUT	1
F	SPRING LOCK WASHER	1
D	WASHER	1
E	STUD POST	1
G	CABLE LUG	1
B	BATTERY TERMINAL	1

* CONTAINED IN BATTERY HARDWARE KIT (AMP-15)
 ** SEE BATTERY LABEL FOR TORQUE VALUES.
 *** FOR PRC/TC BATTERY SUFFIX "S"

IMPORTANT NOTE

ALL CONNECTIONS TO BE RETORQUED ANNUALLY. ALL CONNECTIONS MUST BE CHECKED FOR PROPER TORQUE PRIOR TO START UP OR ENERGIZING OF SYSTEM.

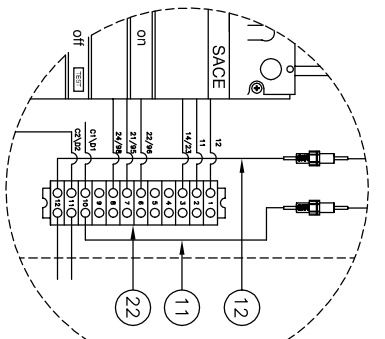

DETAIL B

*** PLACE CORNER PROTECTOR BETWEEN BATTERIES FOR VENTILATION PURPOSES

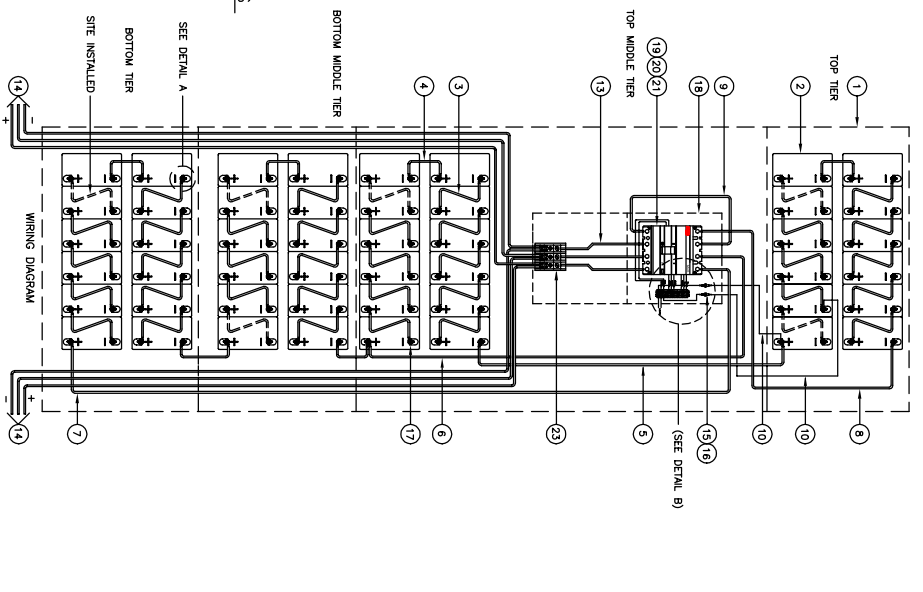
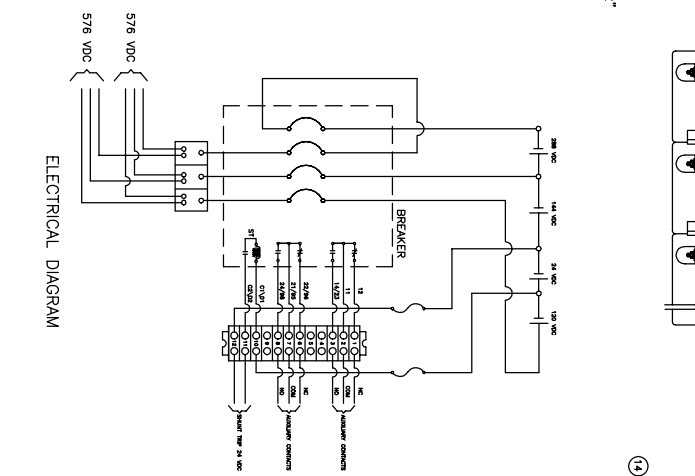
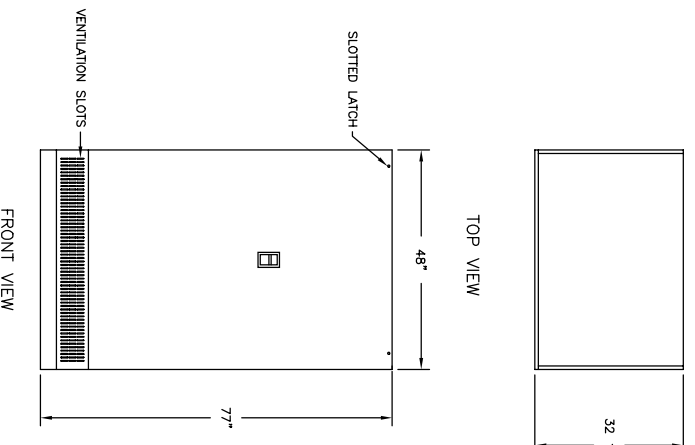
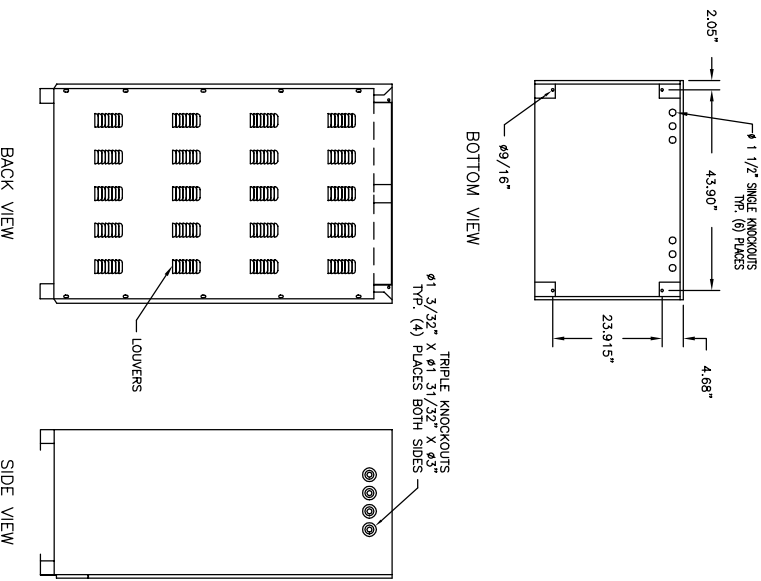
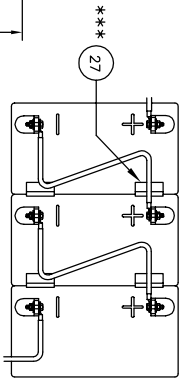

28	CABLE LUG SET (K4TD-2)	2	CB-0196
27	CORNER PROTECTORS	80	CC-0133
26	BATTERY RAIL INSULATION	16	
25	SHUNT TRIP CONNECTORS (K6C-SU)	1	CB-0194
24	AUXILIARY CONNECTORS (K6C-4B)	1	CB-0195
23	TERMINAL BLOCK (3 POLE)	1	TB-0076
22	TERMINAL BLOCK (12 POLE)	1	TB-0026
21	AUXILIARY SWITCH (K6SA)	1	CB-0193
20	SHUNT TRIP 24 V (K6SS)	1	CB-0197
19	BREAKER 750 VDC 300 A (4 POLE)	1	P-300A
18	BREAKER FLATE	2	GF-0006
17	BATTERY HARDWARE KIT	48	SEE DETAIL A
16	FUSE HOLDER	2	FS-0079
15	FUSE 500 VDC 5A	2	FS-0077
14	CABLE DOUBLE RUN 1/0 GA. MINIMUM 6x2 SHIPPED BY CUSTOMER	3	4/0-20N
13	CABLE 4/0 GA. 20' LG.	1	10-20NC
12	CABLE 10 GA. 20' LG.	1	10-20NC
11	CABLE 10 GA. 15' LG.	1	10-15NC
10	CABLE 10 GA. 25' LG.	2	10-25BN
9	CABLE 4/0 GA. 20' LG.	1	4/0-25N
8	CABLE 1 GA. 85' LG.	1	1-85SN
7	CABLE 1 GA. 40' LG.	1	1-40SN
6	CABLE 1 GA. 45' LG.	3	1-45B
5	CABLE 1 GA. 16' LG.	4	1-16B
4	CABLE 1 GA. 14' LG.	40	1-14B
3	BATTERY	48	TC-1290S
2	CABINET	1	CR5
1	NO. DESCRIPTION	QTY.	PART NO.

REVISIONS: SERIAL #97093 09/09/02

POWER BATTERY SYSTEM INC.
 BATTERY SYSTEM LAYOUT FOR (1) CR5 CABINET (576 V.) WITH (48) 12 V. BATTERIES & BREAKER

FILE NO.: CR500194
 DRAWING NO.: 1CR5-48TC90S-576

LIMITED FACTORY WARRANTY FOR THREE-PHASE POWERWARE PRODUCTS

Subject to the conditions herein, *Invensys Powerware* (*Powerware*®) warrants solely, to the original end-user, the electronics (the "Unit"), and *Powerware* built battery cabinets, against defects in material and workmanship for the warranty period of 12 months, from the date of equipment start up, or 18 months from date of shipment, whichever occurs first. Should service be necessary, this warranty covers:

USA only: The *Powerware* 9315, 9330, 9335 three-phase UPS products are sold with a standard factory warranty (described below), start up, and extended labor service. All three-phase UPS installations will have an authorized *Invensys Powerware* Service Engineer or Agent perform startup or the factory warranty and extended labor service will be void. The included first year extended labor service provides for a complete 12 months of onsite labor for your UPS purchase.

Worldwide: All parts requiring replacement for the Factory Warranty period.

If, in the opinion of *Invensys Powerware*, the Unit fails to meet published specifications and the defect is within the terms of this warranty, the Unit will be repaired or replaced at the option of *Invensys Powerware* with no charge for replacement parts. Labor required, to make upgrades, repairs or replacement installation, is not included under the terms of this Limited Warranty, except for labor and travel costs required during the first 90 days of this warranty (USA only), provided that startup of the unit onsite, has been performed by *Invensys Powerware* or its agent. Equipment sold, but not manufactured by *Invensys Powerware*, and only the manufacturer of such equipment shall warrant this equipment and is not included as part of this warranty agreement. Equipment repaired or replaced pursuant to this warranty will be warranted for the remaining portion of the original warranty subject to all the terms thereof.

This warranty is not valid unless an authorized *Invensys Powerware* Service Engineer or Agent performs startup and commissioning. This warranty does not apply to any Unit that has been subject to neglect, accident, abuse, misuse, misapplication, incorrect installation, or that has been subject to repair or alteration, not authorized in writing by *Invensys Powerware* personnel or performed by an authorized *Invensys Powerware* Service Engineer or Agent. Purchaser shall be invoiced for, and shall pay for, all services not expressly provided for by the terms hereof, including, without limitation, site calls involving an inspection that determines no corrective maintenance is required. THIS WARRANTY IS THE PURCHASER'S (USER'S) SOLE REMEDY AND IS EXPRESSLY IN LIEU OF, AND THERE ARE NOT OTHER, EXPRESSED OR IMPLIED GUARANTEES OR WARRANTIES (INCLUDING ANY IMPLIED WARRANTY OF MERCHANTABILITY OR FITNESS FOR ANY PURPOSE, WHICH ARE EXPRESSLY DISCLAIMED). In no case will *Invensys Powerware's* liability under this Warranty exceed the replacement value of the Unit warranted.

Invensys Powerware's obligation, under said warranty, is expressly conditioned upon receipt by *Invensys Powerware* of all payments due it (including interest charges, if any). During such time as *Invensys Powerware* has not received payment of any amount due it, in accordance with the Contract terms under which the equipment is sold, *Invensys Powerware* shall have no obligation, under said warranty; also during this time, the period of said warranty shall continue to run and the expiration of said warranty shall not be extended upon payment of the overdue amount. These limitations, to said warranty, apply even in the event that the equipment is sold initially by *Invensys Powerware* for resale to an ultimate end-user.

In no event shall *Invensys Powerware* be liable for any indirect, incidental special or consequential damages of any kind or type whatsoever, or based on any claim or cause of action, however denominated. *Invensys Powerware* shall not be responsible for failure to provide service or parts due to causes beyond *Invensys Powerware's* reasonable control. This limited warranty applies only to the original end user of the unit.

This factory warranty will not be in effect if the End-User does not properly store the equipment, including the "trickle charge" of batteries no later than the date indicated on the packaging, before installation and does not cover shipping damages if FOB Factory. Cost for replacement equipment, installation, material freight charges travel expenses and labor of *Invensys Powerware* representatives will be borne by the Purchaser (user). Any advice furnished the Purchaser before or after delivery in regard to use or application of *Powerware* equipment is furnished without charge and on the basis that it represents *Invensys Powerware's* best judgment under the circumstances. The use of any such advice by the Purchaser is solely and entirely at its own risk. Any other agreements, such as Service contracts or Sales Concessions are not means to annul this Factory Warranty.

For comment or questions, about this Limited Factory Warranty, write to the Customer Quality Representative, 3301 Spring Forest Road, Raleigh, NC 27601, or call (919) 872---3020

This page left intentionally blank