

### **Standard Features**

- ▶ When used with standard system, EX RT Transformer Module provides isolated and Step-down 120/208/240 Vac outputs.
- ▶ Multiple Output receptacles: 120/208/240 Vac.



# **E X RT Transformer**

## ***Installation and User Manual***

86-86000-03 AO

## STEP 1 EX RT Transformer Unpacking and Parts Check

### EX RT Transformer Box Contents



EX RT Transformer Installation and User Manual



Tower Stand Extenders

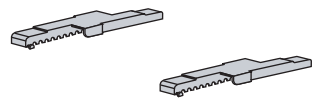

Stabilizer Bracket (4 screws included)

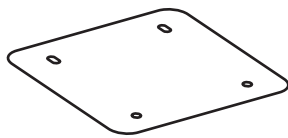

## STEP 2 EX RT Transformer Tower Configuration

### Tower Configuration of Standard System with Transformer Module



Transformer

Power Module

Battery Module (up to 6)

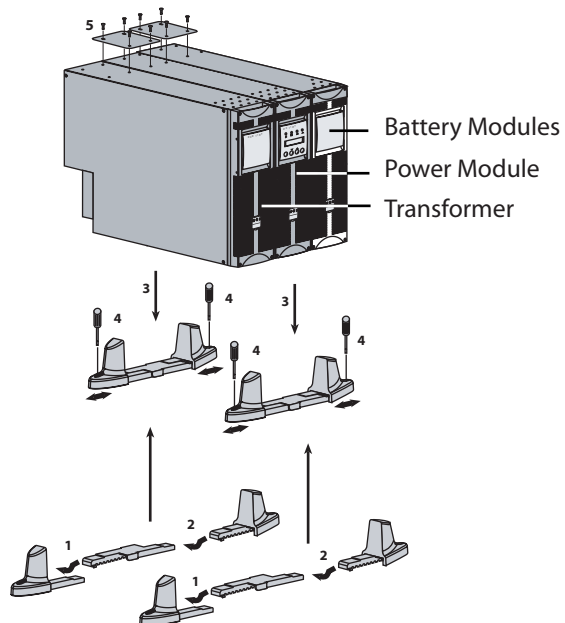

Battery Modules

Power Module

Transformer

**STEP 3 Rack Configuration (Requires optional Rail Kits 86001, 86002)**

See System Installation and User Manual for details.

**A. Prepare the power module front panel logo and LCD display for rack orientation. Apply to all modules. (Power Module shown.)**

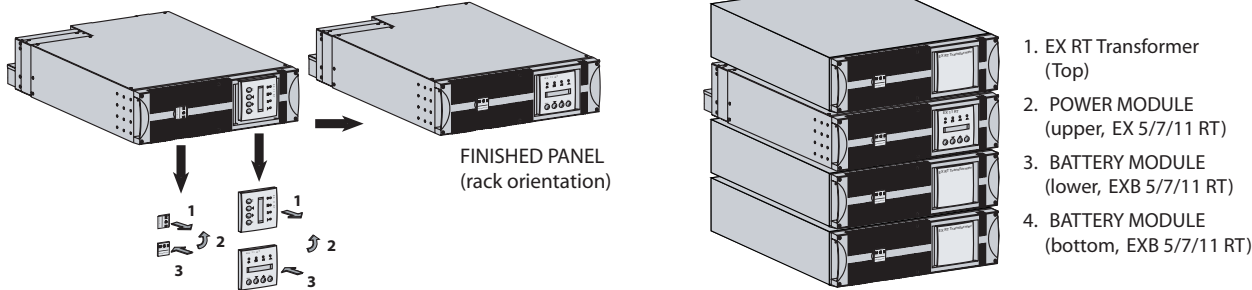

**Stack-up sequence in Rack configuration**

1. EX RT Transformer (Top)
2. POWER MODULE (upper, EX 5/7/11 RT)
3. BATTERY MODULE (lower, EXB 5/7/11 RT)
4. BATTERY MODULE (bottom, EXB 5/7/11 RT)

(Shown with power module and 2 battery modules)

**B. Rack Installation**

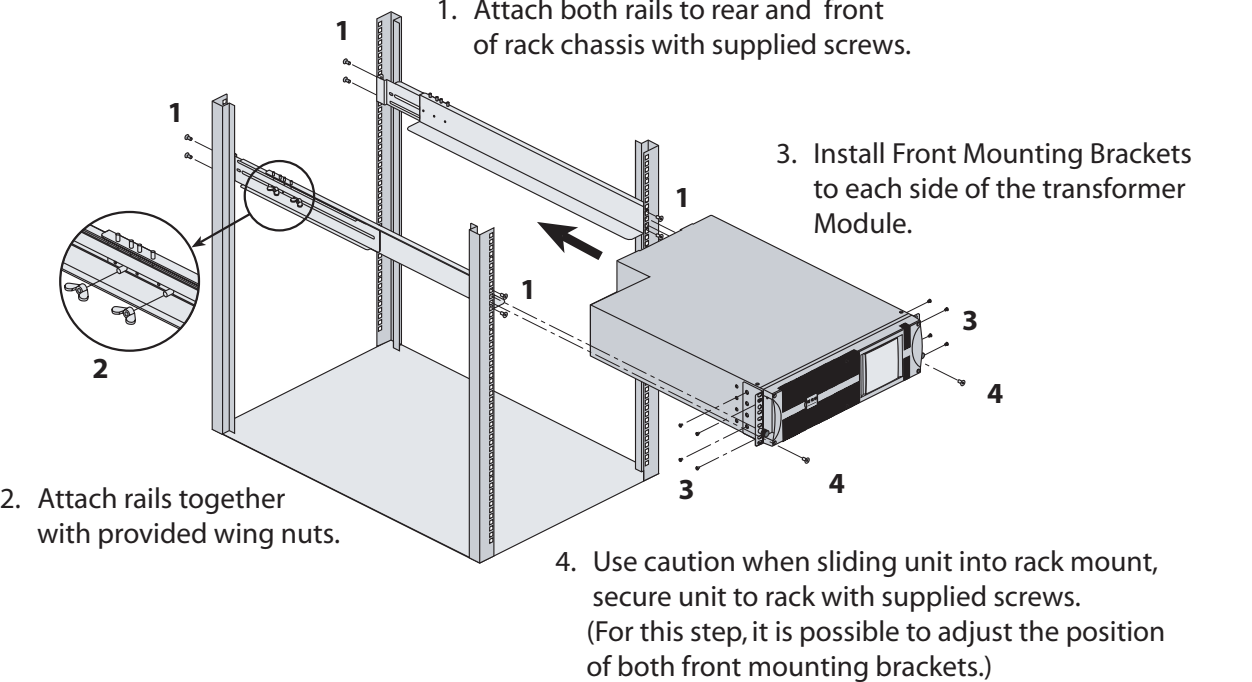

1. Attach both rails to rear and front of rack chassis with supplied screws.
2. Attach rails together with provided wing nuts.
3. Install Front Mounting Brackets to each side of the transformer Module.
4. Use caution when sliding unit into rack mount, secure unit to rack with supplied screws. (For this step, it is possible to adjust the position of both front mounting brackets.)

STEP 4 Systems Connections

EX RT Transformer, Power Module and Battery Module Connections

**A. System Connections with Transformer**

1. Check that the battery circuit breaker is OFF ("0") position.
2. Connect the battery power cable to the connectors of the power and battery modules,
3. Connect the battery detection cable between connectors of the power and battery modules.
4. Turn on battery module circuit breaker, power module circuit breaker and XFMR Main Output Circuit Breaker.

**Connection Diagram**  
(bottom of Transformer I/O Box)

⏚	L3	L2	L1	⏚	Lb	Ld	N	Lc	La
└─ 208Vac ─┘			└─ 120Vac ─┘			└─ 120Vac ─┘			
└─ 240Vac ─┘				└─ 208Vac ─┘			└─ 240Vac ─┘		
└─ AC Input ─┘				└─ AC Output ─┘					

Transformer Module Terminal block capacity: maximum 4 AWG solid or stranded wire on transformer module.

(\*) Input/Output Box Terminal Block capacity: maximum 4 AWG, 6 AWG solid or stranded wire on EX 11RT, and EX 5/7 RT respectively.

See System Installation and User Manual for initial start-up procedures.



## **Contact MGE**

### **United States**

#### **MGE UPS SYSTEMS**

1660 Scenic Ave.  
Costa Mesa, CA 92626

Tel: (714) 557-1636  
(800) 523-0142  
Fax: (714) 557-9788  
email: [info@mgeups.com](mailto:info@mgeups.com)  
www: [mgeups.com](http://mgeups.com)

### **Canada**

#### **MGE UPS SYSTEMS**

#9, 2789 Thamesgate Drive  
Mississauga, ON L4T 4E8

Tel: (905) 672-0990  
(877) 672-0990  
Fax: (905) 672-7667  
email: [info@mgeups.com](mailto:info@mgeups.com)  
www: [mgeups.com](http://mgeups.com)

### **Latin America and Other International**

#### **MGE UPS SYSTEMS**

1660 Scenic Ave.  
Costa Mesa, CA 92626

Tel: (714) 513-7831  
(800) 523-0142 ext. 7831  
Fax: (714) 434-0199  
email: [info@mgeups.com](mailto:info@mgeups.com)  
www: [mgeups.com](http://mgeups.com)