

2 kVA / kW to 18 kVA / kW SINGLE PHASE

eLITE™ SERIES **MODEL ELE**

Centralized Emergency Lighting Inverters

True uninterruptible system, compatible with all existing and future lighting applications.

Meets NFPA 101, NFPA 111, NEC, IBC, and local codes.

Applications:

- Schools / Universities
- Apartment / Condo Buildings
- Security / Public Address Systems
- Indoor / Outdoor Security Lighting
- Outdoor Egress
- Arenas / Stadiums
- Subways / Mass Transit
- Parking Structures / Garages
- Hospitals / Clinics
- Office Buildings
- Malls / Shopping Centers
- Airport Terminals
- Casinos
- Restaurants
- Theaters
- Hotels / Motels
- Churches / Worship Facilities
- Prisons



UL 924
UL / cUL 1778



CONTROLLED POWER COMPANY

EMERGENCY LIGHTING REQUIREMENTS

So what is “*emergency lighting*”, and why is it necessary? The National Fire Protection Agency (NFPA) defines the minimum requirement for emergency lighting as follows: “Emergency lighting must provide initial illumination that is no less than an average of 1 footcandle (10 lux) and a minimum of 0.1 footcandle (1 lux) at any point measured along the path of egress at floor level.” International Building Code (IBC) and many local codes are even more stringent at 1 footcandle minimum, measured at any point. In layman’s terms, the way out must be clearly visible!

21st Century Legislation

National, state, and local building codes in the commercial, industrial, institutional, educational, and specialty lighting markets require reliable emergency lighting that must operate continuously for at least 90 minutes in the event of a power outage. Halls and aiseways, stairwells, parking structures, ramps, and all passageways leading to safety must be illuminated, and all changes in direction or routes that are not immediately apparent must be clearly marked.

Apart from the existing emergency lighting codes, many U.S. cities and states have adopted legislation that requires buildings with 5 or more units of occupancy to have a **centralized emergency lighting system**, where single-point operation controls a facility’s many smaller circuits, and all testing and record-keeping of the emergency power equipment is performed from one location.

The “eLITE Series, Model ELE” = Life Safety

Meeting stringent requirements in construction and performance, Controlled Power Company’s self-diagnostic, self-testing, “**eLITE Series, Model ELE**” **centralized emergency lighting inverters** are UL 924 listed as “Emergency Lighting Equipment” and “Auxiliary Power Supplies”, as well as NFPA compliant as “Life Safety Equipment”.

The “**ELE**” offers more security and versatility to meet illumination requirements, and is the perfect complement for all life safety and lighting applications — “the universal solution”.



Proven Technology

The sophisticated commercial, industrial, institutional, educational, and specialty lighting systems of the 21st century require stable electrical power provided by a true seamless, uninterruptible, IGBT-processed, inverter with magnetic filtering. For three (3) decades, Controlled Power Company’s technology has proven itself as the cornerstone of inverter dependability and performance. Our inverter technology effectively maintains critical equipment with extended brownout protection, tight voltage regulation, and power conditioning. Tight voltage regulation assures that facility egress lumens are maintained 100% at emergency lighting fixtures, in all modes of operation, and also extends ballast and lamp life.

A properly-designed emergency lighting system meets both usage efficiency and quality factors. As a testimony of the long term performance and reliability of our inverter technology, most of our lighting inverters are still in operation to date.

Controlled Power Company’s **next generation lighting inverter** — the “**eLITE Series, Model ELE**” — is fully-compatible with all lighting, building security, life safety, and data control center applications. The “**ELE**” offers seamless transition to back-up power for emergency lighting systems and other safety-related equipment.

WHY THE "ELE"?

Major Advantages Of The "eLITE Series, Model ELE"

Design Flexibility

Using existing fixtures for emergency lighting and egress assures compliance with minimum illumination code requirements. Extensive combinations of input and output voltages, timed off bus with remote "command on" control, automatic battery testing, and control device override options make the "ELE" one of the most versatile and dependable lighting inverter systems in the market.

Single Point Operation / Maintenance

One central inverter controls many smaller circuits. Cost-effective, single-point operation provides a common battery pack, and enables all maintenance to be performed and records to be logged from a single location. Additional benefits include:

- Emergency egress lighting circuit integrity test.
- Quick battery replacement via circuit breaker disconnect.
- Standard internal bypass.
- Maintenance-free, standard 15-year pro-rated batteries.

Premium Power And Voltage Regulation

Maintains proper operating voltage for HID and high-pressure sodium lighting, as well as electronic ballasts, resulting in:

- Non-sacrificing spike and surge protection.
- Longer wire runs without upsizing the wire. Regulated voltage source minimizes voltage drop.
- Less-frequent replacement of ballasts and lamps.
- Facility egress lumens are maintained 100% (will not diminish) over the full 90 minutes of emergency power.

Generator-Compatible

The "ELE" is listed "UL924 Auxiliary Power Supplies", and is suitable to provide uninterrupted back-up power until a generator starts. Even with an extremely distorted input waveform, the output of the "ELE" delivers a clean sinewave, with no more than 5% harmonic distortion (or 3% any single harmonic), without switching to batteries. This feature also extends ballast and lamp life.

Reduced Utility Expense

Energy conservation continues to be a prevalent issue. The "ELE" provides several energy-saving solutions without compromising life safety requirements.

- Provides local control of life safety to reduce / eliminate unnecessary night-light circuits and "always on" lighting loads.
- Provides multiple, independent zone sensing abilities to reduce / eliminate unnecessary multiple-floor and multiple building-wing illumination.

All of these advantages result in the best reliability and net performance for your lighting system!

Voltage Regulation



Power Purification



Power is filtered and regulated 100% of the time.

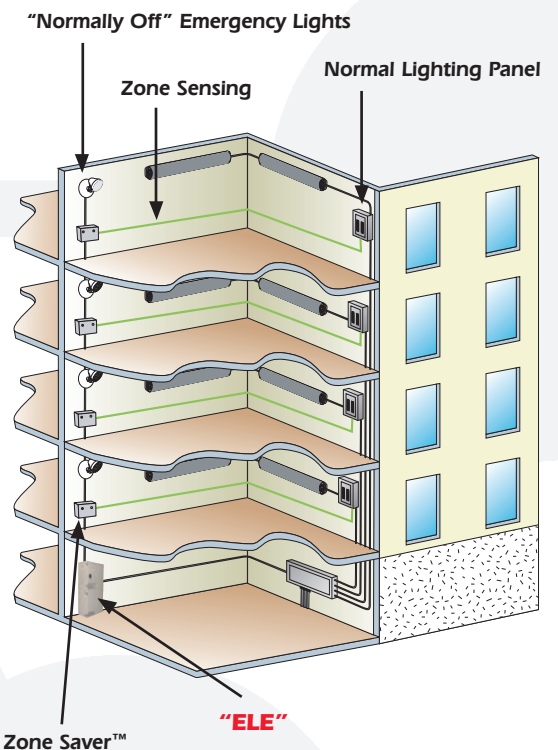

SPECIFICATIONS & OUTPUT DISTRIBUTION

Features & Benefits

The “ELE” can be used with all lighting, building security, life safety, and data control center applications.

- Uninterrupted, regulated, continuous sinewave output for use with “normally on” lighting fixtures and exit lamps.
- Standby output for use with “normally off” emergency lighting fixtures.
- Integral constant voltage transformer isolates and regulates output voltage.
- Integral status and alarm panel.
- Overload and short-circuit proof.
- Standard AC and DC input protection.
- Standard internal and optional external bypass switches.
- Advanced digital monitoring system.
- Automatic, NFPA-compliant self-testing and data logging.
- Remote communications via alarm signals, RS232, or optional fax modem.
- Integral 90-minute batteries.
- Alternate runtime capability.
- Three-stage temperature-compensated battery charger.
- Front-access design.
- Optional remote status panel and automatic phone dialer.
- Generator-compatible.

Standards

- ANSI / IEEE C62.41 Category B3
- NFPA 101
- NFPA 111 Stored Electrical Energy Emergency and Standby Power Systems. Meets SEPSS / ECE / Level 1 and Level 2 criteria for types O, U, A, B, and 10; and Classes up to and including Class 1.5
- NFPA 70 National Electric Code
- FCC Article 15, J, Class A

Safety

- UL 924 Emergency Lighting Equipment
- UL 924 Auxiliary Power Supplies
- UL / cUL 1778 Uninterruptible Power Supplies
- NFPA 101, NFPA 111, NEC, and local codes

Specifications

- Input Operating Voltage Range: +10%, -15% without battery usage
- Input Frequency: 60 Hz, +/- 2.5 Hz
- Output Sinewave Voltage: Maximum 3% harmonic distortion, any single harmonic
- Input current total harmonic distortion caused by electronic ballasts and non-linear loads: Less than 10%
- Power Factor: Self-correcting to >0.95
- Line Voltage Regulation: +/- 3%
- Load Regulation: Typically better than +/- 3%
- Isolation: Galvanic
- Standard Unit Operating Temperature: 0 deg C to +40 deg C
- Total System MTBF: 100,000 hours
- Common Mode Noise Rejection: 120 dB
- Transverse Mode Noise Rejection: 70 dB
- NEMA 1 enclosure

Batteries

- Sealed, maintenance-free, lead-calcium batteries.
- Long life, 15-year pro-rated warranty.
- Optional 20-year maintenance-free batteries and 20-year high-temperature NiCad batteries available — consult factory.

Output Distribution

- Output Circuit Breaker Pole Spaces Available:
Without Trip Indicator Alarm / Light: 20
With Trip Indicator Alarm / Light: 10
See page 8 for detailed breaker descriptions.

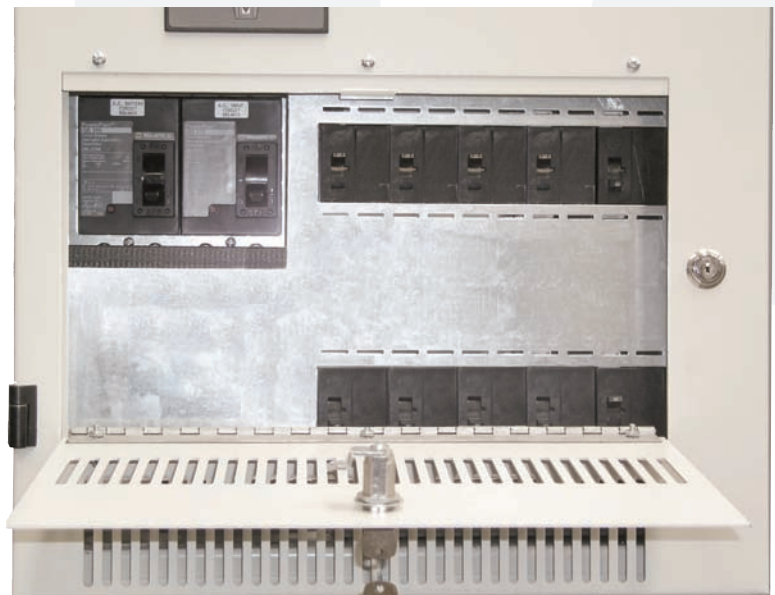

Advanced Digital Monitoring — The *Intellistat*[™]

The user-friendly *Intellistat*[™] monitor provides quick, full-access to all of the inverter's features, allows all programming to be done directly from the keypad, and provides complete system diagnostics and testing. An easy-to-read LCD indicates all the electrical parameters, as well as the functional status of the inverter. The keypad allows the entry of date / time values, system set-points, and password information into the monitor, without the need for an external computer and cable.

The *Intellistat*'s features include:

- LCD display of all electrical parameters.
- NFPA-compliant automatic battery testing / logging.
- User-programmable automatic system testing.
- System alarm annunciation.
- Audible alarm with alarm silence.
- Alarm status display.
- Programmable alarm set-points.
- Date and time display.
- Auto-logging of test results and abnormal events.
- Multi-layer password protection.
- Programmable local interfaces.
- Logs up to 50 events.
- Non-volatile clock and memory.
- Remote monitoring capabilities.
- Optional reporting of test results via fax / e-mail / voice / webpage.
- Optional status notification via e-mail / cell-phone.

Monitored Parameters

The *Intellistat* monitors the following parameters and inverter status indicators:

- Input voltage.
- Output voltage.
- Output current.
- Percent load.
- Output VA.
- Output watts.
- Output power factor.
- Output frequency.
- Battery voltage.
- Battery charger current.
- Percent battery time remaining.
- Battery temperature.

Alarms & Status

The *Intellistat* announces many alarms, including the following:

- High / low input voltage.
- High / low output voltage.
- High output VA (overload).
- *Low output VA.
- High / low output frequency.
- High / low battery voltage.
- High battery charger current.
- High battery temperature.
- General alarm.
- System on battery.
- Low battery warning.
- Low battery shutdown.
- Inverter over-temp shutdown.
- DC charger fail / DC open.
- Output circuit breaker open.
- REPO shutdown.
- System in manual bypass.

*User-programmable limit referenced during automatic battery testing, to verify integrity of egress lighting.

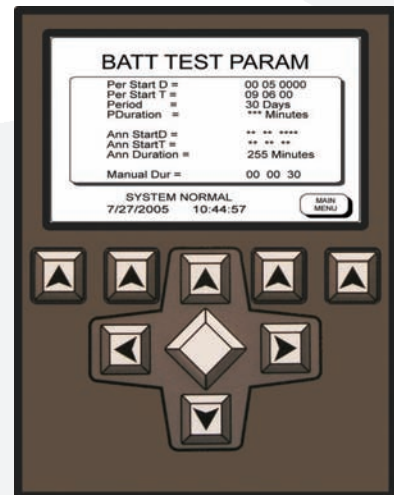

The LCD display on the model "ELE" *Intellistat* provides all electrical parameters, inverter status, programmable inverter and battery testing, remote monitoring and reporting, and data logging. An optional integrated fax modem can be included in the closed-loop communications system.

Egress Lighting Integrity Test

This standard "ELE" feature provides the industry's most advanced life safety system test available. The *Intellistat* automatically energizes all life safety circuits, regardless of egress lighting design ("always on", "normally off", local control device switch position, or zone sensing) during the required monthly and annual tests. The *Intellistat* then compares power consumption during the test period with user-defined load capacity, analyzes the data, and advises if service is required.

Automatic System Tests

The *Intellistat* automatically performs a user-defined (date and time) 5-minute system test every 30 or 90 days; as well as user-defined (date and time) annual 30-, 60-, or 90-minute system tests. For all of these tests, the *Intellistat* logs the test results with date and time, as well as a "pass" or "fail" indication.

Manual System Tests

The *Intellistat* also allows the user to manually invoke a user-defined system test for 30-, 60-, or 90-minutes. A 1-minute or 5-minute manual test is also available for "spot inspections".

DESIGN FLEXIBILITIES & PROVEN SOLUTIONS

The “ELE” offers design flexibilities which are not provided with competing lighting inverters:

Multi-Voltage Capabilities (Figure 1)

The “ELE” is designed to supply multiple, pre-wired voltages at the same time, with no inverter system modifications or additional transformers. The “ELE” provides voltage flexibility using a standard, internal, multi-tap, power conditioning, constant voltage transformer. The front-mounted terminal blocks ensure a clean, simple installation.

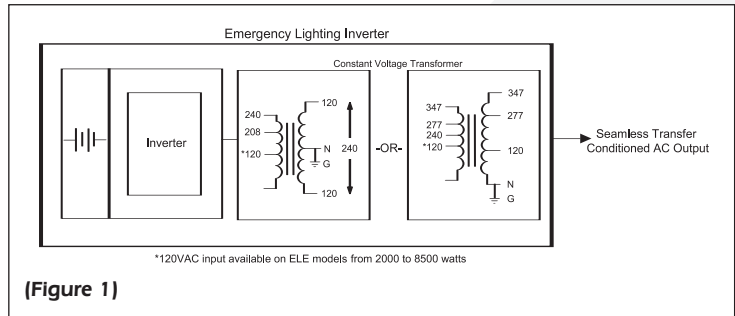

(Figure 1)

UL 924A Auxiliary Power Supply (Figure 2)

(Figure 2)

The “ELE” is recognized by UL 924 as an Auxiliary Power Supply for Emergency Lighting, commonly known as UL 924A. This additional UL effort and certification provides the perfect complement to generator-based emergency lighting systems. The “ELE” provides uninterruptible, regulated power to critical lighting systems and other life safety related equipment. Additionally, for uncompromised personal safety, critical “always on” lights remain illuminated, and the generator synchronization delay is eliminated.

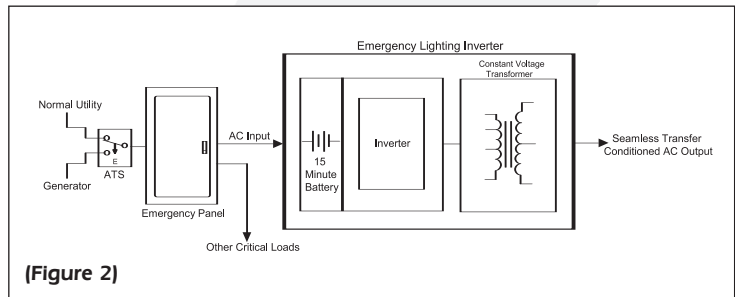

(Figure 2)

Remote Input Command (Figure 3)

Allows the monitoring of multiple locations and events within the emergency lighting system, and may be activated by a signal from any specified monitoring point. If an unacceptable condition exists at one or more of the locations being monitored, the open contact energizes the “Normally Off” bus, thus illuminating the “Normally Off” emergency lights. Likewise, when normal conditions are restored, the “Normally Off” bus is de-energized, and the emergency lights return to their “Normally Off” state.

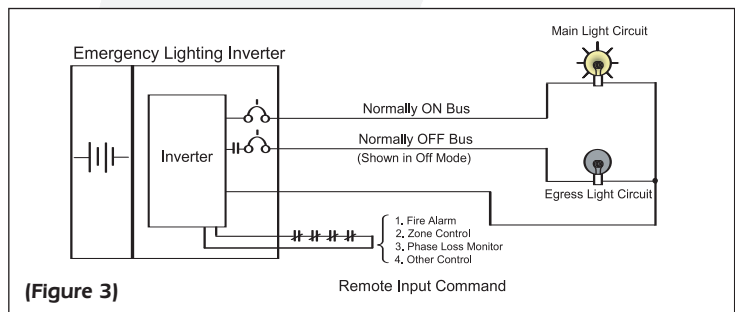

(Figure 3)

Local Control Device Override (Figure 4)

(Figure 4)

The “ELE” allows for user control of emergency egress lighting. This includes (but is not limited to) occupancy sensors, wall switches, and dimmer switches. Not only is this approach more reliable, it also saves money because it reduces costly “always on” circuits.

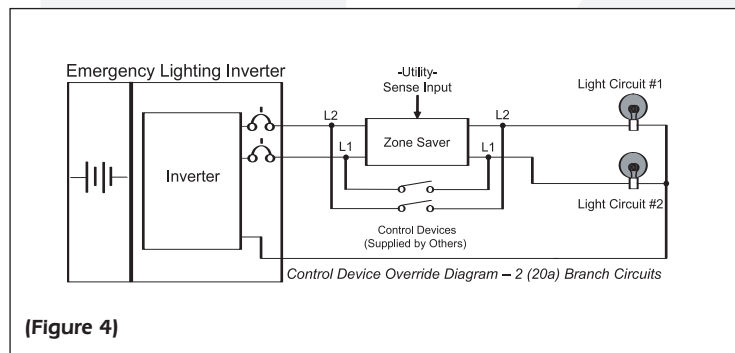

(Figure 4)

Zone Sensing (Figure 5)

The most cost-effective emergency lighting applications allow for independent activation of “Normally Off” fixtures in multi-floor or multi-use facilities. The “ELE” uses ZoneSaver™ to monitor normal lighting circuit panels for each floor / zone. Failure of the normal lighting circuit panel activates the emergency lighting for that floor / zone only.

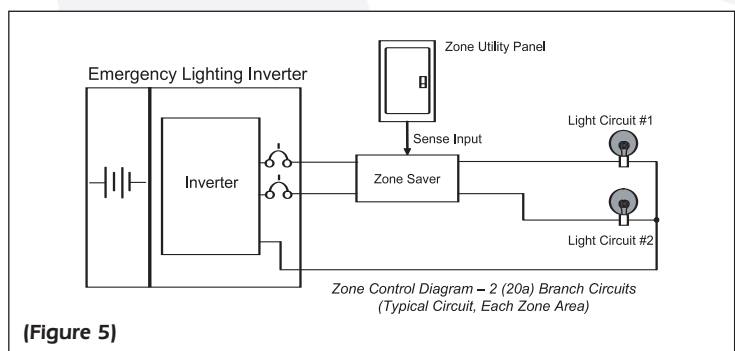

(Figure 5)

INVERTER OPTIONS & CABINET CONFIGURATIONS

The "ELE" offers a variety of special options:

Normally Off Bus

Provides standby power to "normally off" emergency lamps, at the same or different voltage than "normally on" emergency lamps. When utility power is lost or voltage is inadequate, emergency power is supplied to "normally off" lights, providing a safe means of egress.

Timed Normally Off Bus

Functions the same as the **Normally Off Bus** (above), but differs in that the "Transfer ON" and "Return OFF" times for the bus are programmable. This programmable feature is especially useful to prevent nuisance activation of emergency lighting during short-term power disturbances. Additionally, the return delay provides sufficient time for standard HID lighting recovery, factory-set at 15 minutes.

Automatic Phone Dialer

Plugs into the communications port of the inverter, and can be programmed to notify personnel of alarm conditions. This small device can dial up to four (4) phone numbers (land, cell, pager); and records and delivers a custom voice message.

Multi-function Communications Modem

Automatically and immediately files and reports the inverter's battery test results via fax, e-mail, numeric page, voice message, or webpage.

Output Distribution Circuit Breakers

Meeting the need for flexible power distribution, circuit breakers can be added, subtracted, or moved without any complex mounting techniques. Output circuit breakers can be configured to supply power to different lighting loads at different voltages. Front-access to the standard input breaker and the optional output distribution circuit breakers is through a lockable drop-down panel door.

Lighting Inverter Communications

Optional software communications packages enable the user to monitor the inverter on a network, or enable the inverter to become a node on the network. The inverter's status and alarm conditions can be viewed via a web browser or a network management station. Additional communications features include: SNMP / TCP / IP capability, date / timestamp event logging, and alarm notification.

Modular Battery Cabinets

Standard, 15-year pro-rated batteries are included with the user-friendly, modular battery cabinets. The "ELE" battery cabinets have a compact, space-saving "footprint", and easy-access lift-off doors to accelerate inverter installation and minimize battery replacement procedures. The stackable, modular cabinets are easily-configured to accommodate even the most confining floorspace requirements. Within the cabinets, the unique shelving configurations increase accessibility for battery maintenance or replacement. The illustrations below assume unity power factor and 90 minutes runtime. Consult factory for cabinet configurations using alternate runtimes.

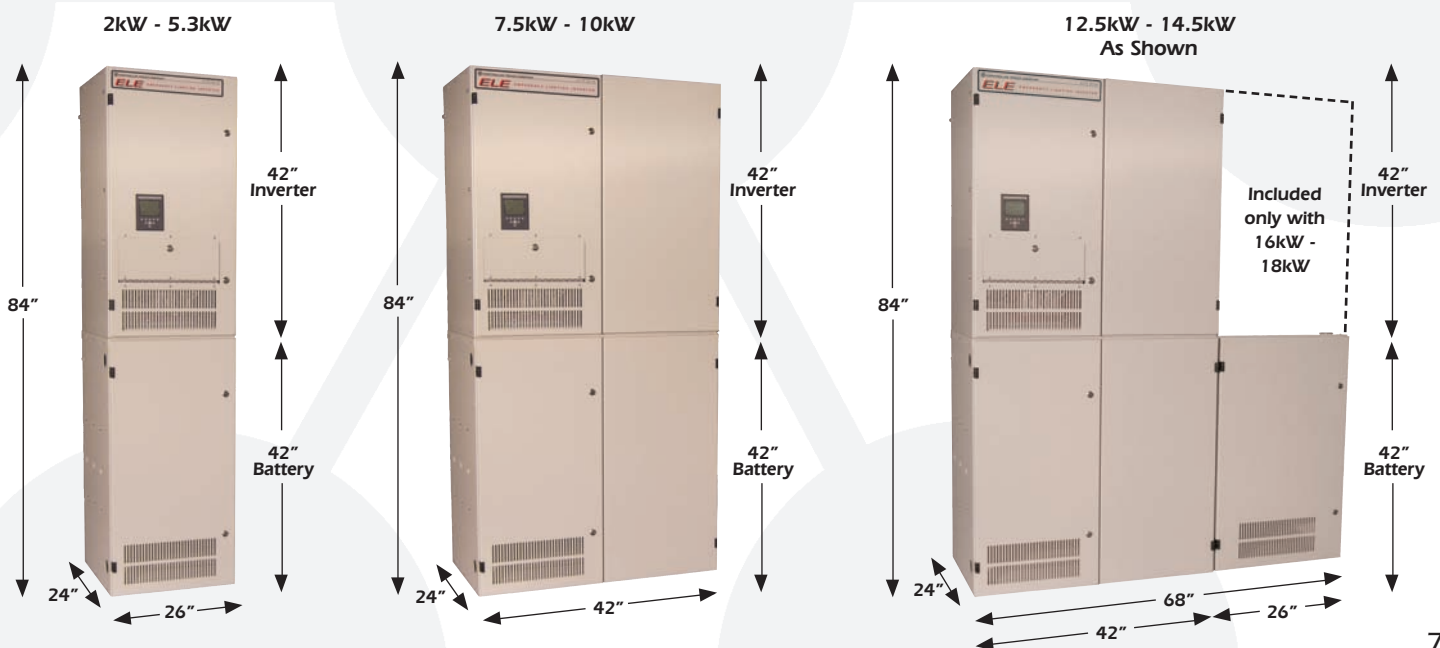

PRODUCT SELECTION GUIDE

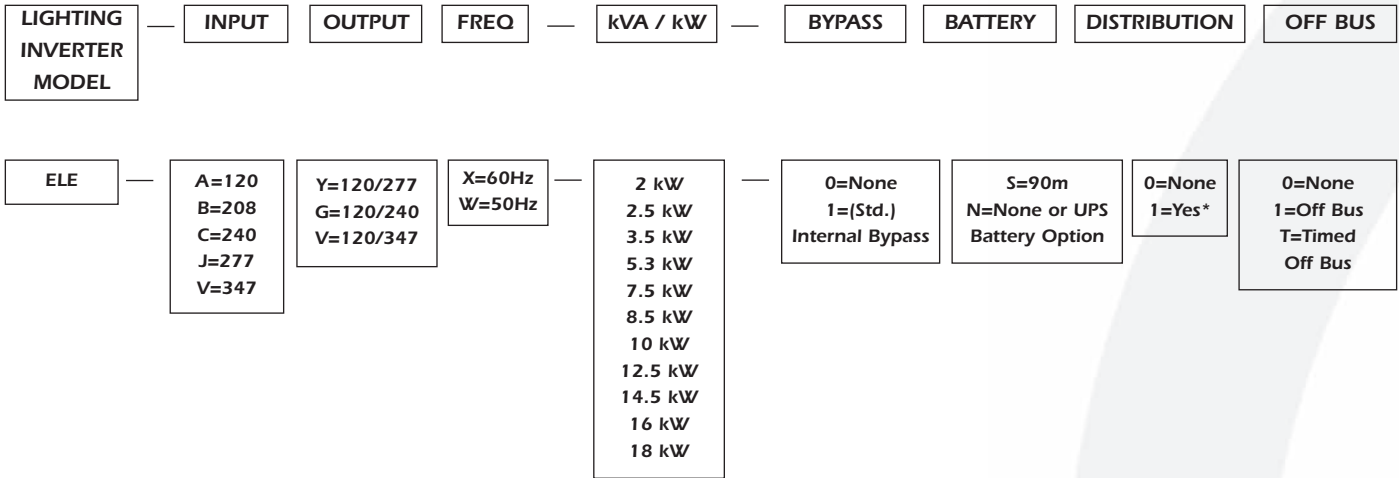

Example: ELE-AYX-2KW-1S01

2 kW inverter, which has 120 input, 120/277 output, 60 Hz, internal bypass, 90 minute battery, no distribution, and an off bus.

Model "ELE" Notes:

- * Standard distribution breaker options include: 1 pole, 15 A or 20 A, 120 VAC or 277 VAC.
2 pole, 15 A or 20 A, 208 VAC or 240 VAC.
Other breaker amperage ratings are available — consult factory.
- Maximum output circuit breaker pole spaces available: Without trip indicator alarm / light = 20
With trip indicator alarm / light = 10
- Specify circuit breaker quantity and ratings when ordering.

Each model includes 90 minutes back-up time, per UL 924 Emergency Lighting Equipment. Battery runtimes other than 90 minutes are available under UL 924 Auxiliary Power Supplies — consult factory.

Input/Bypass isolation transformer available for 480 VAC and 600 VAC applications.

84"H x 26"W x 24"D	84"H x 42"W x 24"D	84"H x 68"W x 24"D
2 kW — 1054 lbs.	7.5 kW — 2192 lbs.	12.5 kW — 3505 lbs.
2.5 kW — 1054 lbs.	8.5 kW — 2736 lbs.	14.5 kW — 3772 lbs.
3.5 kW — 1162 lbs.	10 kW — 2956 lbs.	16 kW — 4374 lbs.
5.3 kW — 1571 lbs.		18 kW — 4528 lbs.

Weight includes inverter and batteries for standard 90 minutes runtime. Battery weights vary according to desired runtimes.

Standard, 15-year pro-rated batteries for the model "ELE" are included with the user-friendly, modular battery cabinets. See page 7 for additional details.



1955 Stephenson Hwy. Troy MI 48083
 www.controlledpwr.com
 email: info@controlledpwr.com
 Phone: (248) 528-3700 Fax: (248) 528-0411
 Call Toll Free: (800) 521-4792

Represented by:

