



COOLING FOR CRITICAL ELECTRONICS

CoolCube 12

12,000 BTU/H Model

USER & INSTALLATION MANUAL

TABLE OF CONTENTS

GENERAL DESCRIPTION	4
TECHNICAL SPECIFICATIONS.....	5
UNIT DESCRIPTION.....	6
Standard Features.....	6
Applications.....	7
Electrical.....	8
Condensate	9
Installation	10
Installation—Hanging Applications.....	11
Installation—Permanently Connected.....	12
Installation—Stacking Kit	13
Installation—Rack Mounting Kit	14
Accessories.....	15
Deluxe Electronic Controller	20
SERVICE	23
Troubleshooting Guide	23
Replacement Parts Procedure	24
Preventive Maintenance.....	25
Piping Schematic.....	26
Wiring Diagram	27

FORWARD

This manual provides the user with basic details for the installation and operation of the CoolCube 12 spot cooler. It is recommended to read and fully understand the instructions outlined within this manual, before operating the unit.

As with all commercial air conditioning equipment, it is recommended to have the CoolCube 12 sized and installed by a licensed specifying engineer and contractor, in accordance with all local and state codes. The length of service received can be extended by following the installation and preventive maintenance instructions.

NOTICE

In our ongoing process of continuous improvement, the items and procedures described in this manual are subject to change without notice. Please note model and serial number of the CoolCube 12 when contacting the factory.

GENERAL DESCRIPTION

The CoolCube 12 is a portable air-cooled spot cooler designed for permanent or temporary spot cooling. The entire air conditioning unit has been built in an premium sheet metal cabinet, equipped with heavy-duty casters for mobility. The CoolCube 12 can be operated as a stand-alone spot cooler, or can be permanently installed in a server rack, or above a drop ceiling. Equipped with a 10-foot power cord for electrical connection and added mobility in service.

This spot-cooler is designed to direct air to specific areas or objects through a discharge grill located on the upper-front of the unit, while rejecting heat from the back of the unit. The CoolCube 12 is a self-contained unit with the entire cooling system, evaporator and condenser fan motors and electrical components neatly arranged in a black polyester powder coated metal cabinet. When connected to the proper source of electrical power, the unit is controlled by a solid-state electronic controller, with numerous options of temperature and airflow controls that will provide the desired level of comfort and cooling.

A wide variety of accessories and factory installed options are available for the CoolCube 12 allowing for improved performance and added versatility.

WARRANTY CARD

It is important that the warranty card be filled out completely and returned to the factory within fourteen (14) days of installation of the unit in order to receive the benefits of the warranty.

TECHNICAL SPECIFICATIONS

MODEL: **CoolCube 12**

COOLING CAPACITY	12,000 BTUH
VOLTAGE	115 V
COOLING AMPS	12.0 A
MAX FUSE SIZE	15 A
COOLING WATTS	1180 W
IN RUSH AMPS	63 A
EER	10.0
COMPRESSOR TYPE	ROTARY
COMPRESSOR MOTOR	1 HP
COMPRESSOR RLA	9.5 A
COMPRESSOR LRA	50 A
EVAPORATOR BLOWER	CENTRIFUGAL
EVAP CFM - HIGH	400 CFM
EVAP CFM - LOW	320 CFM
EVAP MOTOR AMPS	1.7 A
EVAP MOTOR WATTS	130 W
CONDENSER BLOWER	CENTRIFUGAL
COND CFM	490 CFM
COND MOTOR AMPS	1.4 A
COND MOTOR WATTS	150 W
POWER CORD	14/3
PLUG TYPE	5-15 P
CORD LENGTH	10 FT
LCDI	INCLUDED
CONDENSATE RESERVOIR	REMOVABLE TANK
CAPACITY	2 GALLON
REFRIGERANT	R-410A
CHARGE	18 OZ.
HEIGHT WITH CASTERS	24 in.
HEIGHT WITHOUT CASTERS	20 in.
WIDTH	17-1/4 in.
DEPTH	24 in.
NET WEIGHT	130 lb.
SHIPPING WEIGHT	160 lb.
SHIPPING VOLUME	14 cu. ft.

UNIT DESCRIPTION

Standard Features

CABINET

The CoolCube 12 spot cooler has a cabinet that is constructed of 18 gauge steel with a polyester powder coated finish. The matte black finish compliments any surrounding space, and the cabinet is lined with sound-absorbing insulation for cool, quiet comfort. The CoolCube 12 comes equipped with handles and premium swivel casters for portability and convenient set-up.

DELUXE ELECTRONIC CONTROLLER

The CoolCube 12 unit is equipped with deluxe electronic controller. When power is connected to the unit, the thermostat will control the unit to cool a space to the desired temperature. The thermostat is also capable of controlling the fan to operate automatically (when needed) or continuously.

AUTO RESTART (FEATURE)

The controller has auto-restart capability. A built-in memory retains the settings, and the unit will restart to the last set point automatically, after a power failure.

FAN SPEED CONTROL

One of the features of the electronic controller is that the unit supply fan can be controlled automatically or manually. In AUTO mode, the evaporator blower will adjust air flow automatically for added comfort and performance. Or if desired, the fan speed can be set to MANUAL mode and the evaporator blower will run continuously at one of six levels of fan speed.

CONDENSATE RESERVOIR/TANK

The CoolCube 12 unit comes equipped with a Condensate Reservoir Tank for handling the condensate generated during the cooling process. When the tank is full, the word CON will be displayed. The tank can be easily removed from the unit and emptied as required.

FILTERS

CoolCube 12 are equipped with washable filters at the air intakes. Electrostatic mesh air filters located behind the evaporator return air grill serve to filter the air before it is cooled, and behind the condenser return air grill to prevent dust build-up. Both filters can be easily removed and cleaned.

HIGH PRESSURE SAFETY SWITCH

Located on the back of the CoolCube 12 is a manual re-set high pressure switch, used for the protection of the compressor. If the condensing pressure exceeds the limit setting, the cut-out shuts down the compressor, while the evaporator fan remains running. The display will indicate CON. The compressor can be re-started, once the condensing pressure has lowered, by depressing the "RESET" button.

POWER CORDS

CoolCube 12 units come with a 10 ft. power cord, allowing for convenient connection and portability. The power cord is equipped with a Leakage Current Detection Interrupt (LCDI) device for added safety.

Applications

SPOT COOLER

The CoolCube 12 can be used in an open environment to cool specific objects or "spots". Spot Cooling is a convenient and economical way to provide air conditioning where cooling the entire space is impractical. Cool air is discharged from the unit and is directed where it is needed. Nozzle kits can be used to improve direction of the cooling airflow.

ROOM AIR CONDITIONER

With the condenser fully ducted, the CoolCube 12 can be used as a room air conditioner to cool an enclosed space. Using the condenser return air panel (CP-8) and ceiling discharge kit (CK-8), the CoolCube 12 can operate as a room air conditioner with the condenser air isolated from the conditioned space.

CEILING MOUNT

The CoolCube 12 can be hung above a space or be installed above a drop ceiling allowing the unit to cool a room or area without taking up any valuable floor space.

RACK MOUNT

The CoolCube 12 can be rack mounted inside a 19-inch computer rack, occupying just 12U of rack space.

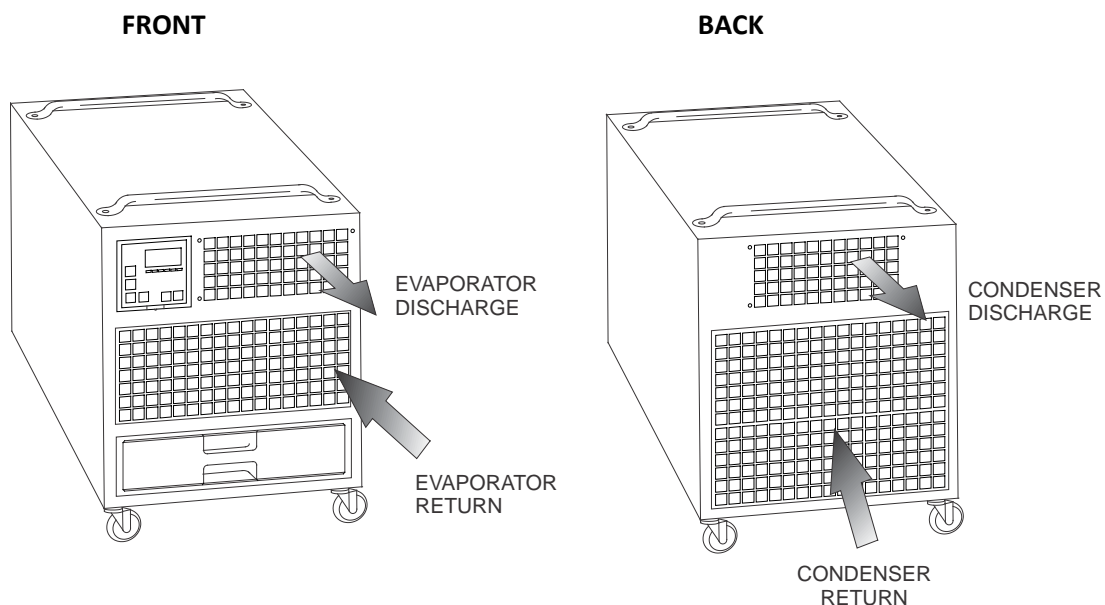

Electrical

PORTABLE CONFIGURATION

The CoolCube 12 is equipped with a 10 ft. power cord for ease of movement and portability. The cord is to be plugged into a 15 Amp receptacle. A dedicated circuit is required.

MODEL	PLUG CONFIGURATION	RECEPTACLE
- CAC1211	 15A-125 VOLT NEMA 5-15P	NEMA-5-15R

SERVICE CORD

The CoolCube 12 is equipped with a ten foot long service cord with LCDI (Leakage Current Detection & Interruption) device that serve as a means of electrical protection.

DO NOT USE THE LCDI AS AN ON/OFF SWITCH FOR THE UNIT

A DAMAGED LCDI POWER SUPPLY CORD MUST BE REPLACED WITH A NEW POWER SUPPLY CORD AND NOT REPAIRED

USE OF EXTENSION CORDS

CAUTION: AN EXTENSION CORD CAN BE USED PROVIDED IT IS RATED AT LEAST 15 AMPS @ 115 VOLTS WITH GROUNDING-TYPE ATTACHMENT PLUG AND GROUNDING TYPE CONNECTOR (LOAD FITTING)

PERMANENT INSTALLATION

The CoolCube 12 can be installed in a permanent configuration, and the control box is suitable for field wiring. The unit can be hung from 5/16" threaded rods, or be installed with the use of UniStrut.

Instructions for Permanent installations are on Pages 8 and 9 in the manual.

When hanging and permanently connecting the CoolCube 12, all applicable local/state/federal building codes must be followed.

The structural beam(s) must be capable of properly supporting the weight of the unit (135 lbs.)

Condensate

CONDENSATE RESERVOIR TANK

The CoolCube 12 has a 2-gallon polyethylene tank for collecting condensate. The tank is located in the lower, front section of the unit. A high water level cut-out switch is used to stop the compressor and condenser fan automatically when the tank's pre-set water level has been reached. The evaporator fan will continue to run, circulating air.

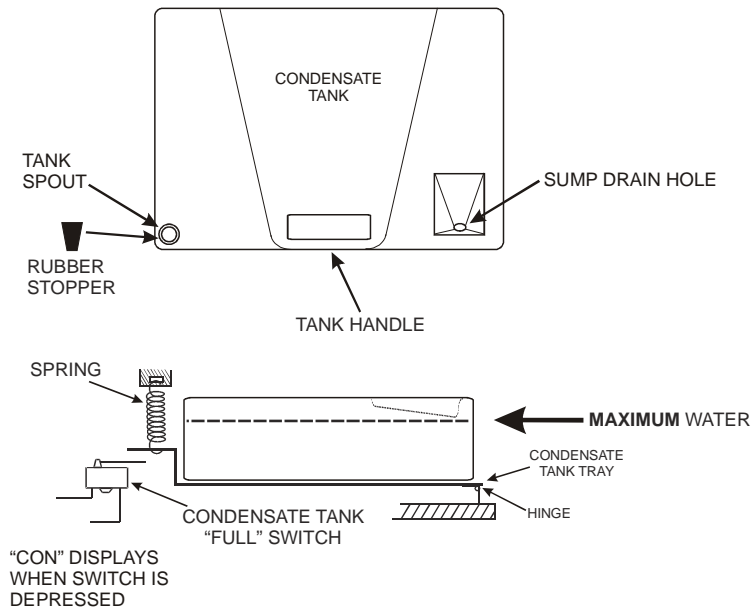

EMPTYING THE CONDENSATE RESERVOIR TANK

In the COOL Mode, condensate will accumulate in the condensate tank. When the tank becomes full, the Deluxe Control will shut down the compressor and the word CON will be displayed along with the room temperature. To empty the tank, do the following:

1. Press the POWER button, to turn the unit off
2. Pull the tank from the lower front of the unit, using the handle.
3. Remove the rubber stopper and empty the tank in a nearby sink.
4. Replace the rubber stopper.
5. Place the tank back in to the unit, making sure the tank is in correctly.
6. Press the POWER button to re-start the unit.

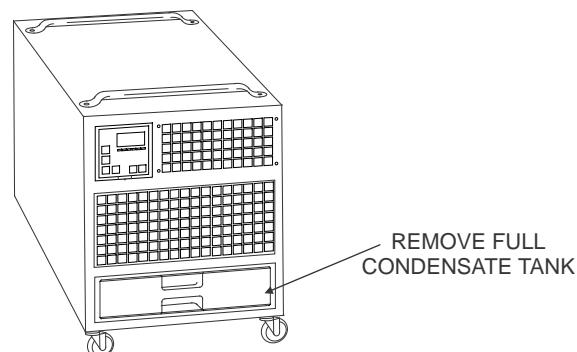

Installation

Receiving—Inspection:

Upon receiving your CoolCube 12, inspect the packaging for any damage. All units are shipped on a skid, and packaged in a triple-wall carton for added protection. In shipment, some wear may occur on the packaging. If the packaging is heavily damaged or broken, file a claim with the freight company immediately. Carefully unpack the unit and remove all wrapping materials. Save all documentation and fill out the Warranty Card and mail it to Xtreme Power.

Before Installing

Check the CoolCube 12 for any damage. All Xtreme Power products are thoroughly inspected at the factory and carefully packaged. If any damage is evident, file a claim with the delivering carrier immediately.

Electrical Requirements

Check the nameplate located on the back of the unit to make certain that the proper power is available for the unit. Refer to "Specifications" section for voltage and amperage requirements. For proper NEMA receptacles, refer to "Electrical service plug configuration". When using extension cords, use the properly sized cord, and check cord voltage to the unit. TIME DELAY FUSES/CIRCUIT BREAKERS ARE RECOMMENDED

WARNING—Operating the unit on improper voltage will void the warranty

Accessories

Verify that all accessories are correct for the model, and that they installed in accordance with all instructions.

Start-Up

Install the unit in accordance with all local and state building codes, and install all accessories. Allow for a clearance around the unit for future maintenance and/or service. Level unit and lock casters, when available. Connect power and test the LCDI on the power cord (if available). Power up unit, via thermostat and check for proper operation. Refer to Thermostat Operation for more details.

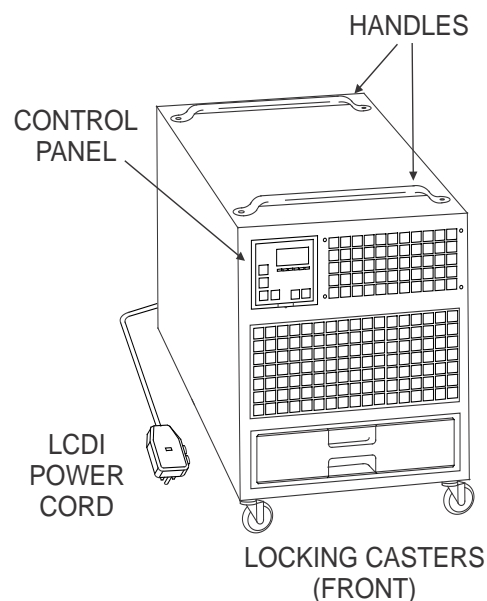

Installation—Hanging Application

The CoolCube 12 may be installed above a space or above a drop ceiling, as required. The unit can be hung from a building's structural beam by one of three means:

- Using 5/16" -18 threaded rods secured into the top of the unit at the 4 corners. Make sure there is a minimum of 1/2" thread engagement into panel nuts. Rods are to be secured to upper structure by means of washers and nuts.
- Using 12 ga. Uni-Strut (P1000 Series or equivalent) secured to the top of the unit by 5/16-18 bolts
- Using 12 ga. Uni-Strut (P1000 Series or equivalent) secured beneath the unit by 5/16-18 bolts

When hanging or permanently connecting the CoolCube 12, it is advised that you remove the unit casters and handles prior to installation.

CAUTION - When hanging or permanently connecting the CoolCube 12, all applicable local/state/federal building codes must be followed. The structural beam(s) must be capable of properly supporting the weight of the unit (130 lbs.)

WHEN INSTALLED—UNIT IS TO BE PLUMB AND LEVEL

**INSTALL (4) 5/16-18
THREADED RODS INTO
TOP PANEL OF UNIT**

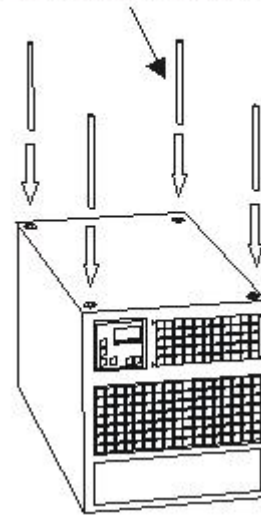

UNI-STRUT INSTALLATION

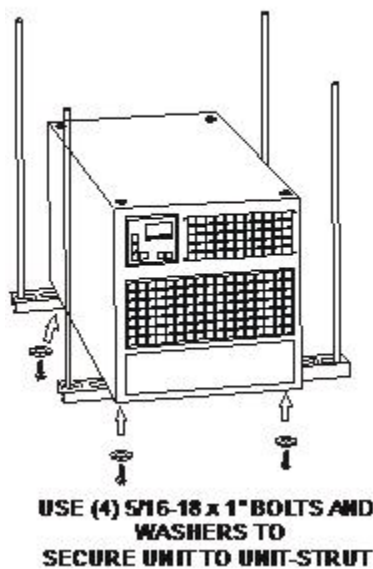

**USE (4) 5/16-18 x 1" BOLTS AND
WASHERS TO
SECURE UNIT TO UNIT-STRUT**

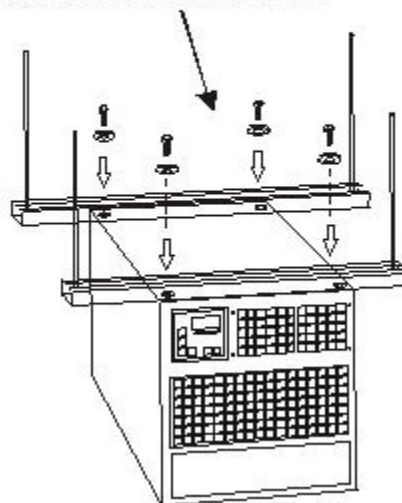

Installation—Permanently Connected

The CoolCube 12 power cord may be removed and the unit be permanently connected to a power source for applications where desired. Once the CoolCube 12 is installed and secured for a stationary installation, the unit can be permanently wired.

1. Remove the left side panel and locate the power cord and strain relief at the rear of the Unit.
2. Disconnect the power cord from the ground lug and terminal strip.
3. Remove the power cord and the strain relief.
4. Install 1/2" conduit and a UL recognized bushing through the 7/8" diameter hole, CONDUIT PORT, and secure.
5. Three (3) conductors, a minimum of 14 AWG, are required for LINE, COMMON and GROUND can then be connected to the unit, and then be connected to a 115 VAC, Single Phase, 60 Hz, that is rated at 15 A

USE COPPER CONDUCTORS ONLY

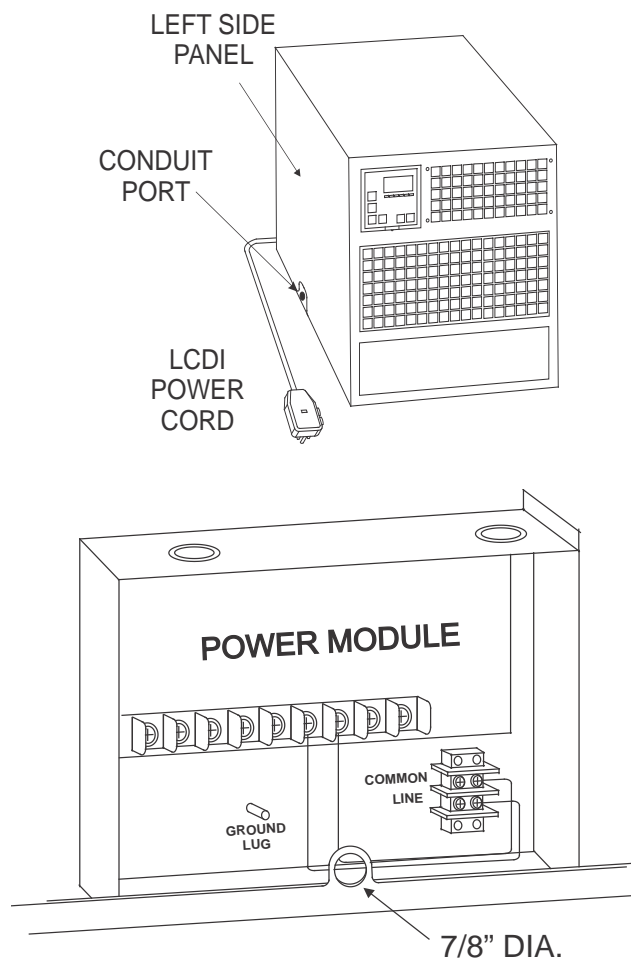

CONTROL BOX - FIELD WIRING

Installation—Stacking Kit, Sk-1

Two or three CoolCube 12 units are required when redundancy is critical, cooling large areas, or high heat loads. The CoolCube 12 can be stacked on top of each other to produce a capacity of 24,000 or 36,000 BTUH, while maintaining the same footprint. To facilitate the stacking of the CoolCube 12 units, a stacking kit, SK-1, is required for each additional unit.

Disconnect Power before Servicing

1. Remove Handles from units, and remove the casters from the unit to be stacked.
2. Install rubber feet on base of unit to be stacked
3. Carefully stack the units—each unit weights approximately 130 lb.
4. Secure the stacked unit to the one below it by using the stacking rails, provided. Install rails on both sides of units.

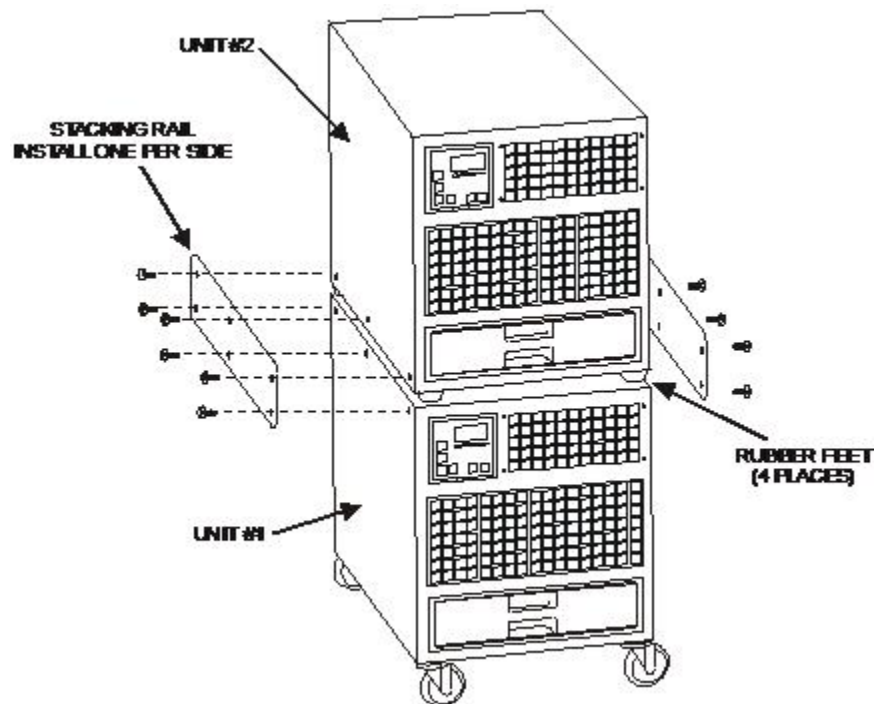

Installation—Rack Mounting Kit, Rck-1

The 19-Inch Rack Kit allows for the CoolCube 12 to be installed into any EIA-310-D 4-Post or 2-Post rack enclosure. The kit includes (2) heavy duty rails (4) side mounting brackets and a rear mounting rail. The rails have a vibration dampening foam layer secured to the top for noise reduction. The hardware included in the kit will accommodate most installations, such as Square Hole Racks, 12-24 Threaded Racks, 10-32 Threaded Racks and round hole racks.

1. Disconnect Power before Servicing
2. Remove handles and casters from the unit.
3. Install rails in rack and secure with side brackets and hardware.
4. Carefully install Cool Cube into Rack onto of rails.
5. Secure the unit to the rails by use of the rear mounting rail.

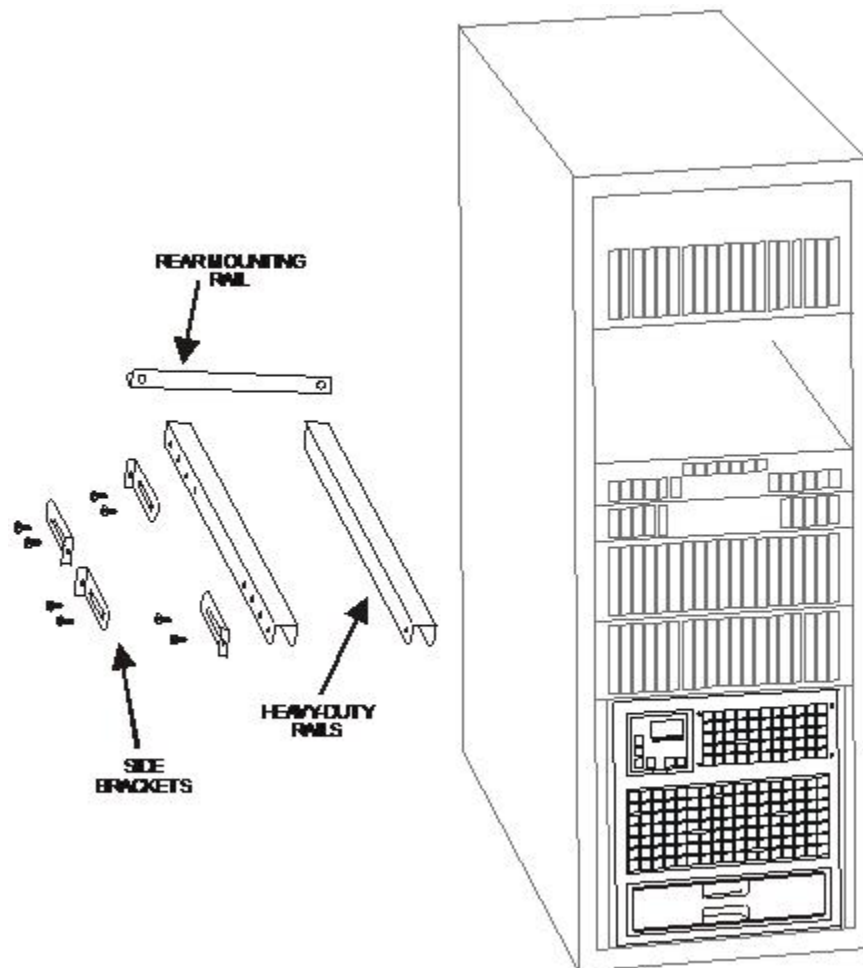

Accessories

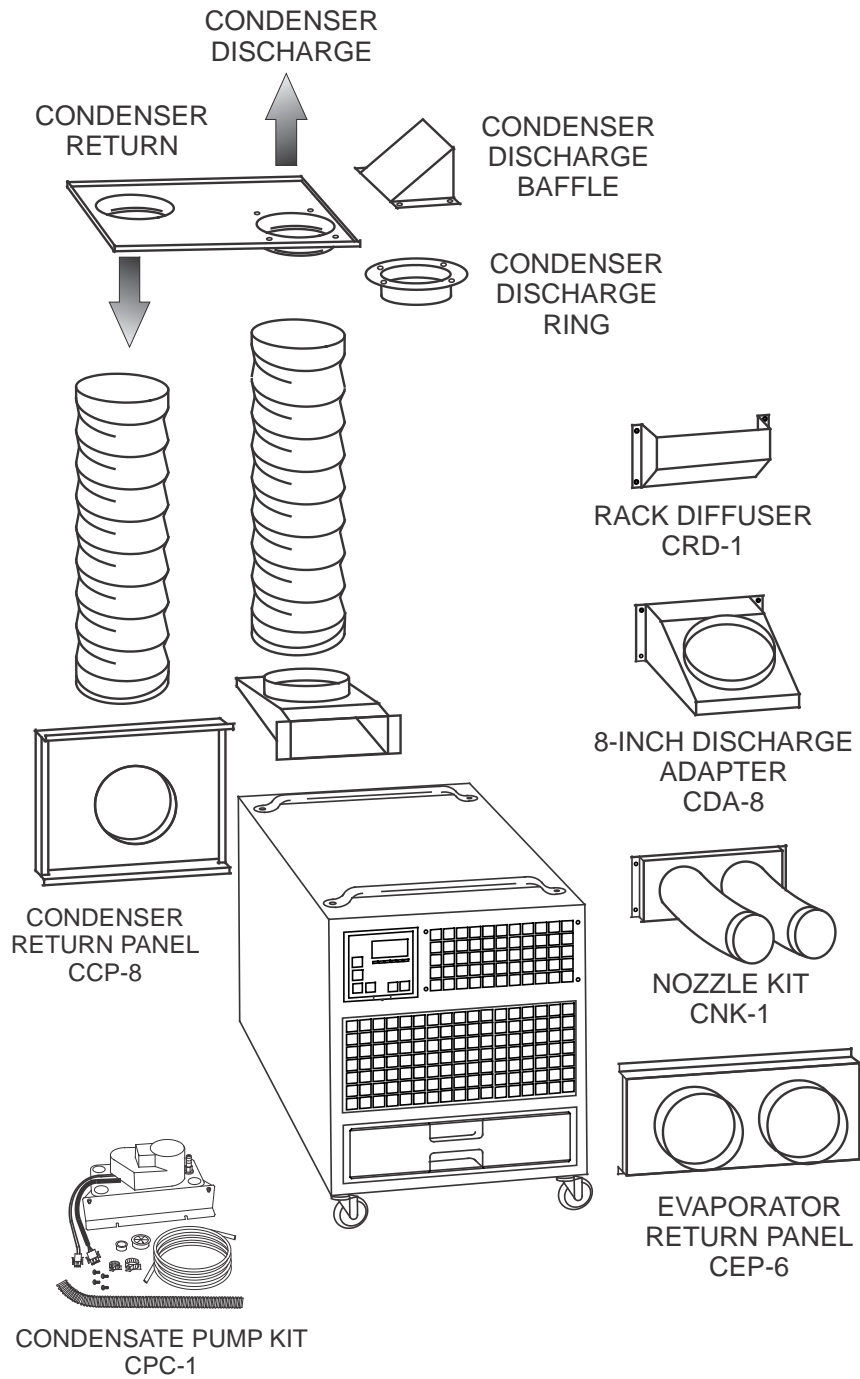

CEILING PANEL DUCT KIT, CK-8

A ceiling panel kit is available for discharging the condenser air above a drop ceiling. The ceiling panel duct kits are furnished with an 8-inch white vinyl coated flexible duct that allows for convenient installation. A 2ft X 2ft ceiling duct-panel is included to replace a 2ft X 2ft drop-ceiling panel where the connection is desired. The CK-8 ceiling panel kit consists of a 2' X 2' lay in ceiling panel with duct flange, 8-Inch vinyl coated flex-duct and the CDA-8 discharge adapter that attaches to the condenser air discharge opening on the back of the unit.

Note—Drop ceiling spaces should be vented or large enough to handle the warm condenser air. Check local codes to assure compliance.

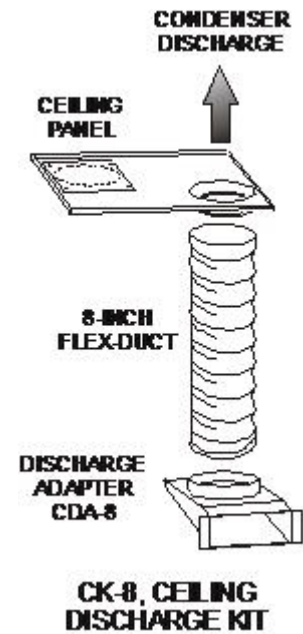
**CEILING PANEL CONVERSION KIT, CVK-8**

The CK-8 can be converted to a dual ducted ceiling panel by use of the CVK-8 conversion kit. The kit contains the parts necessary to install a second 8-Inch duct flange and a condenser discharge baffle onto the CK-8 ceiling panel. This allows for ducting of condenser air to and from the drop ceiling plenum. The kit contains an 8-inch duct flange and a discharge air baffle that can be installed onto the ceiling panel, as shown below, along with an 8-inch flex-duct. The baffle can be installed in various orientations, to direct the discharge air away from the condenser return air above the ceiling panel.

Note—Drop ceiling spaces should be vented or large enough to handle the warm condenser air. Check local codes to assure compliance.

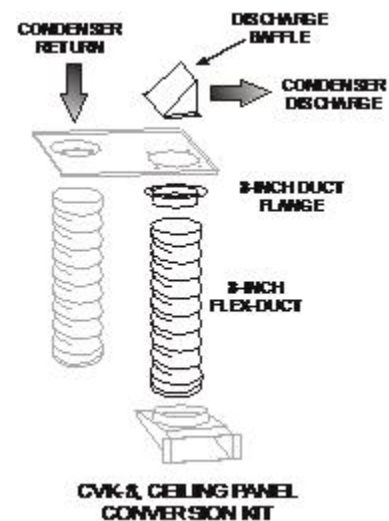

WHEN INSTALLED—THE CONDENSER DISCHARGE SHOULD BE DIRECTED AWAY FROM THE CONDENSER AIR RETURN

CONDENSATE PUMP KIT , CPC-1

The condensate pump provides for the automatic removal of condensate water during the cooling process. The pump is capable of pumping against a 20 foot head, allowing for the routing of the drain line above the drop-ceiling to a nearby drain. The pump is controlled by an internal float-switch which turns the pump on and off automatically. The pump is also equipped with a condensate over-flow safety switch, that will shut down the compressor when the pump is not working properly. The word "CON" will be displayed along with the room temperature. Kit includes the pump, mounting hardware and 24 feet of condensate hose.

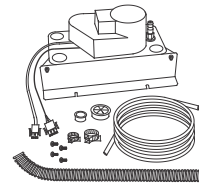

CONDENSATE PUMP KIT
CPC-1

FEET KIT, CFK-1

The CFK-1 is a field installed feet kit that replaces the casters used on the CoolCube 12, allowing the unit to be mounted in applications where movement is not desired. The feet are made of oil resistant neoprene and serve to reduce unit vibration and noise.

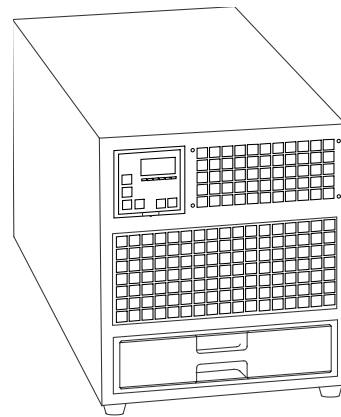
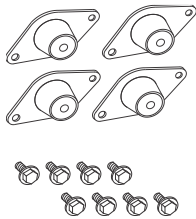

RACK DIFFUSER, CRD-1

The CRD-1 is a field installed diffuser kit that allows for the directional discharge of the conditioned air vertically into a rack application. The diffuser easily mounts to the front of the unit.

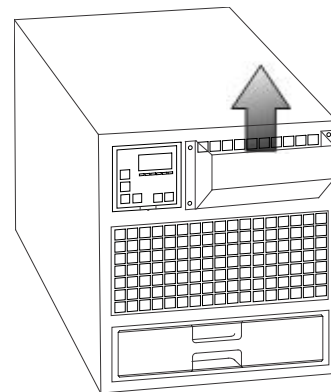
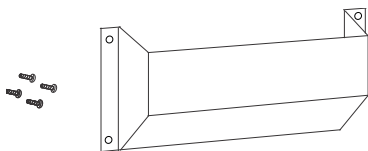

DISCHARGE AIR NOZZLE KIT ASSEMBLY (CNK-1)

The optional discharge nozzle kits are used to direct the conditioned air to a specific target area. By concentrating the airflow, the nozzles increase the air velocity towards production lines to cool personnel or equipment. In server rooms, the nozzles can be used to induce airflow through the rack to remove the hot air from the area of the equipment.

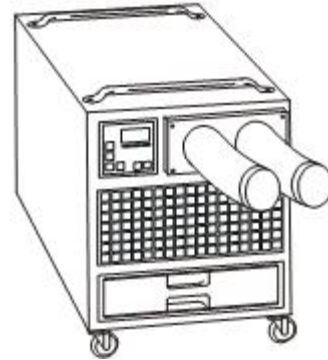

CNK-1 for model CoolCube 12 with (2) 4-inch diameter nozzles with an approximate compressed length of 15 inches. The approximate extended length is 21 inches.

DISCHARGE ADAPTER CDA-8

A discharge adapter is available for installations where it is required to duct air from the unit. The discharge adapter easily attaches to the evaporator and/ or the condenser discharge and provides an 8-inch flange for connecting 8-inch flexible ducting.

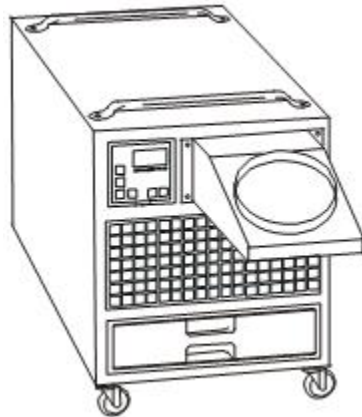
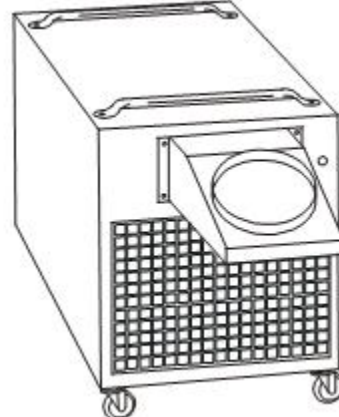
EVAPORATOR DISCHARGE**CONDENSER DISCHARGE**

EVAPORATOR RETURN AIR PLENUM, CEP-6

An evaporator return air plenum is available for installations where it is required to duct air to the inlet of the evaporator. The evaporator return air plenums allow the user to connect round duct (flexible or rigid) to the return air intake to reduce air noise and increase the number of options for solving difficult cooling problems. The plenum attaches to the front of the unit, replacing the return air grill.

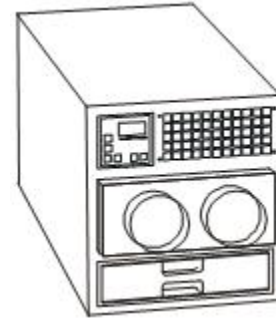

The CEP-6 transitions the return air opening to (2) 6-inch round ducts. The CEP-6 has space provided for a 16 X 8 Filter

NOTE—When a evaporator return air plenum is installed, it is recommended to set the evaporator blower speed to high, to avoid evaporator freeze-up.

CONDENSER RETURN AIR PLENUM, CCP-8

A condenser return air plenum is available for installations where it is required to duct air to the inlet of the condenser. The plenum easily attaches and is provided with an 8-inch flange for connecting 8-inch flexible ducting. The CCP-8 has space for a 16 X 14 filter.

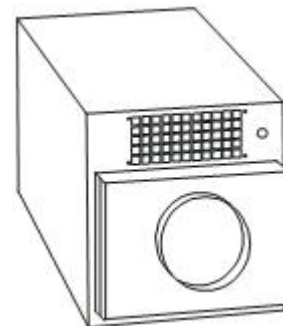

NOTE — When installing the condenser return air plenum with the ceiling panel kits, allow for a minimum separation distance of 2 feet between the unit discharge duct and the return air duct(s). It is also recommended to direct the condenser discharge air away from the condenser return air ducts.

REMOTE THERMOSTAT KIT, RTK-1

The RTK-1 is a field installed kit that allows for the display of the CAC1211 to be installed remotely, allowing the unit to be controlled from within the conditioned space. The kit includes a cover plate for the unit and a display installation panel.

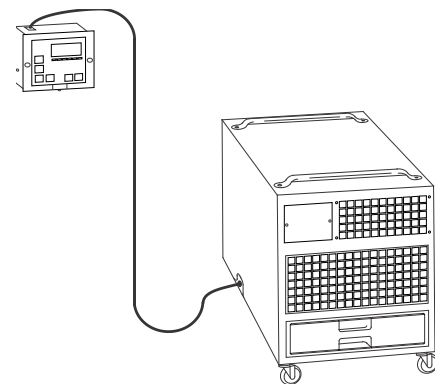

NOTICE - The RTK-1 requires a display cable (sold separately):
 012-006, 6 ft. Display Cable
 012-008, 75 ft. Display Cable
 012-009, 25 ft. Display Cable
 012-010, 50 ft. Display Cable

Deluxe Electronic Controller

The CoolCube 12 controller is equipped with many features for a more precise level of cooling and operation. Additionally, the controller can be removed from the unit and installed for remote operation, if desired—accessory parts may be required.

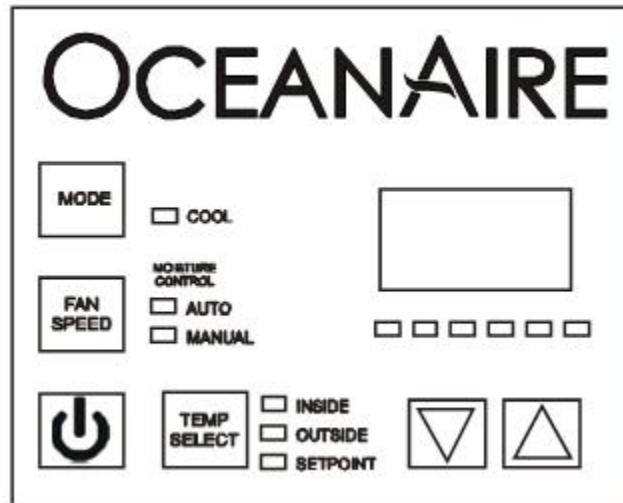

When power is connected, the controller will display “888” momentarily, and will then go blank. Press the POWER button, then press the TEMP SELECT button until the SET POINT is displayed. Adjust the SET POINT to the desired temperature, and the unit will heat/cool as required. **The systems controls temperature within +/- 2°**



Turns the unit ON/OFF when power is supplied. When ON, the display will light up and show the room temperature

MODE - Selects the mode of operation from COOL to Moisture Control.

COOL - The system will operate in cooling mode, only.

MOISTURE CONTROL - The system operates in the cooling mode to reduce humidity within the conditioned space. Every 4 hours, the fan is started, circulating the air, and the air temperature is recorded by the controller. The cooling cycle is started for one hour, or until the room temperature drops 2°, whichever comes first. This cycle repeats every four hours.

FAN SPEED—The operator can select between AUTO and MANUAL fan speed control. Pressing the FAN SPEED button, will switch speed from AUTO to MANUAL. In MANUAL mode, pressing the FAN SPEED button will change fan speed from low to high. In AUTO the fan speed is controlled automatically. In cooling mode, the controller automatically adjusts the fan speed to high, and as the inside temperature approaches the set point, the fan speed will reduce. In heat mode, the fan speed goes from low to high as the temperature approaches the set point

TEMP SELECT—Allows the operator to view the controller temperatures; INSIDE = return air temperature, OUTSIDE = supply air temperature, SET POINT can be seen and adjusted, by pressing ▲ or ▼.

CONTROLLER PROGRAMMING MENU

1. Make sure the unit has power.
2. Pushing the POWER button, turn the unit "OFF".
3. Press the following buttons in sequence "S-U-D-S":
4. The display will begin flashing P1 and a number.



If there is no display, repeat the sequence, making sure the unit has power, but is turned OFF.

5. To adjust any program parameter, press the ARROW UP ▲ or ARROW DOWN ▼ button until the desired value is displayed.
6. Use the "MODE" button to scroll through the programmable parameters P1 through P16.
7. If no buttons are pushed, the display will then return to the "OFF" position after about 50 seconds.

PROGRAMMING PARAMETERS

P1—High Fan Speed Limit Setting

P2—Low Fan Speed Limit Setting

P4—Temperature Sensor Calibration

P10— Temperature Display, °F or °C

P13—Supply Fan Operation, Cycling or Continuous

P1, P2 - To adjust fan speed settings, P1 represents the high fan speed parameter, while P2 represents the low fan speed parameter. When using nozzle kits, discharge duct adapters and evaporator plenums, setting P1 to 85 will help to avoid freeze ups.

P4 - Adjust the P4 setting to match the actual INSIDE room temperature, if needed.

P10 - Use this parameter to display temperatures in the desired units.

P13 - To cycle the evaporator fan with the compressor, access code P-13. Press the up or down button to switch to "CYC", which means cycle the fan with the compressor. The factory default setting is "CON", which means continuous fan operation.

8. Press POWER—you should see a code A (followed by numbers)
Press POWER and the unit will start at the new settings

CAC1211 PROGRAM PARAMETERS

MODEL	CODE SETTINGS
CAC1211	P1 = 80, P2 = 50

NOTICE - Program Parameters are NOT controller default values, they are Factory Settings.

DISPLAY FAULTS

LAC: Low AC line power

AAA: Failed Air Sensor (unit will not run)

CON: Empty Condensate Bucket—Units with a bucket

Condensate Pump Over-Flow Alarm—Units with pump

High Pressure Cut-Out—Low condenser air supply correct problem, and re-set unit at HP RESET

TO CHECK THE NUMBER OF HOURS ON THE UNIT

1. Disconnect unit power, and reconnect unit power.
2. When "888" appears in display, push and release the arrow down button
3. The first set of numbers displayed reads thousands of hours: 02 = 2000, 04 = 4000 hours, 00 means less than 1000 hours.
4. The second set of numbers read hours directly: 58 = 58 hours. 742 = 742 hours.
5. Add the 2 number sets together to get total hours. 03 and 486 = 3486 hours. 01 and 59 = 1059 hours.



TOTAL HOURS REPRESENTS COMPRESSOR "RUN" TIME

SERVICE

Troubleshooting Guide

The following steps and procedures are recommended for correcting the problems indicated. In the event that the problem cannot be corrected, service may be required.

PROBLEM: UNIT DOES NOT POWER UP

CAUSE: Power interruption

REMEDY: Check external power supply making sure that the disconnect is ON. Check for blown fuses or tripped circuit breakers. Reset or replace if needed.

CAUSE: LCDI has tripped

REMEDY: Check LCDI and reset LCDI on power cord.

CAUSE: Loose display cable

REMEDY: Re-seat display cable at display and power module.

PROBLEM: EVAPORATOR FAN RUNS BUT COMPRESSOR AND CONDENSER FAN DO NOT START

Note—there is a time delay for the compressor

CAUSE: SET POINT — setting may be too high for cooling.

REMEDY: Make sure set-point is adjusted accordingly. You should see a red dot to the right of the temperature display indicating compressor ON.

CAUSE: Loose Display Cable

REMEDY: Examine the control unit for loose wires. Tighten any loose connections.

CAUSE: Condition Alarm—"CON".

REMEDY: Check condensate tank and empty tank or check condensate pump and make sure pump is working properly and that there is no kink in the drain line from the pump.

CAUSE: High Pressure Cut-Out—"CON" Check High Pressure Cut-out Switch. Press Reset and clear away any obstructions to the condenser intake or condenser discharge.

CAUSE: Defective Power Module

REMEDY: Replace Power Module.

Replacement Procedure For Parts

IT IS RECOMMENDED THAT ALL COOLCUBE 12 UNITS BE SERVICED BY A LICENSED TECHNICIAN

WARNING—TO AVOID INJURY, DISCONNECT UNIT POWER PRIOR TO SERVICING

WARNING—HAZARDOUS MOVING PARTS DO NOT OPERATE UNIT WITH PANELS REMOVED

A. FAN MOTORS

1. Remove cabinet's left-side panel (when looking at the front of the unit).
2. Evaporator fan motor—disconnect evaporator motor wires from evaporator fan Motor leads on the power module (Fan L-1, Fan L-2). Condenser fan motor—disconnect condenser motor leads from power module (Pump L-1, Pump L-2). Remove the wire leads from the wire races accordingly, by cutting the wire ties.
3. Remove the screws securing motors and inlet-ring to blower housings (all screws are external and visible), and remove blower wheel-motor assembly. Remove the blower wheel set screw and disassemble the blower wheel from the motor shaft and remove the motor.
4. Install the new motor, reversing the removal procedure.
5. Re-secure all wires to the existing wire races with wire ties, making sure that all wires are secured from motion near moving parts.

B. ELECTRONIC CONTROLLER (2 PARTS)

1. To remove the Cooling Only display, locate the two screws securing the display to the front panel. Once the display is removed, unplug the display cable and remove the display. Install new display by plugging in the display cable and securing the display on to the cabinet front.
2. To remove the Power Module, remove the left side panel. Disconnect wires leads and cable connections going to the Power Module, and remove power module. Install new power module, and re-wire in accordance with the wiring diagram.

C. CONDENSATE PUMP (ON UNITS WITH CONDENSATE PUMP KITS, INSTALLED)

1. Remove the left side panel.
2. Remove bracket screws, securing condensate pump to the tank tray
3. Disconnect pump wire leads at Molex connectors. Remove retainer clamp and tubing.
4. Replace pump, install by reversing procedure.

D. HIGH PRESSURE SAFETY SWITCH

1. Remove the left side panel.
2. Remove flare nut that secures capillary to the refrigeration system high pressure side.
NOTE—A Schrader valve is located in the discharge port, and allows removal without losing the refrigerant charge.

3. Remove two screws that secure the high pressure switch to the back panel.
4. Cut the wire leads at a place approximately 6 inches from the switch.
5. Install new High Pressure Control, and splice the wire leads from the switch to the existing low-voltage wires.

To gain access to compressor and compressor run capacitor, remove top-right side panel.

Preventive Maintenance

CoolCube 12 are designed to last a long time and to give maximum performance and reliability with minimum maintenance. To prolong the life of the unit, regular maintenance must be performed as specified below:

BLOWER MOTORS

The motors on all units have permanently lubricated bearings. No oiling is necessary

FILTERS

A clogged filter will cause the unit to operate at greatly reduced efficiencies. We recommend that the filter be inspected on a regular bases every six weeks or more often depending on the environment. The evaporator filter is located behind the return air grille and can be easily removed and cleaned. The condenser filter is located in the lower backside of the unit. Remove by loosening one screw holding retaining clip and pull out. The filters must be washed periodically as needed by placing them in a dishwasher or soaking them in a solution of warm water and detergent for 10 minutes. Then rinsing them clean with hot water and shaking excess moisture from filter.

CONDENSATE PUMP

Condensate pumps come standard on all Size 60 models, and may be installed as options on size 12, 18, 24 and 36 models. When servicing pump follow these steps;

1. Make certain that the unit is disconnected from the power source before attempting to service or remove any component.
2. Be sure the floats move freely. Clean as necessary.
3. Remove the volute and check for obstructions. Clean as needed.
4. Clean the tank with warm water and mild soap when mineral deposits are visible.
5. Check the inlet and outlet piping. Clean as necessary. Be sure there are no kinks in the lines that would inhibit flow.

GENERAL

When necessary maintenance steps outlined above are followed, the air conditioner will provide long and reliable service. The refrigeration and electrical circuits of the system should only be serviced by a fully qualified service technician.

Piping Schematic

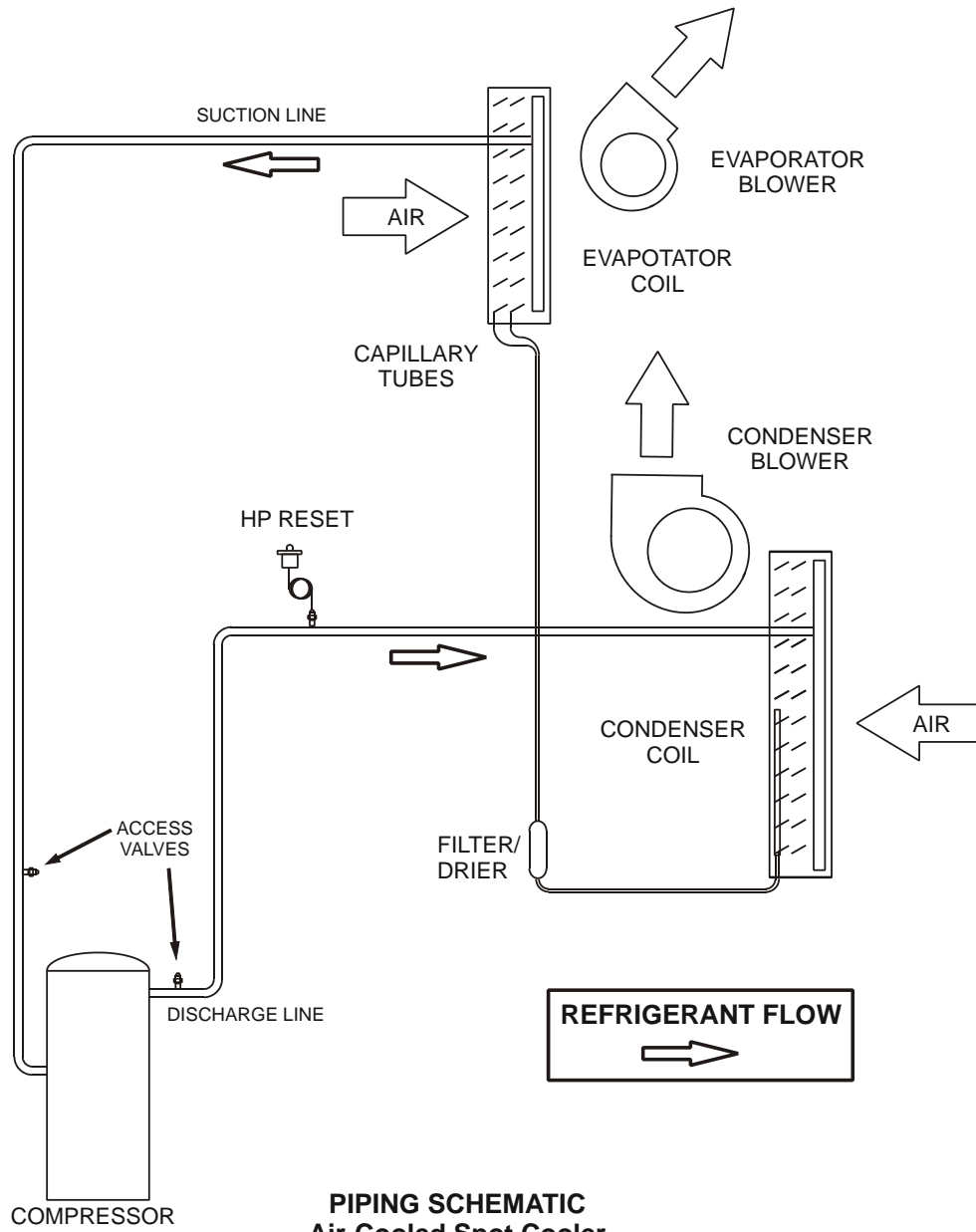

Wiring Diagram

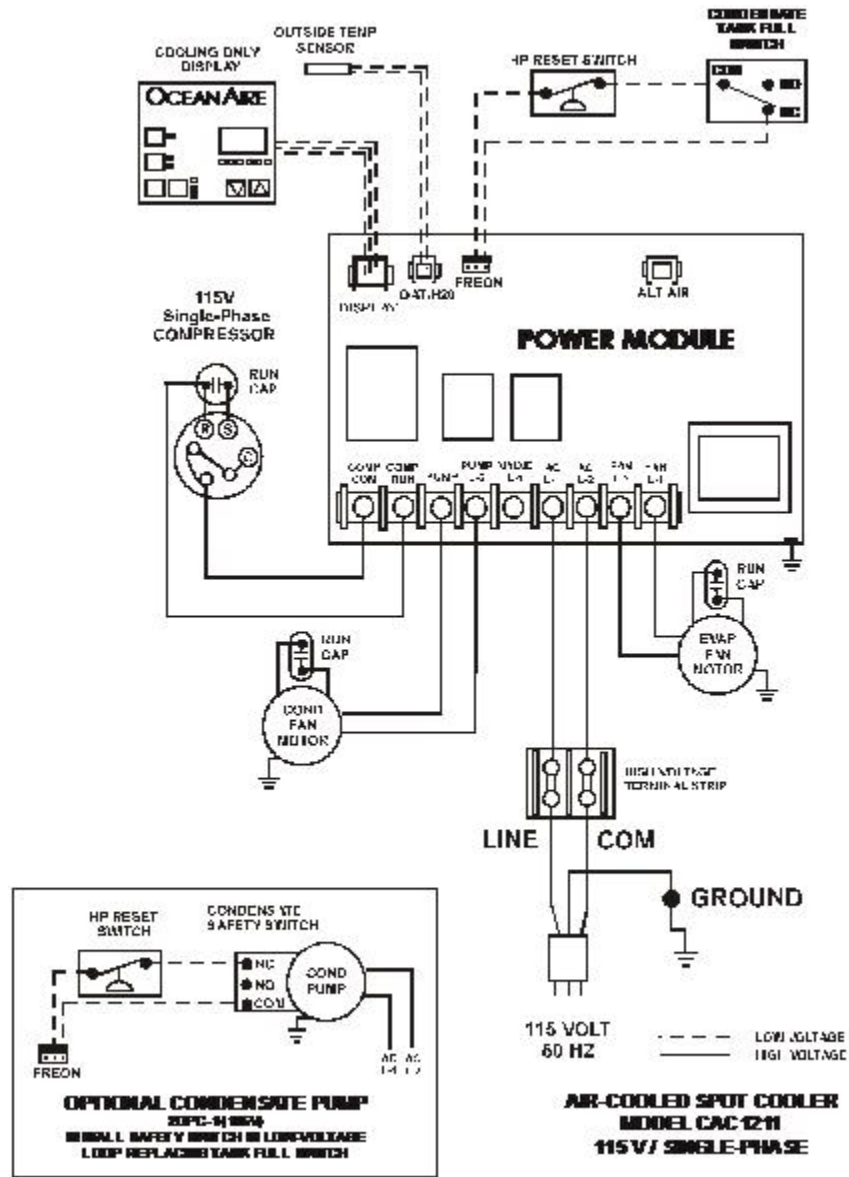

WHEN FIELD WIRING—USE COPPER CONDUCTORS ONLY

MANUFACTURER'S LIMITED WARRANTY

Xtreme Power Conversion warrants to the original owner that the Product will be free from defects in material or workmanship for a period not to exceed one (1) year from date of installation. If upon examination by the Manufacturer the Product is shown to have a defect in material or workmanship, during the warranty period, the manufacturer will repair or replace, at its option, that part of the Product which is shown to be defective.

The Manufacturer further warrants that the product's compressor-motor will be free from defects in materials and workmanship for five (5) years from the date of installation. If upon examination by the Manufacturer, the Compressor-Motor is shown to have a defect in materials or workmanship during the warranty period, the Manufacturer will repair or replace, at its option, that compressor which is shown to be defective. Electrical parts (such as relays, overloads, capacitors, etc.) and the sealed refrigeration system (condenser and evaporator) are included in the one year limited warranty, but not with the five year limited warranty of the compressor. This limited warranty does not apply:

- a) if the Product has been subjected to misuse or neglect, has been accidentally or intentionally damaged, has not been installed, maintained or operated in accordance with the furnished written instructions, or has been altered or modified in any way.
- b) to any expenses, including labor or material, incurred during removal or reinstallation of the Product.
- c) to any workmanship of the installer of the Product. This limited warranty is conditional upon:
 - (i) shipment, to the Manufacturer, of that part of the Product thought to be defective. Goods can only be returned with prior written approval from the Manufacturer. All returns must be freight prepaid.
 - (ii) determination, in the reasonable opinion of the Manufacturer that there exists a defect in material or workmanship.

Repair or replacement of any part under this Limited Warranty shall not extend the duration of the warranty with respect to such repaired or replaced part beyond the stated warranty period.

THIS LIMITED WARRANTY IS IN LIEU OF ALL OTHER WARRANTIES, EITHER EXPRESS OR IMPLIED, AND ALL SUCH OTHER WARRANTIES, INCLUDING WITHOUT LIMITATION IMPLIED WARRANTIES OF MERCHANTABILITY OR FITNESS FOR A PARTICULAR PURPOSE, ARE HEREBY DISCLAIMED AND EXCLUDED FROM THIS LIMITED WARRANTY. IN NO EVENT SHALL THE MANUFACTURER BE LIABLE IN ANY WAY FOR ANY CONSEQUENTIAL, SPECIAL, OR INCIDENTAL DAMAGES OF ANY NATURE WHATSOEVER, OR FOR ANY AMOUNTS IN EXCESS OF THE SELLING PRICE OF THE PRODUCT OR ANY PARTS THEREOF FOUND TO BE DEFECTIVE. THIS LIMITED WARRANTY GIVES THE ORIGINAL OWNER OF THE PRODUCT SPECIFIC LEGAL RIGHTS. YOU MAY ALSO HAVE OTHER RIGHTS WHICH MAY VARY BY EACH JURISDICTION.

USEFUL INFORMATION

MODEL: _____

SERIAL NUMBER: _____

DATE PURCHASED: _____

INSTALLED BY: _____

DATE INSTALLED: _____