

PROTECT YOUR INVESTMENT!
Completed and signed start-up forms
MUST be submitted and approved
by Tripp Lite to activate your warranty.



Owner's Manual

SmartOnline™ 3-Phase UPS System

Model: SU80K

Input/Output: 120/208V AC, 50/60 Hz, 3Ø, 4-wire + ground

Not suitable for mobile applications.



1111 W. 35th Street, Chicago, IL 60609 USA
www.tripplite.com/support

Copyright © 2010 Tripp Lite. All trademarks are the sole property of their respective owners.

Table of Contents

1	Introduction	3
2	Important Safety Instructions	4
3	Control Panel Features	6
4	Front and Rear Panel Features	7
5	Cabinet Installation	9
5-1	Preparation	9
5-2	Unpacking	9
5-3	Placement	10
6	Wiring	11
6-1	Wiring Warnings	11
6-2	Wiring Preparation	11
6-3	UPS System Terminal Block Diagram	12
6-4	External Battery Cabinet Wiring Diagrams	12
6-5	Electrical and Cable Data	13
6-6	External Battery Cabinet Wiring	14
6-7	AC Input/Output Wiring (Single UPS)	15
6-8	AC Input/Output Wiring (Parallel UPS – Single Input)	16
7	Operating Modes	17
7-1	Online (Normal) Mode (Single UPS)	17
7-2	Battery Backup Mode (Single UPS)	17
7-3	Auto Bypass Mode (Single UPS)	17
7-4	Manual Bypass Mode (Single UPS)	17
7-5	Online Mode (Parallel UPS)	18
7-6	Battery Backup Mode (Parallel UPS)	18
7-7	Auto Bypass Mode (Parallel UPS)	18
7-8	Manual Bypass Mode (Parallel UPS)	19
8	Start-Up, Shutdown and Bypass	20
8-1	Control Panel and Breaker Diagrams	20
8-2	Preliminary Checklist (Single UPS)	20
8-3	Normal Start-Up Procedure (Single UPS)	20
8-4	Battery Start-Up Procedure (Single UPS)	21
8-5	Manual Bypass Procedure (Single UPS)	22
8-6	Shutdown Procedure (Single UPS)	22
8-7	Preliminary Checklist (Parallel UPS)	23
8-8	Start-Up Procedure (Parallel UPS)	24
8-9	Shutdown Procedure (Parallel UPS)	25
8-10	Manual Bypass Procedure (Parallel UPS)	26
8-11	Switching from Manual Bypass to Normal (Parallel UPS)	27

9	Display and Configuration	28
9-1	Control Panel Diagram	28
9-2	Display Hierarchy	28
9-3	Default Display	29
9-3-1	Status Display	29
9-4	Main Menu	32
9-5	UPS Setup	34
9-5-1	Bypass Setup	35
9-5-2	Output Setup	36
9-5-3	Battery Setup	38
9-5-4	Charger Setup	41
9-5-5	Parallel Setup	42
9-5-6	Control & Test Setup	43
9-5-7	Local Setup	45
9-6	Maintenance	48
10	Communications	50
10-1	Communications Interfaces	50
10-2	SNMPWEBCARD Slot	50
10-3	Input Dry Contact Interface	50
10-4	Remote Emergency Power Off (EPO) Circuit Diagram	51
10-5	Auxiliary Dry Contact Input Circuit Diagram	51
10-6	External Battery Cabinet Temperature Inputs	51
10-7	External Battery Status Input	51
10-8	Output Dry Contact Interface Detail	52
10-9	Output Dry Contact Circuit Diagram	53
10-10	RS-232 Serial Port Circuit Diagram	54
10-11	Parallel Configuration Port	54
11	Specifications	55
11-1	UPS System Technical Specifications	55
11-2	UPS System Floor Loading Table	55
11-3	Battery Pack Floor Loading Table	55
12	Storage and Service	56
13	Warranty and Warranty Registration	56

Tripp Lite's SmartOnline 3-Phase UPS Systems are ideal for backing up and protecting data centers, telecommunications (VoIP), networks, industrial facilities, security/emergency systems and more.

Advanced Features:

- True on-line double conversion with superior IGBT inverter technology
- Low input current THD allows 1:1 generator sizing for maximum efficiency and cost savings
- Internal N+1 power module redundancy
- Built-in parallel redundancy (1+1) capability for increased capacity or fault-tolerance
- Up to 80kVA capacity in a compact footprint; up to 160kVA in parallel configuration
- High input power factor and high efficiency with low thermal loss and low noise
- Simplified, easy-to-repair, long-life, high-availability system design
- Redundant auxiliary power and control circuits
- All models support external battery cabinets for extended battery backup runtime
- High-resolution LCD status screen simplifies operation and delivers detailed operational information, including system block diagrams



2 – Important Safety Instructions

SAVE THESE INSTRUCTIONS

All sections of this manual contains instructions and warnings that should be followed during the installation and operation of the UPS systems described in this manual. Read all instructions thoroughly before attempting to move, install or operate the UPS systems described in this manual. Failure to comply may invalidate the warranty and cause property damage and/or personal injury.

Location Warnings

- Install the UPS system in a controlled indoor environment, away from moisture, temperature extremes, flammable liquids and gasses, conductive contaminants, dust and direct sunlight.
- Install the UPS system in a level, structurally sound location.
- The UPS system is extremely heavy; be extremely careful when moving or lifting the unit.
- Operate the UPS system at indoor temperatures between 32° F and 104° F (0° C and 40° C) only. For best results, maintain indoor temperatures between 62° F and 84° F (17° C and 29° C).
- Leave adequate space around all sides of the UPS system for proper ventilation. Do not block, cover or insert objects into the external ventilation openings of the cabinet.
- Do not place any object on the unit, especially containers of liquid.
- Do not mount the unit with its front or rear panel facing down (at any angle). Mounting in this manner will seriously inhibit the unit's internal cooling, eventually causing product damage not covered under warranty.
- Do not install the UPS system near magnetic storage media, as this may result in data corruption. Keep all recorded magnetic media a minimum of 60 cm (24 inches) away from the UPS system.
- Do not attempt to stack the UPS system. Attempting to stack the UPS system may cause permanent damage and create a potential for serious personal injury.
- The casters are designed for minor position adjustments within the final installation area only. The casters are not designed for moving the UPS system over longer distances.
- The casters are not designed to provide long-term support for the UPS system after final installation. Use the levelers to provide long-term support.
- When moving the UPS system, push from the front or rear, not from the sides.
- Do not attempt to unpack or move the UPS system without assistance.

Connection Warnings

- **The power supply for this unit must be three-phase rated in accordance with the equipment nameplate. It also must be suitably grounded and wired according to all applicable national and local electrical wiring codes and regulations.**
- The UPS system contains hazardous high voltages that have the potential to cause personal injury or death from electric shock.
- The UPS system has its own energy source (battery – internal and/or external). The output terminals may be live even when the UPS system is not connected to an AC supply.
- If the UPS system receives power from a motor-powered AC generator, the generator must provide clean, filtered, computer-grade output.
- Use of this equipment in life support applications where failure of this equipment can reasonably be expected to cause the failure of the life support equipment or to significantly affect its safety or effectiveness is not recommended. Do not use this equipment in the presence of a flammable anesthetic mixture with air, oxygen or nitrous oxide.
- The UPS system is designed to power modern computer loads and associated peripheral devices. Do not use the UPS system to power pure inductive or capacitive loads.
- Input and output wiring should be performed by trained, qualified electricians only.
- Due to high leakage current, a proper earth ground connection is essential before connecting the AC supply.
- Isolate the UPS system before working on the circuit. An easily accessible disconnect device should be incorporated in the fixed wiring. The disconnect device must disconnect all line conductors simultaneously when opened.

Battery Warnings

- The UPS system does not require routine maintenance. There are no user-serviceable parts inside. Only qualified service personnel should open the access panels for any reason.
- Batteries present a risk of electrical shock and burns from high short-circuit current. Battery connection or replacement should be performed only by qualified service personnel, observing proper precautions. Turn off the UPS system before connecting or disconnecting internal batteries. Use tools with insulated handles. Do not open the batteries. Do not short or bridge the battery terminals with any object.
- Replace batteries with equivalent batteries available from Tripp Lite. Do not operate the UPS system without batteries.
- The batteries are recyclable. Refer to local codes for disposal requirements.
- Do not dispose of the batteries in a fire, mutilate the batteries or open the battery coverings.
- Battery fuses should be replaced by qualified service personnel only. Blown fuses must be replaced with the same number and type of fuses.
- Potentially lethal voltages exist within the UPS system as long as the battery supply is connected. Service and repair should be performed by trained personnel only, while the UPS system is turned off or placed into bypass mode. Disconnect internal batteries (if present) before performing any service work by switching off the internal battery circuit breaker and removing the battery fuse(s). Disconnect external batteries (if present) by switching off the external battery cabinet breaker and disconnecting the external battery cabling from the UPS system.
- Do not connect or disconnect batteries when the UPS system is operating from the battery supply or when the unit is not in bypass mode.
- Do not remove the plastic sleeves covering internal batteries.
- Internal and external batteries must be replaced by equivalent batteries available from Tripp Lite.
- Before connecting an external battery cabinet to the UPS system, read the external battery cabinet's documentation. Use only external battery cabinets that have been approved by Tripp Lite.
- If the UPS system remains off for an extended period of time, it should be turned on periodically to allow the batteries to recharge. The UPS system should be turned on and the batteries should be recharged at least one uninterrupted 24-hour period every 3 months. Failure to recharge the batteries periodically may cause irreversible battery damage.

Wiring Warnings

- See [Section 6-1](#) for wiring warnings

3 – Control Panel Features

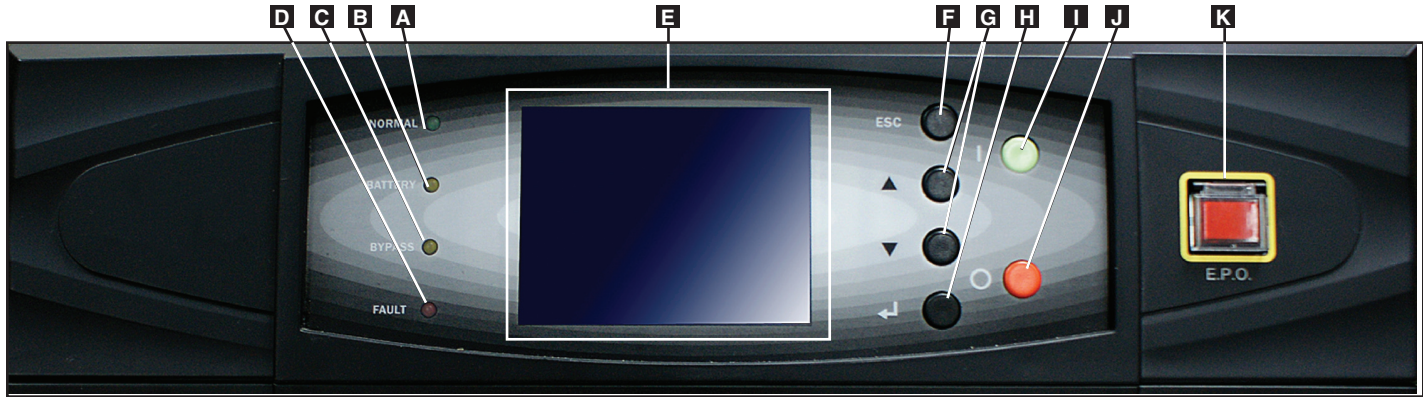

- A** **“NORMAL” LED:** This green light illuminates to indicate that the UPS system is in online (normal) mode. The primary AC input supply is present and within standard operating parameters.
- B** **“BATTERY” LED:** This amber light illuminates when the UPS system is in battery backup mode, discharging the batteries to provide power to connected equipment. An audible alarm will also sound.
- C** **“BYPASS” LED:** This amber light illuminates when the UPS system is in bypass mode (auto bypass or manual bypass). Battery backup power will not be available to connected equipment while the UPS system is in bypass mode, but connected equipment loads will be supported by the bypass power source.
- D** **“FAULT” LED:** This red light illuminates when any UPS system or input power fault occurs. Available diagnostic information will be displayed on the LCD screen.
- E** **LCD Status Screen:** This illuminated LCD status screen displays text and graphics to indicate a wide range of UPS system operating conditions and diagnostic data. *Note: The LCD backlight will turn off after 10 minutes of inactivity. Turn on the backlight by momentarily pressing the ON button or one of the scroll buttons.*
- F** **“ESC” (Escape) Button:** Press this button to return to the previous page or menu.
- G** **Scroll Buttons (▲ and ▼):** Press these buttons to move the cursor up or down and navigate the control panel menus and screens. These buttons are also used for data entry in several screens.
- H** **Enter Button (↵):** Press this button to select a menu item or confirm a setting change.
- I** **ON Button:** Press and hold this button for 3 seconds to turn the UPS system’s inverter ON.
- J** **OFF Button:** Press and hold this button for 3 seconds to turn the UPS system’s inverter OFF. If the UPS system is in online (normal) mode, it will switch to auto bypass mode.
- *Note: Switching the inverter OFF does not stop the converter stage of the UPS and therefore, the connected battery is still charging as required.*
 - *Note: After switching the inverter OFF, if the battery circuit breaker or AC main input circuit breaker are opened and remain open for an extended period of time, the batteries should be recharged periodically. At a minimum, the batteries should be charged for an uninterrupted 24-hour period every 3 months to maintain their longest usable life. Failure to recharge the batteries may cause irreversible battery damage.*
- K** **“EPO” (Emergency Power Off) Button:** Press this button to turn the UPS system’s output OFF and also disable bypass output.

If the UPS system is in battery backup mode when the EPO button is activated:

- Main output and bypass output are turned off, the alarm sounds, fans shut down after approximately one minute, and control circuitry remains active.
- Releasing the EPO button (by pressing it again) turns off the UPS system completely, including the alarm and control circuit. Press the ON button for 3 seconds to restart the UPS system.

If the UPS system is in online (normal) mode when the EPO button is activated:

- Main output and bypass output are turned off, the alarm sounds, fans and control circuitry remain active.
- Releasing the EPO button (by pressing it again) turns off the alarm and places the UPS system in auto bypass mode. Press the ON button for 3 seconds to return the UPS system to online (normal) mode.

See [Section 9 – Display and Configuration](#) for detailed information about the control panel’s menus and displays.

4 – Front and Rear Panel Features

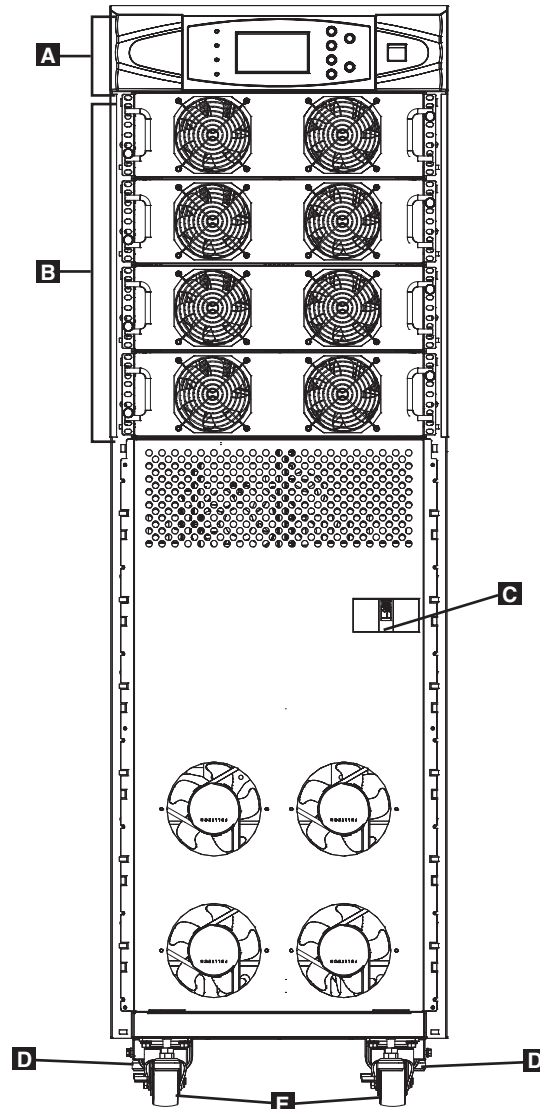

SU80K shown (front)

Note: Individual models may vary from diagrams. Unit shown with front bezels removed.

- A Control Panel:** The control panel allows the operator to monitor and control the UPS system. See [Section 3 – Control Panel Features](#) for more information.
- B Internal Power Modules:** 20kVA internal power modules can be replaced in the field without powering down connected equipment loads. The number of internal power modules varies by model. The internal power modules are capable of N+1 redundancy.
- C Main Input Circuit Breaker Switch (Q1):** Controls AC input power to the UPS system during online (normal) operation.
- D Levelers:** The levelers provide long-term support for the UPS system.
- E Casters:** The casters are designed for small position adjustments within the final installation location only; they are not designed for moving the UPS system over longer distances. The casters are not designed to provide long-term support for the UPS system after final installation. Use the levelers to provide long-term support.

4 – Front and Rear Panel Features (continued)

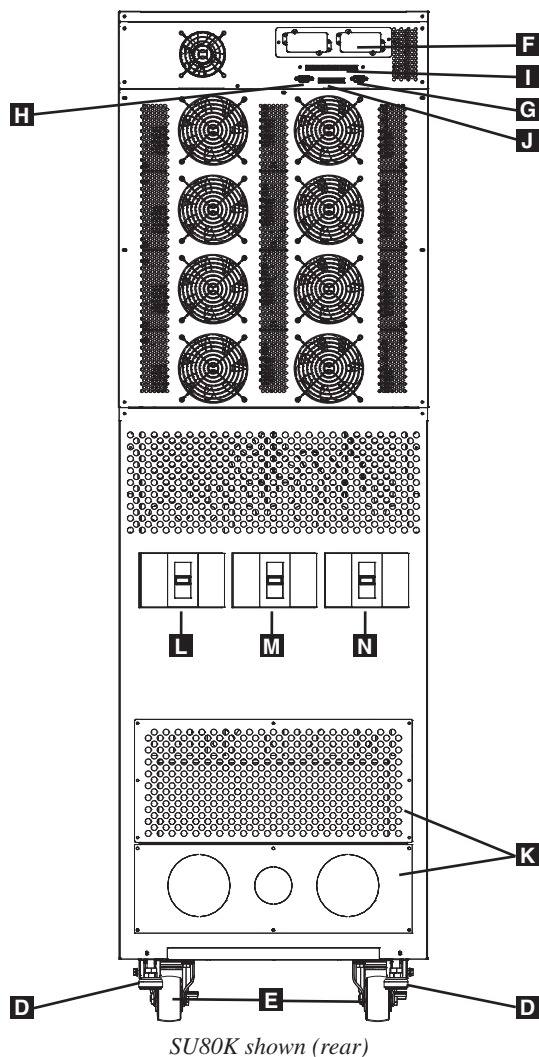

Note: Individual models may vary from diagrams. Unit shown with breaker guard removed.

- D Levelers:** The levelers provide long-term support for the UPS system.
- E Casters:** The casters are designed for small position adjustments within the final installation location only; they are not designed for moving the UPS system over longer distances. The casters are not designed to provide long-term support for the UPS system after final installation. Use the levelers to provide long-term support.
- F Accessory Slot:** Remove the cover panel to install a Tripp Lite SNMPWEBCARD accessory. The SNMPWEBCARD accessory provides an Ethernet interface for the UPS system and enables remote monitoring and control via SNMP, Web browser or telnet. Visit www.tripplite.com for more information about the SNMPWEBCARD accessory.
- G RS-232 Serial Communications Port:** This DB9 port connects the UPS system to compatible workstations or servers, enabling automatic shutdown during extended blackouts and monitoring of operating and power conditions.
- H Parallel Redundancy Port:** This DB9 port connects the UPS system to another UPS system of identical type and capacity for use in a parallel redundancy (1+1) configuration. See [Section 6 – Wiring](#) and [Section 7 – Operating Modes](#) for more information.
- I Input Dry Contact Interface:** This interface receives dry contact signals that allow the UPS system to receive commands and monitor external battery conditions. See [Section 10 - Communications](#) for more information.
- J Output Dry Contact Interface:** This interface allows the UPS system to send information via dry contact communications. See [Section 10 – Communications](#) for more information.
- K Terminal Block Cover:** Remove the terminal block cover to access the UPS system’s input, external battery cabinet, output and grounding connection terminals. Wiring conduits pass through the circular knockouts in the terminal block cover. The UPS system includes alternate circular knockouts in the bottom panel. See [Section 6 – Wiring](#) for more information, including a detailed diagram of the terminal block.
- L Bypass Input Circuit Breaker Switch (Q2):** Controls AC input power to the UPS system during auto bypass operation.
- M Manual Bypass Circuit Breaker Switch (Q3):** Controls AC input power to the UPS system during manual bypass operation.
- N Output Circuit Breaker Switch (Q4):** Controls AC output power.

5 – Cabinet Installation



Read **Section 2 – Important Safety Instructions** Before Installation



5-1 Preparation

The UPS system must be installed in a structurally sound area with a level floor that is able to bear the weight of the UPS system, any external battery cabinet and other equipment that will be installed nearby. The installation site should also have a dedicated AC circuit available that is compatible with the UPS system's input requirements. (See **Section 11 – Specifications** for details on input requirements and floor loading requirements.) Before unpacking the unit, you should transport the shipping container closer to the final installation site to minimize the distance you will need to move the unit after the protective shipping container has been removed. If you plan to store the UPS system for an extended period before installation, follow the instructions in **Section 12 – Storage and Service**. (Unpacking and storage instructions are also printed on the "Unpacking and Storage Instructions" sheet secured to the shipping container.) **Warning: Do not attempt to unpack or move the UPS system without assistance.**

5-2 Unpacking

1-2 Inspect the shipping container(s) for visible damage. If you determine that the unit has been damaged during shipping, contact Tripp Lite for assistance. Do not attempt to use the UPS system if it has been damaged or mishandled.

Confirm that the shipping container is upright and use a screwdriver to remove its top panel, front panel and back panel. Also remove the plastic wrap and interior cushioning material. Confirm that the model name and rating at the rear of the cabinet match the unit you ordered. Examine the cabinet for any damaged or loosened parts. Confirm that the shipping container includes the accessories that ship with the unit. The UPS system should include an RS-232 serial cable, a parallel redundancy cable, a remote EPO wiring connector, a dry contact input connector (4 contacts), a dry contact output connector (12 contacts) and a software CD-ROM. If anything is missing or damaged, contact Tripp Lite for assistance.

Confirm that the unit is stable, then remove the side panels from the shipping container.

3 Remove the bolts from the shipping brackets securing the unit to the pallet, then remove the shipping brackets from the UPS system. **Warning: Be extremely careful, as the unit could shift unexpectedly.**

Use several of the screws you removed in step 1 to attach the top panel of the shipping container to the front edge of the shipping pallet. The smooth surface of the panel should face upward so that it can be used as a ramp for rolling the unit off the shipping pallet. Do not attempt to use the top panel as a ramp if it is cracked or otherwise structurally damaged. Make sure the casters at the bottom of the unit are unlocked. Using extreme caution, slowly roll the unit down the ramp with the aid of several assistants.

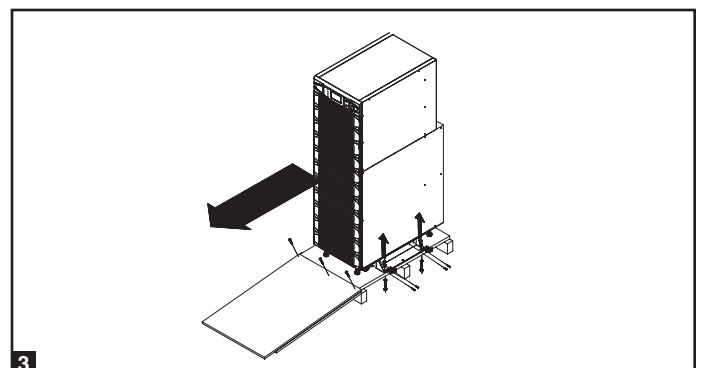
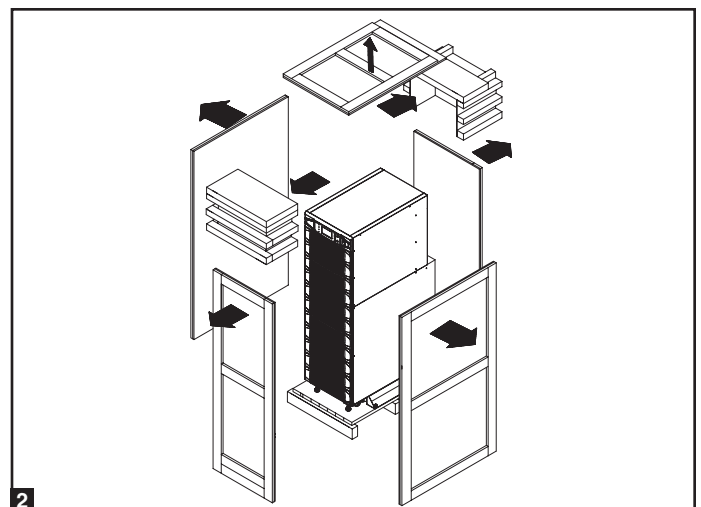
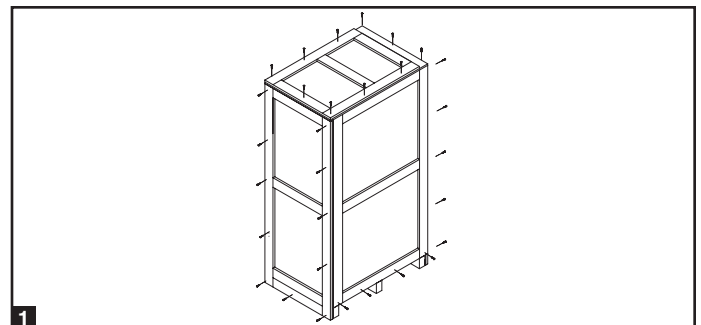

5 – Cabinet Installation (continued)

5-3 Placement

1 Use the casters to move the UPS system for a short distance over a level, smooth, stable surface. Do not attempt to use the casters to move the UPS system over longer distances. The UPS system should be moved close to its final installation location inside its shipping container before it is unpacked from the shipping container. Use a mechanical device of sufficient capacity to move the shipping container. **Warning: The UPS system could tip if it is moved over an unstable surface. Be extremely careful when moving the UPS system. Push the UPS system from the front or rear, not from the sides.**

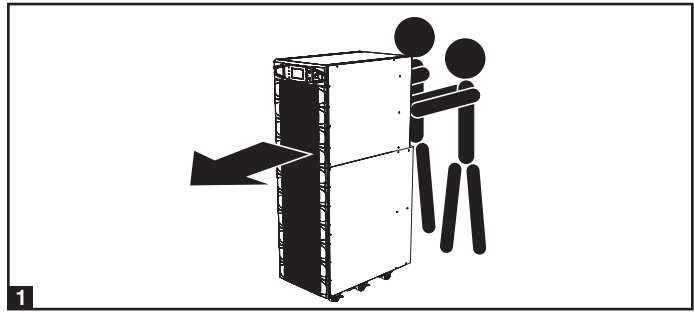

2 Position the UPS system in a structurally sound area with a level floor that is able to bear the weight of the UPS system, any external battery cabinets and other equipment that will be installed nearby. The installation site should also have a dedicated AC circuit available that is compatible with the UPS system's input requirements. (See **Section 11 – Specifications** for more information about input requirements and floor loading requirements.) The UPS system must be installed in a clean, secure environment with a relative humidity less than 90% (non-condensing). Operate the UPS system at indoor temperatures between 17° C and 29° C (62° F and 84° F). Prevent damage to cabling by using suitable protective conduits. In order to maintain proper airflow and service access, you must maintain the following clearances:

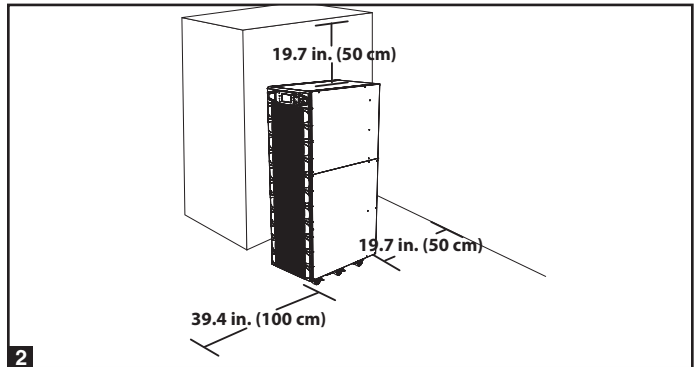

- At least 39.4 in. (100 cm) clearance in front of the UPS system.
- At least 19.7 in. (50 cm) clearance behind the UPS system.
- At least 19.7 in. (50 cm) clearance above the UPS system.

Warning: The cooling fans circulate air from front to back. Do not use any air conditioning or fan that blows air directly toward the rear of the UPS system.

3 After moving the UPS system to its final location, lock the casters **A** and use the levelers **B** to stabilize the cabinet. Ensure that all four levelers make firm contact with the floor.

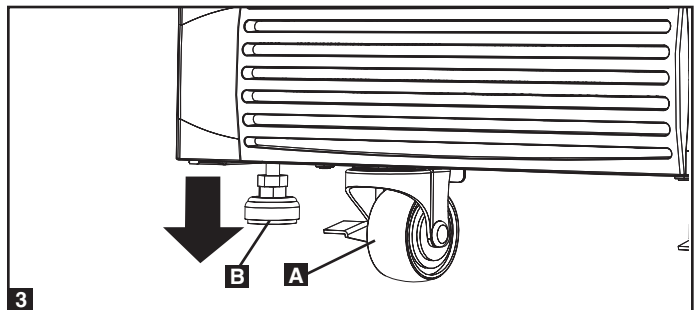

4 For emergency use, install a fire extinguisher rated for energized electrical equipment fires (Class C rating or exact equivalent, with a non-conductive extinguishing agent) near the UPS system.

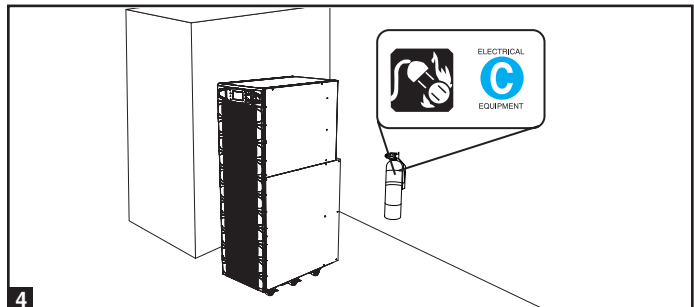

6 – Wiring



DANGER! LETHAL HIGH VOLTAGE HAZARD!

All wiring should be performed by a qualified electrician, in accordance with the warnings in this manual and all applicable electrical and safety codes. Incorrect wiring may damage the UPS system severely and cause serious personal injury and property damage. Read [Section 2 – Important Safety Instructions](#) before proceeding.

6-1 Wiring Warnings

- De-energize all input and output power sources of the UPS system before installing cables or making electrical connections.
- Use flexible cable of sufficient length to permit UPS system servicing. The maximum cable length is 10 m (32.8 ft).
- Use ferrule caps to cover termination cables and prevent frayed ends from shorting on the UPS system terminal block.
- Use cabling rated VW-1, FT-1 or better.
- Use cable sleeves and connector clamps.
- The neutral conductor must be the same size as the current conductors.
- Tighten all connections with a torque of at least 3.95 N·m (35 in·lb)
- Confirm that all cables are marked correctly according to their purpose, polarity, phase and diameter.
- If the UPS system's input/output power source is wye-wye, then "Neutral" and "Ground" must not be connected.
- If the input power source has $V_{NG} > 0$, install a grounded wye secondary isolation transformer with a properly bonded neutral to ground, before the UPS system and input power source.
- For equipment requiring a neutral connection to an IT power distribution system that requires neutral isolation upon disconnect, the disconnect device must be a four-pole device and must disconnect all line conductors and the neutral conductor. If a disconnect device interrupts the neutral conductor, it must simultaneously interrupt all line conductors.
- Allow the batteries to charge uninterrupted for 24 hours after the initial wiring connection.
- Observe proper polarity by connecting negative to negative, positive to positive and Normal "N" to Normal "N". Failure to observe proper polarity will damage the UPS system and create a serious risk of personal injury and property damage.
- Observe proper phase by connecting R to R, S to S, T to T and N to N. Source power phase rotation must be verified as RST before powering the UPS. Failure to observe proper phase will damage the UPS system and create a risk of personal injury and property damage.

6

6-2 Wiring Preparation

- De-energize all input and output (AC and DC) of the UPS system and external battery cabinet (if present).
- Mark all cables according to their correct purpose, polarity, phase and diameter.
- Review the diagrams in [Section 6-3](#) and [Section 6-4](#) to familiarize yourself with the terminal blocks.
- Consult the table in [Section 6-5](#) to find the correct electrical input/output characteristics for the UPS system.

Note: If the UPS system's input/output power source is wye-wye, then "Neutral" and "Ground" must not be connected. If the input power source has $V_{NG} > 0$, install an isolation transformer before the UPS system and input power source, then connect the UPS system's "Neutral" and "Ground" together.

6-3 UPS System Terminal Block Diagram

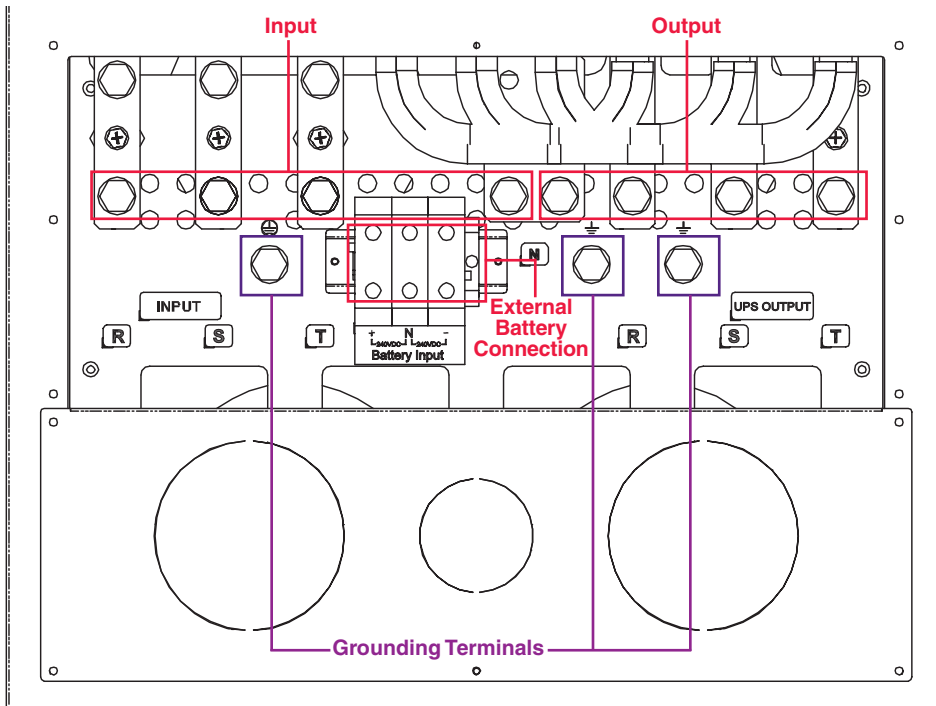

6-4 External Battery Cabinet Wiring Diagrams

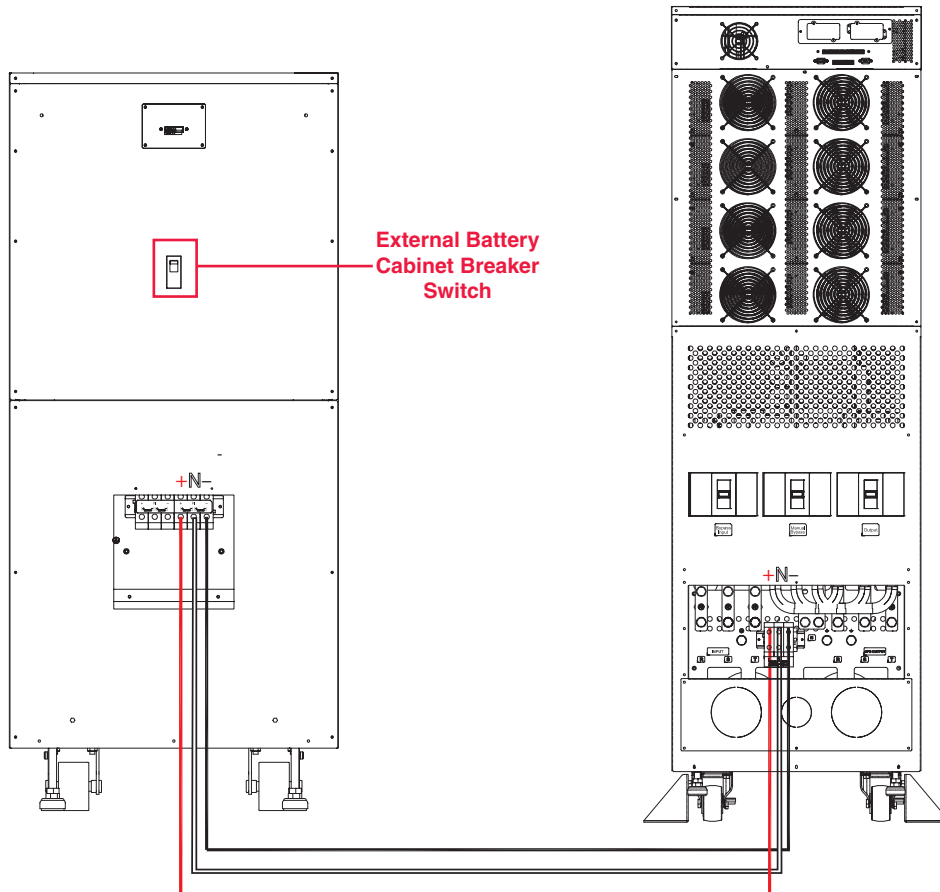

SU80K and BP480V40C shown for illustration only; consult the battery cabinet's documentation for exact specifications

6 – Wiring (continued)

6-4 External Battery Cabinet Wiring Diagrams (continued)

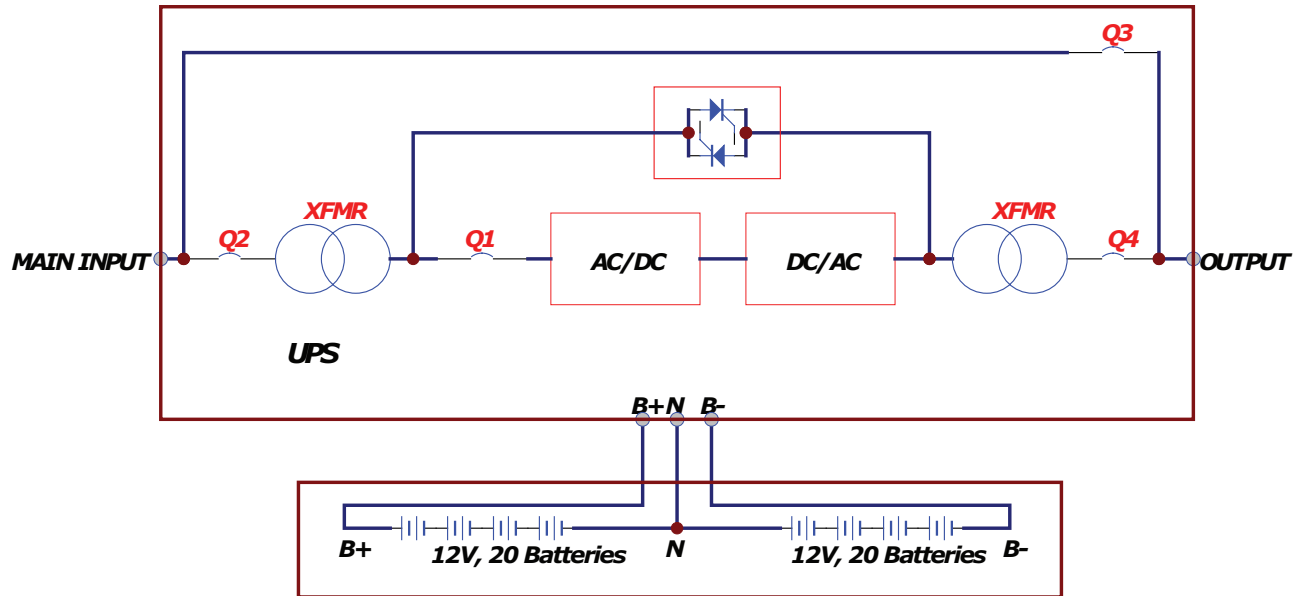

External Battery Cabinet

B Cabinet: 26AH per Battery - 125A Fuses

C Cabinet: 40AH per Battery - 160A Fuses

10 Year Cabinet: 55AH, 78AH, 103AH, 140AH-250A CB

6-5 Electrical and Cable Data

Model	Input/Output	Input and Output Breaker Size	Input and Output Cable Size	Battery Circuit Breaker/Fuse Size	Battery Cable Size
SU80K	120/208V AC, 3Ø, 4-wire + ground	300A	4/0 AWG	125A 160A 250A	1 AWG 2/0 AWG 2/0 AWG

6-6 External Battery Cabinet Wiring

Warning: External battery cabinets vary. Read the external battery cabinet’s documentation before attempting to connect it to the UPS system. Use only external battery cabinets that have been approved by Tripp Lite.

Note: An external battery cabinet is required. Contact Tripp Lite for external battery cabinet ordering information.

- 1** De-energize all input and output (AC and DC) of the UPS system and external battery cabinet, and confirm that the external battery cabinet breaker switch **A** is off. (If the UPS system has already been wired to an AC power source, see [Section 8-6](#) for shutdown instructions.)
- 2** Remove the terminal block covers from the UPS system and external battery cabinet.
- 3** Connect the positive (+), neutral (N) and negative (-) UPS system connection terminals of the external battery cabinet to the corresponding positive (+), neutral (N) and negative (-) external battery connection terminals of the UPS system. See [Section 6-3](#) and the external battery cabinet’s documentation for terminal block diagrams. See [Section 6-4](#) for wiring diagrams. See [Section 6-5](#) for cable size requirements. Cabling should be protected by flexible conduit and routed through the appropriate knockouts in the terminal block cover. **Warning: Observe proper polarity by connecting negative to negative and positive to positive. Failure to observe proper polarity will damage the UPS system and create a risk of personal injury and property damage.**
- 4** Connect the external battery cabinet’s grounding terminal **A** to the UPS system’s corresponding grounding terminal **B** with a 4 AWG (5.189 mm) ground cable. Keep the ground cable connected at all times after installation.
- 5** Connect the UPS system’s grounding terminal **A** to your facility’s earth ground **B** with a 4 AWG (5.189 mm) minimum ground cable. Keep the ground cable connected at all times after installation.
- 6** Replace the terminal block cover of the external battery cabinet. If you do not plan to wire the AC input/output of the UPS system at this time, replace the terminal block cover of the UPS system.

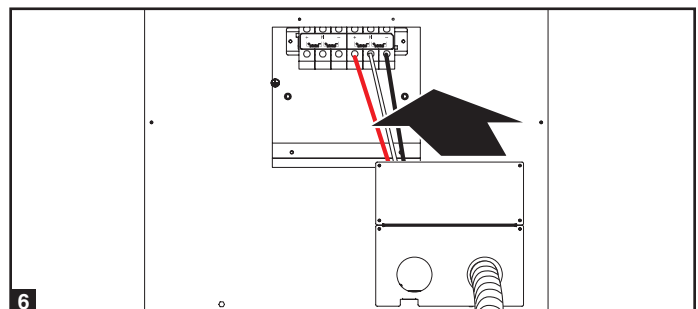
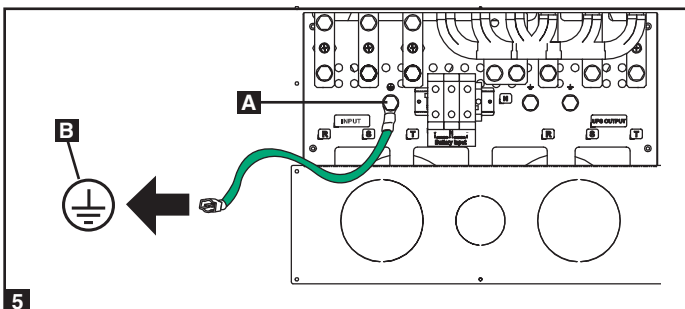
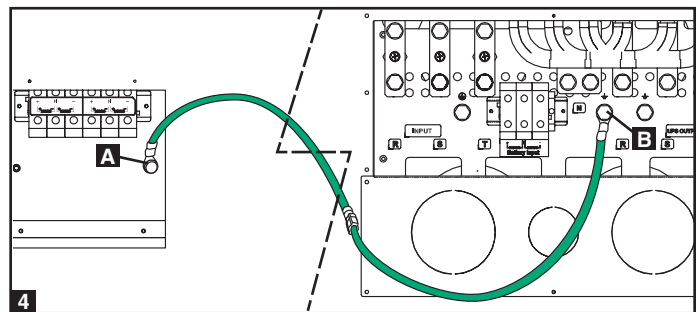
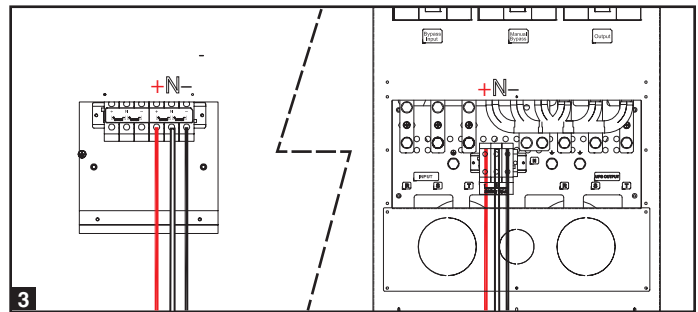
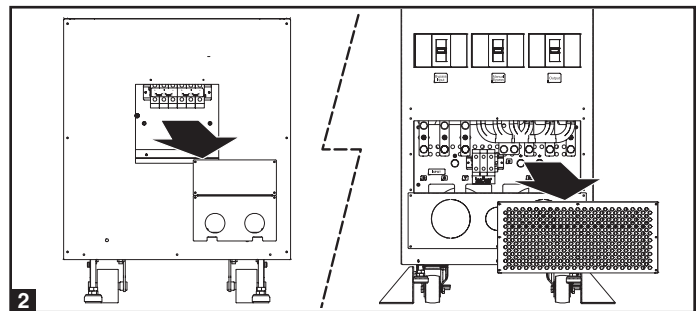
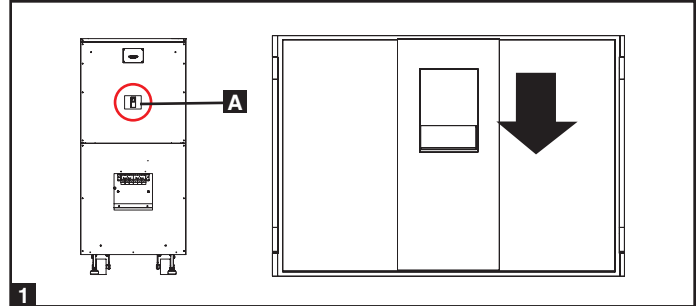

6-7 AC Input/Output Wiring (Single UPS)

1 After de-energizing all input and output (AC and DC) of the UPS system, remove the terminal block cover from the UPS system.

2 If you did not connect the ground cable in [Section 6-6](#), connect the UPS system's grounding terminal **A** to your facility's earth ground **B** with a 4 AWG (5.189 mm) ground cable. Keep the ground cable connected at all times after installation.

3 Remove the UPS system's front bezel to expose the circuit breaker. First, confirm that the main input circuit breaker switch **Q1** and the bypass input circuit breaker switch **Q2** are both off. Second, confirm that the manual bypass circuit breaker switch **Q3** is off. Third, confirm that the output circuit breaker switch **Q4** is off.

4 Confirm the phase of each cable, then connect the cables according to the UPS system terminal block diagram in [Section 6-3](#). See [Section 6-5](#) for cable size requirements. Cabling should be protected by flexible conduit and routed through the appropriate knockouts in the terminal block cover. **Warning: Observe proper phase rotation by connecting R to R, S to S, T to T and N to N. Failure to observe proper phase will damage the UPS system and create a risk of personal injury and property damage.**

5 Replace the UPS system's terminal block cover.

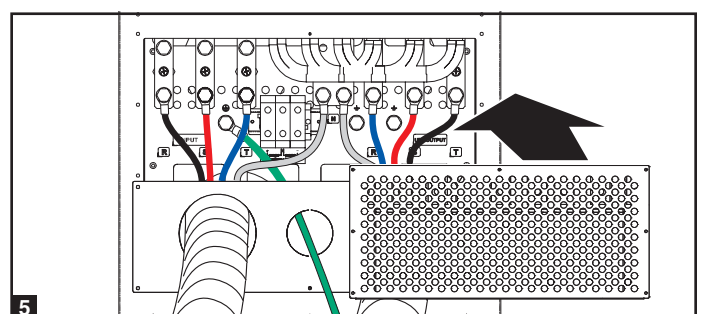
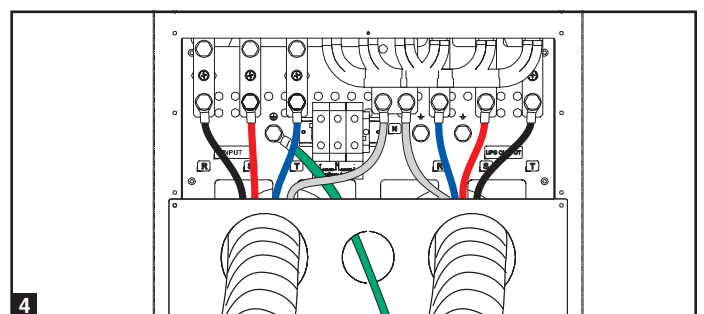
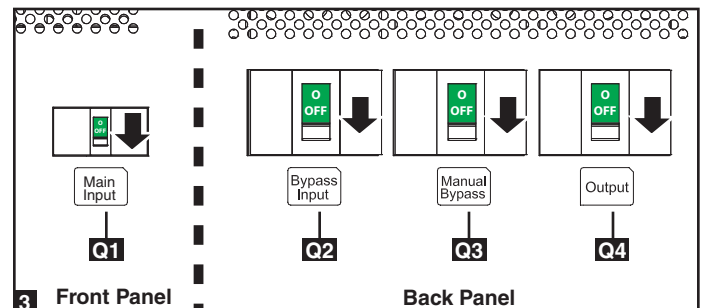
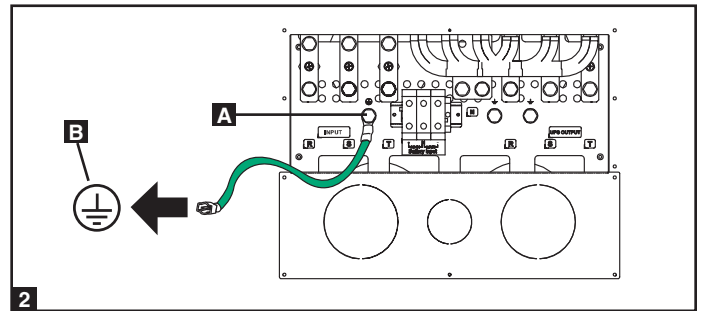
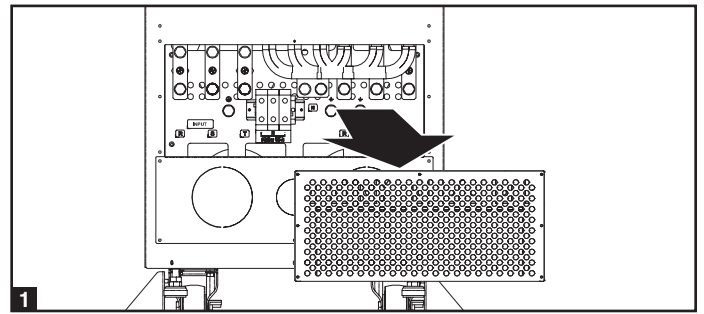

6-8 AC Input/Output Wiring (Parallel UPS – Single Input)

Parallel Configuration Warnings:

- The total input cable length must be equal to the total output cable length in order to prevent unbalanced load sharing between two UPS systems under reserve mode (i.e. $IP1 + OP1 = IP2 + OP2$; deviation must be $<10\%$).
- Parallel configuration only supports 2 UPS systems (1+1 redundancy). Do not attempt to link more than two UPS systems via parallel configuration.
- The UPS systems must have the same rating and capacity for parallel configuration installation. Attempting to link dissimilar UPS systems will damage the UPS systems and create a serious risk of personal injury and property damage.
- Each UPS must have its parallel group set to 2 and a different "Parallel ID" that indicates the UPS systems are being run in parallel. (See [Section 9-5-5](#) for details.)

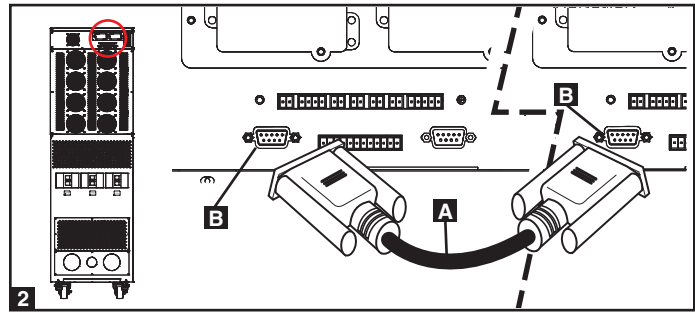
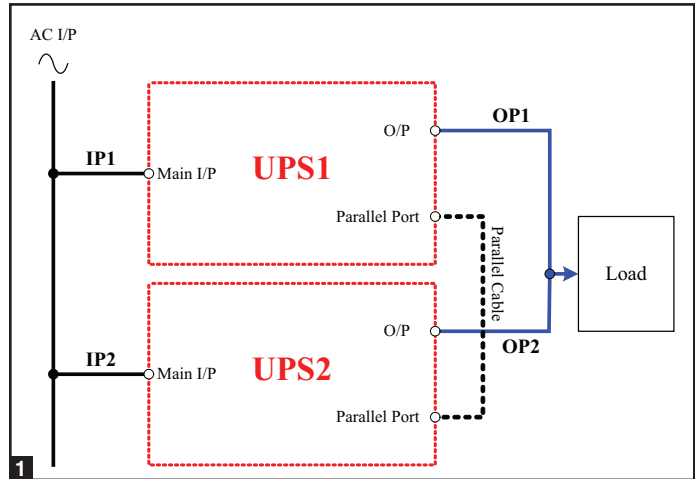

- 1 Follow the steps in [Section 6-7](#), wiring the UPS systems as shown in the diagram.
- 2 Connect the included parallel configuration cable **A** to the parallel configuration port **B** of each UPS system.

7 – Operating Modes

This section provides a basic description of the UPS system's operating modes. For more information about switching between operating modes, refer to [Section 8 – Start-Up, Shutdown and Bypass](#).

7-1 Online (Normal) Mode (Single UPS)

In online (normal) mode, the UPS system's rectifier converts incoming AC utility power to DC power that charges the batteries and supplies the inverter. The inverter transforms the DC power to precision-regulated, pure sine wave AC power that supports the operation of connected equipment. This dual conversion technology isolates connected equipment from all power problems and ensures that connected equipment receives ideal power at all times.

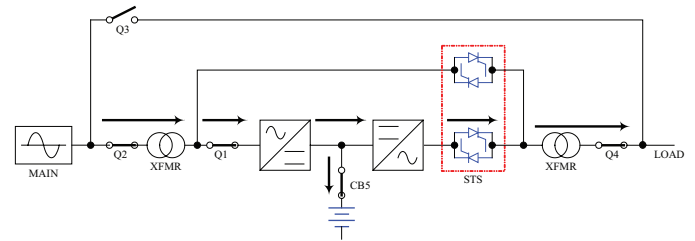

7-2 Battery Backup Mode (Single UPS)

When a blackout or other extreme power event occurs, the UPS system automatically switches from normal mode to battery backup mode. The UPS system's batteries (internal and/or external) provide emergency DC power to the inverter. The inverter transforms the DC power to precision-regulated, pure sine wave AC power that supports the operation of connected equipment.

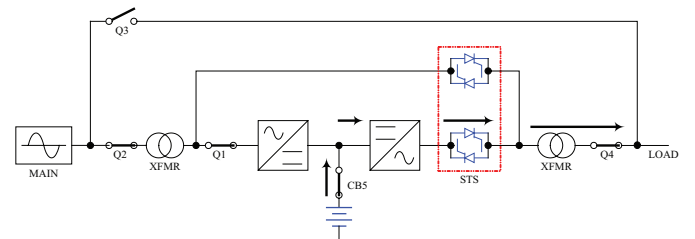

7-3 Auto Bypass Mode (Single UPS)

If the inverter malfunctions due to excessive temperature, overload, output short circuit, abnormal voltage or battery problems, the inverter will shut down. If the UPS system detects a bypass power source that conforms to normal parameters, then the UPS system automatically switches to auto bypass mode to continue supplying power to connected equipment. When all problems are eliminated, the UPS system switches back to online (normal) mode automatically.

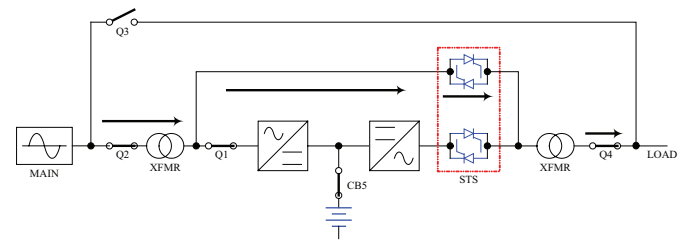

7-4 Manual Bypass Mode (Single UPS)

If UPS system maintenance or repair is required, you can bypass the UPS system and enable bypass power manually. After confirming that bypass power is present, stop the inverter by pressing the OFF button and answering "YES" to the question "Transfer to Bypass Mode?" (this transfers the UPS to static bypass) then switch the UPS system into manual bypass mode. (See [Section 8-5](#) for complete manual bypass procedure.) This allows service technicians to perform maintenance or repair jobs without interrupting the flow of AC power to connected equipment. **Warning: The UPS system must be de-energized completely before performing maintenance or repair by shutting it down completely after switching it to manual bypass mode.**

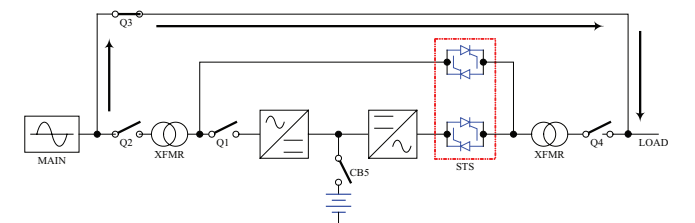

7 – Operating Modes (continued)

7-5 Online Mode (Parallel UPS)

Parallel redundancy (1+1) provides UPS system redundancy or increased total capacity. Under parallel redundancy, the total load is shared by two UPS systems. If one of the UPS systems malfunctions, the total connected equipment load is supported by the remaining UPS system. If the total load exceeds the capacity of the remaining UPS system, it will switch to auto bypass mode.

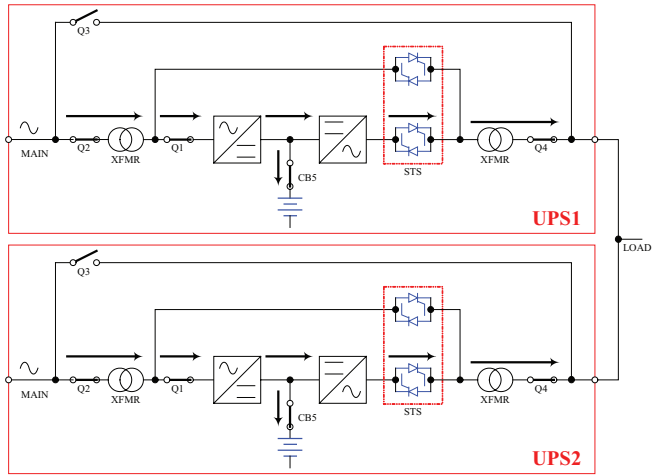

7-6 Battery Backup Mode (Parallel UPS)

Similar to on battery backup mode for a single UPS system (Section 7-2), except the total connected equipment load is shared by the parallel (1+1) UPS systems.

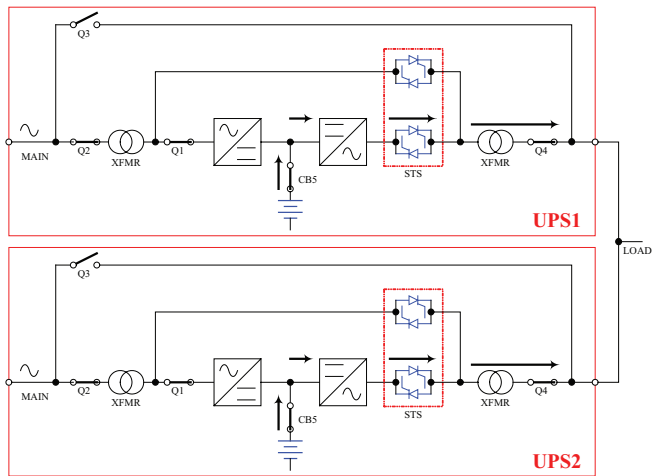

7-7 Auto Bypass Mode (Parallel UPS)

Similar to auto bypass mode for a single UPS system (Section 7-3), except with parallel (1+1) UPS systems.

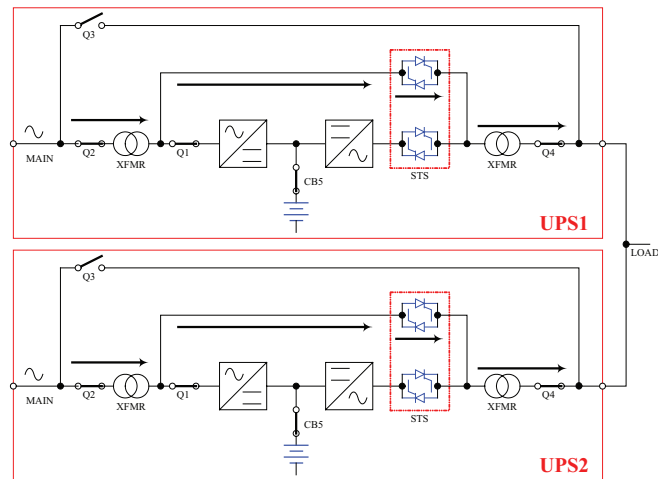

7-8 Manual Bypass Mode (Parallel UPS)

Similar to manual bypass mode for a single UPS system (Section 7-4), except with parallel (1+1) UPS systems. *Note: Both UPS systems must be switched into manual bypass mode.*

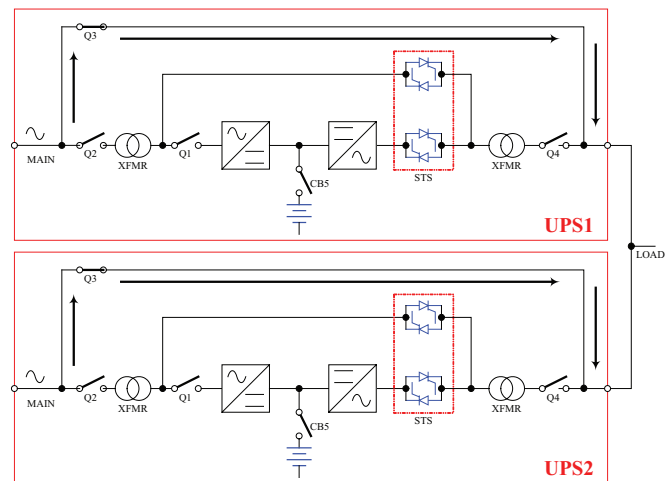

8 – Start-Up, Shutdown and Bypass

8-1 Control Panel and Breaker Diagrams

- A** “NORMAL” LED
- B** “BATTERY” LED
- C** “BYPASS” LED
- D** “FAULT” LED
- E** LCD Status Screen
- F** “ESC” (Escape) Button
- G** Scroll Buttons (▲ and ▼)
- H** Enter Button (↵)
- I** ON Button
- J** OFF Button
- K** “EPO” (Emergency Power Off) Button
- Q1** Main Input Circuit Breaker Switch
- Q2** Bypass Input Circuit Breaker Switch
- Q3** Manual Bypass Circuit Breaker Switch
- Q4** Output Circuit Breaker Switch

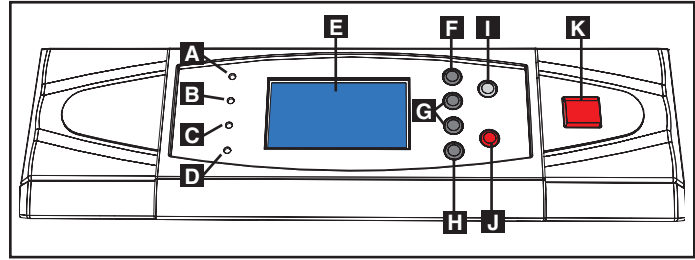

Control Panel

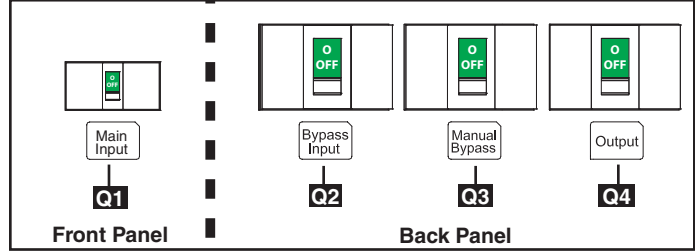

Circuit Breaker Switches

8-2 Preliminary Checklist (Single UPS)

- All circuit breaker switches should be off, including the breaker of the external battery cabinet (if present).
- Confirm that no voltage potential exists between Neutral and Ground.
- Confirm that the input power source matches the rating (voltage, frequency and phase) of the UPS system.

Note: After start-up, the UPS system will perform a brief self-test and display the results on the LCD screen. After a successful self-test, the UPS system will provide AC power to the connected equipment load.

8

8-3 Normal Start-Up Procedure (Single UPS)

- 1** If there is an external battery cabinet connected, switch on the circuit breaker **A** of the external battery cabinet.

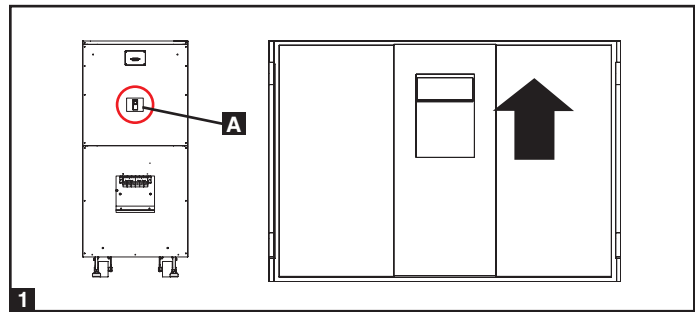

- 2** Confirm that the manual bypass circuit breaker switch **Q3** is off.

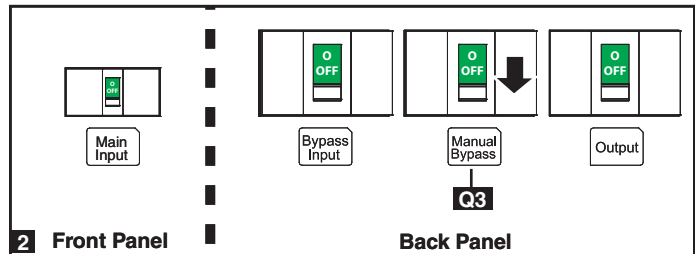

8 – Start-Up, Shutdown and Bypass (continued)

8-3 Normal Start-Up Procedure (Single UPS) (continued)

- Switch on the bypass input circuit breaker switch **Q2** then output circuit breaker switch **Q4**. After a brief initialization process, the LCD screen will show “ON AUTO BYPASS”, the “BYPASS” LED will illuminate and UPS system output will be supplied by the bypass power source.

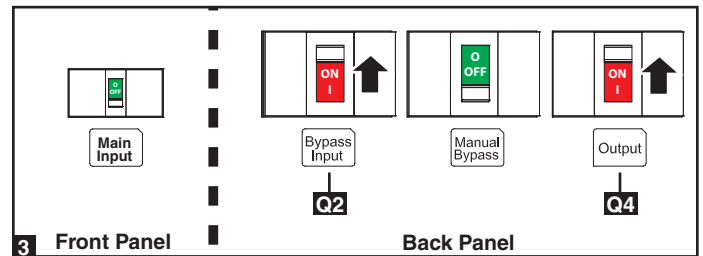

- Switch on the main input circuit breaker switch **Q1**. If the AC input power source is normal, the UPS system is ready for start-up.

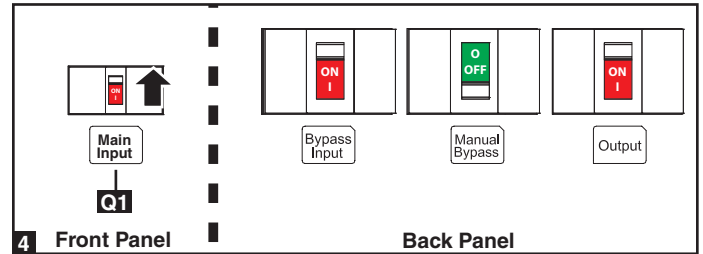

- Press the ON button **A** for 3 seconds (until you hear a beep), then release the button. The inverter will activate and synchronize with the bypass source, then automatically switch from auto bypass mode to online (normal) mode. The “BYPASS” LED will darken and the “NORMAL” LED will illuminate.

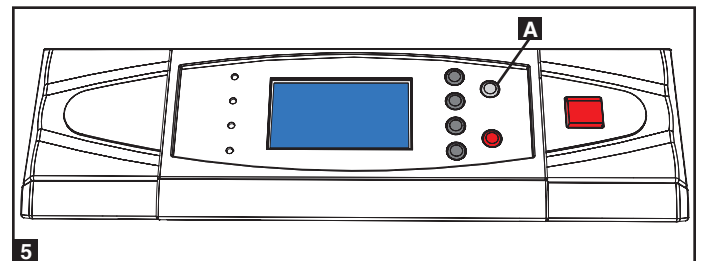

8-4 Battery Start-Up Procedure (Single UPS)

Note: The battery must be at least partially charged for this operation to succeed.

- If there is an external battery cabinet connected, switch on the circuit breaker **A** of the external battery cabinet.

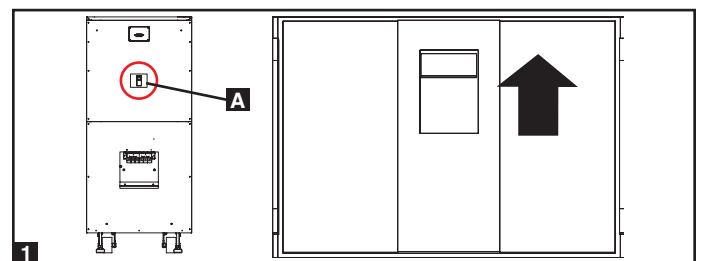

- Confirm that the manual bypass circuit breaker switch **Q3** is off.

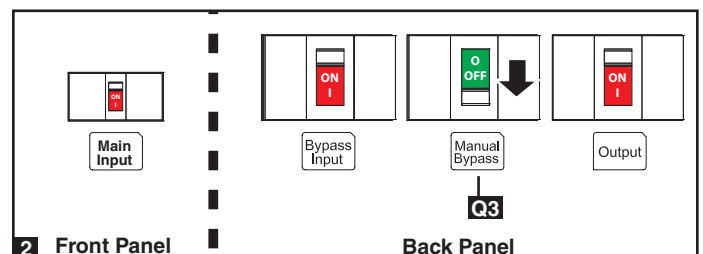

- Press the ON button **A** for 3 seconds (until you hear a beep), then release the button. The inverter will activate and use stored DC battery power to supply AC power to connected equipment. The “BATTERY” LED will illuminate.

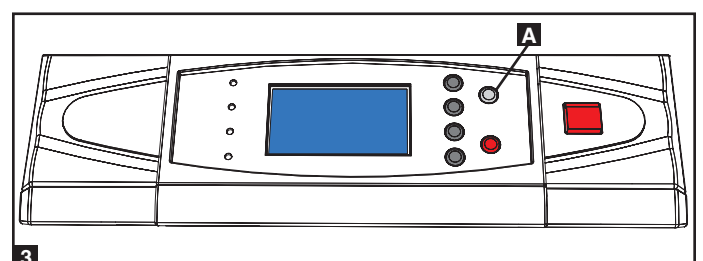

8 – Start-Up, Shutdown and Bypass (continued)

8-5 Manual Bypass Procedure (Single UPS)

Warning: Placing the UPS system in manual bypass will disable the inverter and power all loads from the manual bypass source, but the UPS system will still be energized. Before performing maintenance or repair on the UPS system, shut down and de-energize the UPS system completely by following the steps in Section 8-6. Although connected equipment loads will be powered by the bypass power source, they will not receive battery backup in the event of a utility power failure.

- 1 If the UPS is in NORMAL mode (green LED ON, LCD displays "Load Protected – On Line Mode"), then you must stop the inverter by pressing and holding the red OFF ("O") button **A** until the UPS beeps, then release the button and answer "YES" to the question "Transfer to Bypass Mode?". The UPS should transfer to Bypass.
- 2 Confirm the UPS is in BYPASS mode (amber Bypass LED is ON; LCD displays "Load Unprotected – On Auto Bypass"). Do not proceed if it is not in BYPASS mode.
- 3 Turn OFF the MAIN INPUT circuit breaker **Q1**.
- 4 Wait until the Power Module fans turn OFF (this may take a minute or two), then turn OFF the BATTERY BREAKER. On 80K units, the BATTERY BREAKER is on the back of the matching battery cabinet. *Note: Some external battery cabinets may have the BATTERY BREAKER behind the front door or elsewhere.*
- 5 Turn ON the MANUAL BYPASS circuit breaker **Q3**. The LCD will display "Load Unprotected – On Manual Bypass" and you will hear an audible alarm.
- 6 Turn OFF the OUTPUT circuit breaker **Q4**.
- 7 Turn OFF the BYPASS INPUT circuit breaker **Q2**. The unit's LCD will go blank after a few seconds.
- 8 The critical load is now supported by unconditioned utility power.

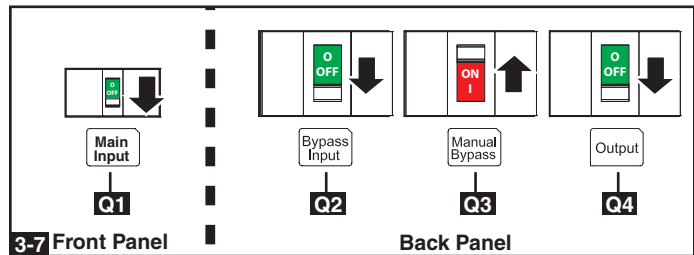
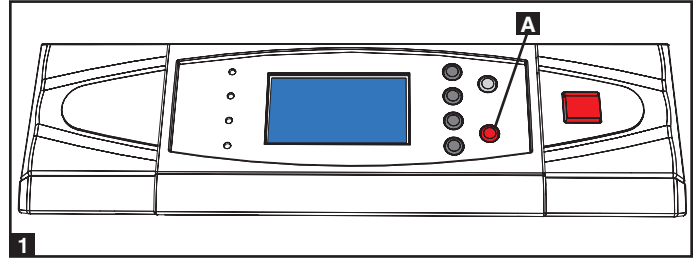

8

8-6 Shutdown Procedure (Single UPS)

Warning: The UPS system shutdown procedure will eliminate the AC power output for all loads. Before shutdown, confirm that all loads are turned off or place the UPS system in manual bypass mode to keep loads powered by the bypass power source.

- 1 If the UPS is in NORMAL mode (green LED ON, LCD displays "Load Protected-On Line Mode"), then you must stop the inverter by pressing and holding the red OFF ("O") **A** button until the UPS beeps, then release the button. The UPS should transfer to Bypass.
- 2 Confirm the UPS is in Bypass (amber Bypass LED is ON; LCD displays "Load Unprotected-On Auto Bypass"). Do not proceed if it is not on Bypass.
- 3 Turn OFF the OUTPUT circuit breaker **Q4**.
- 4 Turn OFF the MAIN INPUT circuit breaker **Q1**.
- 5 Turn OFF the BYPASS INPUT circuit breaker **Q2**.
- 6 Wait until the Power Module fans power OFF and the LCD goes blank (this may take a minute or two), then turn OFF the BATTERY BREAKER on the back of the battery cabinet.

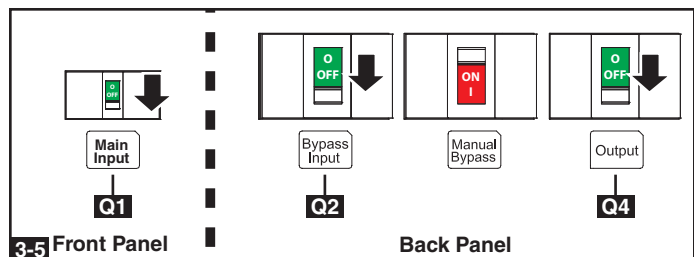
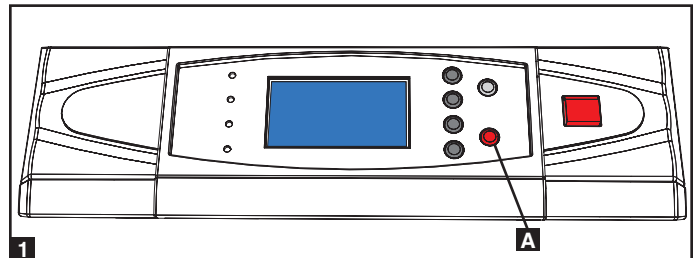

8-6 Shutdown Procedure (Single UPS) (continued)

Note: If the UPS system remains off for an extended period of time, it should be turned on periodically to allow the batteries to recharge. The UPS system should be turned on and the batteries should be recharged at least one uninterrupted 24-hour period every 3 months. Failure to recharge the batteries periodically may cause irreversible battery damage.

Transfer critical load to NORMAL from MANUAL BYPASS

- 1** Confirm the UPS is on MANUAL BYPASS (the MANUAL BYPASS circuit breaker **Q3** is ON; the OUTPUT **Q4**, BYPASS INPUT **Q2** and MAIN INPUT **Q1** circuit breakers are OFF).
- 2** Turn ON the BATTERY BREAKER on the back of the battery cabinet.
- 3** Turn ON the BYPASS UNIT circuit breaker **Q2**. The amber Bypass LED should come ON and the LCD will display "Load Unprotected-On Manual Bypass".
- 4** Confirm the amber BYPASS LED is ON. Do not proceed if it is not ON.
- 5** Turn ON the OUTPUT circuit breaker **Q4**.
- 6** Turn OFF the MANUAL BYPASS circuit breaker **Q3**. The LCD will display "Load Unprotected-On Auto Bypass".
- 7** Turn ON the MAIN INPUT circuit breaker **Q1**. The Power Module fans will turn ON.
- 8** Press and hold the green ON ("1") button until the UPS beeps, then release the button. The UPS will perform its self-test diagnostics and the LCD will display "Self Diagnosis". After the UPS self-test is completed, the UPS will transfer to NORMAL mode (green LED ON, LCD displays "Load Protected-On Line Mode").
- 9** Confirm there are no active alarms present ("!" on the display and audible beeping). If an alarm is present, press the UP or DOWN arrows to display the active alarm. Correct the action as required.
- 10** Scroll through the Measure Menu and confirm all input and output power readings are within the recommended specifications.
- 11** If any problems are noted, contact your technical support personnel for further assistance.
- 12** The critical load is now supported by conditioned battery back-up power.

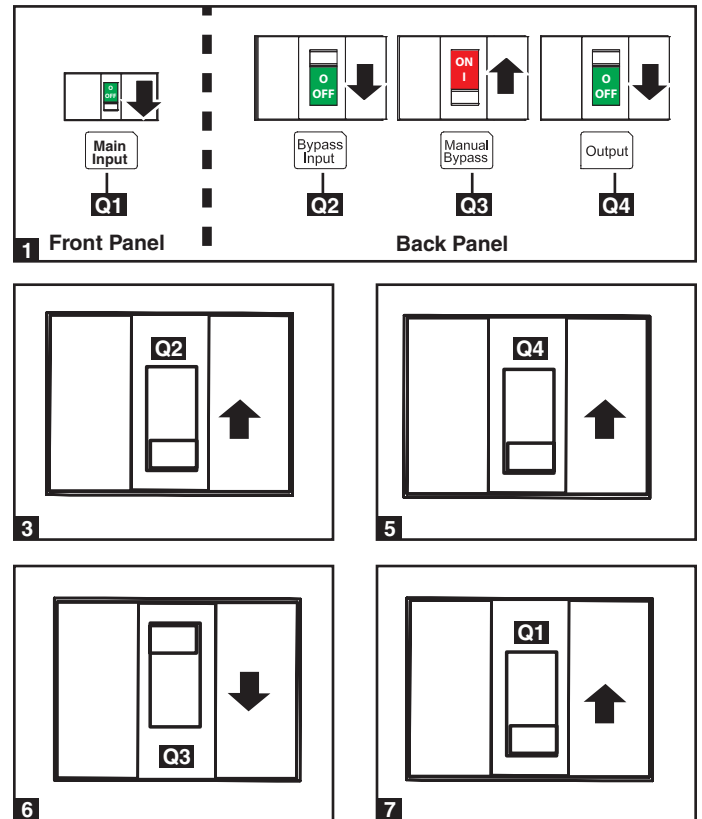

8-7 Preliminary Checklist (Parallel UPS)

Warning: Parallel configuration requires exactly two UPS systems (1+1 configuration). Do not attempt to link more than two UPS systems via parallel configuration. The UPS systems must have the same rating, capacity and system/power module firmware version for parallel configuration installation. Attempting to link dissimilar UPS systems will damage the UPS systems and create a serious risk of personal injury and property damage.

- All circuit breaker switches should be off, including the breakers of the external battery cabinets.
- Confirm that no voltage potential exists between Neutral and Ground.
- Confirm that the input power source matches the rating (voltage, frequency and phase) of the UPS systems.
- **Each UPS must have its parallel group set to 2 and a different "Parallel ID" that indicates the UPS systems are running in parallel. (See Section 9-5-5 for more details.)**

Note: After start-up, the UPS systems will perform a brief self-test and display the results on the LCD screen. After a successful self-test, the UPS systems will provide AC power to the connected equipment load.

8-8 Start-Up Procedure (Parallel UPS)

1 Connect the parallel configuration cable **A** to the DB9 parallel redundancy port **B** of each UPS system. *Note: Before starting up parallel UPS systems, ensure the "Parallel ID" is different for each UPS and that the parallel group is set. (See section 9-5-5.)*

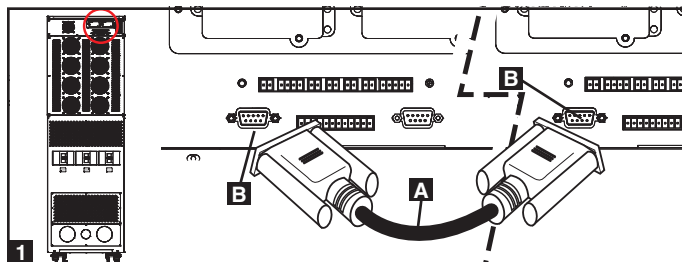

2 If the UPS systems have external battery cabinets connected, switch on the external battery cabinet circuit breaker switch **A** of each battery pack.

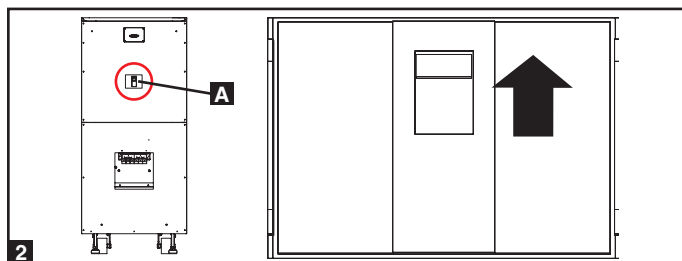

3 Switch on the bypass input circuit breaker switch **Q2** of each UPS system. After a brief initialization process, the LCD screen will show "ON AUTO BYPASS" and the "BYPASS" LED will illuminate.

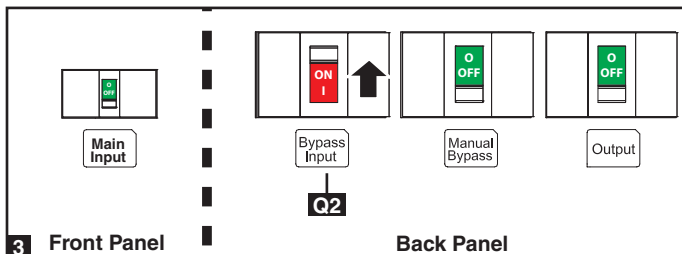

4 Switch on the main input circuit breaker switch **Q1** of each UPS system.

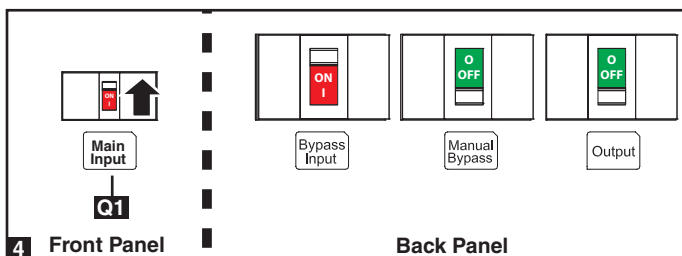

5 Press the ON button **A** of one of the UPS systems for 3 seconds (until you hear a beep), then release the button. The inverter will activate and synchronize with the bypass source. Press the ON button for the other UPS system for 3 seconds (until you hear a beep), then release the button. When the inverter of each UPS system is operating normally, they will automatically switch from auto bypass mode to online (normal) mode at the same time. The "BYPASS" LED will darken and the "NORMAL" LED will illuminate.

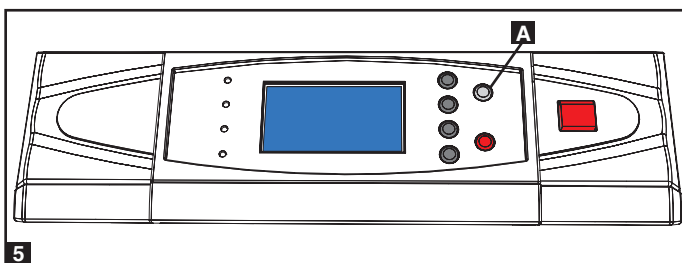

6 Check the output voltage of each UPS system. The phase deviation between each UPS system should be less than 5V. If the phase deviation is within the acceptable range, switch on the output circuit breaker switch **Q4** of each UPS system. *Note: For more information on checking the output voltage of each UPS system, see Section 9-4.*

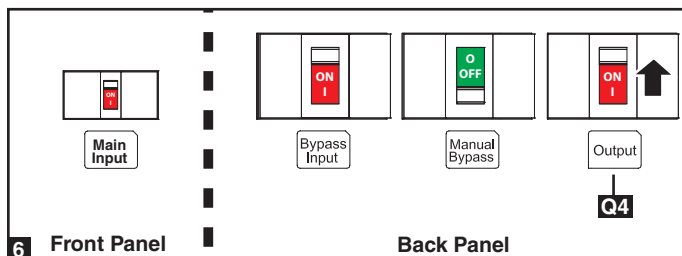

8-9 Shutdown Procedure (Parallel UPS)

Warning: The UPS system shutdown procedure will eliminate the AC power output for all loads. Before shutdown, confirm that all loads are turned off or place the UPS systems in manual bypass mode to keep loads powered by the bypass power source.

- 1 For the UPS system you wish to shut down, press the OFF button **A** for 3 seconds (until you hear a beep), then release the button. If the other UPS system can support the connected equipment loads alone, the UPS system that was turned off will shut down its inverter and its LCD screen will read “LOAD NOT POWERED”. The other UPS system’s LCD screen will read “ONLINE MODE”. If the total connected equipment load is too large to be handled by a single UPS system, both UPS systems will shut down their inverters and switch to bypass mode, and their LCD screens will read “ON AUTO BYPASS”.
- 2 For the UPS system you wish to shut down, switch off the main input circuit breaker switch **Q1**, then switch off the output circuit breaker switch **Q4**.
- 3 For the UPS system you wish to shut down, switch off the bypass input circuit breaker switch **Q2**.
- 4 When the UPS system is completely shut down, the LCD screen will be completely off. If the UPS systems have external battery cabinets connected, switch off the external battery cabinet circuit breaker switch **A** of each battery pack.

Note: If the UPS system remains off for an extended period of time, it should be turned on periodically to allow the batteries to recharge. The UPS system should be turned on and the batteries should be recharged at least one uninterrupted 24-hour period every 3 months. Failure to recharge the batteries periodically may cause irreversible battery damage.

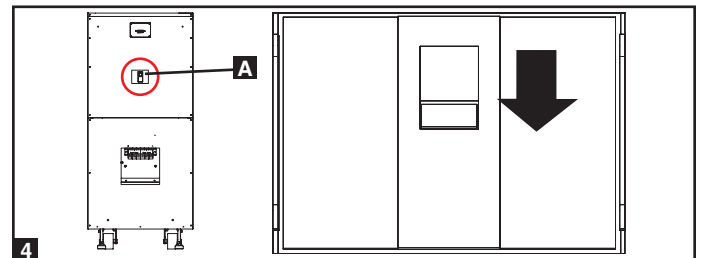
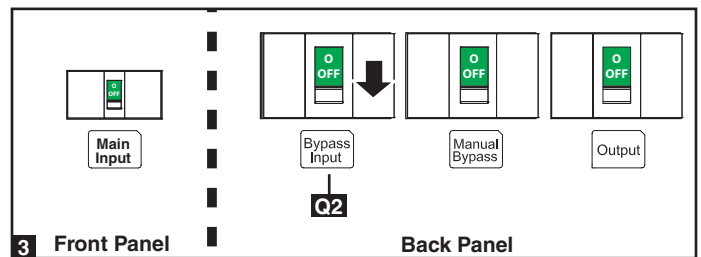
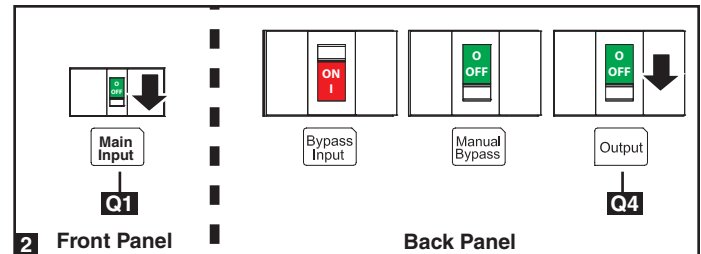
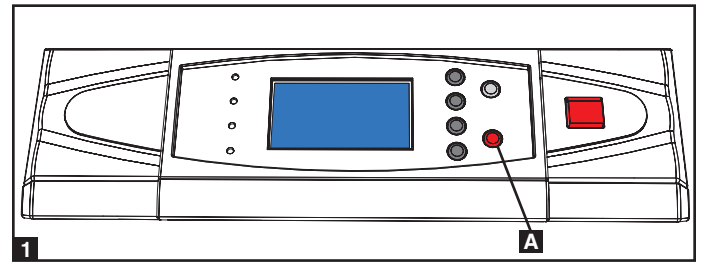

8 – Start-Up, Shutdown and Bypass (continued)

8-10 Manual Bypass Procedure (Parallel UPS)

Warning: When the UPS system is in manual bypass, the inverter shuts down. Connected equipment loads are powered by the bypass power source and will not receive battery backup during a utility power failure.

1 For the first UPS system you wish to shut down, press the OFF button **A** for 3 seconds (until you hear a beep), then release the button. If the other UPS system can support the connected equipment loads alone, the UPS system that was turned off will shut down its inverter and its LCD screen will read “LOAD NOT POWERED”. The other UPS system’s LCD screen will read “ONLINE MODE”. If the total connected equipment load is too large to be handled by a single UPS system, both UPS systems will shut down their inverters and switch to bypass mode, and their LCD screens will read “ON AUTO BYPASS”. Repeat step 1 for the second UPS system you wish to shut down.

2 Switch off the main input circuit breaker switch **Q1** of each UPS system.

3 Confirm that both UPS systems are shut down, then switch on the manual bypass circuit breaker switch **Q3** of each UPS system. The bypass power source will power the loads and the LCD screen will read “ON MANUAL BYPASS”.

4 Switch off the bypass input circuit breaker switch **Q2** and the output circuit breaker switch **Q4** of each UPS system. The LCD screen will turn off completely.

5 If the UPS systems have external battery cabinets connected, switch off the external battery cabinet circuit breaker switch **A** of each battery pack.

6 In this mode, only the manual bypass path (including the manual bypass circuit breaker **Q3**, the load terminals of the output circuit breaker switch **Q4** and the terminal block **B**) contain hazardous voltage, allowing qualified service personnel to perform maintenance or repair. *Note: Qualified service personnel may prefer to de-energize the UPS systems completely, depending on local codes and the nature of the maintenance or repair.*

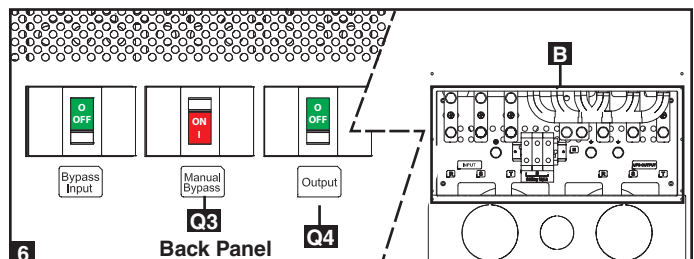
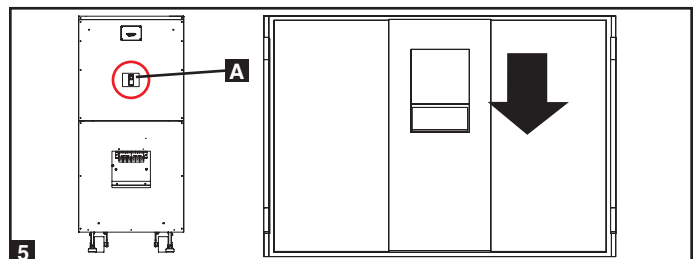
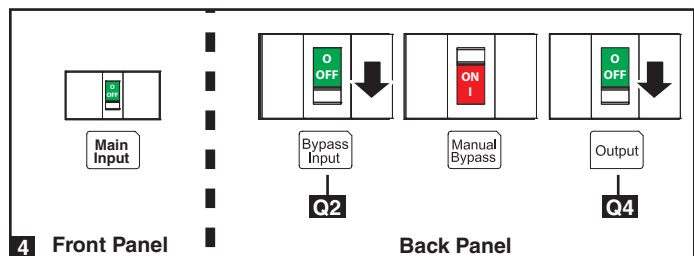
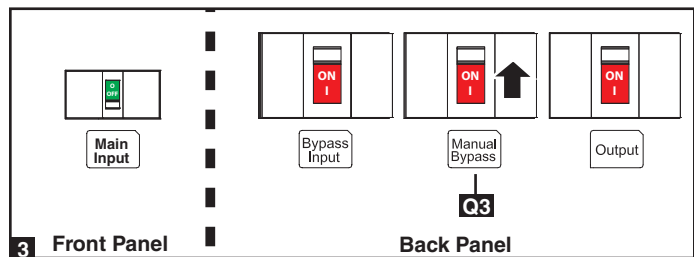
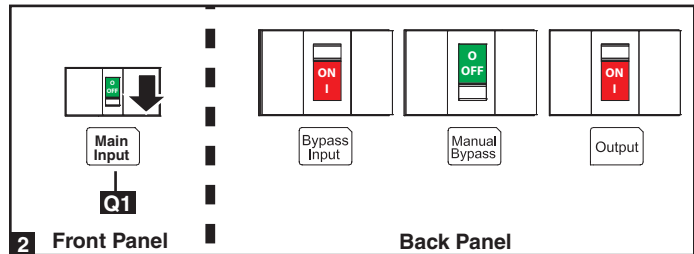
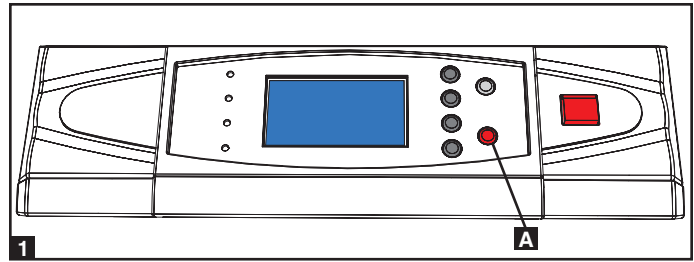

8 – Start-Up, Shutdown and Bypass (continued)

8-11 Switching from Manual Bypass to Normal Mode (Parallel UPS)

- 1** If the UPS systems have external battery cabinets connected, switch on the external battery cabinet circuit breaker switch **A** of each battery pack.
- 2** Switch on the bypass input circuit breaker switch **Q2** and the output circuit breaker switch **Q4** of each UPS system.
- 3** Confirm that the LCD screens of both UPS systems read “ON MANUAL BYPASS”, then switch off the manual bypass circuit breaker switch **Q3** of each UPS system. The LCD screen will read “ON AUTO BYPASS”.
- 4** Switch on the main input circuit breaker switch **Q1** of each UPS system.
- 5** Press the ON button **A** of the first UPS systems for 3 seconds (until you hear a beep), then release the button. Press the ON button for the second UPS system for 3 seconds (until you hear a beep), then release the button. When the inverter of each UPS system is operating normally, they will switch to online (normal) mode at the same time.

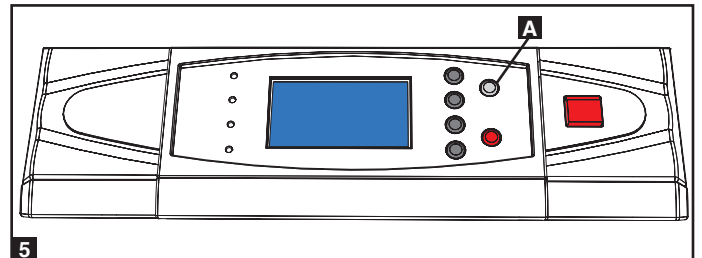
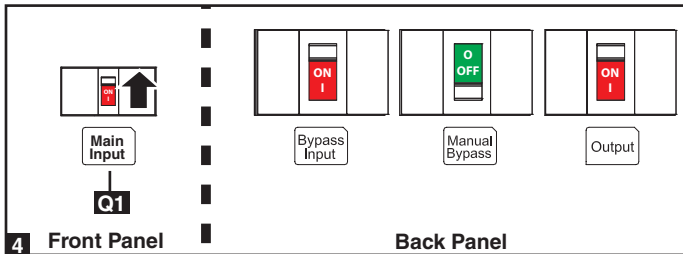
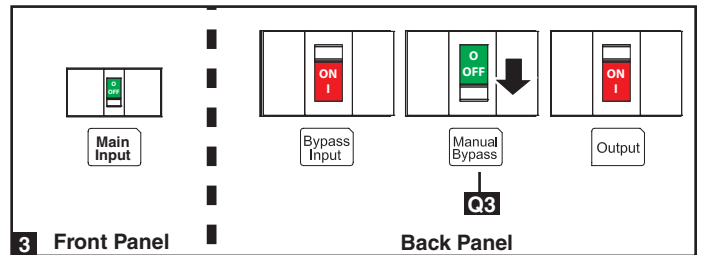
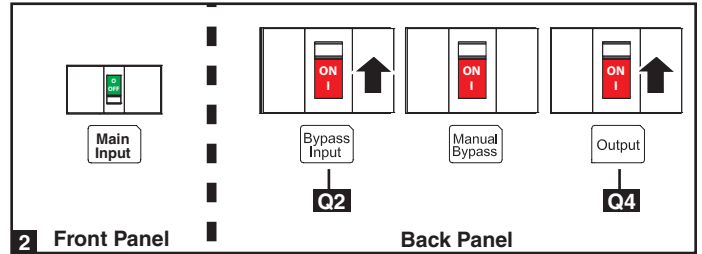
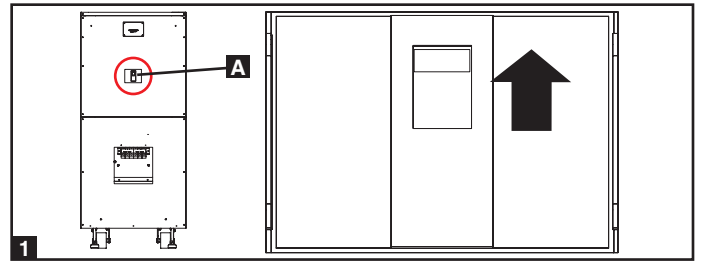

9 – Display and Configuration

9-1 Control Panel Diagram

- A** “NORMAL” (Green) LED: Illuminated when the UPS input power is normal.
- B** “BATTERY” (Amber) LED: Illuminated when the UPS is in battery back-up mode.
- C** “BYPASS” (Amber) LED: Illuminated when the UPS is in manual bypass mode.
- D** “FAULT” (Red) LED: Illuminated when any fault occurs.
- E** LCD Status Display: Multi-language display.
- F** “ESC” (Escape) Button: Escape/Page Up.
- G** Scroll Buttons (▲ and ▼): Scroll cursor up or down.
- H** Enter Button (↵): Enter/Confirm Settings.
- I** ON Button: Press and hold for 3 seconds to start-up the UPS (turns Inverter ON).
- J** OFF Button: Press and hold for 3 seconds to power OFF the UPS (turns Inverter OFF).
- K** “EPO” (Emergency Power Off) Button: Pressing the EPO button will completely remove power from the UPS output.

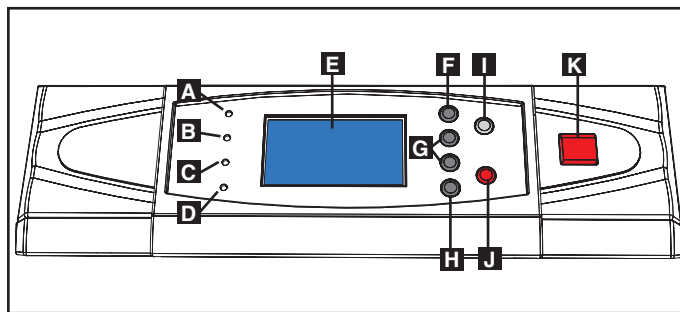

Control Panel

9-2 Display Hierarchy

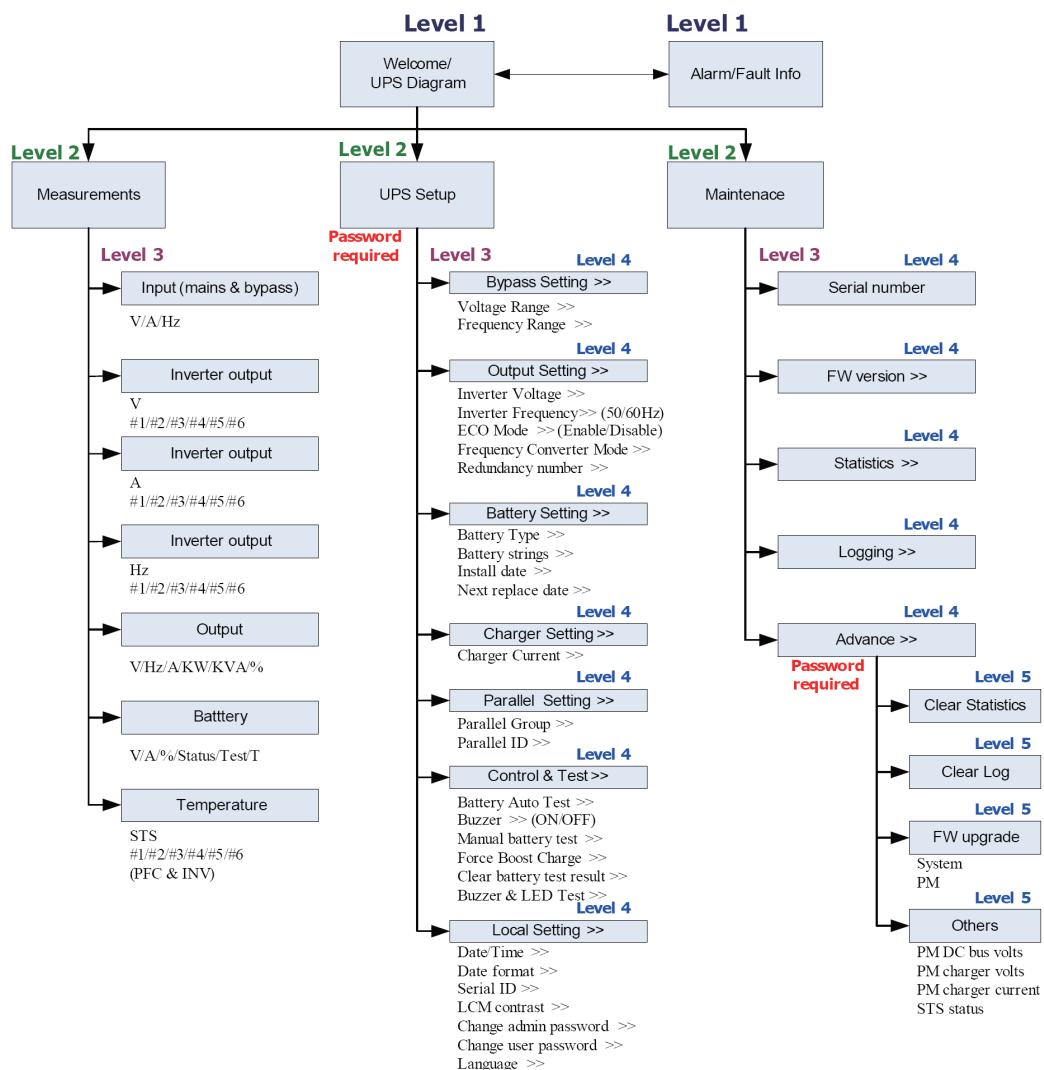

9-3 Default Display

- After the UPS system starts up and completes the self-test, the LCD status screen will show the default display. The default display includes a status message and diagram that shows the operational status of the UPS system.

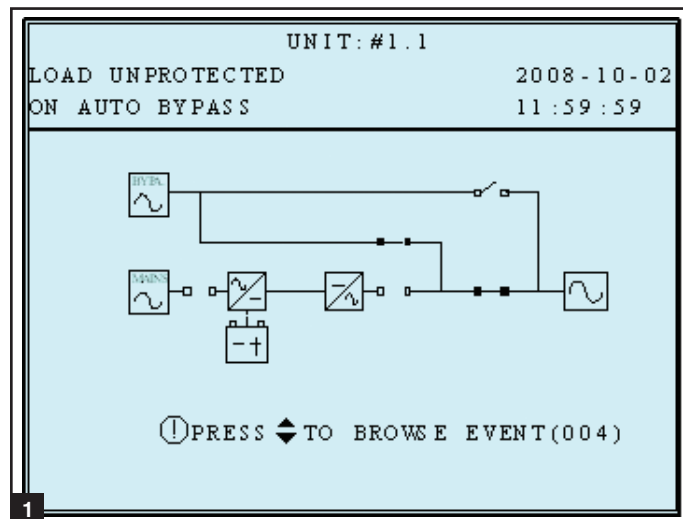

When any event occurs, you will see the sign “!” flashes. You can press “▼” to see the details. For example:

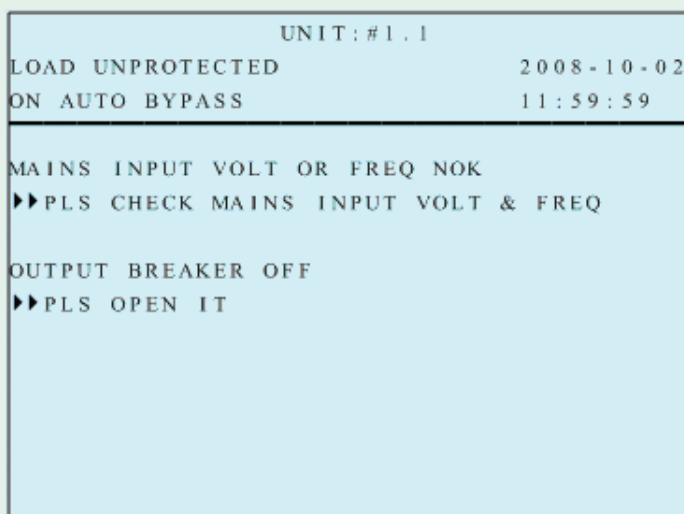

Press “▼” again to go to the next message. If there is no further message, the screen will return to the default screen.

9-3-1 Status Display

- The UPS system output is off and the connected equipment loads are not powered. This condition may be due to automatic UPS shutdown or manually switching off the output circuit breaker switch.

Possible causes:

- The UPS automatically shuts down by itself.
- Manually switch off the output circuit breaker.

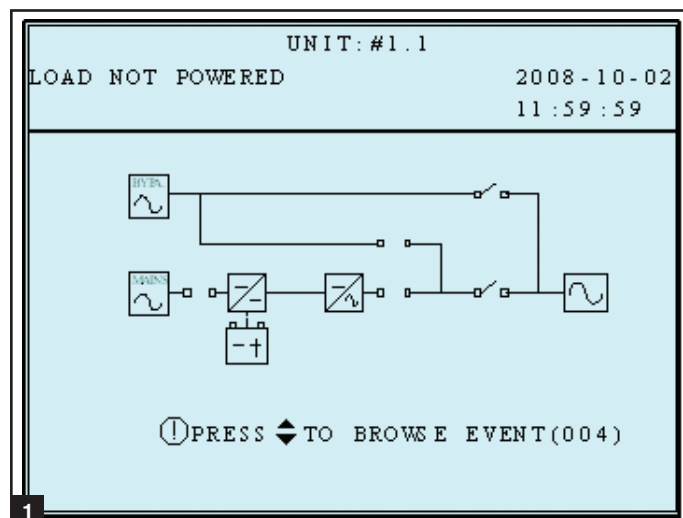

9 – Display and Configuration (continued)

9-3-1 Status Display (continued)

- 2 The loads are supplied by bypass source due to initial startup of the UPS.

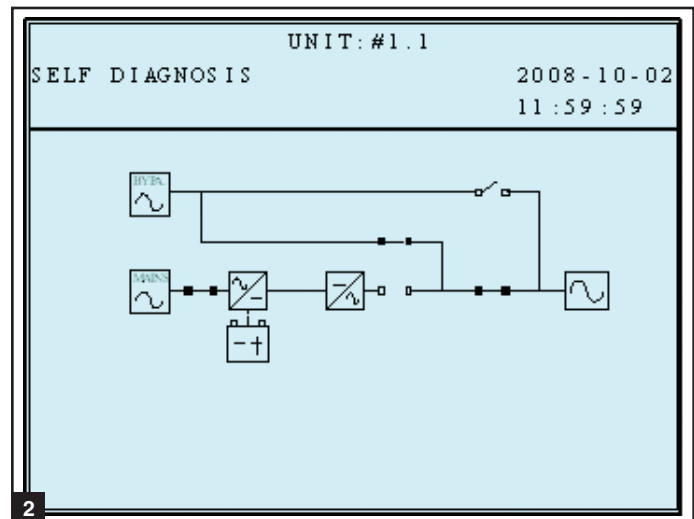

- 3 The UPS is starting up by battery power.

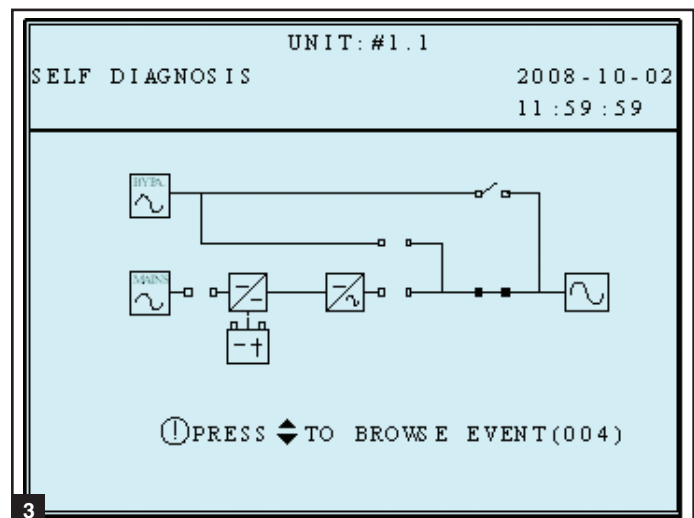

- 4 The UPS system is in auto bypass mode. Connected equipment loads will lose power if the bypass power source fails.

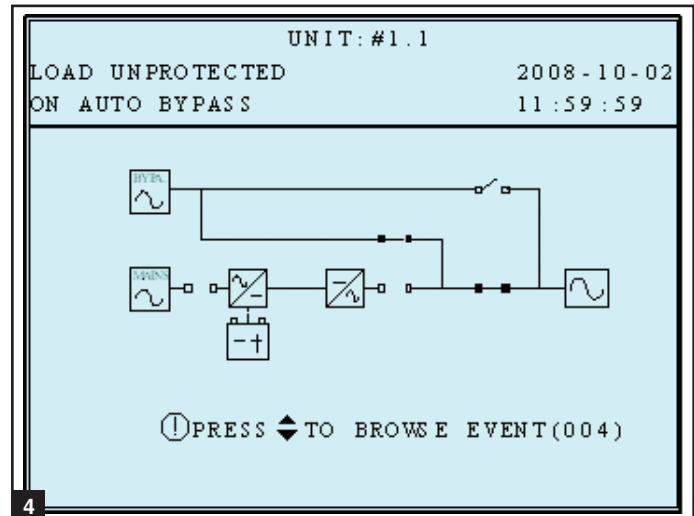

9 – Display and Configuration (continued)

9-3-1 Status Display (continued)

- 5** The UPS system is operating in online (normal) mode. Connected equipment loads will receive battery backup power if the mains (utility or generator) power source fails.

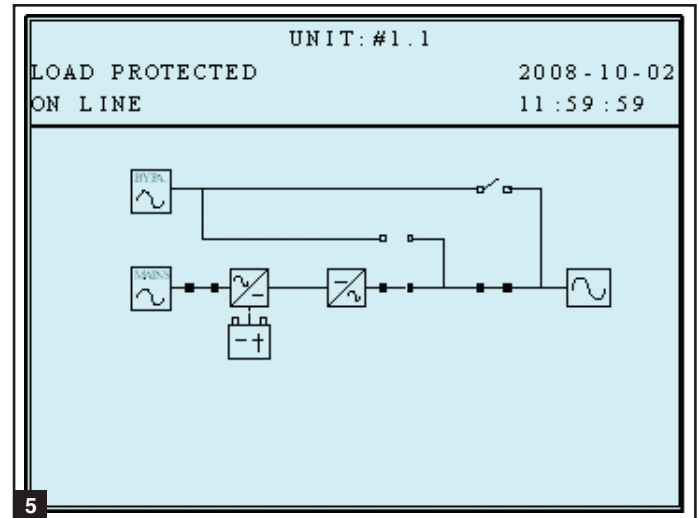

- 6** The UPS is in battery backup mode. The loads are supplied by battery power.

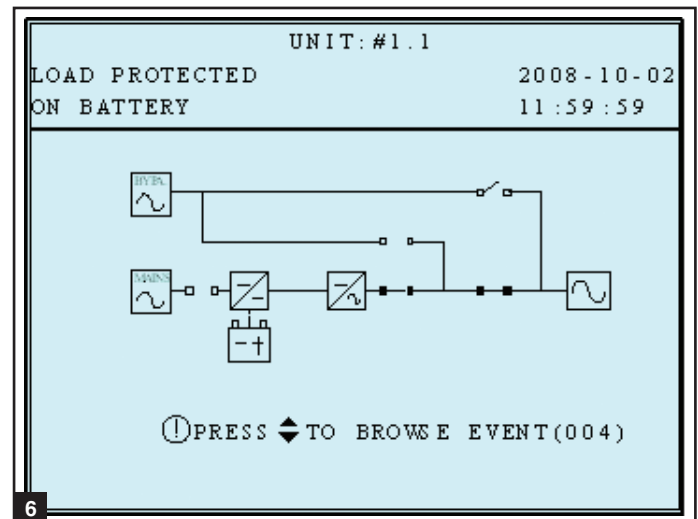

- 7** The UPS is performing the “battery test”.

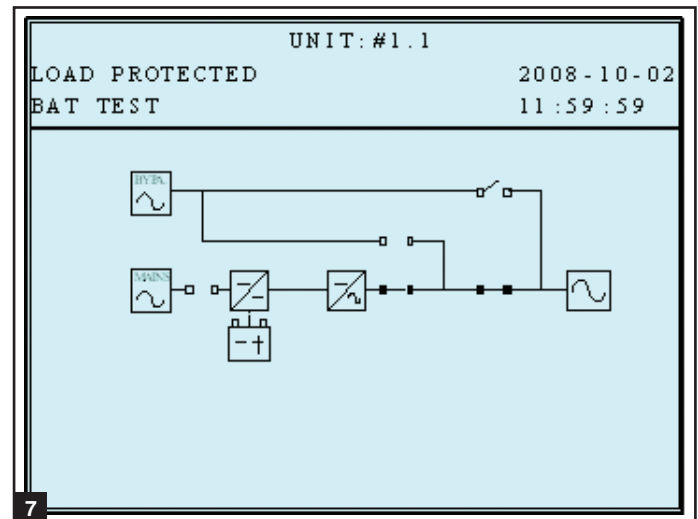

9 – Display and Configuration (continued)

9-3-1 Status Display (continued)

- 8 The UPS system is operating in economy mode, and connected equipment loads are being powered by the bypass source.

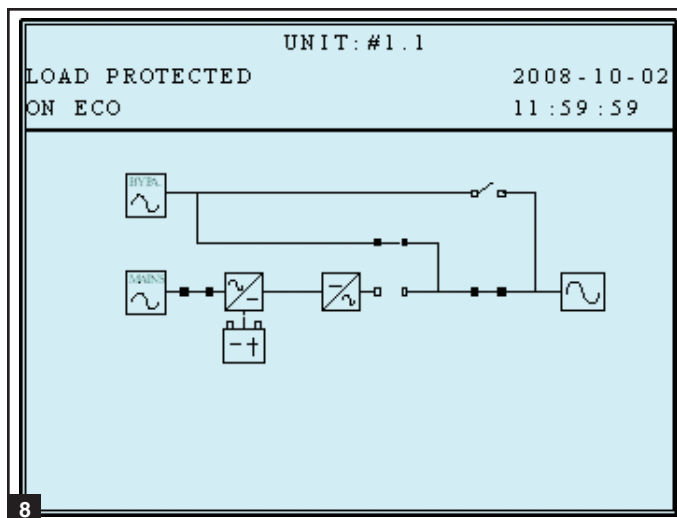

- 9 The UPS system is in manual bypass mode in order to allow qualified service personnel to perform maintenance or repair on the UPS system. Connected equipment loads will lose power if the bypass power source fails.

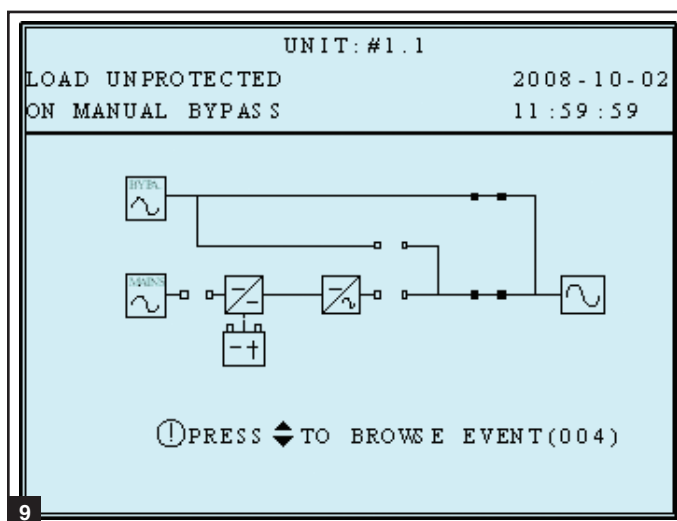

9-4 Main Menu

From the default display, press the enter button (↵) to access the main menu. Press the scroll down button (▼) or the scroll up button (▲) to move the cursor. Press the enter button (↵) to select one of the available menu options.

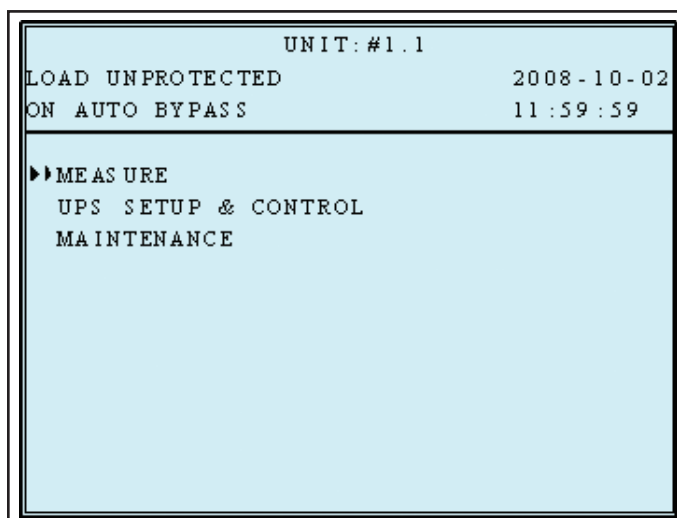

9 – Display and Configuration (continued)

9-4 Main Menu (continued)

UPS System “Measure Menu

1. Press the enter button (↵) to select “MEASURE” from the main menu.
2. Use the scroll buttons (▲ or ▼) to scroll through the available data screens. Press the “ESC” button to return to the previous menu.

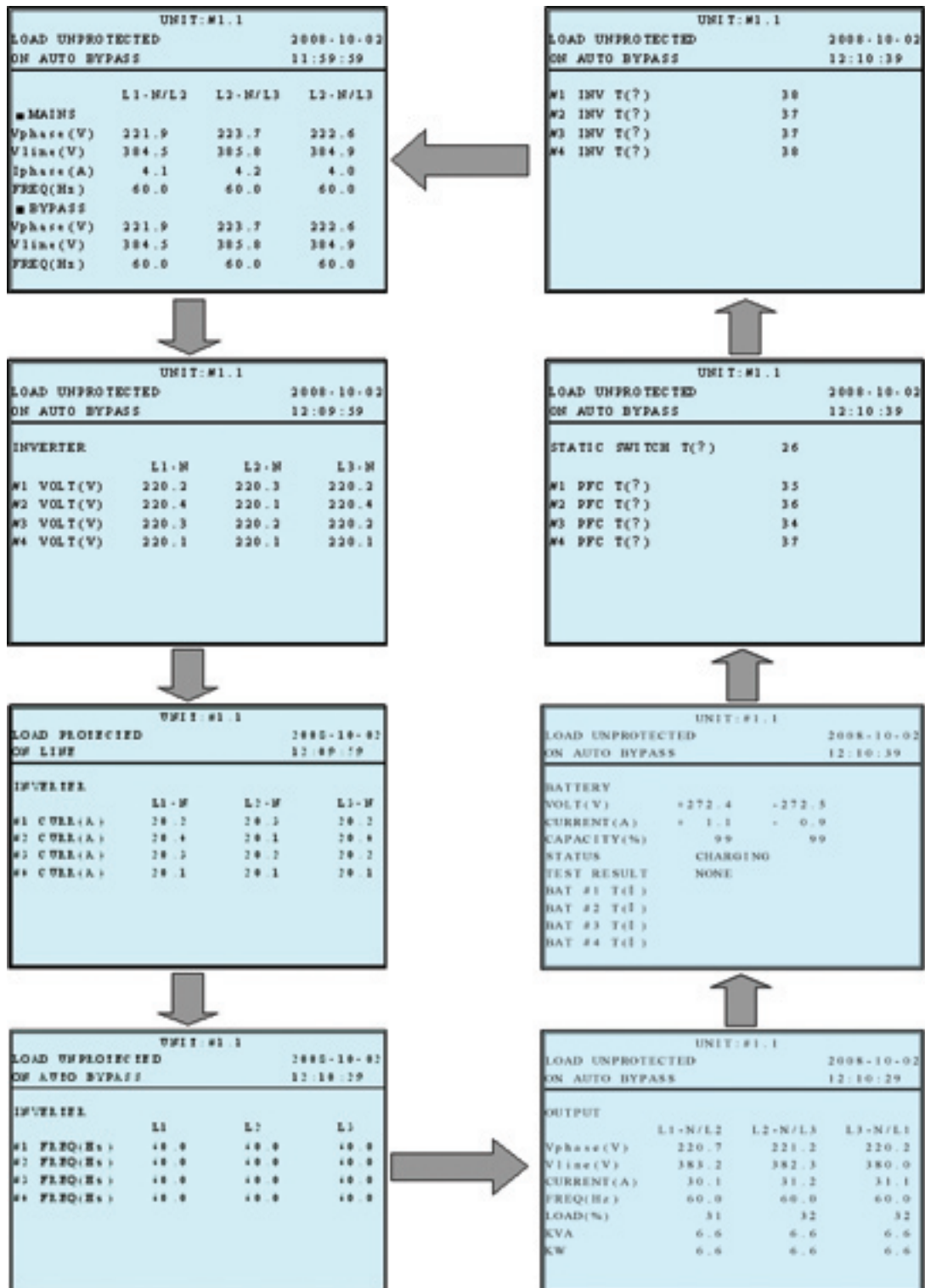

9-5 UPS Setup

Before changing the setting of each SETUP, you have to login first.

```
UNIT: #1.1
LOAD UNPROTECTED      2008-10-02
ON AUTO BYPASS        12:09:49

▶▶ BYPASS
   OUTPUT
   BATTERY
   CHARGER
   PARALLEL
   CONTROL & TEST
   LOCAL
```

- 1 Accessing the UPS system setup menu requires a password. From the login screen, press the enter button (↵) to select whether to log in as an administrator or user.

ADMINISTRATOR:

Qualified service personnel

User:

The authorization is only to check the parameter but not to configure.

```
UNIT: #1.1
LOAD UNPROTECTED      2008-10-02
ON AUTO BYPASS        11:59:59

LOGIN
▶▶ ADMIN IS TRATOR    0000
   USER              0000
```

1

- 2 The password consists of 4 numerals. Press the scroll down button (▼) or the scroll up button (▲) to select the first numeral, then press the enter button (↵) to enter the numeral choice. After entering the last numeral, press the enter button (↵) to confirm the password choice. The default user password is 0000. The default administrator password is 0000. Only qualified service personnel should have access to the administrator password.

```
UNIT: #1.1
LOAD UNPROTECTED      2008-10-02
ON AUTO BYPASS        11:59:59

LOGIN
▶▶ ADMIN IS TRATOR    0000
   USER              0000
```

2

9-5 UPS Setup (continued)

- 3 If the password is wrong, press "←" to reselect.

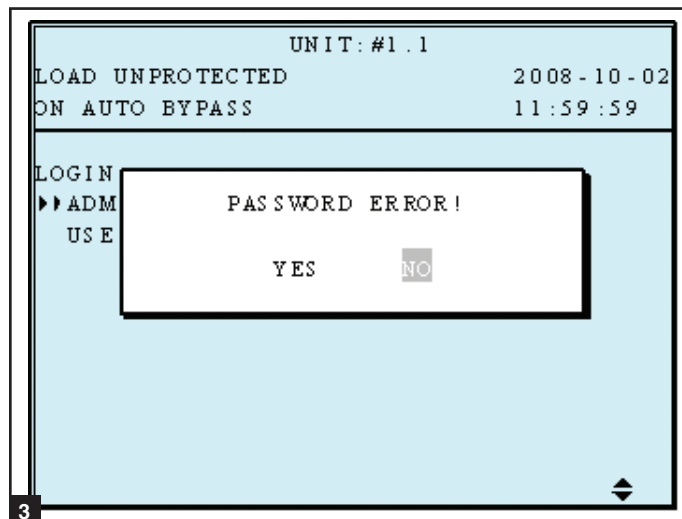

9-5-1 Bypass Setup

- 1 Enter the UPS system setup menu. Use the scroll buttons (▲, ▼) to move the cursor to "BYPASS SETUP", then press the enter button (↵).

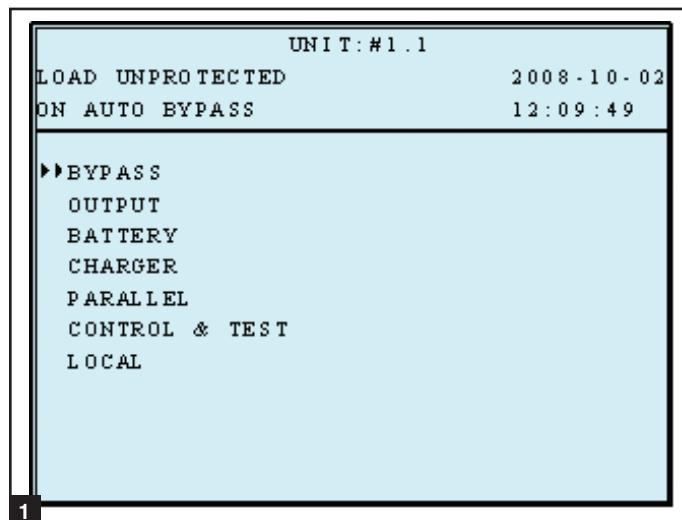

- 2 From the "VOLTAGE RANGE" screen, use the scroll buttons (▲, ▼) to select a bypass voltage range and press the enter button (↵) to confirm the setting.

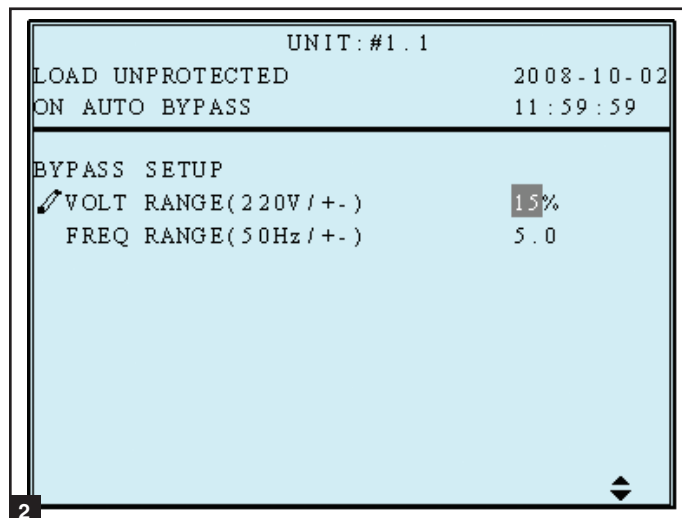

9 – Display and Configuration (continued)

9-5-1 Bypass Setup (continued)

- From the “FREQUENCY RANGE” screen, use the scroll buttons (▲,▼) to select a bypass frequency range and press the enter button (↵) to confirm the setting.

Note: Press the “ESC” button to return to the previous menu.

Press “ESC” to return to the “UPS SETUP” menu.

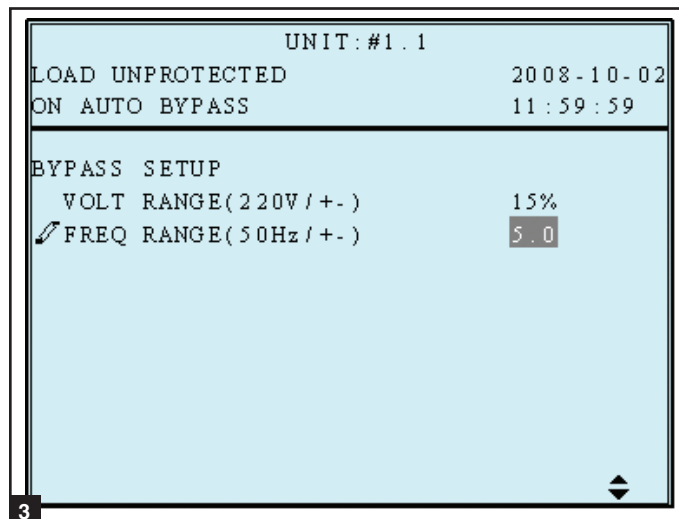

9-5-2 Output Setup

Use “▲” or “▼” to select “OUTPUT SETUP”, then press “↵” to confirm.



All parameters in this segment can only be changed when UPS is in “Bypass Mode”.

- Enter the UPS system setup menu. Use the scroll buttons (▲,▼) to move the cursor to “OUTPUT SETUP”, then press the enter button (↵).

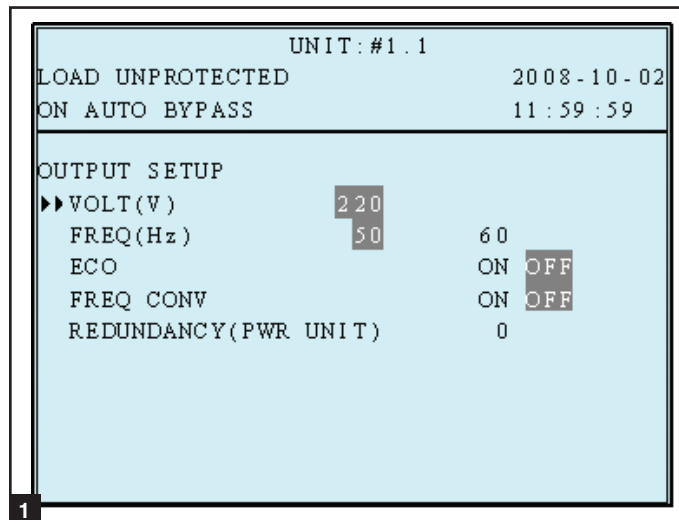

9-5-2 Output Setup (continued)

2 Output Voltage

Do not change the default voltage settings as it will negatively affect UPS performance.

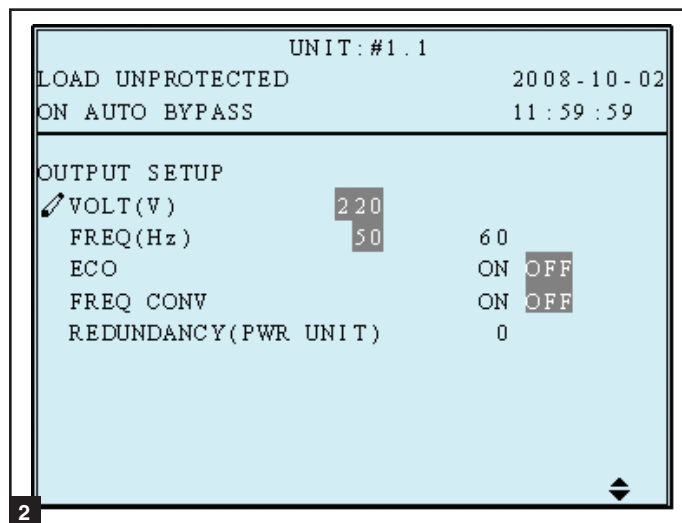

- 3 From the “FREQUENCY” screen, use the scroll buttons (▲,▼) to select the desired setting and press the enter button (↵) to confirm the setting. *Note: The output frequency setting is only used when the UPS system starts from battery or when frequency converter mode (see step 6) is enabled.*

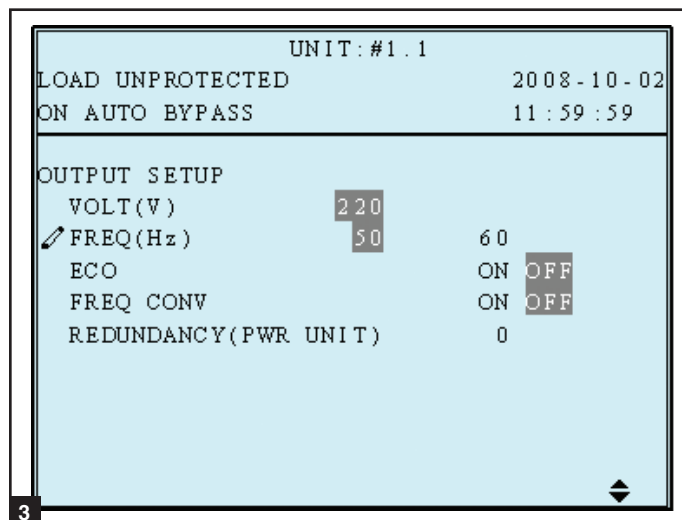

- 4 From the “ECO MODE” screen, use the scroll buttons (▲,▼) to select the desired setting and press the enter button (↵) to confirm the setting.

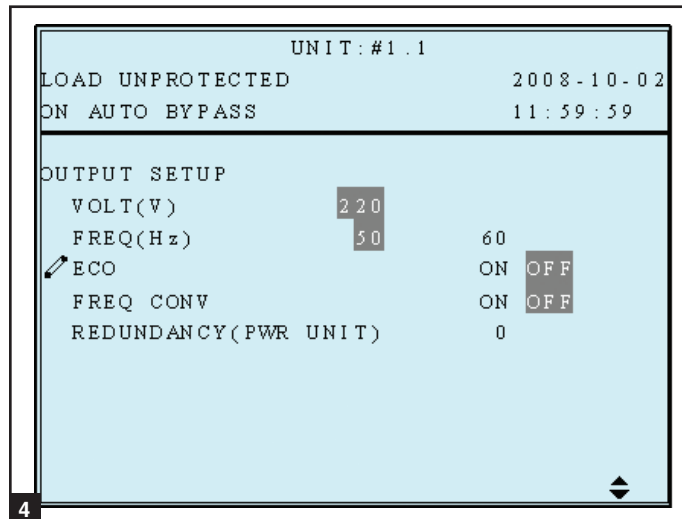

9-5-2 Output Setup (continued)

- 5 From the “FREQ CONVERTER MODE” screen, use the scroll buttons (▲,▼) to select the desired setting and press the enter button (↵) to confirm the setting. In frequency converter mode, the UPS will convert the incoming electrical power frequency to a different output frequency. Therefore, 60Hz can change to 50Hz output or 50Hz input can change to 60Hz output. When in frequency converter mode, bypass power is not an available source (the UPS will not transfer to bypass).

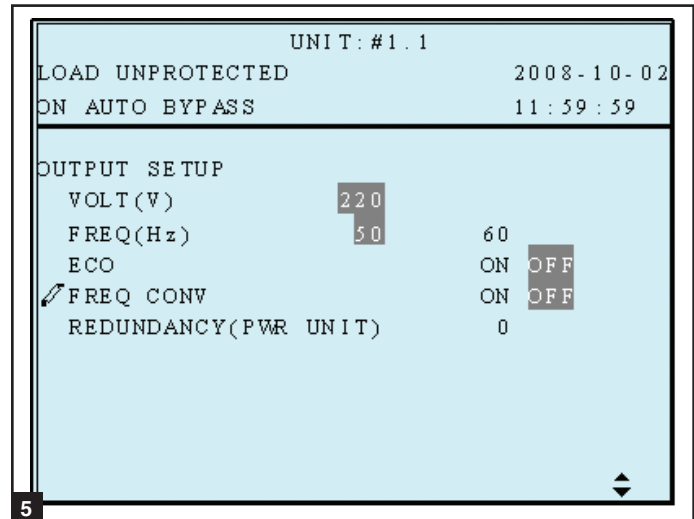

6 Redundancy

Use “▲” or “▼” to select the desired number of modules for redundancy (usually one) for redundancy, then press “↵” to confirm.

This feature allows the user to determine an acceptable power output limit to guarantee a redundancy of N+1. When this feature is enabled, the UPS will send an alarm when power usage exceeds 80% of the “non-redundant” power modules while maintaining the number of redundant power modules set. For example, on an 80kVA UPS, if a Redundancy Setup is set to “1 Power Module”, the UPS will trigger an alarm when you exceed 80% of 60kVA as to guarantee one power module for N+1 redundancy.

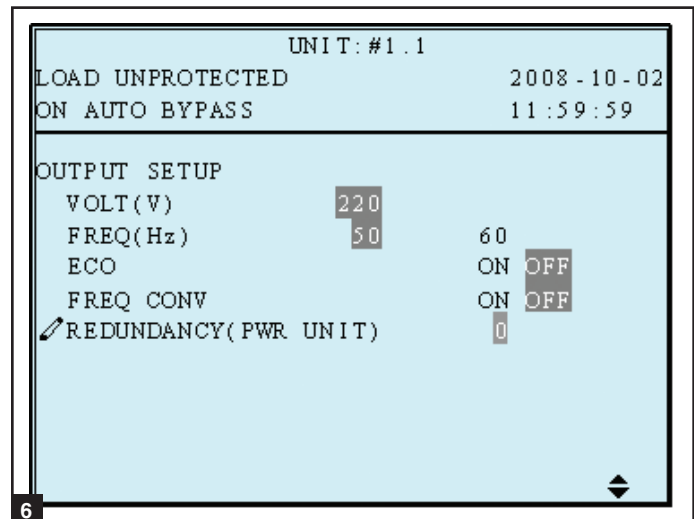

Press “ESC” to return to the “UPS SETUP” menu.

9

9-5-3 Battery Setup

Use “▲” or “▼” to select “BATTERY”, then press “↵” to confirm.



All parameters in this segment can only be changed when UPS is in “Bypass Mode”.

9-5-3 Battery Setup (continued)

- 1 Enter the UPS system setup menu. Use the scroll buttons (▲, ▼) to move the cursor to “BATTERY SETUP”, then press the enter button (↵).

At UPS startup, you must enter information about the battery, including amp hour rating, number of strings and charger current. Use the following formulas as a guide.

TYPE (AH) – The AH rating for external batteries is equal to the number after the “V” in the model name. *For example, BP480V26B = 26 AH.*

BAT STRINGS – Enter the number of battery strings connected to the UPS system. *For example, SU80K with two BP480V55, enter “2”.*

CHARGER CURRENT – See [Section 9-5-4](#) for information about setting the charger current.

- 2 From the “EXT BAT TYPE” screen, use the scroll buttons (▲, ▼) to select the desired settings and press the enter button (↵) to confirm the settings. *Note: See step 1 for additional guidance on AH settings.*

BP480V26B = 26 AH

BP480V40C = 40 AH

BP480V55 = 55 AH

BP480V78 = 78 AH

BP480V103 = 103 AH

BP480V140 = 140 AH

- 3 **Battery Strings**

Use “▲” or “▼” to select the desired number of battery strings, then press “↵” to confirm. *Note: See step 1 for information about battery string settings.*

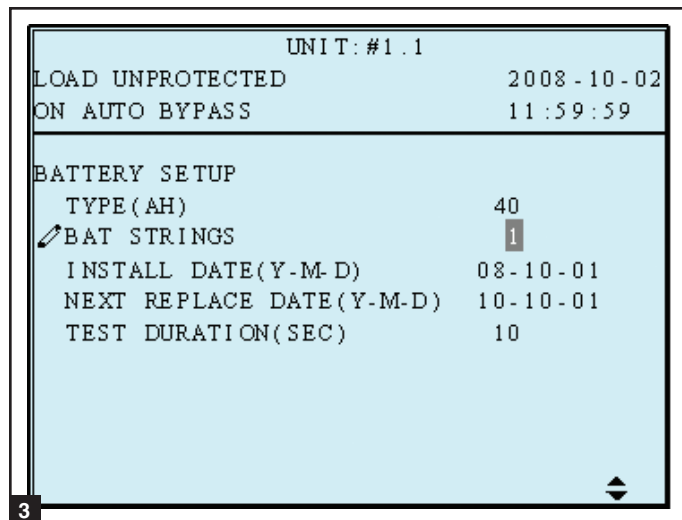
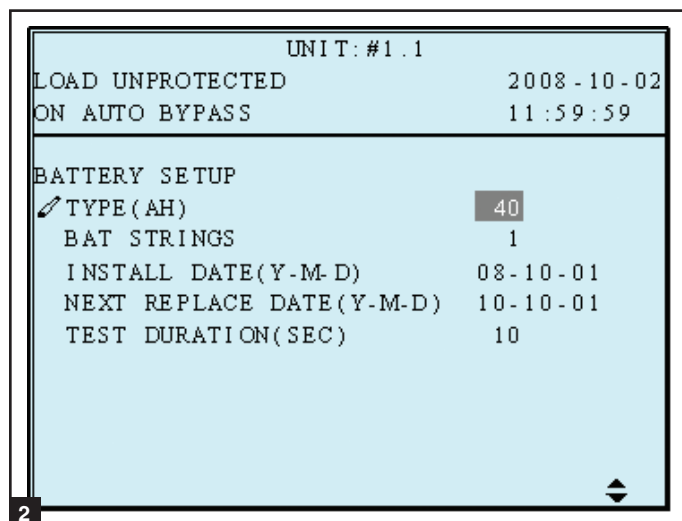
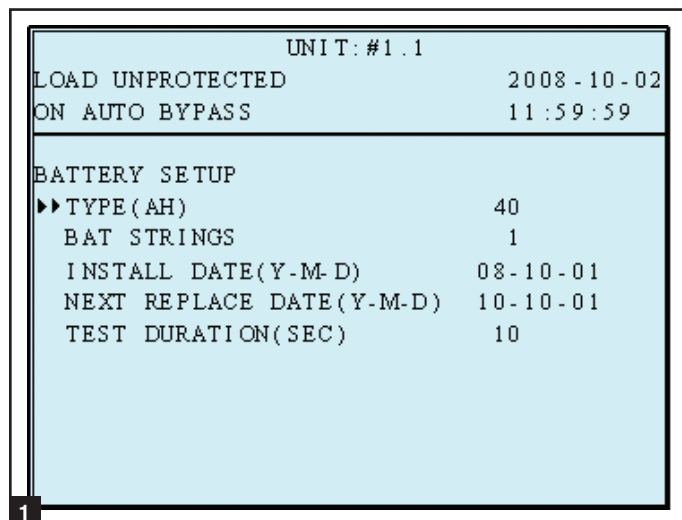

9-5-3 Battery Setup (continued)

- 4 From the “INSTALL DATE” screen, use the scroll buttons (▲,▼) to select the desired settings and press the enter button (↵) to confirm the settings.

UNIT: #1.1
LOAD UNPROTECTED 2008-10-02
ON AUTO BYPASS 11:59:59

BATTERY SETUP

TYPE(AH)	40
BAT STRINGS	1
✎INSTALL DATE(Y-M-D)	08-10-01
NEXT REPLACE DATE(Y-M-D)	10-10-01
TEST DURATION(SEC)	10

4

5 **Battery Next Replace Date**

Use “▲” or “▼” to set the next replace date, then press “↵” to confirm. (When the selected date is reached, the UPS will alarm and a message will be shown in the LCD display.)

UNIT: #1.1
LOAD UNPROTECTED 2008-10-02
ON AUTO BYPASS 11:59:59

BATTERY SETUP

TYPE(AH)	40
BAT STRINGS	1
INSTALL DATE(Y-M-D)	08-10-01
✎NEXT REPLACE DATE(Y-M-D)	10-10-01
TEST DURATION(SEC)	10

5

- 6 From the “TEST DURATION” screen, use the scroll buttons (▲,▼) to select the desired setting and press the enter button (↵) to confirm the setting.

Press “ESC” to return to the “UPS SETUP” menu.

UNIT: #1.1
LOAD UNPROTECTED 2008-10-02
ON AUTO BYPASS 11:59:59

BATTERY SETUP

TYPE(AH)	40
BAT STRINGS	1
INSTALL DATE(Y-M-D)	08-10-01
NEXT REPLACE DATE(Y-M-D)	10-10-01
✎TEST DURATION(SEC)	10

6

9-5-4 Charger Setup

Use “▲” or “▼” to select “CHARGER”, then press “←” to confirm.

- 1 From the “CHARGER CURRENT” screen, use the scroll buttons (▲,▼) to select the desired setting and press the enter button (←) to confirm the setting. *Note: The default charger current setting is 7A.*

Each internal power module has a 5 amp charger. Charger current can be set from a minimum of 2 amps total to a maximum of 5 amps per internal power module, multiplied by the number of modules. *For example, the SU80K has four internal power modules, so its charger current range is 2-20 amps.* Set the charger current value based on the size of the battery system. See [Section 9-5-3](#) for more information about determining the size of the battery system.

Warning: Setting the charger current too high may damage batteries and reduce their operational lifespan. Consult the factory for guidance before changing the default setting.

- 2 Press “▲” or “▼” to change the charging current, then press “←” to confirm.

Press “ESC” to return to the “UPS SETUP” menu.

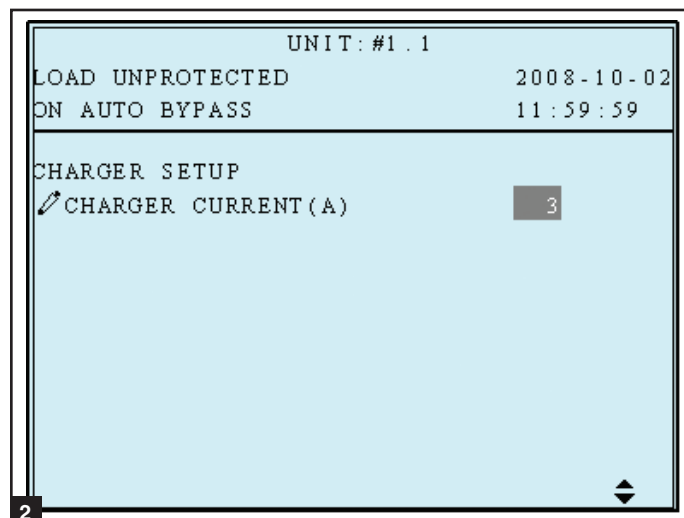
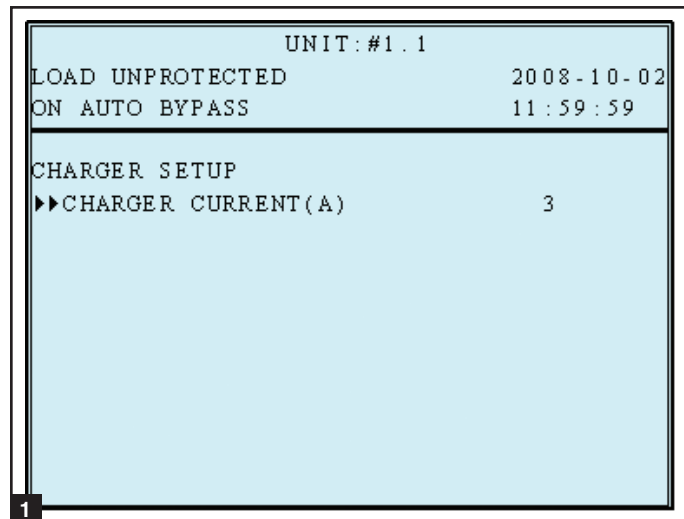

9-5-5 Parallel Setup

Use “▲” or “▼” to select “PARALLEL”, then press “←” to confirm.

- 1 Use “▲” or “▼” to select the desired item, then press “←” to confirm.

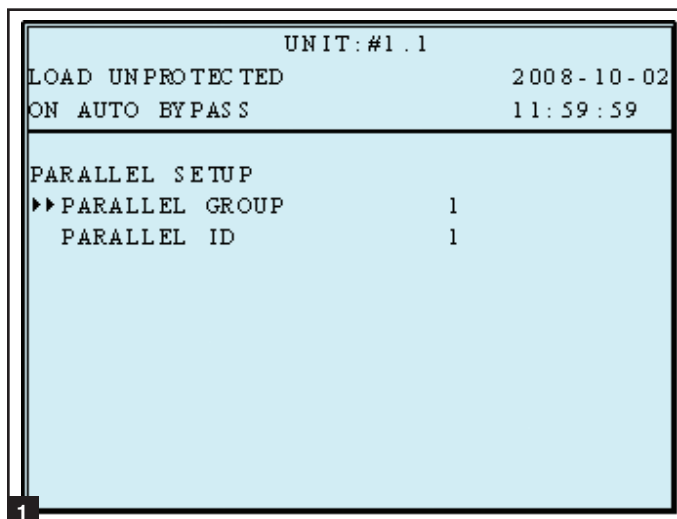

- 2 **Parallel Group**

The parallel group setting tells the UPS that it is operating in parallel. Group 1 is the default setting. See [Section 6 – Wiring](#) for wiring considerations. *Note: Possible settings are 1 or 2.*

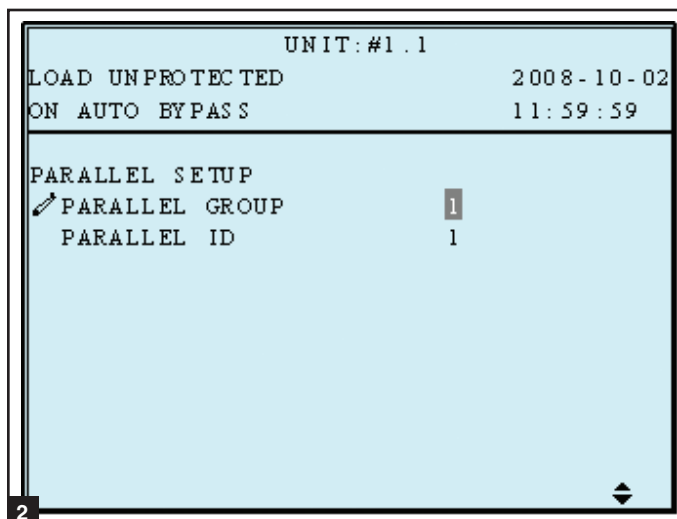

- 3 **Parallel ID**

Identifies the UPS number (1-8) within the group. When paralleling UPS systems, each must have a unique Parallel ID.

Press “ESC” to return to the “UPS SETUP” menu.

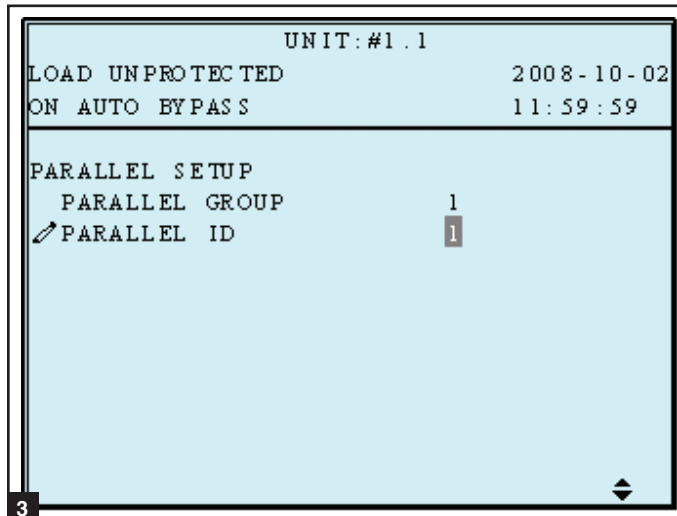

9 – Display and Configuration (continued)

9-5-6 Control & Test Setup

Use “▲” or “▼” to select “CONTROL & TEST”, then press “←” to confirm.

- 1 Use “▲” or “▼” to select the desired item, then press “←” to confirm.

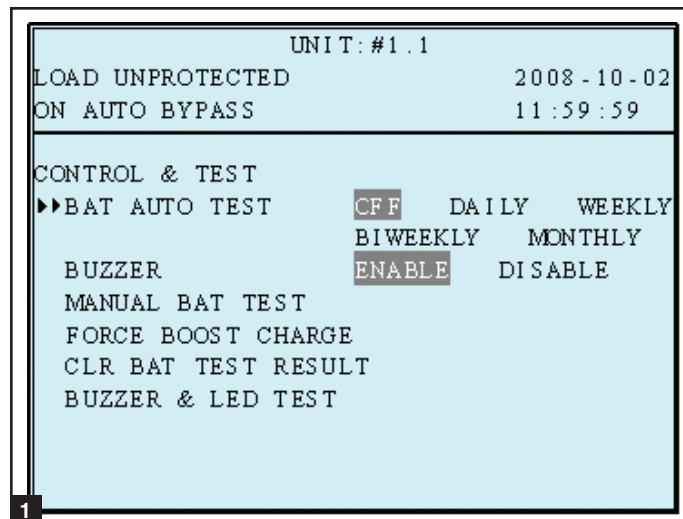

- 2 **Battery Auto Test**

Use “▲” or “▼” to select the desired item, then press “←” to confirm. Allows for scheduling of a battery test frequency for the duration selected in section 9-5-3 step 6.

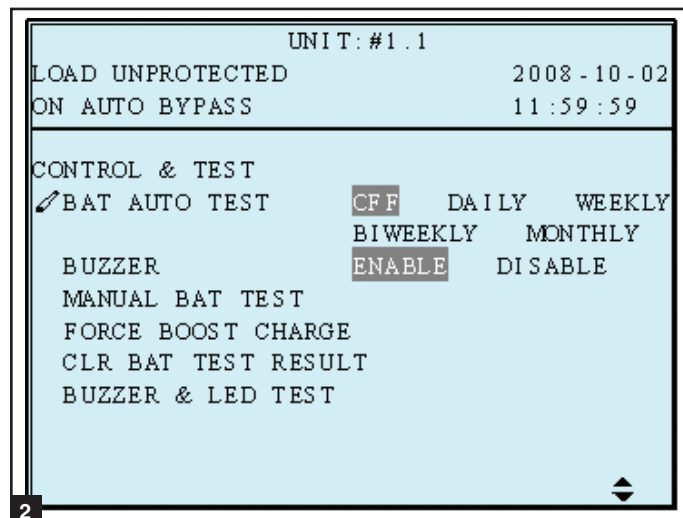

- 3 **Buzzer**

Use “▲” or “▼” to select enable or disable the buzzer, then press “←” to confirm. Silences the audible alarm.

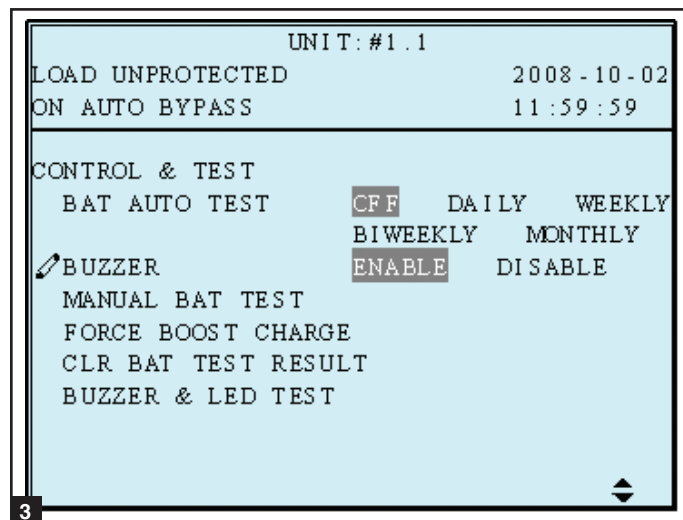

9-5-6 Control & Test Setup (continued)

4 Manual Battery Test

Press "←" to execute "MANUAL BAT TEST". Allows you to run a battery test at a non-scheduled time at the user's discretion.

(This item is only accessible for administrator! The Password will be needed.)

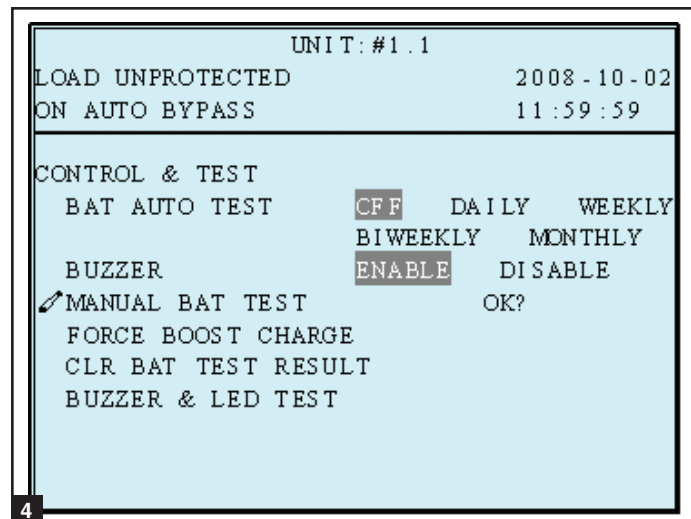

5 Force Boost Charge

Press (←) to execute "FORCE BOOST CHARGE" Enables activating the boost charge which is at a voltage of 20% higher than the nominal setting. Warning: Boosting battery charge rate for extended periods may damage the battery system.

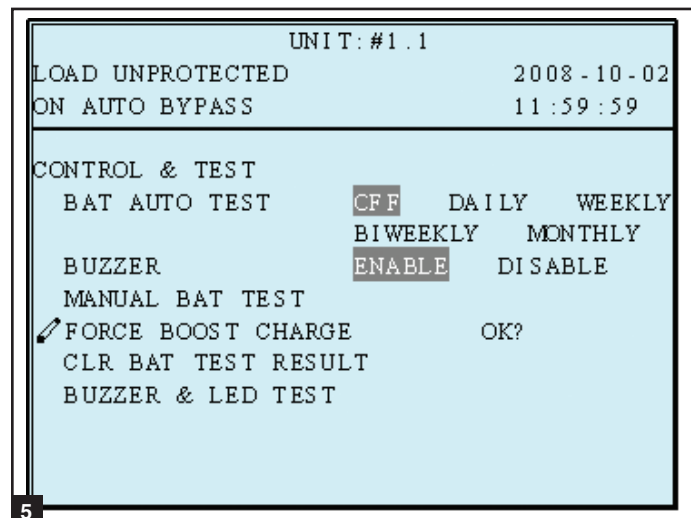

6 Clear Battery Test Result

Press "←" to execute "CLR BAT TEST RESULT". This will clear all battery test results in log.

Note: Clearing event logs may invalidate warranty claims. All warranty claims must be accompanied by supporting event log information.

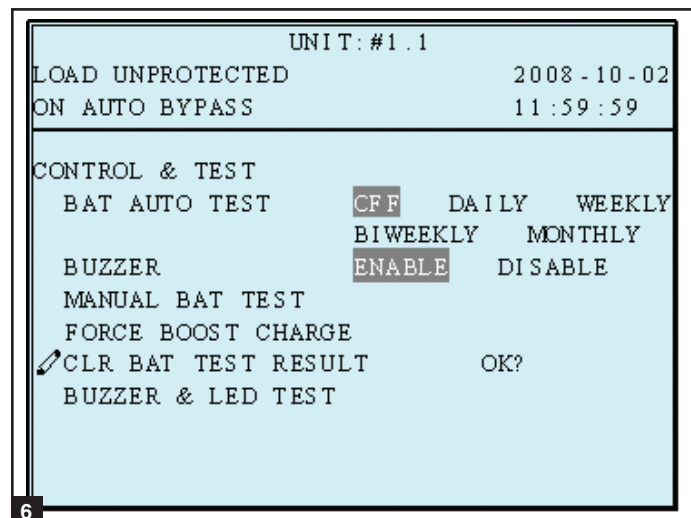

9 – Display and Configuration (continued)

9-5-6 Control & Test Setup (continued)

- 7 Select “BUZZER AND LED TEST” to initiate test of the control panel LEDs and audible alarm. You must enter the administrator password to confirm the operation.

Press “ESC” to return to the “UPS SETUP” menu.

```
UNIT: #1.1
LOAD UNPROTECTED      2008-10-02
ON AUTO BYPASS        11:59:59

CONTROL & TEST
BAT AUTO TEST        CFF  DAILY  WEEKLY
                    BIWEEKLY MONTHLY
BUZZER              ENABLE  DISABLE
MANUAL BAT TEST
FORCE BOOST CHARGE
CLR BAT TEST RESULT
BUZZER & LED TEST   OK?
```

9-5-7 Local Setup

Use “▲” or “▼” to select “LOCAL SETUP”, then press “←” to confirm.

- 1 Use “▲” or “▼” to select the desired item, then press “←” to confirm.

```
UNIT: #1.1
LOAD UNPROTECTED      2008-10-02
ON AUTO BYPASS        12:19:59

LOCAL
DATE(Y-M-D)&TIME      08-10-02  12:19:59
DATE FORMAT          Y-M-D  M-D-Y  D-M-Y
SERIAL COM ID        0
LCD CONTRAST         5
ADMIN PASSWORD       0000
USER PASSWORD        0000
LANGUAGE             ??  ??  ENGLISH
```

- 2 From the “DATE/TIME CHANGE” screen, use the scroll buttons (▲, ▼) to select the desired settings and press the enter button (↵) to confirm the settings. *Note: Changing this setting does not require an administrator login – a user login is sufficient.*

```
UNIT: #1.1
LOAD UNPROTECTED      2008-10-02
ON AUTO BYPASS        12:19:59

LOCAL
DATE(Y-M-D)&TIME      08-10-02  12:19:59
DATE FORMAT          Y-M-D  M-D-Y  D-M-Y
SERIAL COM ID        0
LCD CONTRAST         5
ADMIN PASSWORD       0000
USER PASSWORD        0000
LANGUAGE             ??  ??  ENGLISH
```

9-5-7 Local Setup (continued)

3 Date Format

Use “▲” or “▼” to change the date format, then press “←” to confirm.

(This item is user accessible!)

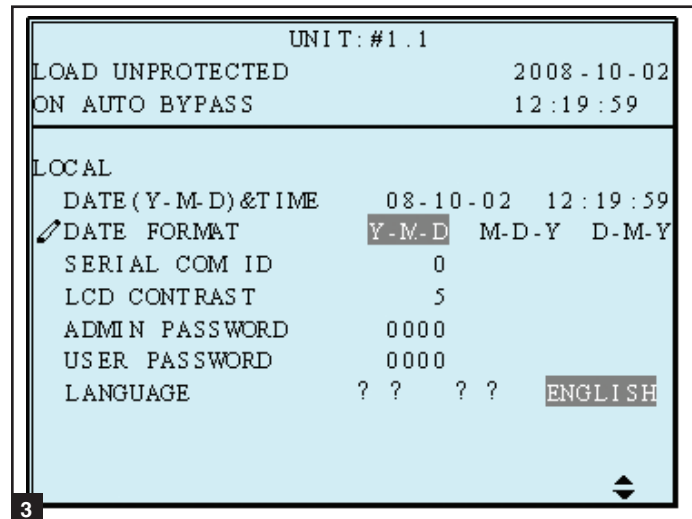

- 4 From the “SERIAL COM ID” screen, use the scroll buttons (▲, ▼) to select the desired serial port ID and press the enter button (←) to confirm the setting. *Note: This setting does not apply to standard RS-232 connections. It only applies for RS-485/RS-422 communications.*

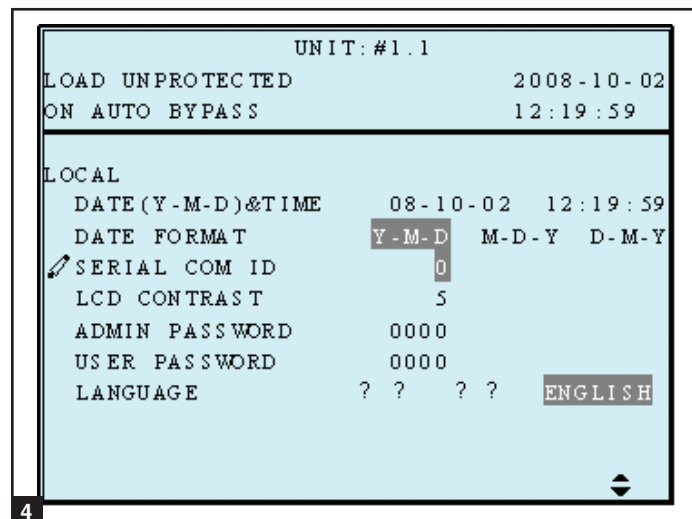

For standard RS232 connection, this ID is not used. If using the RS485/RS422 converter of other brands to connect to RS232 port, the ID can be set to 00, 01.....99.

5 LCD Contrast

Use “▲” or “▼” to set the contrast of LCD screen, then press “←” to confirm. Changes the contrast ratio of the LCD.

(This item is user accessible!)

1 is the lowest and 5 is the highest level.

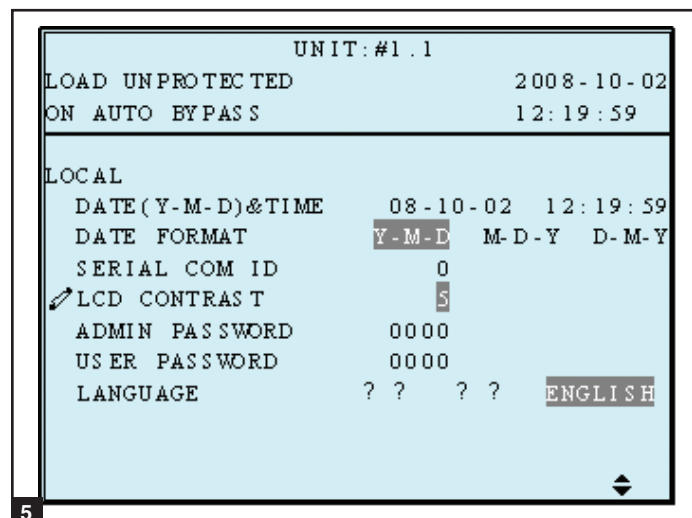

9-5-7 Local Setup (continued)

6 Administrator Password

From the “PASSWORD CHANGE” screen, use the scroll buttons (▲,▼) and the enter button (↵) to select the desired menu choice. Use the scroll buttons (▲,▼) to select the desired settings and press the enter button (↵) to confirm the settings. *Note: The administrator password should be used by qualified service personnel only.*

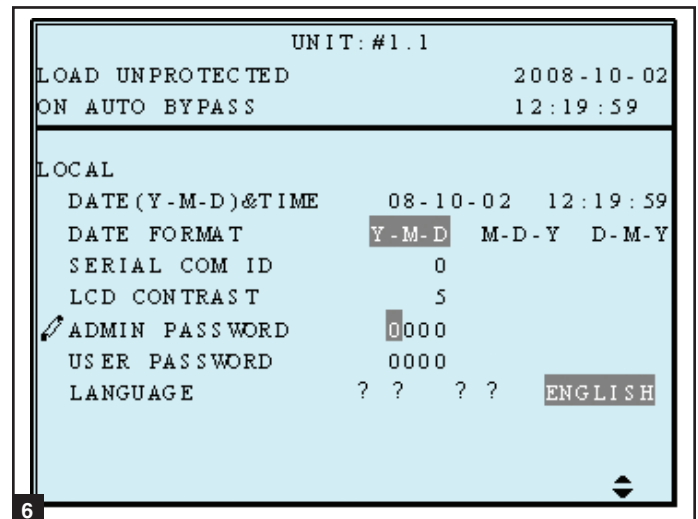

7 User Password

The password consists of 4 digits. From the “PASSWORD CHANGE” screen, use the scroll buttons (▲,▼) and the enter button (↵) to select the desired menu choice. Use the scroll buttons (▲,▼) to select the desired settings and press the enter button (↵) to confirm the settings.

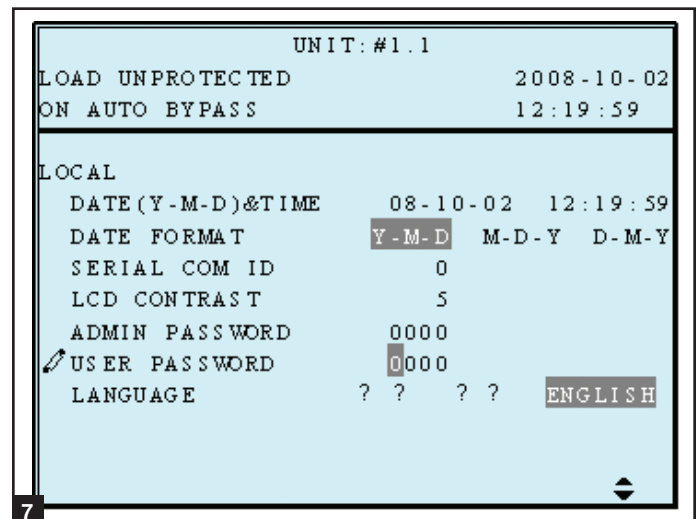

8 Language

Use “▲” or “▼” to select the language of LCD screen, then press “↵” to confirm. Select from a variety of languages to display on the LCD.

Press “ESC” to return to the “UPS SETUP” menu.

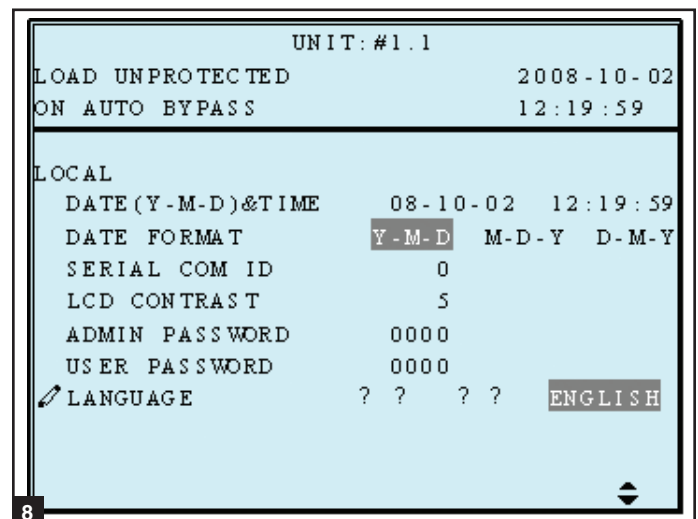

9-6 Maintenance

Use “▲” or “▼” to select “MAINTENANCE” in the main menu, then press “←” to confirm.

The first item is the series number of the UPS unit.

- 1 Use “▲” or “▼” to select the desired item, then press “←” to confirm.

```
UNIT: #1.1
LOAD UNPROTECTED      2008-10-02
ON AUTO BYPASS        11:59:59

MAINTENANCE
 S /N          E1E08200013W0
▶▶FW VERSION
 STATISTICS
 EVENT LOG
 ADVANCED
```

- 2 **Firmware Version**

Use “▲” or “▼” to select the F/W version item, then press “←” to confirm.

(The display will show the firmware version of the system and each power module.)

```
UNIT: #1.1
LOAD UNPROTECTED      2008-10-02
ON AUTO BYPASS        11:59:59

SYSTEM          TRIPPNLR 0 0
PM              PFC              INV
#1 H101010101110001  H101010201120002
#2 H101010101110001  H101010201120002
#3 H101010101110001  H101010201120002
#4 H101010101110001  H101010201120002
```

- 3 **Statistics**

Use “▲” or “▼” to read the statistics data, then press “←” to confirm.

(The display will show the “counts on battery”, “counts on bypass” and “total operation time”.)

```
UNIT: #1.1
LOAD UNPROTECTED      2008-10-02
ON AUTO BYPASS        11:59:59

ON BAT COUNTS          10
ON BYPASS COUNTS       123
OPERATION TIME (Y-D-H-M) 00-003-04-59
```

9-6 Maintenance (continued)

4 Event Log

Use “▲” or “▼” to read the event log, then press “←” to confirm.

```
UNIT:#1.1
LOAD UNPROTECTED          2008-10-02
ON AUTO BYPASS            11:59:59

<001> 08-10-02 08:10:46
    Bypass Freq Abnormal
<002> 08-10-02 08:10:58
    Mains Input Voltage Abnormal
<003> 08-10-02 08:10:58
    Mains Input Freq Abnormal
<004> 08-10-02 08:10:59
    Output Breaker Off
<005> 08-10-02 08:10:59
    On Bypass
```

5 Advance

Use “▲” or “▼” to select the “ADVANCED” item, then press “←” to confirm.

The “ADVANCED” item includes “clear statistics”, “clear event log” “firmware upgrade” and “other status monitor for service”.

(This item is only accessible for administrator! The Password will be required to confirm again.)

Warning: Clearing or erasing the event log may invalidate warranty claims. All warranty claims must be accompanied by supporting event log information.

```
UNIT:#1.1
LOAD UNPROTECTED          2008-10-02
ON AUTO BYPASS            11:59:59

ADVANCED
▶▶CLR STATISTICS
  CLR EVENT LOG
  FW UPGRADE
  OTHERS
```

Press “ESC” to return to the “UPS SETUP” menu.

10 – Communications

Note: The communications connections described in this section are optional. The UPS system will function properly without these connections.

10-1 Communications Interfaces

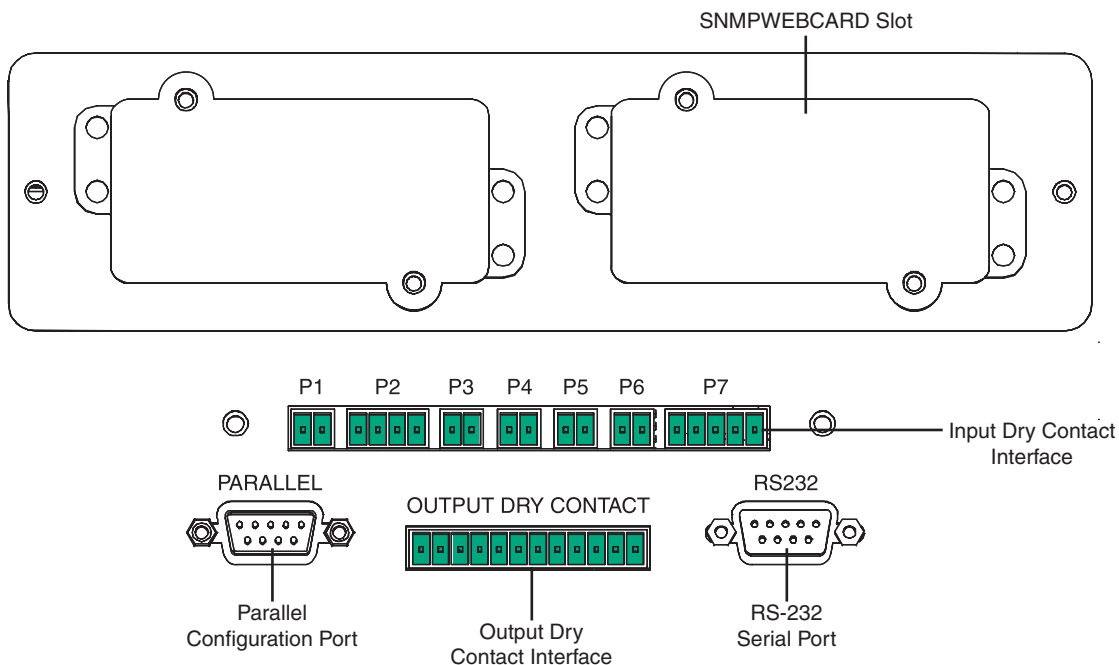

Note: The following connectors are provided with the UPS: P1, P2 and a 12 position strip for the output dry contacts. P3 and P7 are only shipped with the optional BP480V26P or BP480V40C matching battery cabinet.

10-2 SNMPWEBCARD Slot

Remove the cover panel to install a Tripp Lite SNMPWEBCARD accessory. The SNMPWEBCARD accessory provides an Ethernet interface for the UPS system and enables remote monitoring and control via SNMP, Web browser or telnet. Visit www.tripplite.com for more information about ordering the SNMPWEBCARD accessory.

10-3 Input Dry Contact Interface

The input dry contact interface receives contact-closure signals that allow the UPS system to receive commands and monitor external battery conditions:

- P1—Remote Emergency Power Off (EPO) (See section 10-4.)
- P2—Auxiliary Dry Contact Inputs (2 sets) (Input Contact A: Pin 1,2 rated for 12V DC minimum, 0.1A (nominal); Input Contact B: Pin 3,4 rated for 12V DC minimum, 0.1A (nominal). (See section 10-5.)
- P3—External Battery Cabinet Temperature 1 (Temperature Sensor Inputs from external battery cabinets. See section 10-6.)
- P4—External Battery Cabinet Temperature 2 (Temperature Sensor Inputs from external battery cabinets. See section 10-6.)
- P5—External Battery Cabinet Temperature 3 (Temperature Sensor Inputs from external battery cabinets. See section 10-6.)
- P6—External Battery Cabinet Temperature 4 (Temperature Sensor Inputs from external battery cabinets. See section 10-6.)
- P7—External Battery Status (For use with battery status cable supplied with external battery cabinets-BP480V26B or BP480V40C.)

Note: Do not apply voltages to the repo contacts or auxiliary dry contacts. Damage to the UPS may result. For the REPO, the switch must be latching in order to keep output power OFF from the UPS output.

10 – Communications (continued)

10-4 Remote Emergency Power Off (EPO) Circuit Diagram

The Remote Emergency Power Off (EPO) input connection (P1) allows you to connect the UPS system to your facility's EPO circuit. Connecting the UPS system to the EPO circuit enables remote emergency shutdown of the UPS system's output. Connect EPO input to a user-supplied remote switch, following the circuit diagram below. This contact is normally open. Supplied REPO button must be a latching type and in a NC position. When opened, the UPS goes to bypass. The inverter must then be re-started (by pressing the inverter ON button) to return to on-line mode. Contact rated for 12V DC minimum, 0.1A (nominal).

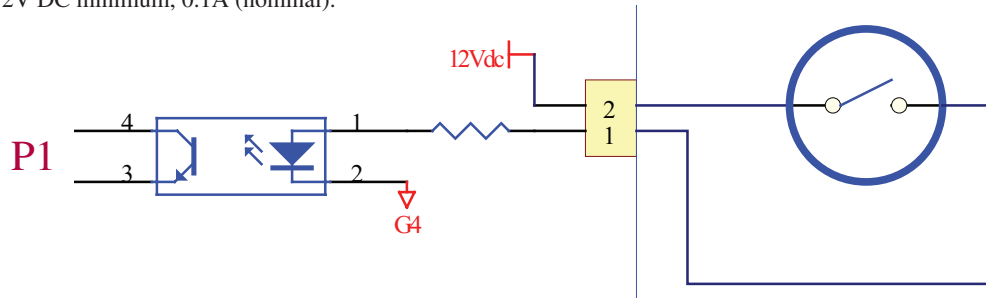

10-5 Auxiliary Dry Contact Input Circuit Diagram

The auxiliary dry contact input connections (P2) allow the UPS system to receive external signals. These contacts are normally open. External contacts rated for 12V DC minimum, 0.1A (nominal).

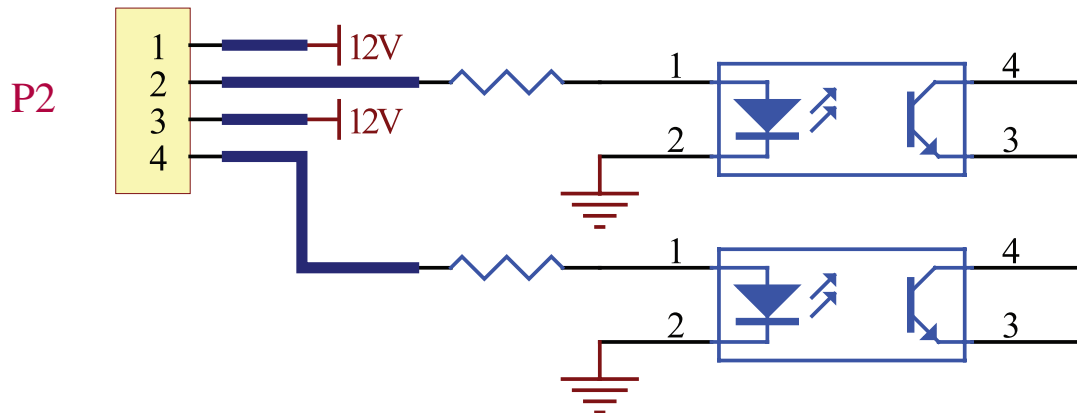

10-6 External Battery Cabinet Temperature Inputs

The external battery cabinet temperature input connections (P3, P4, P5, P6) allow the UPS system to receive signals from an optional accessory that monitors the temperature of external battery cabinets. Visit www.tripplite.com/support for more information.

10-7 External Battery Status Input

The external battery cabinet status input connection (P7) allows the UPS system to receive external battery cabinet status signals through an optional cable. Pin 1 = +12V; Pin 2 = detection cable connected; Pin 3 = battery cabinet breaker status (signal active= breaker on; signal inactive = off); Pin 4 = reserved; Pin 5 = reference voltage. Visit www.tripplite.com/support for more information.

10-8 Output Dry Contact Interface Detail

The UPS system has six dry contact output connections. These contacts can be normally open or normally closed.

Default Messages

Contact	Message	Description
Pin 1-2	Load on inverter	The UPS system is working normally.
Pin 3-4	Load on auto bypass	The UPS system is in bypass mode.
Pin 5-6	Mains input failure with load on inverter	Utility power is absent (blackout) or abnormal. The UPS system is in battery backup mode.
Pin 7-8	Battery low	The UPS system is in battery backup mode, and battery voltage is lower than 220V.
Pin 9-10	Bypass input abnormal	The bypass input is abnormal (frequency / phase).
Pin 11-12	Battery test failure	The battery voltage is lower than the reference value.

Optional Messages

Message	Description
Internal communication failure	Communication with one of the internal components is not normal.
External parallel communication failure	In a parallel redundancy installation, the parallel communication is not normal.
Output overload warning/shutdown	The load exceeds the capacity of the UPS system.
Power module fault shutdown	The UPS system has shut down due to an internal power module failure.
Power module warning	An internal power module has an error, but the UPS system can still function normally.
EPO activated	The UPS system's output is disabled by the emergency power off (EPO) function.
Load on manual bypass	The UPS system is in manual bypass mode.
Battery cabinet over temperature warning/shutdown	The temperature of the external battery cabinet is too high.
Output voltage abnormal	The UPS system's output voltage is too high or too low.
Battery need replace	According to the data in the "BAT DATE SETTING", the UPS system is overdue for battery replacement. (See Section 9-5-3 for more information.)
Bypass over temperature warning/shutdown	The temperature of the bypass "static transfer switch" is too high.
Battery ground fault	The battery has a grounding error.
Bypass static switch fault	The bypass "static transfer switch" is abnormal.

Note: If you require optional messages to be enabled, contact Tripp Lite.

10-9 Output Dry Contact Circuit Diagram

The UPS system has six dry contact output connections. These contacts can be normally open or normally closed. Contacts are rated for 250V AC/28V DC; 8A.

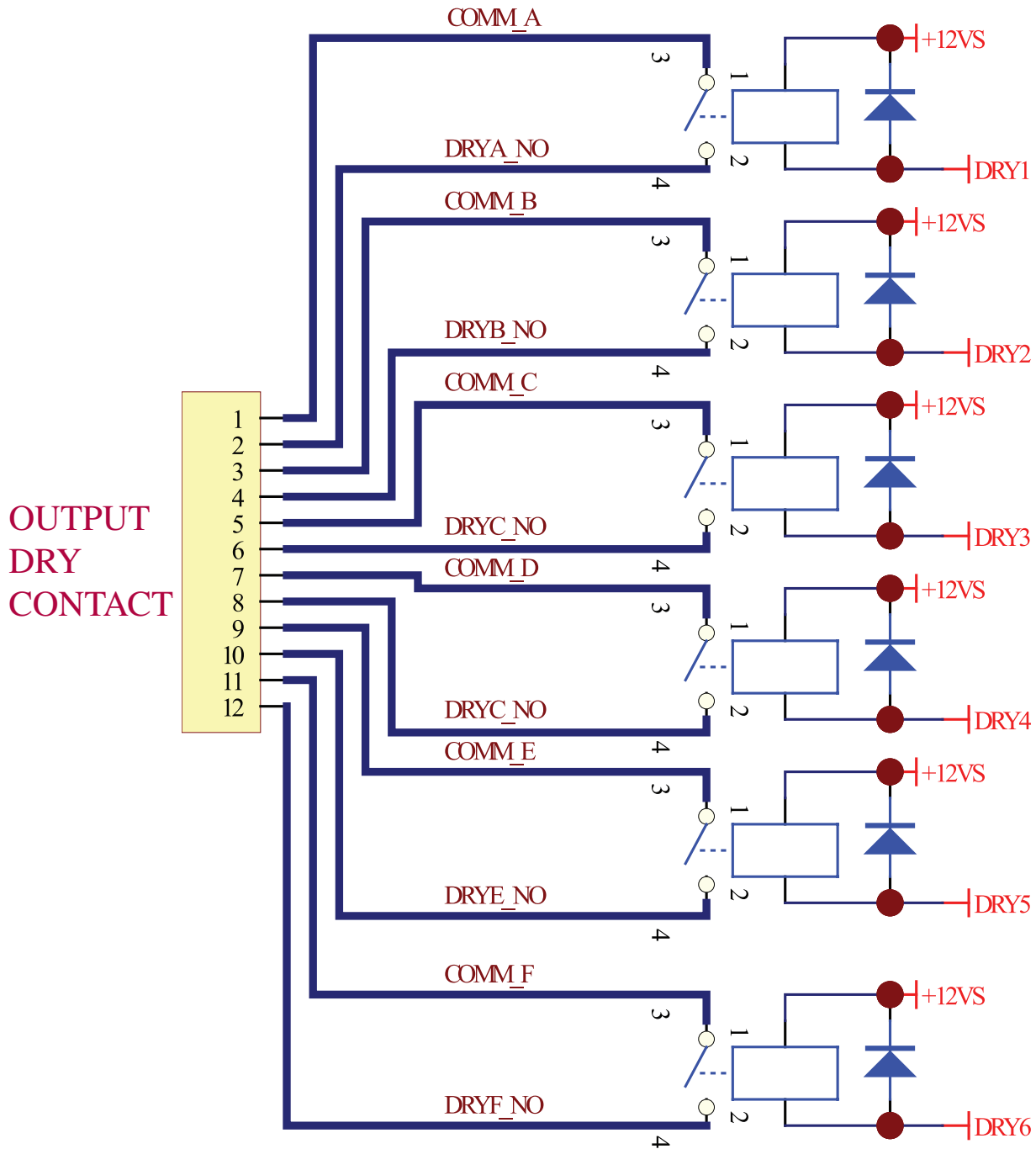

10 – Communications (continued)

10-10 RS-232 Serial Port Circuit Diagram

The RS-232 DB9 serial port connects the UPS system to a workstation or server (cable included). By communicating with the UPS system through this port, Tripp Lite's PowerAlert UPS management software (included) can monitor and control the UPS system. PowerAlert also serves as an SNMP proxy allowing the UPS system to appear as an SNMP-manageable device on the network.

RS-232 signals and operations include: load level, battery status, battery level, operation mode, AC input voltage, AC output voltage, AC input frequency, internal temperature, set shut-down delay time, enable/disable alarm and remote shutdown.

Hardware

Baud Rate: 2400 BPS

Data Length: 8 bits

Stop Bit: 1 bit

Parity: NONE

Pin Assignment

Pin 2: TXD (Transmit Data)

Pin 3: RXD (Receive Data)

Pin 5: GND (Signal Ground)

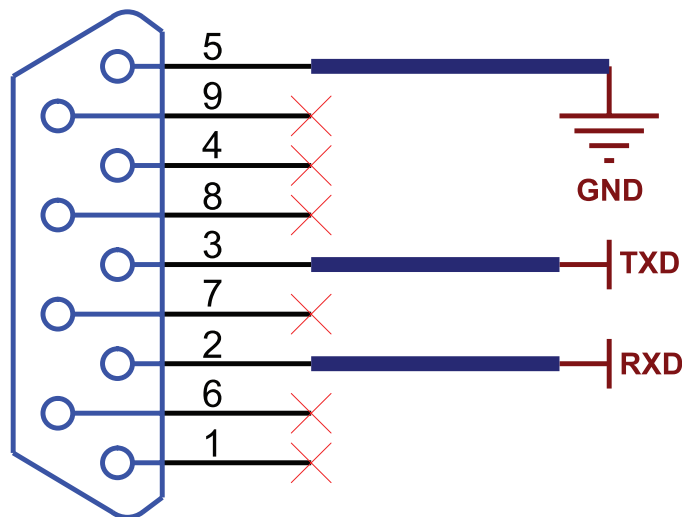

10-11 Parallel Configuration Port

The parallel configuration port allows the UPS system to be connected to another UPS system of identical type and capacity for use in a parallel configuration (1+1) configuration for increased capacity or increased fault-tolerance. **Warning: Use only the parallel configuration cable that is included with the UPS system. Attempting to use an incompatible cable may damage the UPS systems and create a serious risk of personal injury and property damage.**

11 – Specifications

11-1 UPS System Technical Specifications

Model (Capacity)		SU80K (80kVA/64kW)		
Input	Input Voltage	120/208V AC, 3Ø, 4-wire + ground		
	Voltage Regulation	-25% / +20%		
	Harmonic Distortion	< 4% (Full Load)		
	PFC (Full Load)	> 0.99		
	Frequency	50 / 60 Hz		
	Frequency Tolerance	45 ~ 65 Hz		
Output	Output Voltage	120/208V AC, 3Ø, 4-wire + ground		
	Output Frequency	50 / 60 Hz		
	Total Harmonic (Linear Load)	≤3%		
	Voltage Regulation	Static	±1%	
		Dynamic	±7% (10% ~ 90% Linear Load)	
	Frequency Regulation	Interior Oscillator	±0.05 Hz	
		Synchronized	±5%	
Overload	≤125% : 10 minutes; ≤150% : 1 minute			
Audible Warning	Battery Backup	Intermittent		
	UPS Abnormal	Continuous		
Display	LED	UPS Status: Normal • Bypass • Backup • Fault		
	LCD	Input/Output • Bypass • Inverter • Frequency • Loading • Battery Voltage UPS abnormal messages with intelligent self-diagnosis.		
Interface	Standard	RS-232, Dry Contact		
	Optional	SNMPWEBCARD		
Others	Parallel Redundancy	Yes (1+1 for 2 UPS systems of the same type and capacity only.)		
	EPO	Standard (Local and Remote)		
	SRAM Event Log	500 Records		
	Parameter Configuration	Yes		
	Hot Standby Installation	Optional		
	Battery Temperature Compensation	Optional		
	Battery Cold-Start	Standard		
Overall	Efficiency	Normal	92%	
		ECO	96%	
	Transfer Time	0 ms		
	Temperature	32° F ~ 104° F (0° C ~ 40° C)		
	Humidity (non-condensing)	90%		
	Noise (1 m)	70 dBA		
	Dimensions (Power Module)	Width	20.47 in (520 mm)	
		Depth	40.39 in (1026 mm)	
		Height	66.77 in (1696 mm)	
	Weight (Power Module)	1,444 lb (655 kg)		

11-2 UPS System Floor Loading Table

Model	SU80K
Weight	1,444 lb (655 kg)
Floor Loading	1228 kg/m ²

11-3 Battery Pack Floor Loading Table

Model	BP480V26B (40 12V batteries; 26AH each)	BP480V40C (40 12V batteries; 40AH each)
Weight	1,036 lb (470 kg)	1,543 lb (700 kg)
Floor Loading	1064 kg/m ²	1575 kg/m ²

12 – Storage and Service

Storage

The UPS system must be stored in a clean, secure environment with a temperature less than 40° C (104° F) and a relative humidity less than 90% (non-condensing). Store the UPS system in its original shipping container if possible. If installation occurs more than 6 months after you receive the UPS system, recharge the batteries for at least 24 hours prior to use. Do not rely on the UPS system to provide backup power to connected equipment until the batteries are fully charged. *Note: If the UPS system remains off for an extended period of time, it should be turned on periodically to allow the batteries to recharge. The UPS system should be turned on and the batteries should be recharged at least one uninterrupted 24-hour period every 3 months. Failure to recharge the batteries periodically may cause irreversible battery damage.*

Service

Your Tripp Lite product is covered by the warranty described in this manual. A variety of Extended Warranty and On-Site Service Programs are also available from Tripp Lite. For more information on service, visit www.tripplite.com/support. Before returning your product for service, follow these steps:

1. Review the installation and operation procedures in this manual to insure that the service problem does not originate from a misreading of the instructions.
2. If the problem continues, do not contact or return the product to the dealer. Instead, visit www.tripplite.com/support.
3. If the problem requires service, visit www.tripplite.com/support and click the Product Returns link. From here you can request a Returned Material Authorization (RMA) number, which is required for service. This simple on-line form will ask for your unit's model and serial numbers, along with other general purchaser information. The RMA number, along with shipping instructions will be emailed to you. Any damages (direct, indirect, special or consequential) to the product incurred during shipment to Tripp Lite or an authorized Tripp Lite service center is not covered under warranty. Products shipped to Tripp Lite or an authorized Tripp Lite service center must have transportation charges prepaid. Mark the RMA number on the outside of the package. If the product is within its warranty period, enclose a copy of your sales receipt. Return the product for service using an insured carrier to the address given to you when you request the RMA.

13 – Warranty and Warranty Registration

Limited Warranty

Seller warrants this product, if used in accordance with all applicable instructions, to be free from original defects in material and workmanship for a period of 2 years (except U.S., Canada and Mexico: 1 year) from the date of initial purchase. If the product should prove defective in material or workmanship within that period, Seller will repair or replace the product, in its sole discretion. Service under this Warranty includes parts and Tripp Lite service center labor. On-site service plans are available from Tripp Lite through authorized service partners (in most areas). Visit www.tripplite.com for details. International customers should contact Tripp Lite support at intlservice@tripplite.com.

THIS WARRANTY DOES NOT APPLY TO NORMAL WEAR OR TO DAMAGE RESULTING FROM ACCIDENT, MISUSE, ABUSE OR NEGLIGENCE. SELLER MAKES NO EXPRESS WARRANTIES OTHER THAN THE WARRANTY EXPRESSLY SET FORTH HEREIN. EXCEPT TO THE EXTENT PROHIBITED BY APPLICABLE LAW, ALL IMPLIED WARRANTIES, INCLUDING ALL WARRANTIES OF MERCHANTABILITY OR FITNESS, ARE LIMITED IN DURATION TO THE WARRANTY PERIOD SET FORTH ABOVE; AND THIS WARRANTY EXPRESSLY EXCLUDES ALL INCIDENTAL AND CONSEQUENTIAL DAMAGES. (Some states do not allow limitations on how long an implied warranty lasts, and some states do not allow the exclusion or limitation of incidental or consequential damages, so the above limitations or exclusions may not apply to you. This Warranty gives you specific legal rights, and you may have other rights which vary from jurisdiction to jurisdiction).

Tripp Lite; 1111 W. 35th Street; Chicago IL 60609; USA

WARNING: The individual user should take care to determine prior to use whether this device is suitable, adequate or safe for the use intended. Since individual applications are subject to great variation, the manufacturer makes no representation or warranty as to the suitability or fitness of these devices for any specific application.

Warranty Registration

Visit www.tripplite.com/warranty today to register the warranty for your new Tripp Lite product. You'll be automatically entered into a drawing for a chance to win a FREE Tripp Lite product!*

* No purchase necessary. Void where prohibited. Some restrictions apply. See website for details.

Regulatory Compliance Identification Numbers

For the purpose of regulatory compliance certifications and identification, your Tripp Lite product has been assigned a unique series number. The series number can be found on the product nameplate label, along with all required approval markings and information. When requesting compliance information for this product, always refer to the series number. The series number should not be confused with the marking name or model number of the product.

FCC Notice, Class A

This device complies with part 15 of the FCC Rules. Operation is subject to the following two conditions: (1) This device may not cause harmful interference, and (2) this device must accept any interference received, including interference that may cause undesired operation.

Note: This equipment has been tested and found to comply with the limits for a Class A digital device, pursuant to part 15 of the FCC Rules. These limits are designed to provide reasonable protection against harmful interference when the equipment is operated in a commercial environment. This equipment generates, uses, and can radiate radio frequency energy and, if not installed and used in accordance with the instruction manual, may cause harmful interference to radio communications. Operation of this equipment in a residential area is likely to cause harmful interference in which case the user will be required to correct the interference at his own expense. The user must use shielded cables and connectors with this equipment. Any changes or modifications to this equipment not expressly approved by Tripp Lite could void the user's authority to operate this equipment.

Tripp Lite has a policy of continuous improvement. Specifications are subject to change without notice.

Note on Labeling

These symbols are used on the label:

V~	AC Voltage
V==	DC Voltage
Ø	Phase
⊕	Ground



1111 W. 35th Street, Chicago, IL 60609 USA
www.tripplite.com/support