

**Powerware® 9390
Integrated Distribution Cabinet (IDC)
Installation and Operation Manual**

For use with Powerware 9390 40–80 kVA UPS Models



Powerware

**Powerware® 9390
Integrated Distribution Cabinet (IDC)
Installation and Operation Manual**

For use with Powerware 9390 40–80 kVA UPS Models

IMPORTANT SAFETY INSTRUCTIONS SAVE THESE INSTRUCTIONS

This manual contains important instructions that you should follow during installation and maintenance of the UPS and batteries. Please read all instructions before operating the equipment and save this manual for future reference.

CONSIGNES DE SÉCURITÉ IMPORTANTES CONSERVER CES INSTRUCTIONS

Ce manuel comporte des instructions importantes que vous êtes invité à suivre lors de toute procédure d'installation et de maintenance des batteries et de l'onduleur. Veuillez consulter entièrement ces instructions avant de faire fonctionner l'équipement et conserver ce manuel afin de pouvoir vous y reporter ultérieurement.

Special Symbols

The following are examples of symbols used on the UPS or accessories to alert you to important information:



RISK OF ELECTRIC SHOCK - Indicates that a risk of electric shock is present and the associated warning should be observed.



CAUTION: REFER TO OPERATOR'S MANUAL - Refer to your operator's manual for additional information, such as important operating and maintenance instructions.



This symbol indicates that you should not discard the UPS or the UPS batteries in the trash. This product contains sealed, lead-acid batteries and must be disposed of properly. For more information, contact your local recycling/reuse or hazardous waste center.



This symbol indicates that you should not discard waste electrical or electronic equipment (WEEE) in the trash. For proper disposal, contact your local recycling/reuse or hazardous waste center.



ON – Indicates that the switch is in the ON position.



OFF – Indicates that the switch is in the OFF position.



PHASE – The word "phase."

This page intentionally left blank.

Table of Contents

1	Introduction	1-1
1.1	IDC Features	1-2
1.1.1	Maintenance Bypass and Maintenance Isolation Breakers	1-2
1.1.2	Output Transformer	1-2
1.1.3	Installation Features	1-2
1.1.4	Expansion	1-2
1.2	IDC Options	1-2
1.2.1	Bypass Input Breaker	1-2
1.2.2	Rectifier Input Breaker	1-2
1.2.3	Distribution Panel	1-2
1.2.4	Distribution Breakers	1-3
1.2.5	Lug Output	1-3
1.2.6	Remote Emergency Power-off	1-3
1.2.7	Output Isolation Transformer	1-3
1.3	IDC Configurations	1-3
1.4	Safety Warnings	1-4
1.5	Conventions Used in This Manual	1-5
1.6	For More Information	1-5
1.7	Getting Help	1-6

Section I – Installation

2	IDC Installation Plan and Unpacking	2-1
2.1	Creating an Installation Plan	2-1
2.2	Preparing the Site	2-1
2.2.1	Environmental Considerations	2-2
2.2.2	Preparing for Wiring the IDC	2-2
2.3	Inspecting and Unpacking the IDC	2-3
3	Installing the IDC	3-1
3.1	Preliminary Installation Information	3-1
3.2	Unloading the Cabinet from the Pallet	3-2
3.3	IDC Installation	3-5
3.3.1	Line-up-and-Match IDC Installation	3-6
3.3.1.1	Installing IDC Line-up-and-Match Power Wiring	3-10
3.3.1.2	Installing Terminal P1 Interface Connections	3-11
3.3.2	Standalone IDC Installation	3-12
3.3.2.1	Installing IDC Standalone Power Wiring	3-13
3.3.2.2	Installing Terminal P1 Interface Connections	3-14
3.4	Initial Startup	3-15
3.5	Completing the Installation Checklist	3-15

Section II – Operation

4	Understanding IDC Operation	4-1
4.1	UPS Mode	4-1
4.2	Maintenance Bypass Mode	4-1
5	IDC Controls and Operation	5-1
5.1	IDC Controls	5-1
5.2	IDC Operation	5-8
5.2.1	Using the UPS when an IDC is Installed	5-8
5.2.2	Transferring the UPS to Maintenance Bypass	5-8
5.2.3	Transferring the UPS from Maintenance Bypass	5-9
5.2.4	Using the Remote Emergency Power-off (REPO) Switch	5-10
6	Maintaining the IDC	6-1
6.1	Important Safety Instructions	6-1
6.2	Performing Preventive Maintenance	6-1
6.2.1	Daily Maintenance	6-1
6.2.2	Periodic Maintenance	6-2
6.2.3	Annual Maintenance	6-2
6.3	Short Circuits	6-2
6.4	Maintenance Training	6-2
7	Product Specifications	7-1
7.1	Model Numbers	7-1
7.2	IDC Input	7-1
7.3	IDC Output	7-1
7.4	Environmental Specifications	7-1
8	Warranty	8-1
	Appendix A – Installation Reference	A-1

List of Figures

Figure 1-1. The Powerware 9390 40–80 kVA IDC	1-1
Figure 2-1. Powerware 9390 40–80 kVA IDC as Shipped on Pallet	2-3
Figure 3-1. Removing the Front Shipping Bracket	3-3
Figure 3-2. Removing the Rear Shipping Bracket	3-4
Figure 3-3. UPS with Line-up-and-Match IDC	3-6
Figure 3-4. IDC Knockout Plug and Hanger Bracket Locations	3-8
Figure 3-5. UPS to IDC Joining Brackets	3-9
Figure 3-6. Powerware 9390 UPS with Standalone IDC	3-12
Figure 4-1. Path of Current Through the IDC in UPS Mode	4-2
Figure 4-2. Path of Current Through the IDC in Maintenance Bypass Mode	4-3
Figure 5-1. Powerware 9390 40–80 kVA IDC Controls – with Distribution Panel Option (208V)	5-2
Figure 5-2. Powerware 9390 40–80 kVA IDC Controls – with Distribution Breaker Option (208V)	5-3
Figure 5-3. Powerware 9390 40–80 kVA IDC Controls – with No Distribution (208V)	5-4
Figure 5-4. Powerware 9390 40–80 kVA IDC Controls – with Distribution Panel Option (480V)	5-5
Figure 5-5. Powerware 9390 40–80 kVA IDC Controls – with Distribution Breaker Option (480V)	5-6
Figure 5-6. Powerware 9390 40–80 kVA IDC Controls – with No Distribution (480V)	5-7
Figure 5-7. Powerware 9390 IDC Controls - Interlock Operation (208V)	5-11
Figure 5-8. Powerware 9390 IDC Controls - Interlock Operation (480V)	5-12

Chapter 1

Introduction

The Eaton® Powerware® 9390 40–80 kVA Integrated Distribution Cabinet (IDC) is designed for use with the Powerware 9390 family of three-phase uninterruptible power systems (UPSs). The IDC provides the following custom configurable features, enabling adaptation and expansion without costly electrical re-work:

- Power distribution options distribute power to servers or racks via distribution panelboards, or distribute power to larger loads via distribution circuit breakers.
- Maintenance Bypass (MBP) and Maintenance Isolation (MIS) breakers enable power to completely bypass the UPS. The UPS can then be serviced or replaced in complete safety, without interrupting power to critical systems.
- An optional Bypass Input Breaker (BIB) and Rectifier Input Breaker (RIB) provide a single wiring point input to the UPS and a convenient method for removing power from the UPS, when using the maintenance bypass to supply the load.
- Voltage transformation allows changes to output voltage levels. For example, 480 Vac output from the UPS can be converted to 208/120 Vac output to serve single-phase loads. An isolation transformer can also be added to 208V UPS systems, if required.

The IDC is housed in a single, free-standing cabinet, with safety shields behind the doors for hazardous voltage protection. The cabinet matches the UPS cabinet in style and color, and can be installed in line-up-and-match or standalone configurations. Figure 1-1 shows the Powerware 9390 40–80 kVA IDC.

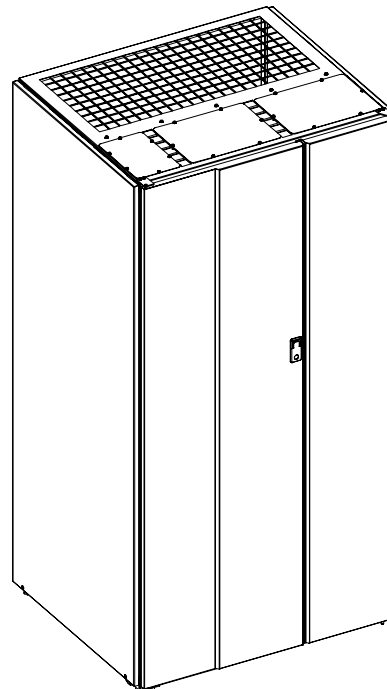

Figure 1-1. The Powerware 9390 40–80 kVA IDC

1.1 IDC Features

The IDC has many standard features that provide cost-effective and consistently reliable power protection. The descriptions in this section provide a brief overview of the IDC standard features.

1.1.1 Maintenance Bypass and Maintenance Isolation Breakers

A Maintenance Bypass breaker, in combination with the Maintenance Isolation breaker, can be used to completely isolate the UPS during service. The UPS can be serviced or replaced without interrupting power to critical systems.

1.1.2 Output Transformer

A 480/208 Vac output transformer provides a 208 Vac output from the 480 Vac UPS output for applications that require 208 Vac, and for use with the distribution panels supplying 208/120 Vac to the critical load.

1.1.3 Installation Features

The IDC can be installed in *line-up-and-match* or *standalone* configurations. The cabinet can be permanently bolted to the floor or left standing on leveling feet. Power and control wiring can be routed through the top or bottom of the cabinet with connections made to easily accessible terminals. Line-up-and-match cabinets are wired through the side panels of the units.

1.1.4 Expansion

The IDC supports custom configurations and scalability to adapt to changing and future power and distribution needs. See paragraph 1.2 for available options.

1.2 IDC Options

Contact your Eaton sales representative for information about the following options:

1.2.1 Bypass Input Breaker

An optional BIB, for single-feed and dual-feed systems, is available to provide a single point of input power control to the UPS, and to easily remove power from the UPS for servicing.

1.2.2 Rectifier Input Breaker

An optional RIB, for dual-feed systems, is available to provide a single point of rectifier input power control to the UPS, and to easily remove power from the UPS for servicing.

1.2.3 Distribution Panel

An optional output distribution panel is available to distribute the output power from the UPS to the critical load. The IDC contains up to two 42-circuit breaker switches (Cutler-Hammer® Bolt-on Type BAB or QBHW), that can be assigned with flexibility to meet facility needs. The distribution panel is enclosed behind the hinged doors on the front of the IDC.

1.2.4 Distribution Breakers

Up to six optional output distribution breakers are available to distribute the output power from the UPS to larger critical loads. The distribution breakers are enclosed behind the hinged doors on the front of the IDC.

1.2.5 Lug Output

Optional output lugs are available to distribute the output power from the UPS directly to the facility distribution panels or to a large critical load.

1.2.6 Remote Emergency Power-off

A remote emergency power-off (REPO) pushbutton is a required option to provide shunt tripping of CB1 in situations where you must instantaneously control the output to the critical load. An external 120 Vac source is required to operate the shunt trip.

1.2.7 Output Isolation Transformer

An optional 208/208 or 480/208 Vac output isolation transformer provides an isolated output to the critical load or for a UPS that has a 480 Vac output.

1.3 IDC Configurations

The following IDC configurations are possible:

- 208V, no transformer, with MBP and MIS and:
 - no distribution – output terminal block provided
 - one or two 225A distribution panels
 - one to six 100–250A adjustable distribution breakers
 - one 225A distribution panel and one to three 100–250A adjustable distribution breakers
- 480/208V transformer, with MBP, MIS, and BIB and:
 - no distribution – output terminal block provided
 - one or two 225A distribution panels
 - one to six 100–250A adjustable distribution breakers
 - one 225A distribution panel and one to three 100–250A adjustable distribution breakers
- 208/208V transformer, with MBP, MIS, BIB, and RIB and:
 - no distribution – output terminal block provided
 - one or two 225A distribution panels
 - one to six 100–250A adjustable distribution breakers
 - one 225A distribution panel and one to three 100–250A adjustable distribution breakers

1.4 Safety Warnings

IMPORTANT SAFETY INSTRUCTIONS SAVE THESE INSTRUCTIONS

This manual contains important instructions that should be followed during installation and maintenance of the IDC. Please read all instructions before operating the equipment and save this manual for future reference.

The IDC is designed for industrial or computer room applications, and contains safety shields behind the front doors. However, the UPS system is a sophisticated power system and should be handled with appropriate care.

DANGER



This UPS system contains **LETHAL VOLTAGES**. All repairs and service should be performed by **AUTHORIZED SERVICE PERSONNEL ONLY**. There are **NO USER SERVICEABLE PARTS** inside the UPS.

WARNING



- Installation and maintenance should be performed only by qualified personnel.
- The UPS system contains its own energy source (batteries). The output terminals may carry live voltage even when the UPS is disconnected from an AC source.
- To reduce the risk of fire or electric shock, install this IDC in a temperature and humidity controlled, indoor environment, free of conductive contaminants. Ambient temperature must not exceed 40°C (104°F). Do not operate near water or excessive humidity (95% max). The system is not intended for outdoor use.
- Ensure all power is disconnected before performing installation or service.

CAUTION



- Batteries can present a risk of electrical shock or burn from high short-circuit current. Observe proper precautions. Servicing should be performed by qualified service personnel knowledgeable of batteries and required precautions. Keep unauthorized personnel away from batteries.
- Replace batteries with the same number and type of batteries as originally installed in the UPS.
- Proper disposal of batteries is required. Refer to local codes for disposal requirements.
- Never dispose of batteries in a fire. Batteries may explode when exposed to flame.
- Keep the IDC doors on and closed to ensure proper cooling airflow and to protect personnel from dangerous voltages inside the unit.
- Do not operate the UPS system close to gas or electric heat sources.
- The operating environment should be maintained within the parameters stated in this manual.
- Keep surroundings uncluttered, clean, and free from excess moisture.
- Do not use this equipment for other than intended use.
- Observe all DANGER, CAUTION, and WARNING notices affixed to the inside and outside of the equipment.

AVERTISSEMENT!

- Les batteries peuvent présenter un risque de décharge électrique ou de brûlure par des courts-circuits de haute intensité. Prendre les précautions nécessaires.
- Pour le remplacement, utiliser le même nombre et modèle des batteries.

ATTENTION!

- Une mise au rebut réglementaire des batteries est obligatoire. Consulter les règlements en vigueur dans votre localité.
- Ne jamais jeter les batteries au feu. L'exposition aux flammes risque de les faire exploser.

1.5 Conventions Used in This Manual

This manual uses these type conventions:

- **Bold type** highlights important concepts in discussions, key terms in procedures, and menu options.
- *Italic type* highlights notes and new terms where they are defined.
- **Screen type** represents information that appears on the screen or LCD.

Icon	Description
------	-------------



Information notes call attention to important features or instructions.

In this manual, the term *UPS* refers only to the UPS cabinet and its internal elements. The term *UPS system* refers to the entire power protection system – the UPS cabinet, the battery cabinet, the IDC, and options or accessories installed.

The term *line-up-and-match* refers to cabinets that are physically attached to the UPS, and the wiring between them is internal. The term *standalone* refers to cabinets that are not physically attached to the UPS, and are wired with external contractor-supplied wiring.

1.6 For More Information

Refer to the *Powerware 9390 UPS (40–80 kVA) Installation and Operation Manual* for the following additional information:

- UPS cabinet, optional components, and accessory installation instructions, including site preparation, planning for installation, and wiring and safety information. Detailed illustrations of cabinets and optional accessories with dimensional and connection point drawings are provided.
- UPS operation, including UPS cabinet controls, functions of the UPS, standard features and optional accessories, procedures for starting and stopping the UPS, and information about maintenance and responding to system events.
- Communication capabilities of the UPS system.

Visit www.powerware.com or contact your Eaton service representative for information on how to obtain copies of this manual.

1.7 Getting Help

If help is needed with any of the following:

- Scheduling initial startup
- Regional locations and telephone numbers
- A question about any of the information in this manual
- A question this manual does not answer

Please call the Eaton Help Desk for Powerware products at:

United States: **1-800-843-9433 or 1-919-870-3028**
Canada: **1-800-461-9166 ext 260**
All other countries: **Call your local service representative**

Section I

Installation

Chapter 2

IDC Installation Plan and Unpacking

Use the following basic sequence of steps to install the Integrated Distribution Cabinet (IDC).

1. Create an installation plan for the IDC (Chapter 2).
2. Prepare your site for the IDC (Chapter 2).
3. Inspect, unpack, and unload the IDC (Chapter 2 and 3).
4. Wire the system (Chapter 3).
5. Complete the installation checklist (Chapter 3).
6. Have authorized service personnel perform preliminary operational checks and startup.



NOTE Startup and operational checks must be performed by an authorized Eaton Customer Service Engineer, or the warranty terms as specified on page 8-1 become void. This service is offered as part of the sales contract for the UPS system. Contact your Eaton service representative in advance (usually a two-week notice is required) to reserve a preferred startup date.

2.1 Creating an Installation Plan

Before installing the IDC, read and understand how this manual applies to the system being installed. Use the procedures and illustrations in the following chapters to create a logical plan for installing the system.

2.2 Preparing the Site

For the IDC to operate at peak efficiency, the installation site should meet the environmental parameters outlined in this manual. If the IDC is to be operated at an altitude higher than 1500m (5000 ft), contact your Eaton service representative for important information about high altitude operation. The operating environment must meet the weight, clearance, and environmental requirements specified in Drawing 164201690-2 starting on page A-3 and size requirements specified in Drawing 164201690-10 starting on page A-38.

The IDC uses natural convection cooling to regulate internal component temperature. Air inlets are in the bottom of the cabinet and outlets are in the top (see Drawing 164201690-10 starting on page A-38). You must allow clearance in front of and above each IDC, and the bottom of the cabinet must be free of any obstructions for proper air circulation. See Drawing 164201690-2 on page A-3 for clearances.

2.2.1 Environmental Considerations

The life of the IDC is adversely affected if the installation does not meet the following guidelines:

1. The system must be installed on a level floor suitable for computer or electronic equipment.
2. The system must be installed in a temperature and humidity controlled indoor area free of conductive contaminants.

Failure to follow guidelines may void your warranty.

2.2.2 Preparing for Wiring the IDC



NOTE A minimum of two separate feeds with upstream feeder breakers, or one feed with two upstream feeder breakers, must be provided. One for the UPS and one for the IDC bypass input. DO NOT use one feed or a single feeder breaker to supply both the UPS and IDC.

Power and control wiring for a line-up-and-match IDC are supplied with the cabinet.

Wiring requirements, for an IDC installed separate from the UPS cabinet, including the minimum AWG size of external wiring, are specified in Drawing 164201690-5 starting on page A-12. The input power wiring connections for this equipment are rated at 90°C. If the ambient temperature is greater than 40°C, higher temperature wire and/or larger size wire may be necessary. IDC control wiring requirements are specified in Drawing 164201690-9 starting on page A-33 and should be connected at the IDC interface terminal block located inside the IDC.

2.3 Inspecting and Unpacking the IDC

The cabinet is shipped bolted to a wooden pallet and protected with outer protective packaging material (see Figure 2-1).

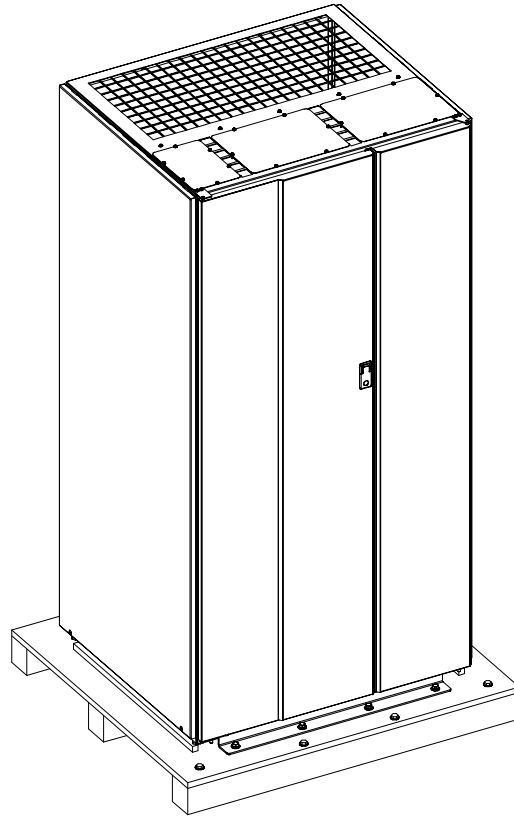

Figure 2-1. Powerware 9390 40–80 kVA IDC as Shipped on Pallet

WARNING



The IDC is heavy (see Table A on page A-3). If unpacking instructions are not closely followed, the cabinet may tip and cause serious injury.

CAUTION



- Do not install a damaged cabinet. Report any damage to the carrier and contact your Eaton service representative immediately.
- Do not tilt the IDC more than 10° from vertical or the cabinet may tip over.



NOTE Verify that the forklift or pallet jack is rated to handle the weight of the cabinet (see Table A on page A-3 for cabinet weight).

To unpack the cabinet:

1. Carefully inspect the outer packaging for evidence of damage during transit.
2. Use a forklift or pallet jack to move the packaged cabinet to the installation site, or as close as possible, before unpacking. Insert the forklift or pallet jack forks between the skids on the bottom of the unit.

3. Set the pallet on a firm, level surface, allowing a minimum clearance of 3m (10 ft) on each side for removing the cabinet from the pallet.



NOTE *The IDC is shipped with a debris shield covering the ventilation grill on top of the unit. Do not remove the debris shield until installation is complete.*

4. Remove the protective covering from the cabinet.
5. Remove the packing material, and discard or recycle in a responsible manner.
6. Inspect the contents for any evidence of physical damage, and compare each item with the Bill of Lading. If damage has occurred or shortages are evident, contact your Eaton service representative immediately to determine the extent of the damage and its impact upon further installation.



NOTE *While waiting for installation, protect the unpacked cabinet from moisture, dust, and other harmful contaminants. Failure to store and protect the IDC properly may void your warranty.*

Chapter 3

Installing the IDC

This section describes the Integrated Distribution Cabinet (IDC) installation, including: unloading the cabinet, UPS internal and external wiring, and interface connections.

3.1 Preliminary Installation Information



DANGER

This UPS contains **LETHAL VOLTAGES**. All repairs and service should be performed by **AUTHORIZED SERVICE PERSONNEL ONLY**. There are **NO USER SERVICEABLE PARTS** inside the UPS.



WARNING

Installation should be performed only by qualified personnel.

Refer to the following while installing the UPS system:

- See Appendix A for installation drawings and additional installation notes.
- Dimensions are in millimeters and inches.
- Do not tilt the cabinets more than 10° from vertical or the cabinet may tip over.
- Remove the conduit landing plates to add conduit landing holes, or remove knockouts, as required. Plate material is 16 gauge steel (1.5 mm/0.060" thick).
- The cabinets must be installed on a level floor suitable for computer or electronic equipment.
- See Table A on page A-3 for equipment weight and point loading.
- Details about control wiring are provided in each procedure. Drawing 164201690-9 and Table J, starting on page A-33, identify the control wiring terminations.
- Refer to the *Powerware 9390 UPS (40–80 kVA) Installation and Operation Manual* for UPS cabinet installation, wiring information, and conduit and terminal locations.

3.2 Unloading the Cabinet from the Pallet



WARNING

- The IDC is heavy (see Table A on page A-3). If unloading instructions are not closely followed, the cabinet may tip and cause serious injury.
- Do not install a damaged cabinet. Report any damage to the carrier and contact your Eaton service representative immediately.
- Do not tilt the IDC more than 10° from vertical or the cabinet may tip over.



NOTE Verify that the forklift or pallet jack is rated to handle the weight of the cabinet (see Table A on page A-3 for cabinet weight).

The IDC is bolted to a wooden pallet supported by wood skids.

To remove the pallet:

1. If not already moved, use a forklift or pallet jack to move the cabinet to the installation site, or as close as possible, before unloading from the pallet. Insert the forklift or pallet jack forks between the skids on the bottom of the unit.
2. Unfasten the front door latch and swing the doors open (see Figure 3-1 on page 3-3).
3. Remove the doors. Remove the retaining screws located inside each door at the top and bottom hinge pivot points, then lift the door off. Save the retaining screws for reinstallation of the doors.
4. If the leveling feet are not fully retracted, turn the leveling feet until they are retracted.
5. Remove the four bolts securing the front shipping bracket to the cabinet and the four bolts securing the bracket to the pallet (see Figure 3-1 on page 3-3). Remove the front shipping bracket.

If installing the cabinet permanently, retain the shipping bracket and securing hardware for later use.

6. Remove the four bolts securing the rear shipping bracket to the pallet (see Figure 3-2 on page 3-4). Do not remove the four bolts securing the bracket to the cabinet.
7. Remove the four front skid bolts securing the removable skid and remove the skid (see Figure 3-1 on page 3-3).

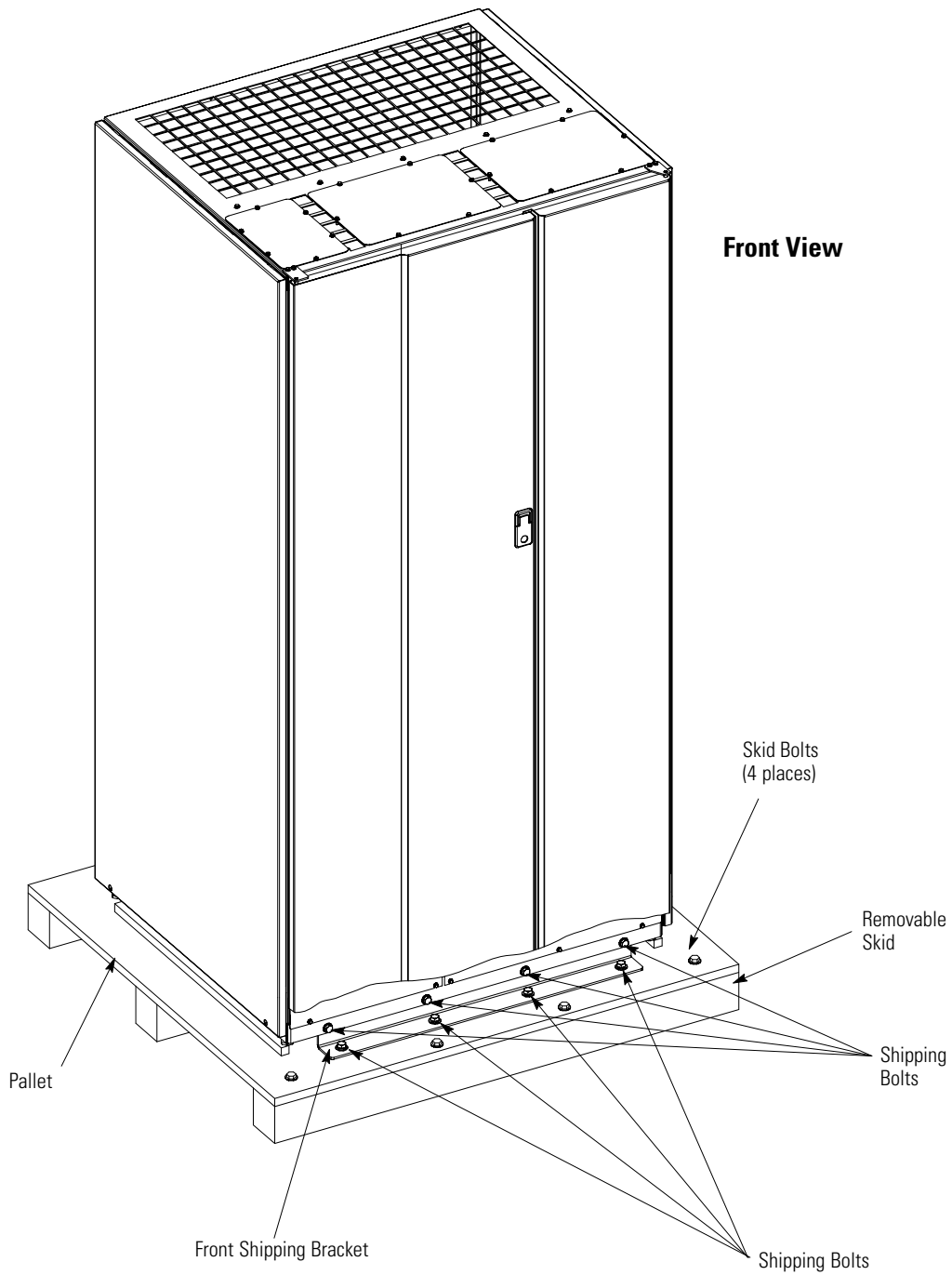

Figure 3-1. Removing the Front Shipping Bracket

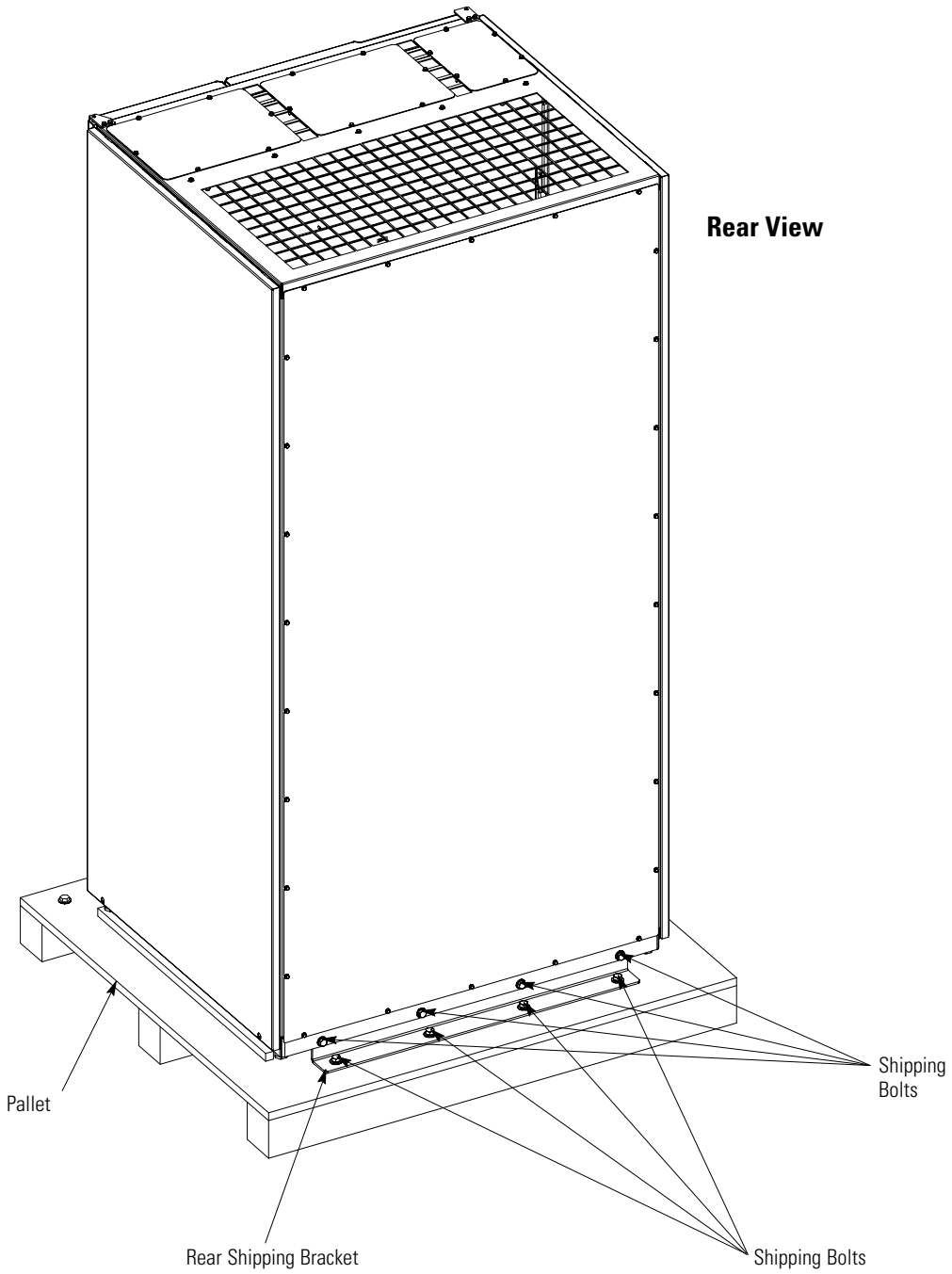

Figure 3-2. Removing the Rear Shipping Bracket



NOTE In the following step the pallet will tilt and act as a ramp when the cabinet is rolled beyond the center of the pallet. Be sure to restrain the cabinet as it continues to roll down the pallet/ramp. The rear shipping bracket will act as a brake to assist restraining the cabinet.

WARNING



Do not stand directly in front of the pallet while unloading the cabinet. If unloading instructions are not closely followed, the cabinet may cause serious injury.

8. Slowly roll the cabinet toward the front of the pallet. Once the pallet tilts, continue rolling the cabinet down the pallet until the cabinet is clear of the pallet.
9. Remove the four bolts securing the rear shipping bracket to the cabinet (see Figure 3-2 on page 3-4). Remove the rear shipping bracket.

If installing the cabinet permanently, retain the shipping brackets and securing hardware for later use.
10. Discard or recycle the pallet and unused shipping brackets in a responsible manner.
11. Roll cabinet to its final installation location.

3.3 IDC Installation

The IDC can be installed as a line-up-and-match or standalone system. The term *line-up-and-match* refers to cabinets that are physically attached to the UPS, and the wiring between them is internal. The term *standalone* refers to cabinets that are not physically attached to the UPS, and are wired with external contractor-supplied wiring.

- To install a line-up-and-match IDC, proceed to paragraph 3.3.1 on page 3-6.
- To install a standalone IDC, proceed to paragraph 3.3.2 on page 3-12.

3.3.1 Line-up-and-Match IDC Installation

To install the IDC adjacent to the Powerware 9390 UPS cabinet (see Figure 3-3 this page). The recommended location is to the right of the UPS cabinet. This procedure assumes the IDC is located to the right of the UPS cabinet.

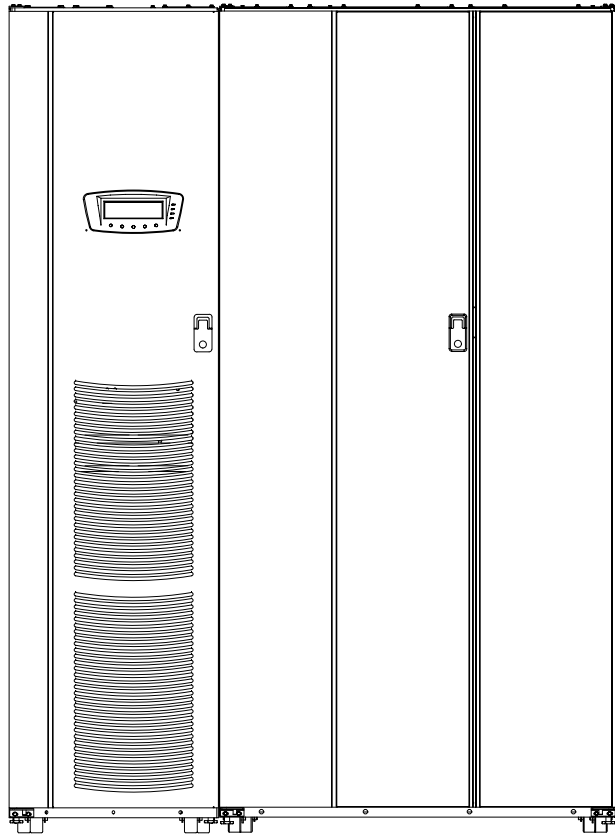

Figure 3-3. UPS with Line-up-and-Match IDC

1. Verify that the UPS is properly installed and secured. Refer to the *Powerware 9390 UPS (40–80 kVA) Installation and Operation Manual* for installation instructions.
2. Roll the IDC to an area near the right-hand side of the UPS.
3. If not already open, unfasten the front door latch and swing the doors open.
4. If not already removed, remove the doors. Remove the retaining screws located inside each door at the top and bottom hinge pivot points, then lift the door off. Save the retaining screws for reinstallation of the doors.
5. Remove the screws securing the inside distribution panel doors, and swing the doors open.
6. Remove the screws securing the top internal safety shield, and remove the shield to gain access to the top inside of the cabinet.
7. Remove the field kit and retain for later use.
8. If necessary, remove the cosmetic cover and hanger brackets from the right-hand side of the UPS. Save the cover, screws, and brackets for later use.

9. If necessary, remove the cosmetic cover and hanger brackets from the left-hand side of the IDC. Save the cover, screws, and brackets for later use.
10. Remove the knockouts, as required, on the bottom right side of the UPS cabinet inside panel. Refer to the *Powerware 9390 UPS (40–80 kVA) Installation and Operation Manual* for the location of the knockout plug.
11. Remove the knockouts on the bottom left side of the IDC inside panel (see Figure 3-4 on page 3-8).
12. Install the nylon grommets from the field kit around the holes left after removing the knockouts.
13. Push the IDC toward the UPS cabinet until the doors are flush with each other.
14. If not already installed, mount the hanger brackets to the top right side of the IDC using M4 screws (see Figure 3-4 on page 3-8).
15. If not already installed, hang the side panel on the hanger brackets and align with the front and rear of the IDC.
16. If not already secured, secure the side panel at the bottom using M4 hex-head screws previously removed.
17. If permanently mounting the IDC, proceed to Step 20; otherwise, continue to Step 18.
18. Secure the IDC in position by lowering the leveling feet until the cabinet is not resting on the casters. Verify that the cabinet is level and matches the height of the installed UPS cabinet.
19. Proceed to Step 22.
20. Using the retained hardware, reinstall the front and rear shipping brackets to the IDC with the angle facing outward (see Figure 3-1 on page 3-3 and Figure 3-2 on page 3-4).
21. Secure the cabinet to the floor with contractor-supplied hardware.

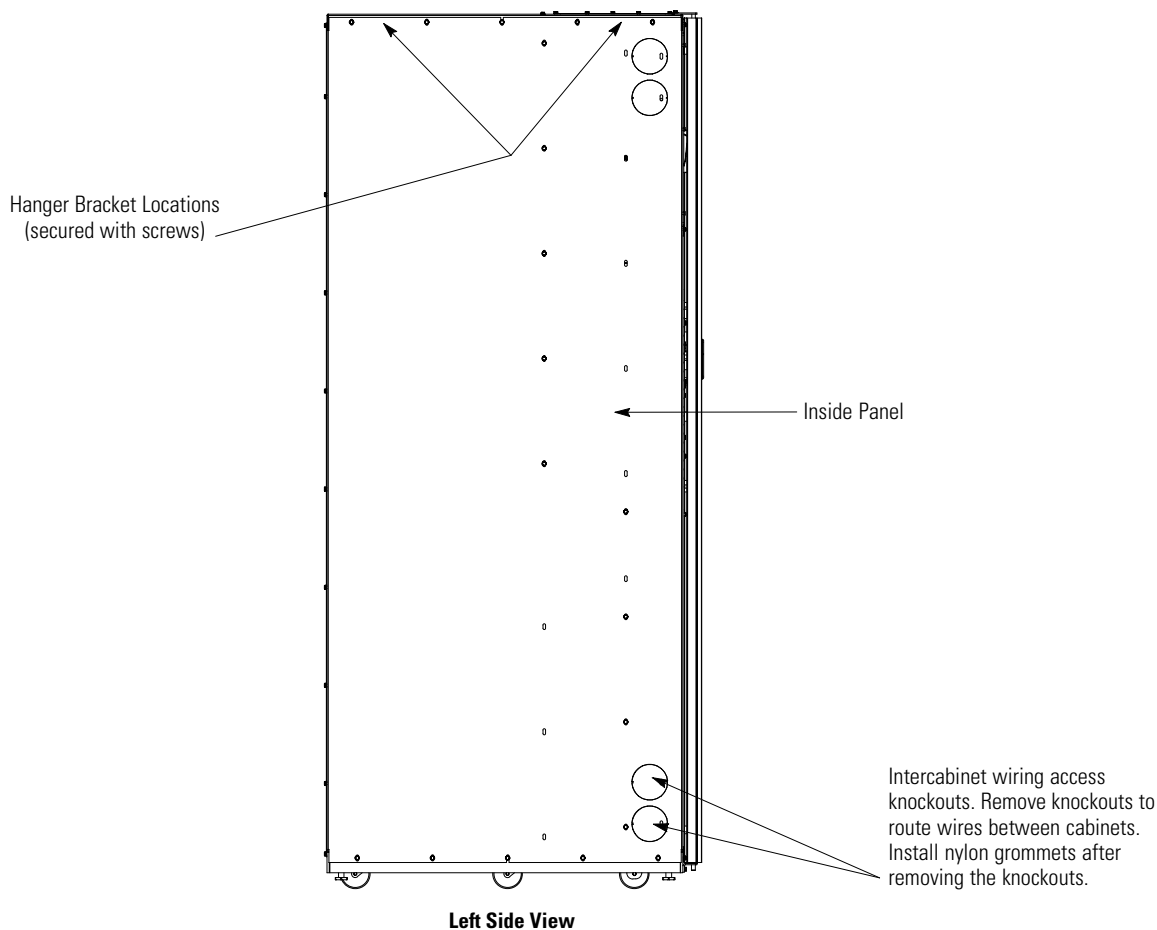

Figure 3-4. IDC Knockout Plug and Hanger Bracket Locations



NOTE Two cabinet joining brackets are provided in the field kit for securing each cabinet at the top and bottom. A small flat bracket joins the top of the cabinets and a larger angle bracket joins the cabinets at the bottom. The small flat bracket is attached to the top of the cabinets first.

22. Remove the left-hand screw from the top left-hand door hinge of the IDC.
23. Locate the small flat bracket, four washers, and M4 screw from the field kit. Align the holes in the small flat bracket over the hole in the top of the UPS cabinet and the IDC door hinge screw hole. Use the four washers between the bracket and the top of the UPS cabinet to match the IDC hinge thickness. Secure the bracket to the UPS cabinet using the M4 screw, and to the IDC hinge using the screw removed in Step 22 (see Figure 3-5 on page 3-9).
24. Locate the large angle bracket, M4 screws, and large nut from the field kit. Place one end of the bracket over the bolt on the bottom side of the lower left-hand IDC hinge, and loosely secure the bracket to the hinge with the large nut (see Figure 3-5 on page 3-9).
25. Align the holes in the other end of the bracket with the holes in the bottom right-hand side of the UPS cabinet (see Figure 3-5 on page 3-9). Secure the bracket with M4 screws from the field kit.
26. Secure the large nut on the IDC hinge.
27. Proceed to paragraph 3.3.1.1 on page 3-10.

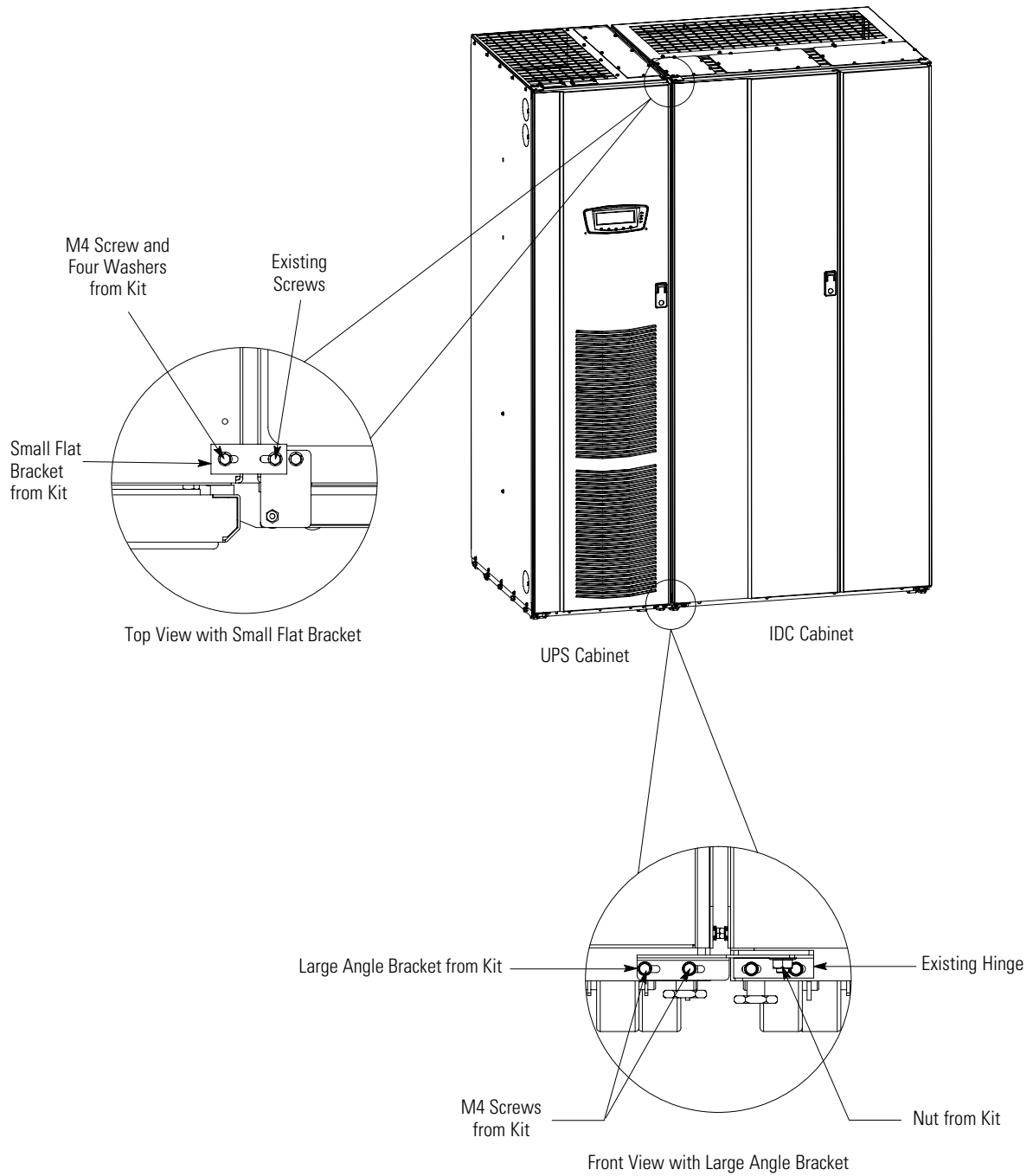

Figure 3-5. UPS to IDC Joining Brackets

3.3.1.1 Installing IDC Line-up-and-Match Power Wiring



NOTE The IDC is shipped with a debris shield covering the ventilation grill on top of the unit. Do not remove the debris shield until installation is complete. However, remove the shield before operating the IDC. Once the debris shield is removed, do not place objects on the ventilation grill.

NOTE Remove the IDC top or bottom conduit landing plate to drill or punch conduit holes, or remove knockouts (see Drawing 164201690-6 on page A-19).

NOTE Refer to the Powerware 9390 UPS (40–80 kVA) Installation and Operation Manual for UPS cabinet wiring information, and conduit and terminal locations.

1. Verify that the UPS system is turned off and all power sources are removed. Refer to the *Powerware 9390 UPS (40–80 kVA) Installation and Operation Manual* for shutdown instructions.
2. If not already open, unfasten the front door latch and swing the doors open.
3. If not already removed, remove the doors. Remove the retaining screws located inside each door at the top and bottom hinge pivot points, then lift the door off. Save the retaining screws for reinstallation of the doors.
4. If not already open, remove the screws securing the inside distribution panel doors, and swing the doors open.
5. If not already removed, remove the screws securing the top internal safety shield, and remove the shield to gain access to the terminals.
6. An IDC-to-UPS output wiring harness is supplied inside the IDC. Route this harness through the knockouts in the side of the cabinets to the UPS output terminals. Refer to the *Powerware 9390 UPS (40–80 kVA) Installation and Operation Manual* for UPS cabinet terminal locations and termination requirements. See Drawing 164201690-7, starting on page A-21, for IDC wiring access information.



NOTE A minimum of two separate feeds with upstream feeder breakers, or one feed with two upstream feeder breakers, must be provided. One for the UPS and one for the IDC bypass input. DO NOT use one feed or a single feeder breaker to supply both the UPS and IDC.

7. Connect phase A, B, and C output power wiring to the output terminals in the UPS cabinet. Connect Neutral for an IDC without a transformer. Refer to the *Powerware 9390 UPS (40–80 kVA) Installation and Operation Manual* for UPS cabinet terminal locations.
8. If wiring an IDC with a distribution panel, continue to Step 9; if wiring an IDC with distribution breakers or an output terminal block, proceed to Step 11.
9. Install customer-supplied branch circuit breakers (Cutler-Hammer Bolt-on Type BAB or QBHW) into the distribution panel.
10. Wire branch circuits according to the branch circuit breaker manufacturer's ratings and instructions, and national and local electrical codes (output is prewired to the panelboard).
11. Connect phase A, B, and C, and Neutral power wiring from output breakers or terminals and neutral terminals to the critical load.
12. After wiring the UPS system to the facility power and critical load, be sure to ground the system according to local and/or national electrical wiring codes.

13. If wiring interface connections, proceed to paragraph 3.3.1.2; otherwise, continue to Step 14.
14. When all wiring is complete, reinstall the safety shield.
15. Close the inside distribution panel doors and secure with the retained screws.
16. Reinstall the front doors.
17. Close the front doors and secure the latch.

3.3.1.2 Installing Terminal P1 Interface Connections



NOTE When installing control wiring (such as for shunt trip or aux contacts) to the IDC interface terminals, conduit must be installed between the UPS cabinet or device and the IDC, if wiring cannot be run through line-up-and-match cabinets. Install the control wiring in separate conduit from the power wiring.

1. Verify that the UPS system is turned off and all power sources are removed. Refer to the *Powerware 9390 UPS (40–80 kVA) Installation and Operation Manual* for shutdown instructions.
2. If not already open, unfasten the front door latch and swing the doors open.
3. If not already removed, remove the doors. Remove the retaining screws located inside each door at the top and bottom hinge pivot points, then lift the door off. Save the retaining screws for reinstallation of the doors.
4. If not already open, remove the screws securing the inside distribution panel doors, and swing the doors open.
5. If not already removed, remove the screws securing the top internal safety shield, and remove the shield to gain access to the terminals.
6. To install the IDC Maintenance Bypass (MBP) breaker shunt trip, remove the IDC top or bottom conduit landing plate to drill or punch conduit holes, or remove knockouts (see Drawing 164201690-6 on page A-19).
7. Reinstall the conduit landing plate and install the conduit.
8. To locate appropriate terminals, and for wiring and termination requirements, see Drawing 164201690-9, starting on page A-33, and refer to the *Powerware 9390 UPS (40–80 kVA) Installation and Operation Manual* for UPS cabinet terminal locations.
9. Route and connect the wiring.
10. When all wiring is complete, reinstall the safety shield.
11. Close the inside distribution panel doors and secure with the retained screws.
12. Reinstall the front doors.
13. Close the front doors and secure the latch.

3.3.2 Standalone IDC Installation

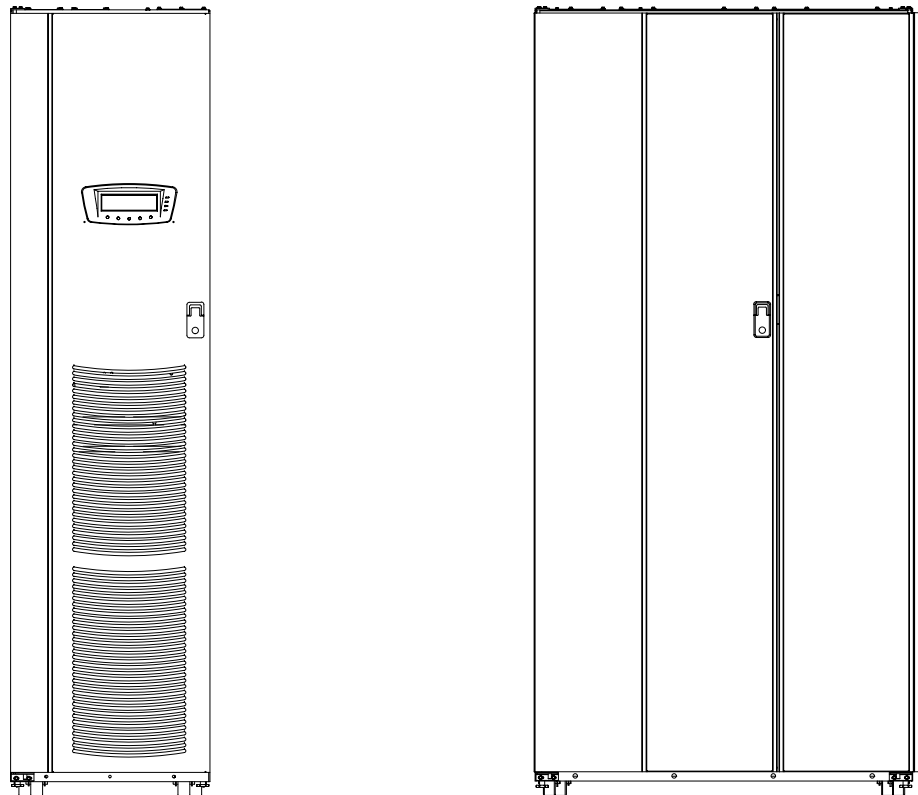

Figure 3-6. Powerware 9390 UPS with Standalone IDC

To install a separately located IDC (see Figure 3-6):

1. Verify that the UPS is properly installed and secured. Refer to the *Powerware 9390 UPS (40–80 kVA) Installation and Operation Manual* for installation instructions.
2. Roll the IDC to the area where the IDC is to be installed.
3. If not already open, unfasten the front door latch and swing the doors open.
4. If not already removed, remove the doors. Remove the retaining screws located inside each door at the top and bottom hinge pivot points, then lift the door off. Save the retaining screws for reinstallation of the doors.
5. Remove the screws securing the inside distribution panel doors, and swing the doors open.
6. Remove the screws securing the internal safety shield, and remove the shield to gain access to the inside of the cabinet.
7. If permanently mounting the IDC, proceed to Step 10; otherwise, continue to Step 8.
8. Secure the IDC in position by lowering the leveling feet until the cabinet is not resting on the casters. Verify that the cabinet is level.
9. Proceed to paragraph 3.3.2.1 on page 3-13.

10. Using the retained hardware, reinstall the front and rear shipping brackets to the IDC with the angle facing outward (see Figure 3-1 on page 3-3 and Figure 3-2 on page 3-4).
11. Secure the cabinet to the floor with contractor-supplied hardware.
12. Proceed to paragraph 3.3.2.1.

3.3.2.1 Installing IDC Standalone Power Wiring



NOTE The IDC is shipped with a debris shield covering the ventilation grill on top of the unit. Do not remove the debris shield until installation is complete. However, remove the shield before operating the IDC. Once the debris shield is removed, do not place objects on the ventilation grill.

NOTE Remove the IDC top or bottom conduit landing plate to drill or punch conduit holes, or remove knockouts (see Drawing 164201690-6 on page A-19).

NOTE Refer to the Powerware 9390 UPS (40–80 kVA) Installation and Operation Manual for UPS cabinet wiring information, and conduit and terminal locations.

1. Verify that the UPS system is turned off and all power sources are removed. Refer to the *Powerware 9390 UPS (40–80 kVA) Installation and Operation Manual* for shutdown instructions.
2. If not already open, unfasten the front door latch and swing the doors open.
3. If not already removed, remove the doors. Remove the retaining screws located inside each door at the top and bottom hinge pivot points, then lift the door off. Save the retaining screws for reinstallation of the doors.
4. If not already open, remove the screws securing the inside distribution panel doors, and swing the doors open.
5. If not already removed, remove the screws securing the top internal safety shield, and remove the shield to gain access to the terminals.



NOTE A minimum of two separate feeds with upstream feeder breakers, or one feed with two upstream feeder breakers, must be provided. One for the UPS and one for the IDC bypass input. DO NOT use one feed or a single feeder breaker to supply both the UPS and IDC.

6. Connect phase A, B, and C output power wiring to the output terminals in the UPS cabinet. Connect Neutral for an IDC without a transformer. Refer to the *Powerware 9390 UPS (40–80 kVA) Installation and Operation Manual* for UPS cabinet terminal locations.
7. If wiring an IDC with a distribution panel, continue to Step 8, if wiring an IDC with distribution breakers or an output terminal block, proceed to Step 10.
8. Install customer-supplied branch circuit breakers (Cutler-Hammer Bolt-on Type BAB or QBHW) into the distribution panel.
9. Wire branch circuits according to the branch circuit breaker manufacturer's ratings and instructions, and national and local electrical codes (output is prewired to the panelboard).
10. Connect phase A, B, and C and Neutral power wiring from output breakers or terminals and neutral terminals to the critical load.
11. After wiring the UPS system to the facility power and critical load, be sure to ground the system according to local and/or national electrical wiring codes.

12. If wiring interface connections, proceed to paragraph 3.3.2.2; otherwise, continue to Step 13.
13. When all wiring is complete, reinstall the safety shields.
14. Close the inside distribution panel doors and secure with the retained screws.
15. Reinstall the front doors.
16. Close the front doors and secure the latch.

3.3.2.2 Installing Terminal P1 Interface Connections



NOTE When installing control wiring (such as for shunt trip or aux contacts) to the IDC interface terminals, conduit must be installed between the UPS cabinet or device and the IDC. Install the control wiring in separate conduit from the power wiring.

1. Verify that the UPS system is turned off and all power sources are removed. Refer to the *Powerware 9390 UPS (40–80 kVA) Installation and Operation Manual* for shutdown instructions.
2. If not already open, unfasten the front door latch and swing the doors open.
3. If not already removed, remove the doors. Remove the retaining screws located inside each door at the top and bottom hinge pivot points, then lift the door off. Save the retaining screws for reinstallation of the doors.
4. If not already open, remove the screws securing the inside distribution panel doors, and swing the doors open.
5. If not already removed, remove the screws securing the top internal safety shield, and remove the shield to gain access to the terminals.
6. Route and connect the bypass breaker wiring from the IDC to the UPS cabinet. See Appendix A and refer to the *Powerware 9390 UPS (40–80 kVA) Installation and Operation Manual* for UPS cabinet terminal locations.
7. To install the IDC MBP breaker shunt trip, remove the IDC top or bottom conduit landing plate to drill or punch conduit holes, or remove knockouts. (see Drawing 164201690-6 on page A-19).
8. Reinstall the conduit landing plate and install the conduit.
9. To locate appropriate terminals, and for wiring and termination requirements, see Drawing 164201690-9, starting on page A-33, and refer to the *Powerware 9390 UPS (40–80 kVA) Installation and Operation Manual* for UPS cabinet terminal locations.
10. Route and connect the wiring.
11. When all wiring is complete, reinstall the safety shields.
12. Close the inside distribution panel doors and secure with the retained screws.
13. Reinstall the front doors.
14. Close the front doors and secure the latch.

3.4 Initial Startup

Startup and operational checks must be performed by an authorized Eaton Customer Service Engineer, or the warranty terms as specified on page 8-1 become void. This service is offered as part of the sales contract for the UPS system. Contact your Eaton service representative in advance (usually a two-week notice is required) to reserve a preferred startup date.

3.5 Completing the Installation Checklist

The final step in installing the IDC is completing the following installation checklist. This checklist ensures that you have completely installed all hardware, cables, and other equipment. Completing all items listed on the checklist will ensure a smooth installation. Make a copy of the installation checklist before filling it out, and retain the original.

After the installation is complete, a service representative will be able to verify the UPS system operation and commission it to support the critical load. The service representative cannot perform any installation tasks other than verifying software and operating setup parameters. Service personnel may request a copy of the completed installation checklist to verify that all applicable equipment installations have been completed.



NOTE *The installation checklist MUST be completed prior to starting the UPS system for the first time.*

Installation Checklist

- All packing materials and restraints have been removed from each cabinet.
- Each cabinet in the UPS system is placed in its final installation location.
- Shipping brackets are installed on cabinet and bolted to the floor for permanent installations.
- All conduits and cables are properly routed to the IDC.
- All power cables are properly sized and terminated.
- Distribution panel branch circuit breakers are installed and wired to the load. (OPTIONAL)
- IDC MBP breaker shunt trip signal wiring is connected from the IDC to the remote emergency power-off (REPO). (OPTIONAL)
- IDC maintenance bypass aux contact signal wiring is connected from the IDC to the UPS.
- A ground conductor is properly installed.
- Air conditioning equipment is installed and operating correctly.
- The area around the UPS system is clean and dust-free. The UPS and IDC must be installed on a level floor suitable for computer or electronic equipment.
- Adequate workspace exists around the IDC and other cabinets.
- Adequate lighting is provided around all UPS system equipment.
- A 120 Vac service outlet is located within 7.6m (25 ft) of the UPS and IDC equipment.
- The REPO device is mounted in its installed location and its wiring terminated inside the UPS and IDC. The REPO switch must be a latching-type switch with a dedicated circuit. (OPTIONAL)
- Normally-closed REPO contact (Pins 1 and 2 on TB1) jumpered if not used.
- The debris shield covering the IDC ventilation grill is removed.
- Startup and operational checks performed by an authorized Eaton Customer Service Engineer.

This page intentionally left blank.

Section II

Operation

Chapter 4

Understanding IDC Operation

4.1 UPS Mode

When the Maintenance Bypass (MBP) breaker is open and the Maintenance Isolation (MIS) breaker is closed, conditioned and protected power from the UPS is routed through the MIS to the Integrated Distribution Cabinet (IDC) 480/208V transformer.

A 480/208V transformer is provided for 480V output UPS systems. An optional 208/208 isolation transformer can also be provided for 208V output UPS systems. Power from either transformer is routed to one or two 42-pole distribution panels through a panelboard input circuit breaker. Power is then distributed to the critical loads through customer provided branch circuit breakers. If distribution panels are not installed, power is distributed through either one to six optional distribution breakers or through output terminals.

If the optional Bypass Input Breaker (BIB) and Rectifier Input Breaker (RIB) are installed, the UPS rectifier is supplied power through the RIB and the UPS bypass is supplied power through the BIB, for a dual-feed system. In a single-feed system, the RIB is not installed in the IDC. Power is supplied to the UPS through the BIB only and the UPS rectifier and bypass input terminal are jumpered together.

If a transformer is not provided, power is routed directly to the distribution panels, distribution breakers, or output terminals.

Figure 4-1 on page 4-2 shows the path of electrical power through the IDC when operating in UPS mode.

4.2 Maintenance Bypass Mode

An MBP breaker is used to safely supply utility power to the critical load during periods of UPS maintenance or repairs. The bypass source supplies the commercial AC power to the load directly.

When the MBP breaker is closed, the load is wrapped around the UPS while power is still supplied to the load by the UPS through the MIS. The MIS is then opened, isolating the UPS from the Bypass power source. The UPS can be safely shut down and power removed from the UPS without interrupting power to the critical load. If the optional BIB and RIB are installed, the BIB and RIB are opened to remove power from the UPS. Otherwise, external upstream breakers are used to remove power. The UPS now can be serviced or replaced safely.

The critical load is not protected while the UPS is in Maintenance Bypass mode.

Figure 4-2 on page 4-3 shows the path of electrical power through the IDC when operating in Maintenance Bypass mode.

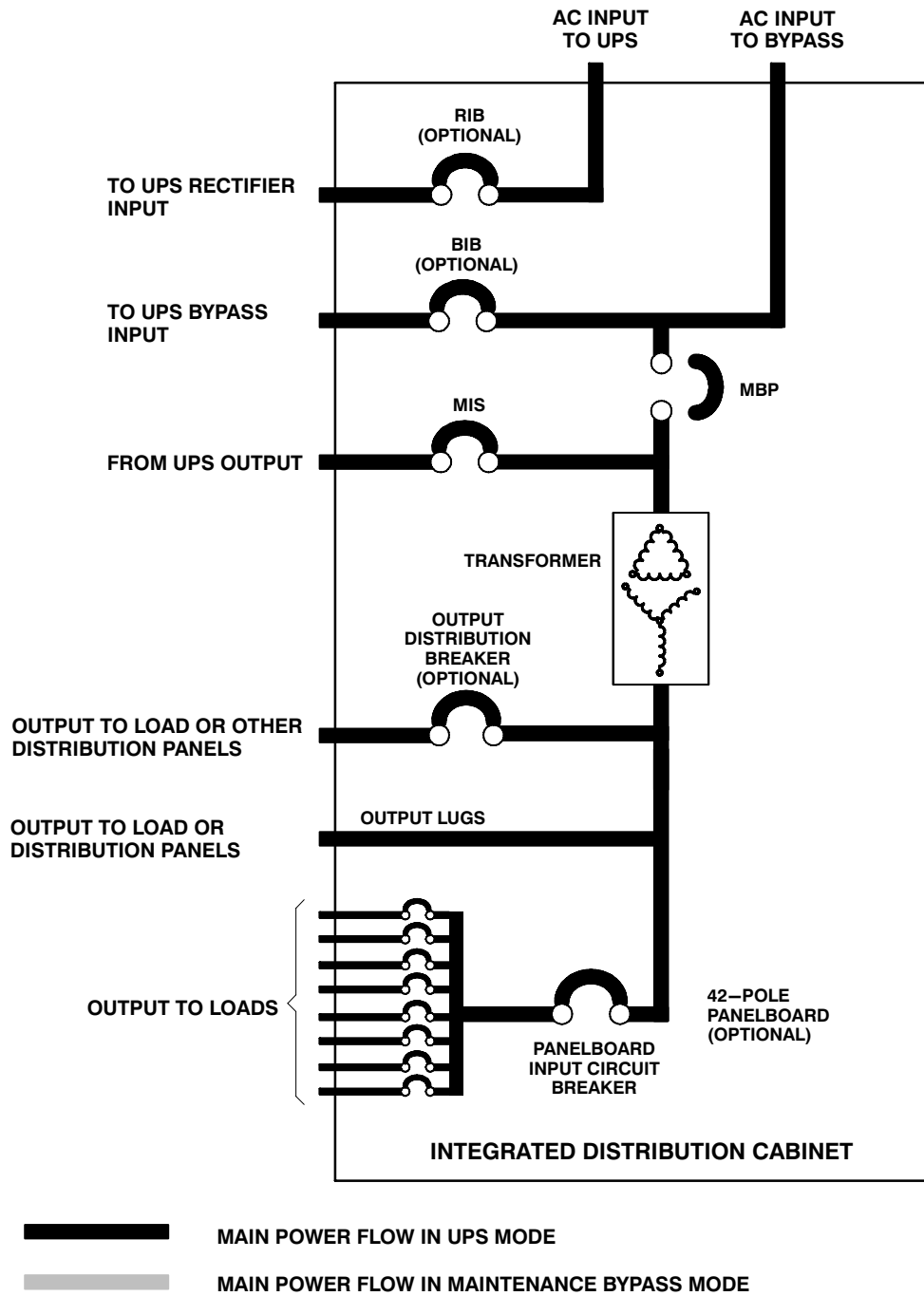

Figure 4-1. Path of Current Through the IDC in UPS Mode

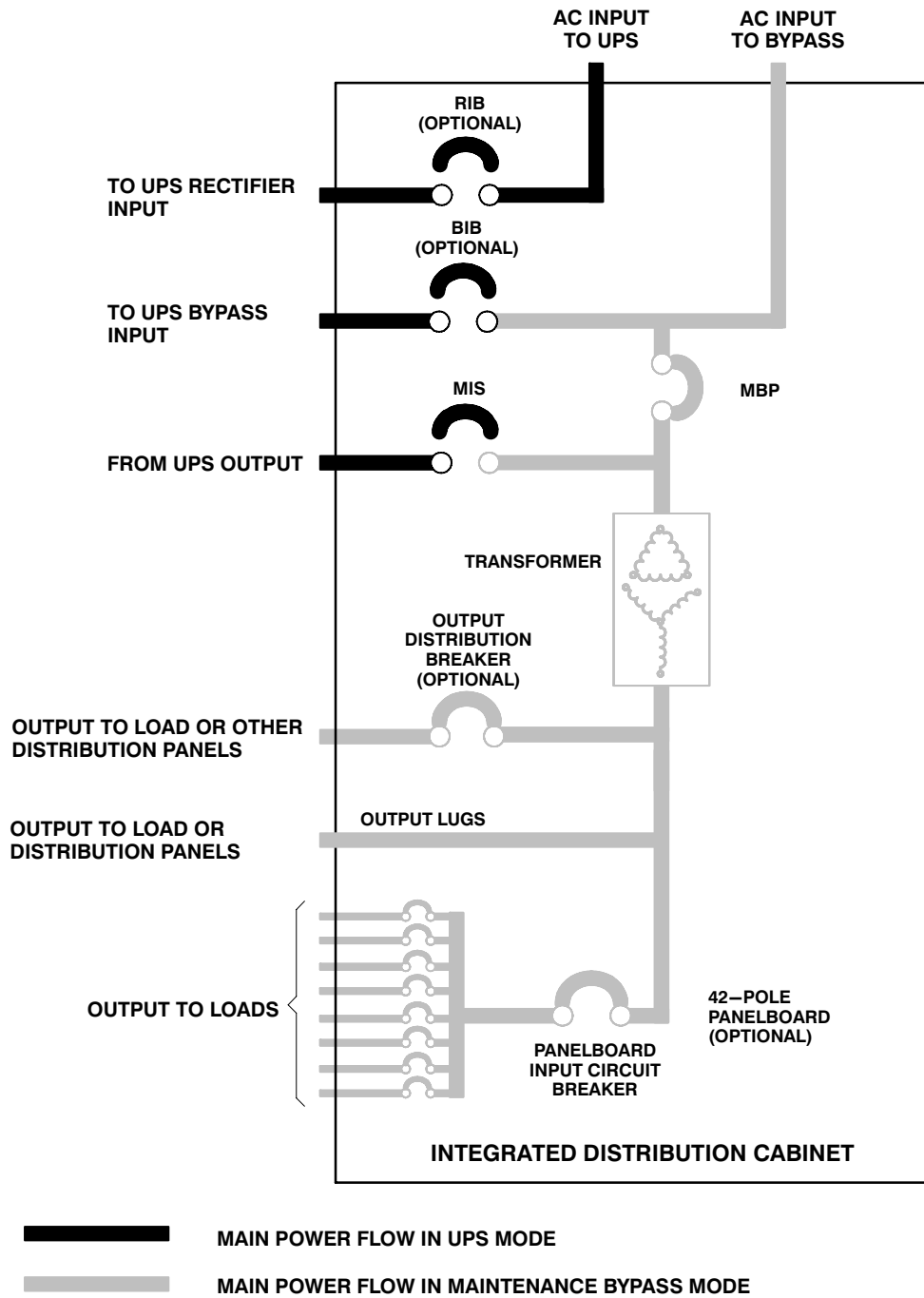

Figure 4-2. Path of Current Through the IDC in Maintenance Bypass Mode

This page intentionally left blank.

Chapter 5

IDC Controls and Operation

This chapter describes the Integrated Distribution Cabinet (IDC) controls and instructions for operating the UPS system.

5.1 IDC Controls

Figure 5-1 through Figure 5-6 identify and show the location of the controls on the Powerware 9390 40–80 kVA IDC.



NOTE *Read the operation sections of this manual and of the Powerware 9390 UPS (40–80 kVA) Installation and Operation Manual and have thorough knowledge of UPS operation before attempting to operate any of the IDC controls.*

The IDC can contain the following controls:

- Maintenance Bypass Breaker (MBP) CB1 (standard)
- Maintenance Isolation Breaker (MIS) CB2 (standard)
- Bypass Input Breaker (BIB) CB3 (optional)
- Rectifier Input Breaker (RIB) CB4 (optional)
- Distribution panels PB1 and PB2 with panel input breakers (optional)
- Distribution breakers CB11, CB12, CB13 – right side and CB21, CB22, CB23 – left side (optional)

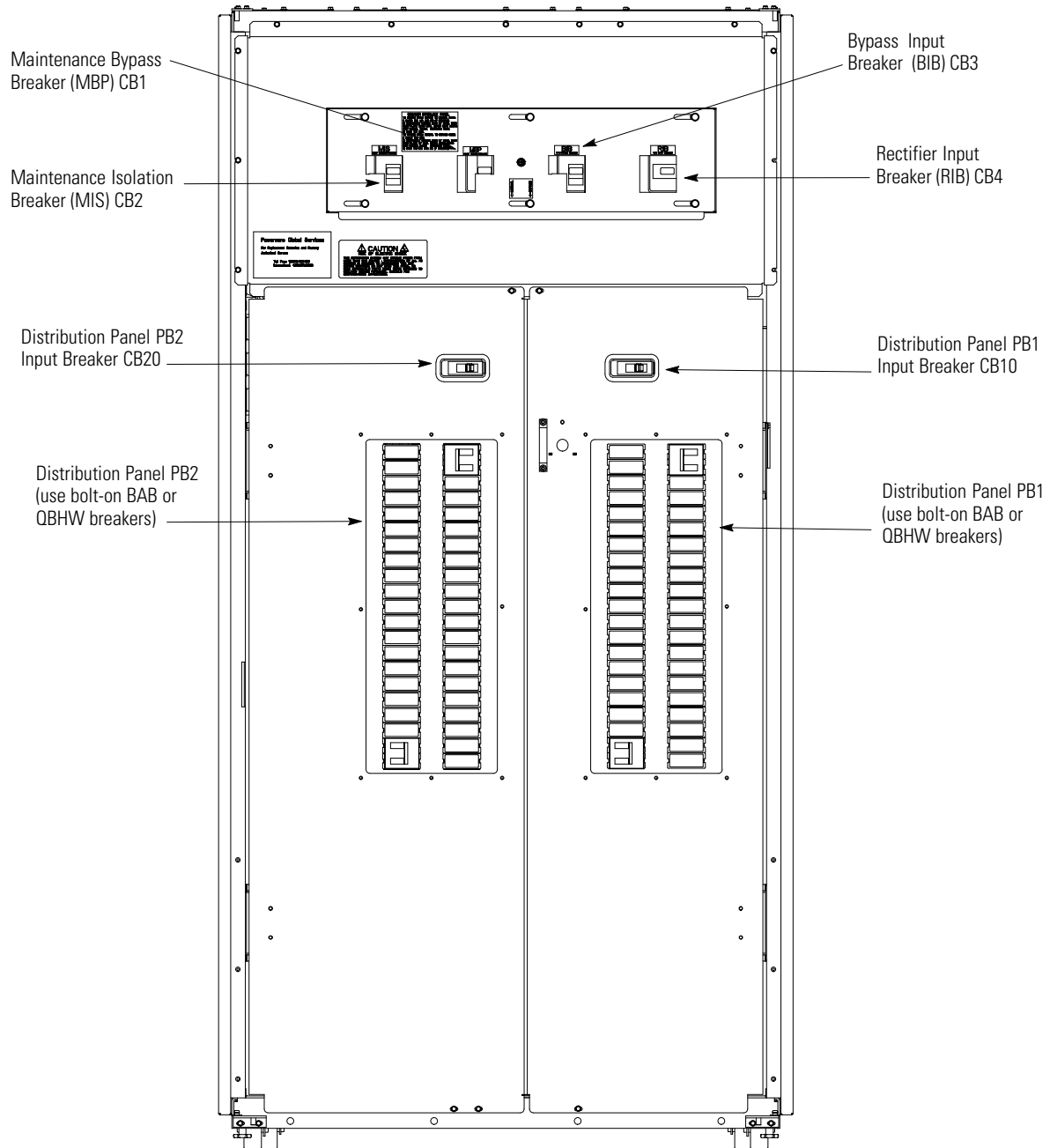

Figure 5-1. Powerware 9390 40–80 kVA IDC Controls – with Distribution Panel Option (208V)

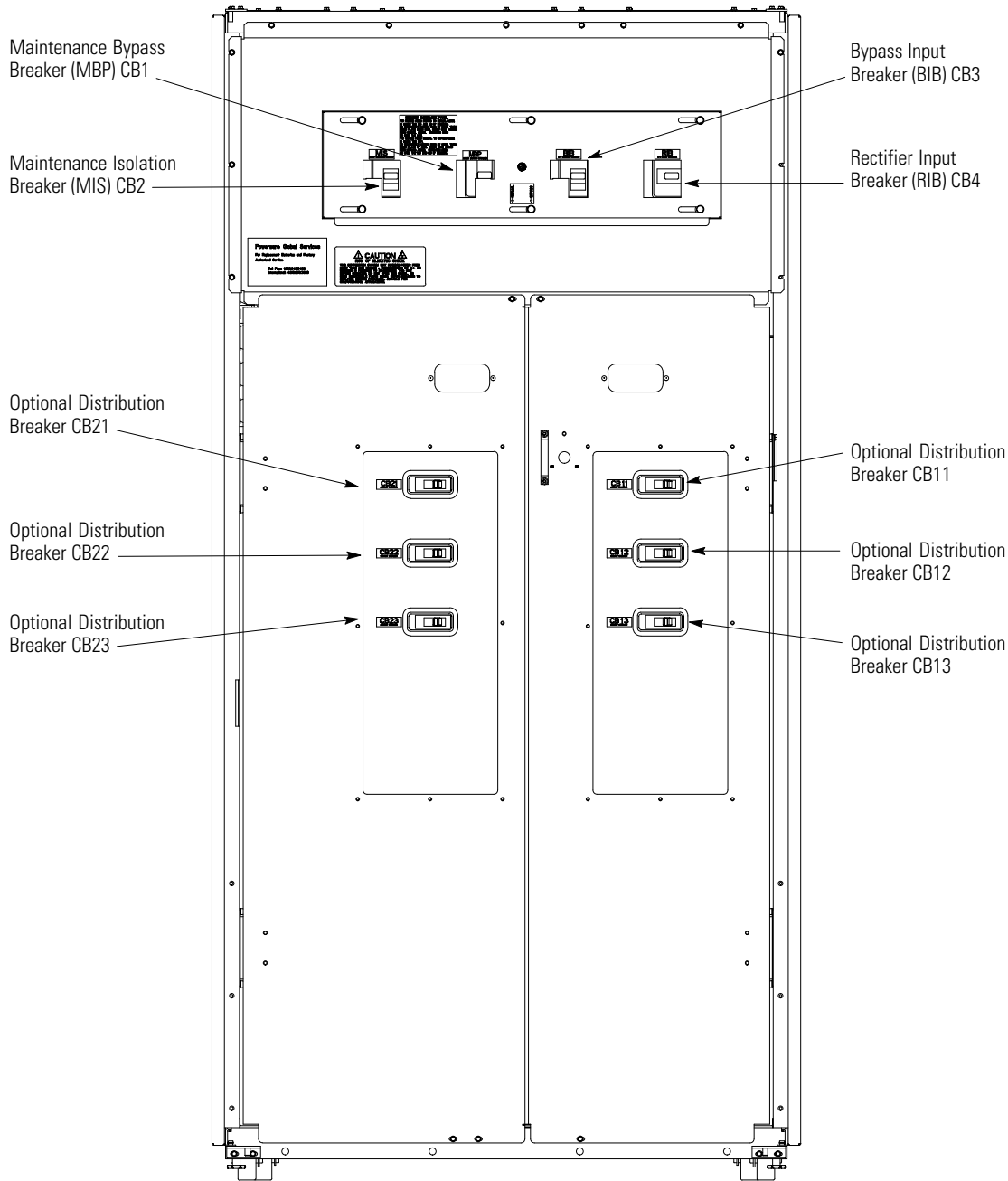

Figure 5-2. Powerware 9390 40–80 kVA IDC Controls – with Distribution Breaker Option (208V)

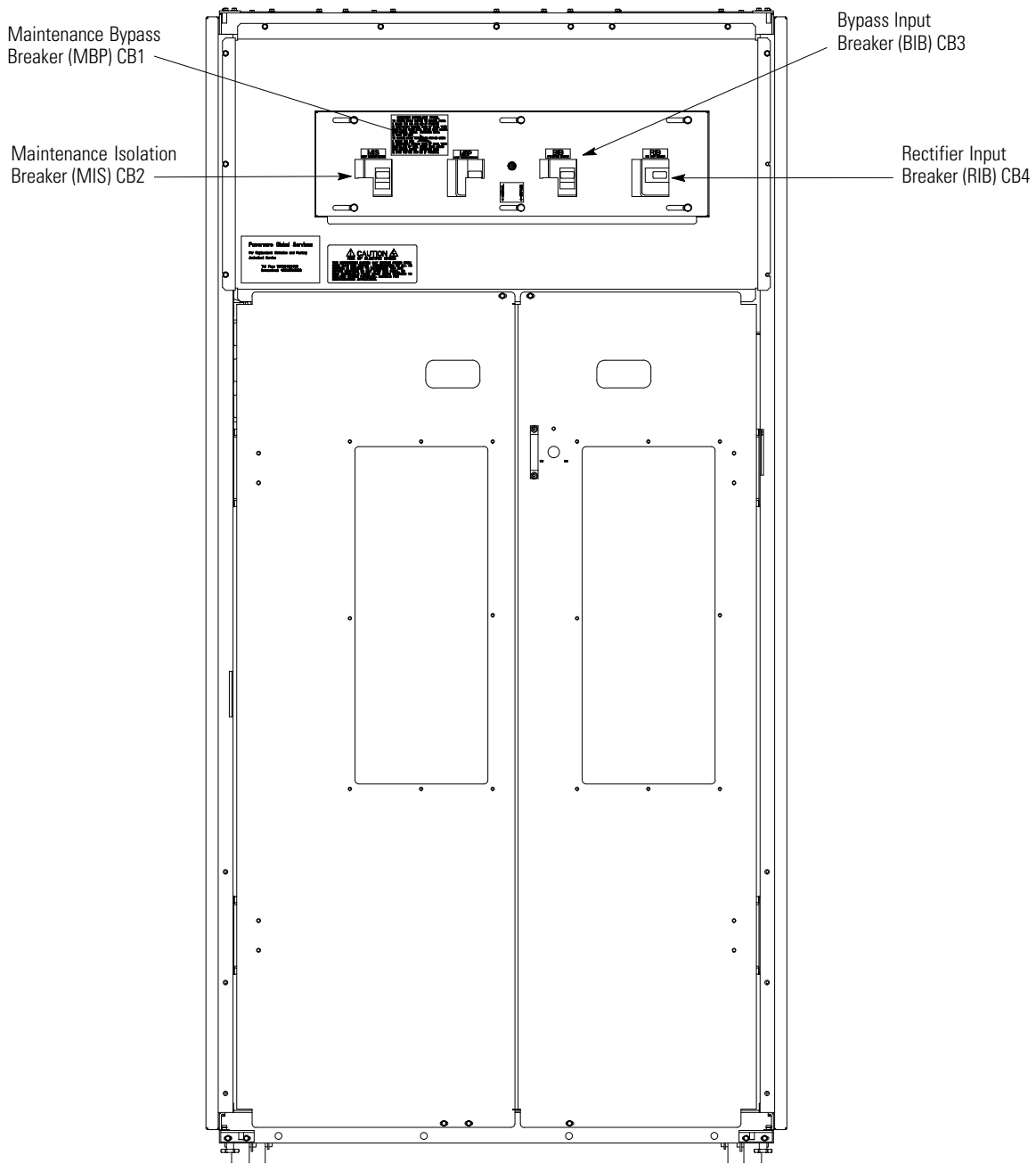

Figure 5-3. Powerware 9390 40–80 kVA IDC Controls – with No Distribution (208V)

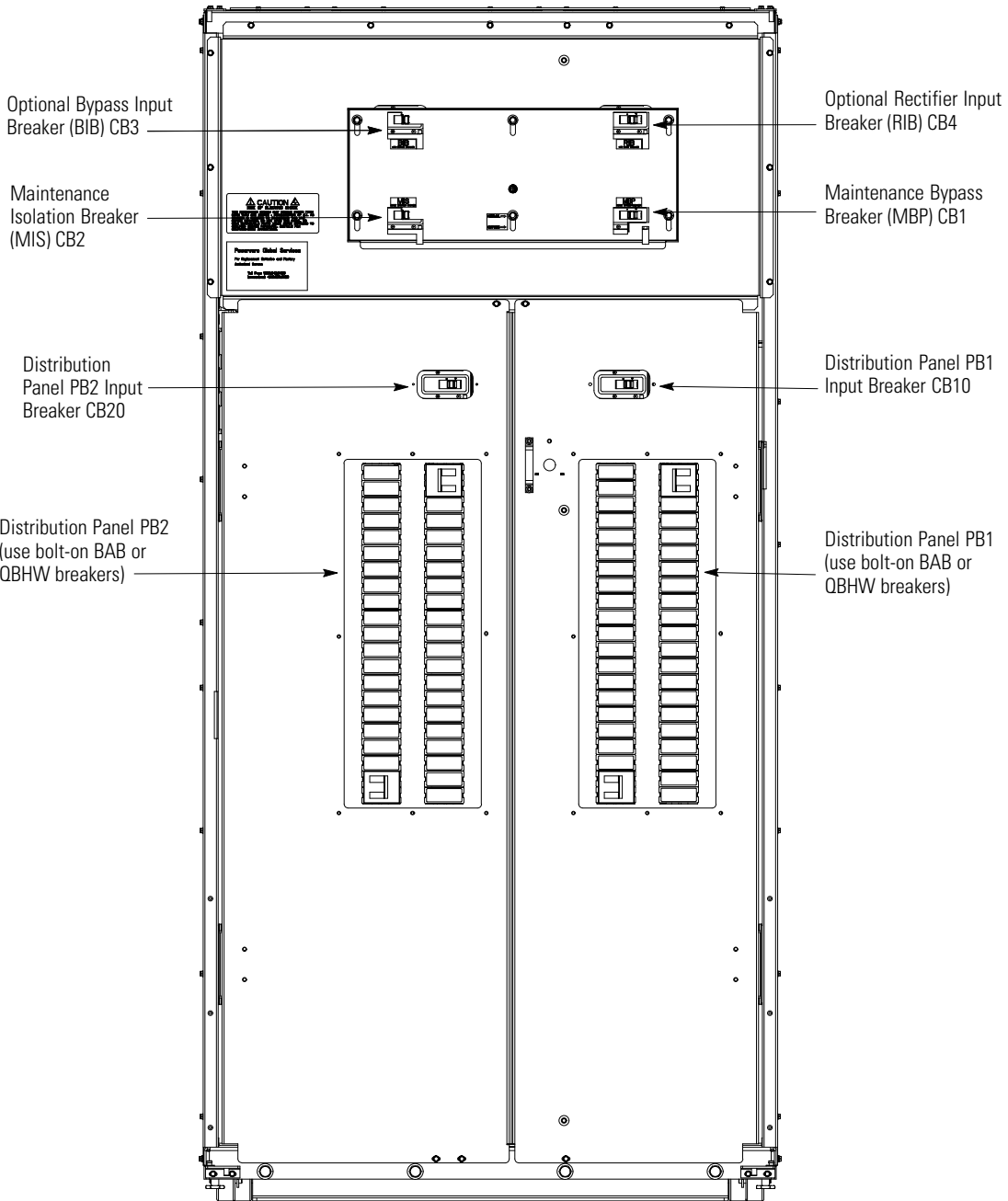

Figure 5-4. Powerware 9390 40–80 kVA IDC Controls – with Distribution Panel Option (480V)

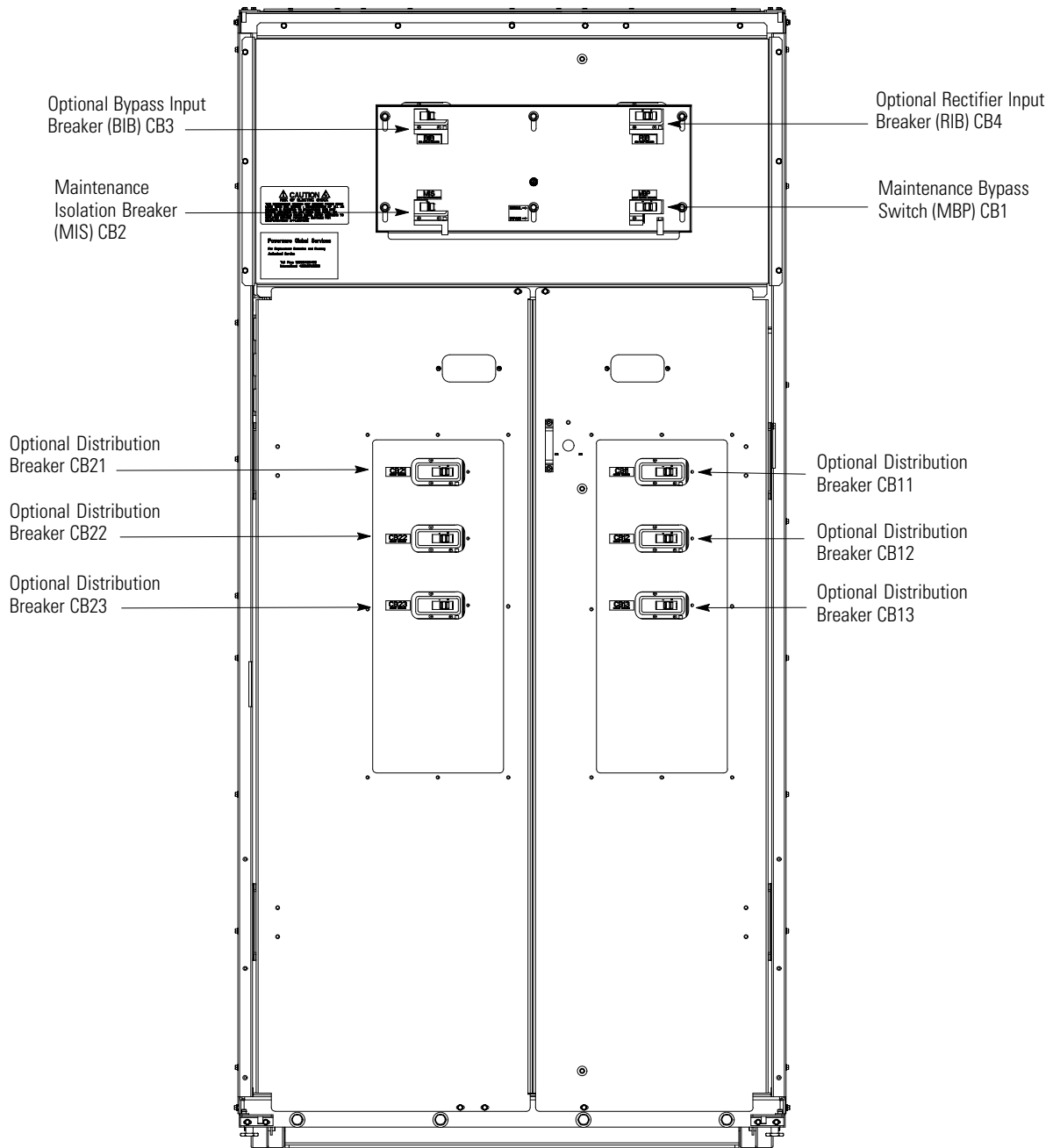

Figure 5-5. Powerware 9390 40–80 kVA IDC Controls – with Distribution Breaker Option (480V)

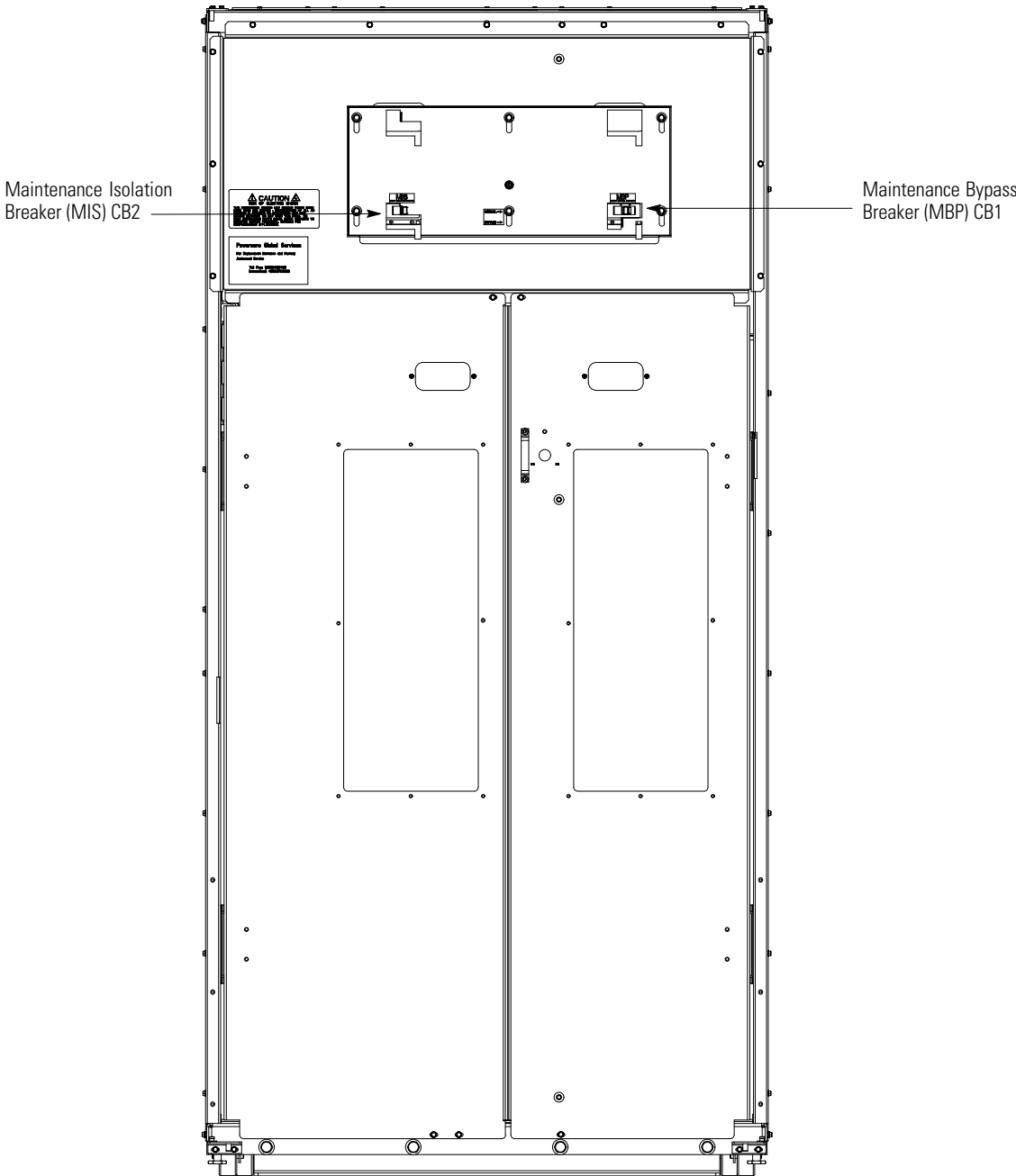

Figure 5-6. Powerware 9390 40–80 kVA IDC Controls – with No Distribution (480V)

5.2 IDC Operation



NOTE Before starting the UPS with the IDC, verify that all installation tasks are complete and an authorized Eaton Customer Service Engineer has performed a preliminary startup. The preliminary startup verifies all electrical interconnections to ensure the installation was successful and the UPS system operates properly.

5.2.1 Using the UPS when an IDC is Installed

1. Unfasten the front door latch and swing the doors open.
2. Verify that the IDC circuit breakers and switches are set as follows:

IDC MBP (CB1)	OPEN
IDC MIS (CB2)	CLOSED
IDC BIB (CB3) (if installed)	CLOSED
IDC RIB (CB4) (if installed)	CLOSED
IDC Distribution Panel Input Breakers or Distribution Breakers (if installed)	OPEN
Distribution Panel Circuit Breakers (if installed)	OPEN

3. Start the UPS in Normal mode according to the instructions in the *Powerware 9390 UPS (40–80 kVA) Installation and Operation Manual*.
4. Close the IDC MBP breaker (CB1).
5. Close the IDC distribution panel circuit input breakers (if installed) or the distribution circuit breakers (if installed).
6. Close the distribution panel branch circuit breakers (if installed).

5.2.2 Transferring the UPS to Maintenance Bypass



CAUTION

- Only trained personnel familiar with the operation of this equipment should transfer loads. Failure to follow this transfer sequence may cause loss of power to loads or overload protection devices to activate.
- In Bypass mode, the critical load is not protected from commercial power interruptions and abnormalities.

1. Press the **CONTROLS** pushbutton on the main menu bar. The System Controls screen appears.
2. Press the **BYPASS** pushbutton on the System Controls menu bar.

The UPS transfers to Bypass mode and the critical load is immediately supplied by the bypass source. If the bypass source is not available, the power processor remains on and an alarm sounds.

3. The UPS is now operating in Bypass mode and the **BYPASS** status indicator is illuminated.
4. Press the → pushbutton on the System Controls screen to display System Controls Screen 2.

5. Press the **PM OFF** pushbutton on the System Controls menu bar.

The power module (PM) status indicates SHUTDOWN. The input and output contactors open, the battery breaker or disconnect is tripped, and the PM is turned off. The bypass source supplies the critical load.



WARNING

Power is present inside the UPS cabinets.

6. Close the MBP breaker.
7. Completely loosen the interlock knob by hand (see Figure 5-7 on page 5-11).
8. Slide the interlock plate until the standoff aligns with the BYPASS arrow.
9. Tighten the interlock knob by hand.
10. Open the MIS breaker.
11. Open the BIB and RIB (if installed).

5.2.3 Transferring the UPS from Maintenance Bypass



CAUTION

Only trained personnel familiar with the operation of this equipment should transfer loads. Failure to follow this transfer sequence may cause loss of power to loads or overload protection devices to activate.

1. Close the BIB and RIB (if installed).
2. Verify that the UPS is operating and is in Bypass mode. Refer to the *Powerware 9390 UPS (40–80 kVA) Installation and Operation Manual*.
3. Close the MIS breaker.
4. Completely loosen the interlock knob by hand (see Figure 5-7 on page 5-11 on page 5-11).
5. Slide the interlock plate until the standoff aligns with the NORMAL arrow.
6. Retighten the interlock knob by hand.
7. Open the MBP breaker.
8. Transfer the UPS to Normal mode.

5.2.4 Using the Remote Emergency Power-off (REPO) Switch

An emergency power-off is initiated by the REPO pushbutton. In an emergency, you can use this switch to control the IDC and UPS output. The REPO switch opens the IDC MBP breaker, de-energizes the critical load, and powers down the UPS immediately, without asking for verification.

The UPS, including bypass, remains off until restarted.

To use the REPO switch:

CAUTION



All power to the critical load is lost when the REPO switch is activated in the following step. You should use this feature only when you want to de-energize the critical load.



NOTE *The following instructions are general instructions for activating a REPO switch. Refer to the operating instructions provided with the switch for specific instructions.*

1. Press the REPO pushbutton.

The IDC MBP breaker is tripped, the UPS input, output, and bypass backfeed contactors open, the battery breaker or disconnect is tripped, and the PM is turned off immediately, without asking for verification.

CAUTION



Do not attempt to restart the system after REPO until the cause of the shutdown has been identified and cleared.

2. To restart the UPS after using the REPO pushbutton, reset the REPO switch and then follow the procedures in the *Powerware 9390 UPS (40–80 kVA) Installation and Operation Manual*.

MAINTENANCE BYPASS POSITION
(plate in far LEFT position)

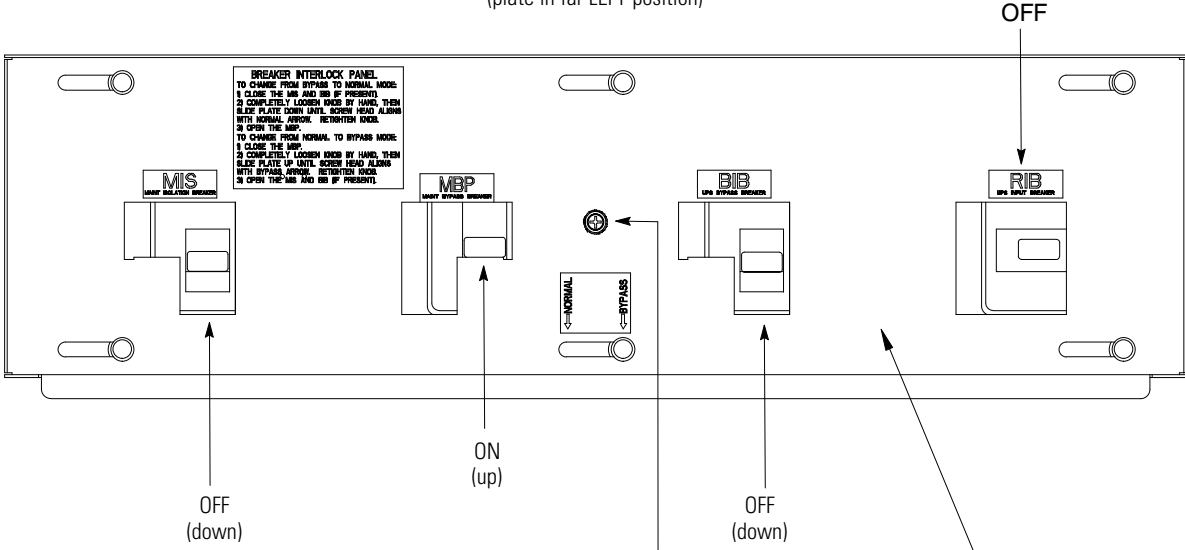

NORMAL OPERATION POSITION
(plate in far RIGHT position)

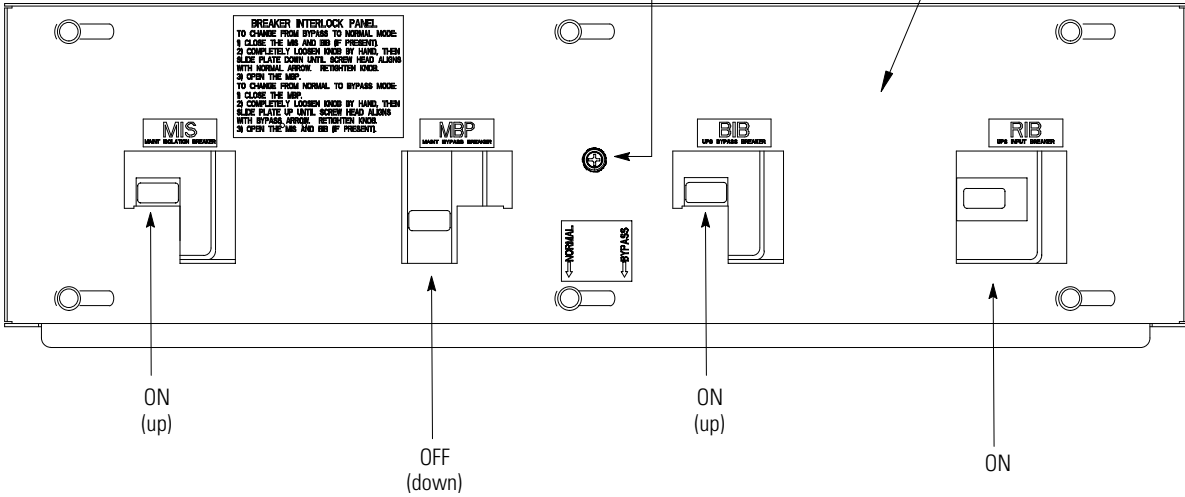

Figure 5-7. Powerware 9390 IDC Controls - Interlock Operation (208V)

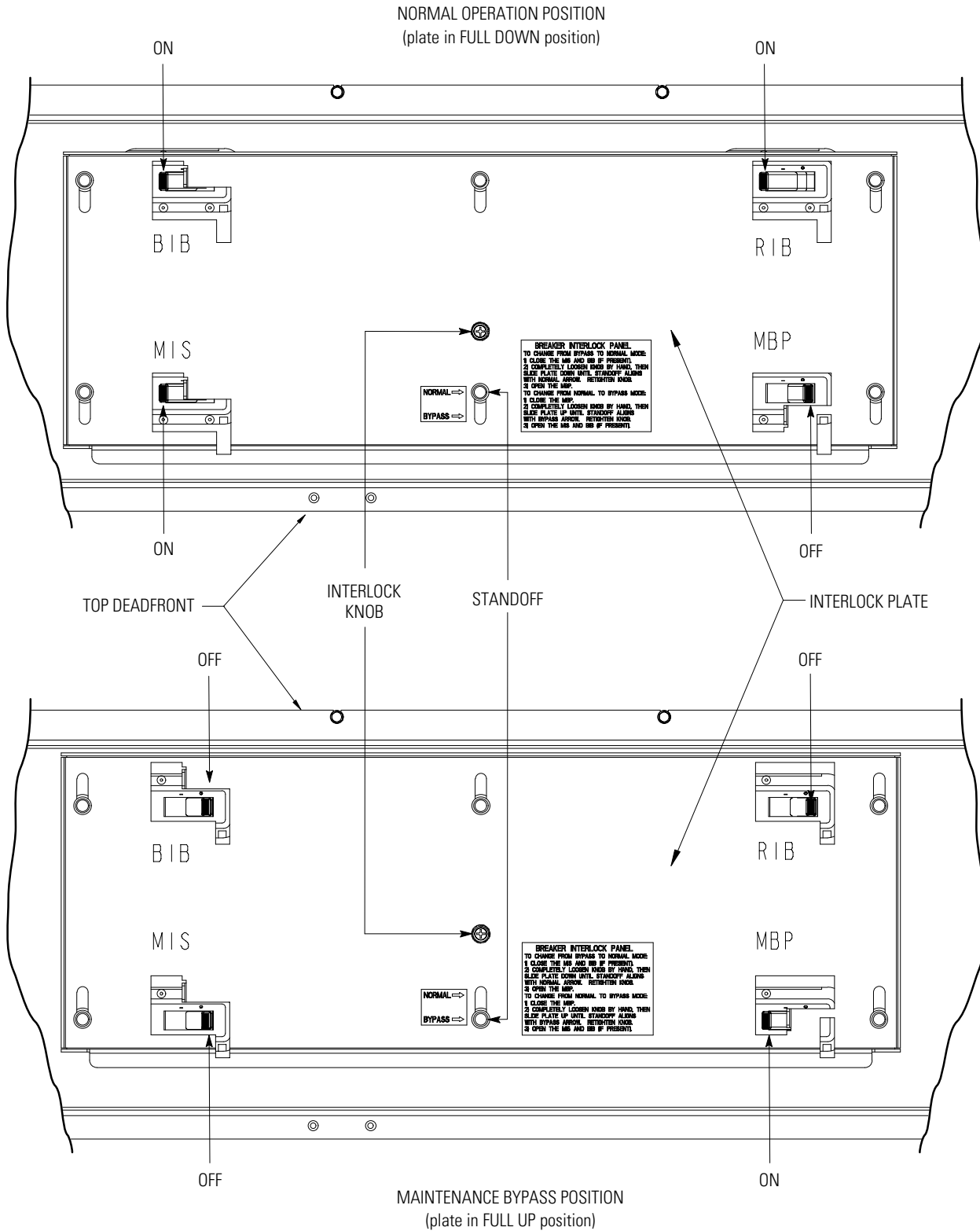

Figure 5-8. Powerware 9390 IDC Controls - Interlock Operation (480V)

Chapter 6

Maintaining the IDC

The components inside the Integrated Distribution Cabinet (IDC) are secured to a sturdy metal frame. All repairable parts and assemblies are located for easy removal, with very little disassembly. This design allows authorized service personnel to perform routine maintenance and servicing quickly.

6.1 Important Safety Instructions

Remember that the UPS system is designed to supply power **EVEN WHEN DISCONNECTED FROM THE UTILITY POWER**. The IDC interior is unsafe until the UPS is shut down (inverter output and bypass) and bypass utility power to the IDC is disconnected.



DANGER

This UPS contains **LETHAL VOLTAGES**. All repairs and service should be performed by **AUTHORIZED SERVICE PERSONNEL ONLY**. There are **NO USER SERVICEABLE PARTS** inside the UPS.



WARNING

- Servicing and maintenance should be performed by qualified service personnel only.
- **LETHAL VOLTAGE PRESENT**. DO NOT operate with the cabinet doors open or protective panels removed. Do not make any assumptions about the electrical state of any cabinet in the UPS system.
- See "Safety Warnings" on page 1-4.

6.2 Performing Preventive Maintenance

The IDC requires very little preventive maintenance. However, inspect the IDC periodically to verify that the unit is operating normally.

6.2.1 Daily Maintenance

Perform the following steps daily:

1. Check the area surrounding the IDC. Verify that the area is not cluttered, allowing free access to the unit.
2. Verify that the air intakes (vents on the bottom of the IDC) and exhaust opening (on top of the IDC) are not blocked.
3. Verify that the operating environment is within the parameters specified in Chapter 7, "Product Specifications" and Drawing 164201690-2 starting on page A-3.
4. Record the results of your checks and any corrective actions in a suitable log.

6.2.2 Periodic Maintenance

Periodic inspections of the IDC should be made to determine if components, wiring, and connections exhibit evidence of overheating. Particular attention should be given to bolted connections. Maintenance procedures should specify that the bolted connections be retorqued to values listed on labels posted on the equipment.

Refer to the distribution panel manufacturer's circuit breaker application and maintenance literature for recommended maintenance practices and procedures.

6.2.3 Annual Maintenance

Annual preventive maintenance, if required, should be performed only by authorized service personnel familiar with maintenance and servicing of the UPS system. Contact your Eaton service representative for more information about service offerings.

6.3 Short Circuits

Short circuits are not considered normal phenomena in UPS applications. Tripping of protective devices due to low impedance short circuits should be thoroughly investigated for damage to conductors, insulation, and the protective devices according to the manufacturer's recommendations.

6.4 Maintenance Training

A basic training course, available from Eaton, gives you a competent working knowledge of the UPS system operation and teaches you how to perform first level corrective maintenance. For more information about training and other services, contact the Eaton Help Desk for Powerware products (see page 1-6).

Chapter 7

Product Specifications

The following sections detail the input, output, and environmental specifications for the Integrated Distribution Cabinet (IDC).

7.1 Model Numbers

The IDC is housed in a free-standing cabinet with safety shields behind the doors.

System	Model	Frequency
Powerware 9390	40–80 kVA	60 Hz

7.2 IDC Input

Operating Input Voltage (Nominal +10/–15%)	208 Vac nominal (60 Hz) 480 Vac nominal (60 Hz)
Operating Input Frequency Range	±5 Hz
Operating Input Current	See Table D or Table E starting on page A-12

7.3 IDC Output

Operating Output Voltage (Nominal +10/–15%)	208 Vac nominal (60 Hz) 480 Vac nominal (60 Hz)
Operating Output Frequency Range	±5 Hz
Output Current	See Table D or Table E starting on page A-12

7.4 Environmental Specifications

Operating Temperature	0 to 40°C (32 to 104°F) without derating. The recommended operating temperature is 25°C (77°F).
Operating Altitude	Maximum 1500m (5000 ft) at 40°C (104°F) without derating
Storage Temperature	-25 to 60°C (-13 to 140°F)
Relative Humidity (Operating and Storage)	5% to 95% maximum noncondensing
Acoustical Noise	N/A
EMI Suppression	N/A
Electrostatic Discharge (ESD) Immunity	N/A

This page intentionally left blank.

Chapter 8

Warranty

Limited Factory Warranty

Three-Phase Powerware® UPS Products

WARRANTOR: The warrantor for the limited warranties set forth herein is Eaton Electrical Inc., a Delaware Corporation (“Eaton”).

LIMITED WARRANTY: This limited warranty (this “Warranty”) applies only to the original end-user (the “End-User”) of the Powerware Three-Phase UPS Products (the “Product”) and cannot be transferred. This Warranty applies even in the event that the Product is initially sold by Eaton for resale to an End-User.

LIMITED WARRANTY PERIOD: The period covered by this Warranty for Product installed [and currently located] in the fifty (50) United States and the District of Columbia is twelve (12) months from the date of Product startup or eighteen (18) months from the date of Product shipment, whichever occurs first, for parts coverage and 90 days from the date of Product startup for labor coverage. The period covered by this Warranty for Product installed [and currently located] outside of the fifty (50) United States and the District of Columbia is twelve (12) months from the date of Product startup or eighteen (18) months from the date of Product shipment, whichever occurs first, for parts coverage.

WHAT THIS LIMITED WARRANTY COVERS: The warrantor warrants that the Powerware three-phase UPS electronics, Eaton-built accessories, and Powerware-built battery cabinets (individually and collectively, the “Warranted Items”) are free from defects in material and workmanship. If, in the opinion of Eaton, a Warranted Item is defective and the defect is within the terms of this Warranty, Eaton’s sole obligation will be to repair or replace such defective item (including by providing service, parts, and labor, as applicable), at the option of Eaton. The Warranted Item will be repaired or replaced onsite at the End-User’s location or such other location as determined by Eaton. Any parts that are replaced may be new or reconditioned. All parts replaced by Eaton shall become the property of Eaton.

WHAT THIS LIMITED WARRANTY DOES NOT COVER: This Warranty does not cover any defects or damages caused by: (a) failure to properly store the Product before installation, including the “trickle charge” of batteries no later than the date indicated on the packaging; (b) shipping and delivery of the Product if shipping is FOB Factory; (c) neglect, accident, fire, flood, lightning, vandalism, acts of God, Customer’s neglect, abuse, misuse, misapplication, incorrect installation; (d) repair or alteration not authorized in writing by Eaton personnel or performed by an authorized Eaton Customer Service Engineer or Agent; or (e) improper testing, operation, maintenance, adjustment, or any modification of any kind not authorized in writing by Eaton personnel or performed by an authorized Eaton Customer Service Engineer or Agent.

This Warranty is not valid: (a) unless an authorized Eaton Customer Service Engineer (in the USA) or Agent (outside of the USA) performs startup and commissioning of the Product; (b) if the Product is moved to a new location by someone other than an authorized Eaton Customer Service Engineer (in the USA) or Agent (outside of the USA); or (c) if the Product’s serial numbers have been removed or are illegible. Any Warranted Items repaired or replaced pursuant to this Warranty will be warranted for the remaining portion of the original Warranty subject to all the terms thereof. Labor warranty is not provided for Product located outside of the fifty (50) United States or the District of Columbia. **Any equipment, parts, or materials included in the Product and not manufactured by Eaton are warranted solely by the manufacturer of such equipment, parts, or materials and are not included as part of this Warranty. Batteries are not warranted by Eaton.**

THIS WARRANTY IS THE END-USER’S SOLE REMEDY AND IS EXPRESSLY IN LIEU OF, AND THERE ARE NO OTHER EXPRESSED OR IMPLIED GUARANTEES OR WARRANTIES (INCLUDING ANY IMPLIED WARRANTY OF MERCHANTABILITY OR FITNESS FOR ANY PURPOSE, WHICH ARE EXPRESSLY DISCLAIMED).

LIMITATION OF LIABILITY: In no event shall Eaton be liable for any indirect, incidental, special, or consequential damages of any kind or type whatsoever, or based on any claim or cause of action, however denominated. Eaton shall not be responsible for failure to provide service or parts due to causes beyond Eaton’s reasonable control. In no case will Eaton’s liability under this Warranty exceed the replacement value of the Warranted Items.

END-USER’S OBLIGATIONS: In order to receive the benefits of this Warranty, the End-User must use the Product in a normal way, follow the Product’s user’s guide, and protect against further damage to the Product if there is a covered defect.

OTHER LIMITATIONS: Eaton’s obligations under this Warranty are expressly conditioned upon receipt by Eaton of all payments due to it (including interest charges, if any). During such time as Eaton has not received payment of any amount due to it for the Product, in accordance with the contract terms under which the Product is sold, Eaton shall have no obligation under this Warranty. Also during such time, the period of this Warranty shall continue to run and the expiration of this Warranty shall not be extended upon payment of any overdue or unpaid amounts.

COSTS NOT RELATED TO WARRANTY: The End-User shall be invoiced for, and shall pay for, all services not expressly provided for by the terms of this Warranty, including without limitation site calls involving an inspection that determines no corrective maintenance is required. Any costs for replacement equipment, installation, materials, freight charges, travel expenses, or labor of Eaton representatives outside the terms of this Warranty will be borne by the End-User.

OBTAINING WARRANTY SERVICE: In the USA, call the Eaton Customer Reliability Center 7x24 at 800-843-9433. Outside of the USA, call your local Eaton sales or service representative, or call the Eaton Customer Reliability Center in the USA at 919-870-3028. For comments or questions about this Limited Factory Warranty, write to the Customer Quality Representative, 3301 Spring Forest Road, Raleigh, North Carolina 27616 USA.

This page intentionally left blank.

Appendix A

Installation Reference

The information in this appendix will help during the planning and installation of the Integrated Distribution Cabinet (IDC). This appendix contains the following drawings:

- 164201690-1 Typical Powerware 9390 UPS System with Integrated Distribution Cabinet
- 164201690-2 Physical Features and Requirements
- 164201690-3 IDC Oneline Drawings
- 164201690-4 IDC Distribution Panel Schematic
- 164201690-5 Power Wiring Installation Notes
- 164201690-6 Conduit and Wire Entry Locations
- 164201690-7 IDC Power Terminal Locations (208V)
- 164201690-8 IDC Power Terminal Locations (480V)
- 164201690-9 Interface and Control Wiring Installation Notes and Terminal Locations
- 164201690-10 IDC Dimensions

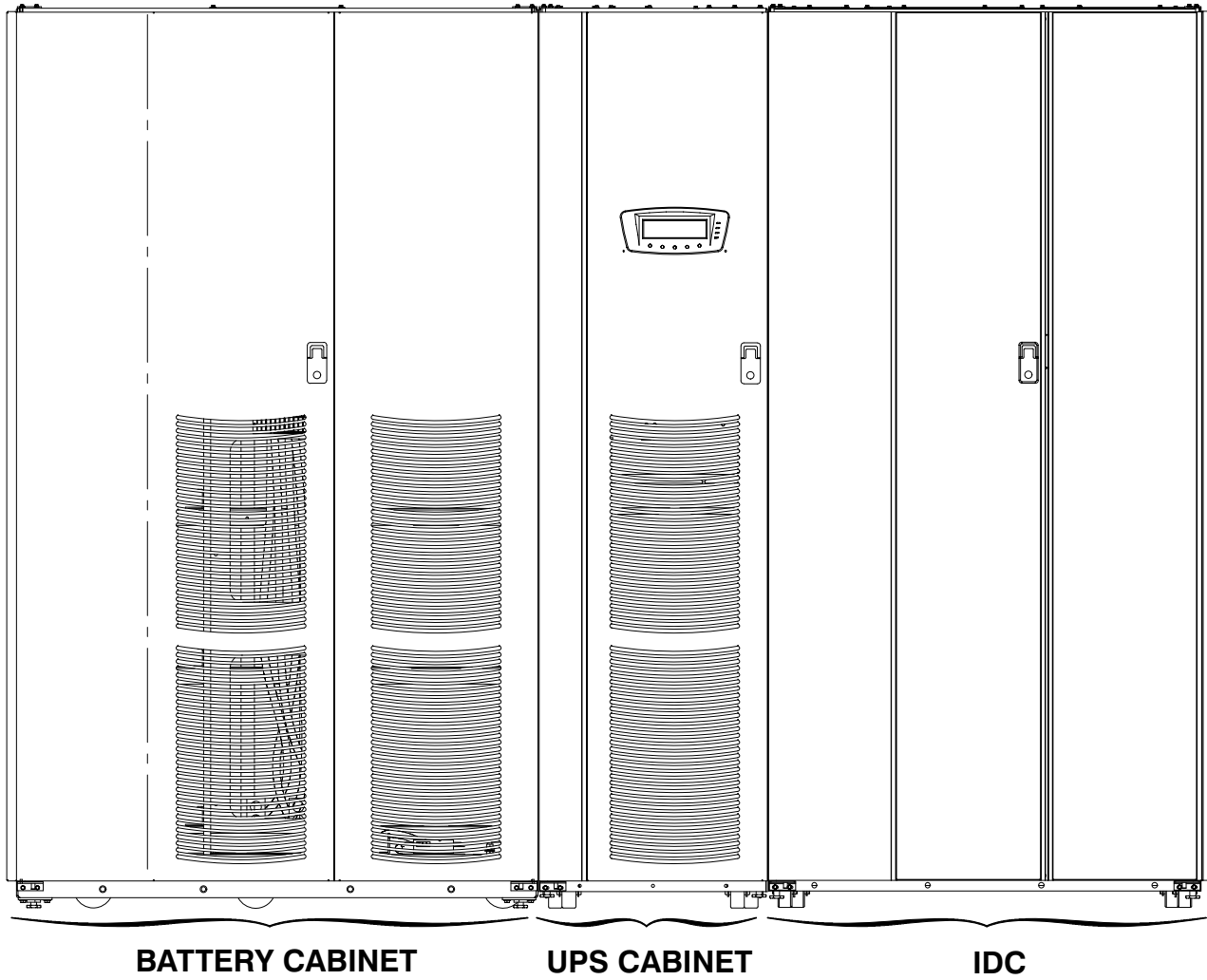

DESCRIPTION: TYPICAL Powerware 9390 UPS SYSTEM WITH INTEGRATED DISTRIBUTION CABINET	
DRAWING NO: 164201690-1	SHEET: 1 of 1
REVISION: A	DATE: 050107

1. The IDC equipment operating environment must meet the weight requirements shown in Table A and size requirements shown in Drawing 164201690–10.
2. The IDC is palletted separately for shipping.
3. Do not tilt cabinets more than 10° from vertical or they may tip over.
4. Dimensions are in millimeters (inches).

Table A. Equipment Weight			
<i>Component/Model</i>	<i>Weight kg (lb)</i>		
	<i>Shipping</i>	<i>Installed</i>	<i>Point Loading</i>
Powerware 9390 40–80 kVA IDC with Maintenance Bypass Breaker (MBP) and Maintenance Input Breaker (MIS)	236 (520)	213 (470)	6 at 35.5 (78.3)
NOTES: 1. For IDC with Transformer, add 331 kg (730 lb). 2. For IDC with Distribution Panels, add 11.3 kg (25 lb) for each panel. 3. For IDC with Distribution Breakers, add 6.8 kg (15 lb) for each breaker. 4. For IDC with Output Lugs, add 2.3 kg (5 lb).			

5. The clearances required around the IDC are shown in Table B.

Table B. IDC Clearances	
From Top of Cabinet	Minimum clearance over the IDC is 457.2 mm (18") for ventilation
From Front of Cabinet	914.4 (36") for working space
From Back of Cabinet	None Required
From Right Side of Cabinet	None Required
From Left Side of Cabinet	152 mm (6") for door swing

<i>DESCRIPTION:</i> PHYSICAL FEATURES AND REQUIREMENTS	
<i>DRAWING NO.:</i> 164201690–2	<i>SHEET:</i> 1 of 2
<i>REVISION:</i> A	<i>DATE:</i> 050107

6. The basic environmental requirements for operation of the IDC are:

Ambient Temperature Range: 0–40°C (32–104°F)

Recommended Operating Range: 20–25°C (68–77°F)

Maximum Relative Humidity: 95%, noncondensing

The IDC ventilation requirements are shown in Table C.

Table C. Air Conditioning or Ventilation Requirements During Full Load Operation		
<i>Component/Model</i>	<i>Input/Output Voltage</i>	<i>Heat Rejection BTU/hr × 1000/hr (kg–cal/hr)</i>
Powerware 40–80 kVA IDC without Transformer	N/A	N/A
Powerware 40–80 kVA IDC with Transformer	208/208	7.4 (1.8)
	480/208	

DESCRIPTION: PHYSICAL FEATURES AND REQUIREMENTS	
DRAWING NO: 164201690–2	SHEET: 2 of 2
REVISION: A	DATE: 050107

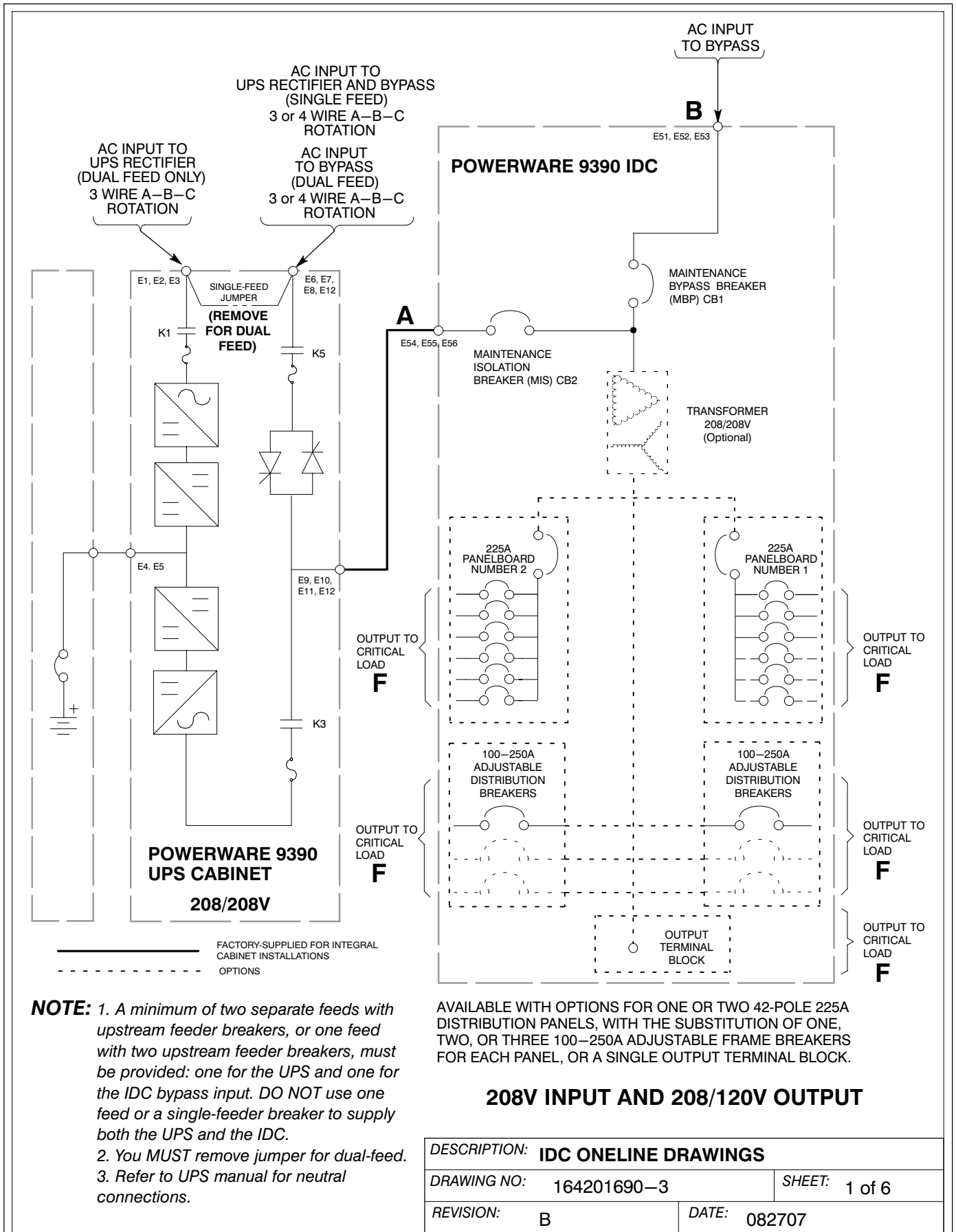

NOTE: 1. A minimum of two separate feeds with upstream feeder breakers, or one feed with two upstream feeder breakers, must be provided: one for the UPS and one for the IDC bypass input. DO NOT use one feed or a single-feeder breaker to supply both the UPS and the IDC.
 2. You MUST remove jumper for dual-feed.
 3. Refer to UPS manual for neutral connections.

AVAILABLE WITH OPTIONS FOR ONE OR TWO 42-POLE 225A DISTRIBUTION PANELS, WITH THE SUBSTITUTION OF ONE, TWO, OR THREE 100-250A ADJUSTABLE FRAME BREAKERS FOR EACH PANEL, OR A SINGLE OUTPUT TERMINAL BLOCK.

208V INPUT AND 208/120V OUTPUT

DESCRIPTION: IDC ONELINE DRAWINGS		
DRAWING NO:	164201690-3	SHEET: 1 of 6
REVISION:	B	DATE: 082707

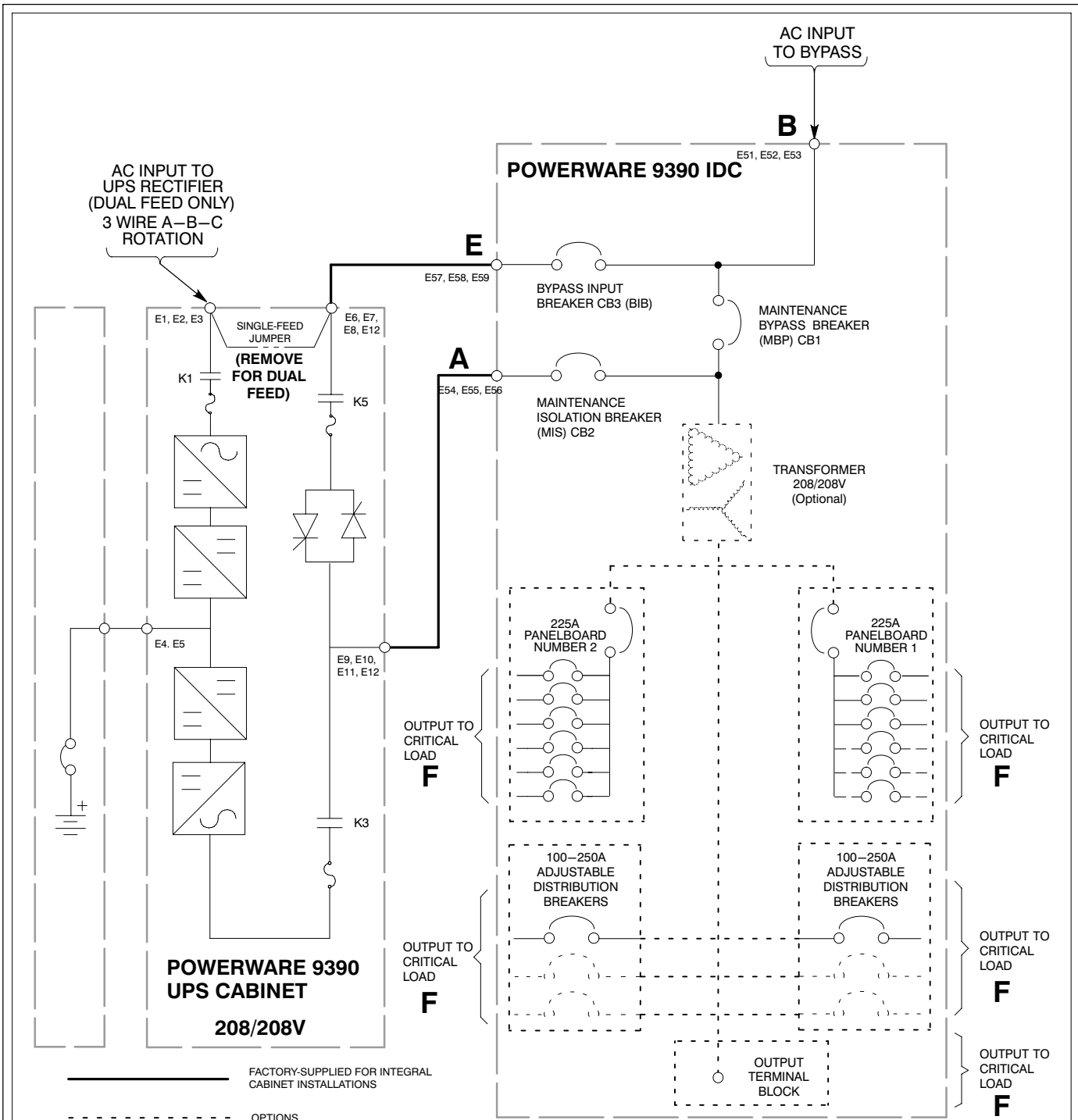

NOTE: 1. A minimum of two separate feeds with upstream feeder breakers, or one feed with two upstream feeder breakers, must be provided: one for the UPS and one for the IDC bypass input. **DO NOT** use one feed or a single-feeder breaker to supply both the UPS and the IDC.
 2. You **MUST** remove jumper for dual-feed.
 3. Refer to UPS manual for neutral connections.

AVAILABLE WITH OPTIONS FOR ONE OR TWO 42-POLE 225A DISTRIBUTION PANELS, WITH THE SUBSTITUTION OF ONE, TWO, OR THREE 100–250A ADJUSTABLE FRAME BREAKERS FOR EACH PANEL, OR A SINGLE OUTPUT TERMINAL BLOCK.

208V INPUT — 208/120V OUTPUT WITH BIB

DESCRIPTION: IDC ONELINE DRAWINGS		
DRAWING NO:	164201690–3	SHEET: 2 of 6
REVISION:	B	DATE: 082707

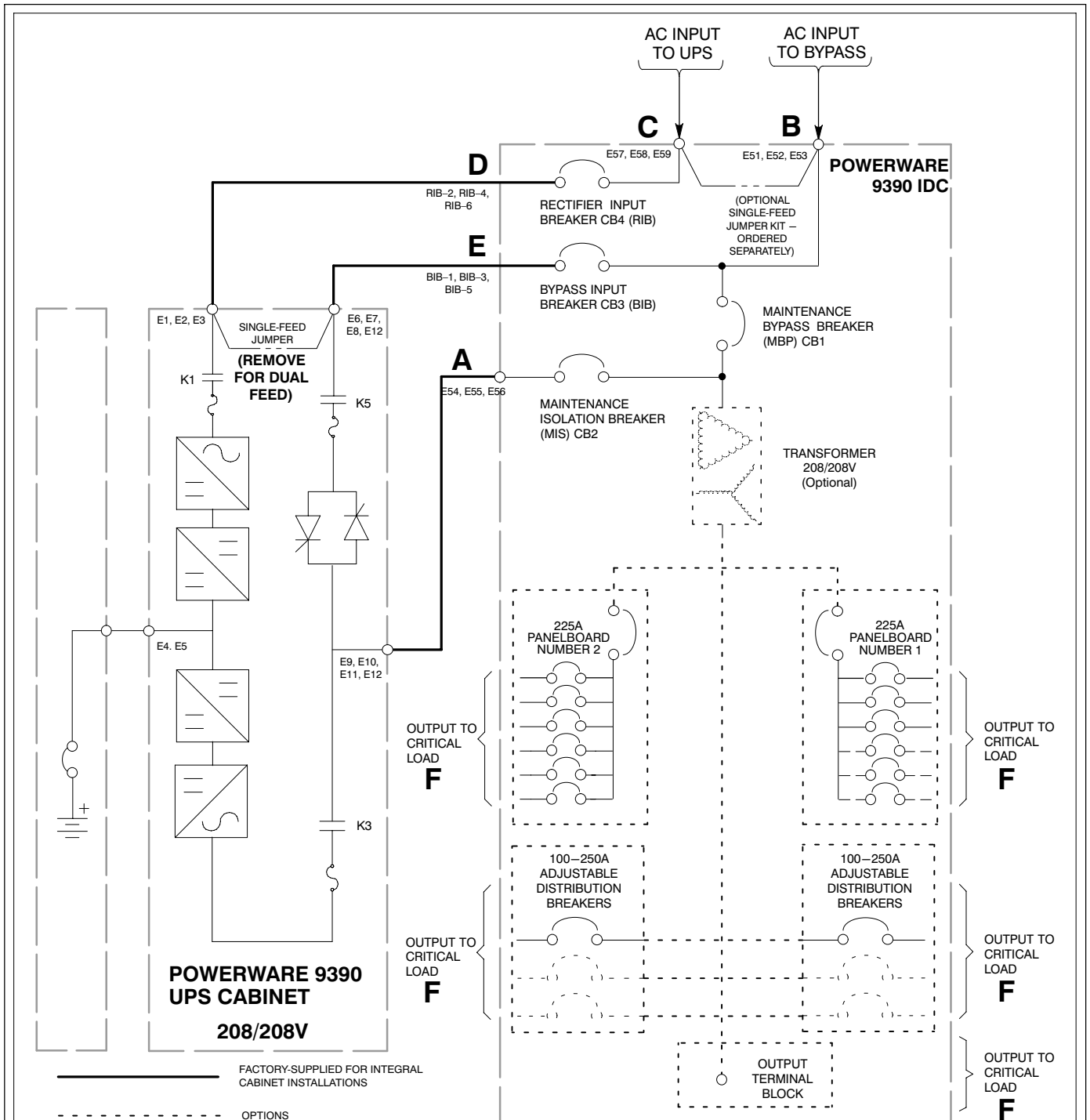

AVAILABLE WITH OPTIONS FOR ONE OR TWO 42-POLE 225A DISTRIBUTION PANELS, WITH THE SUBSTITUTION OF ONE, TWO, OR THREE 100-250A ADJUSTABLE FRAME BREAKERS FOR EACH PANEL, OR A SINGLE OUTPUT TERMINAL BLOCK.

208V INPUT — 208/120V OUTPUT WITH BIB AND RIB

NOTE: 1. You *MUST* remove jumper for dual-feed.
 2. If the load requires a neutral, a bypass neutral feeder must be supplied.

DESCRIPTION: IDC ONELINE DRAWINGS	
DRAWING NO: 164201690-3	SHEET: 3 of 6
REVISION: B	DATE: 082707

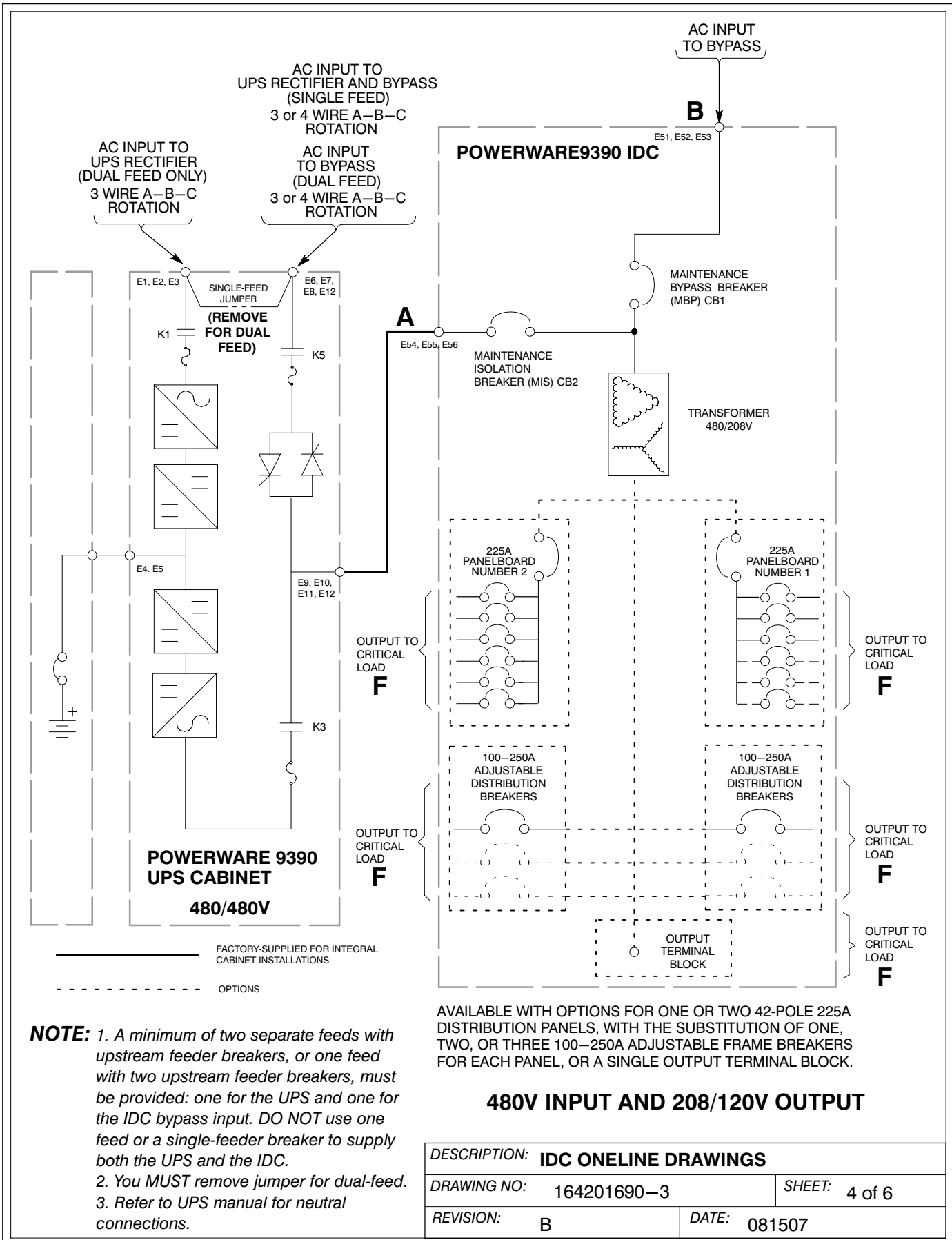

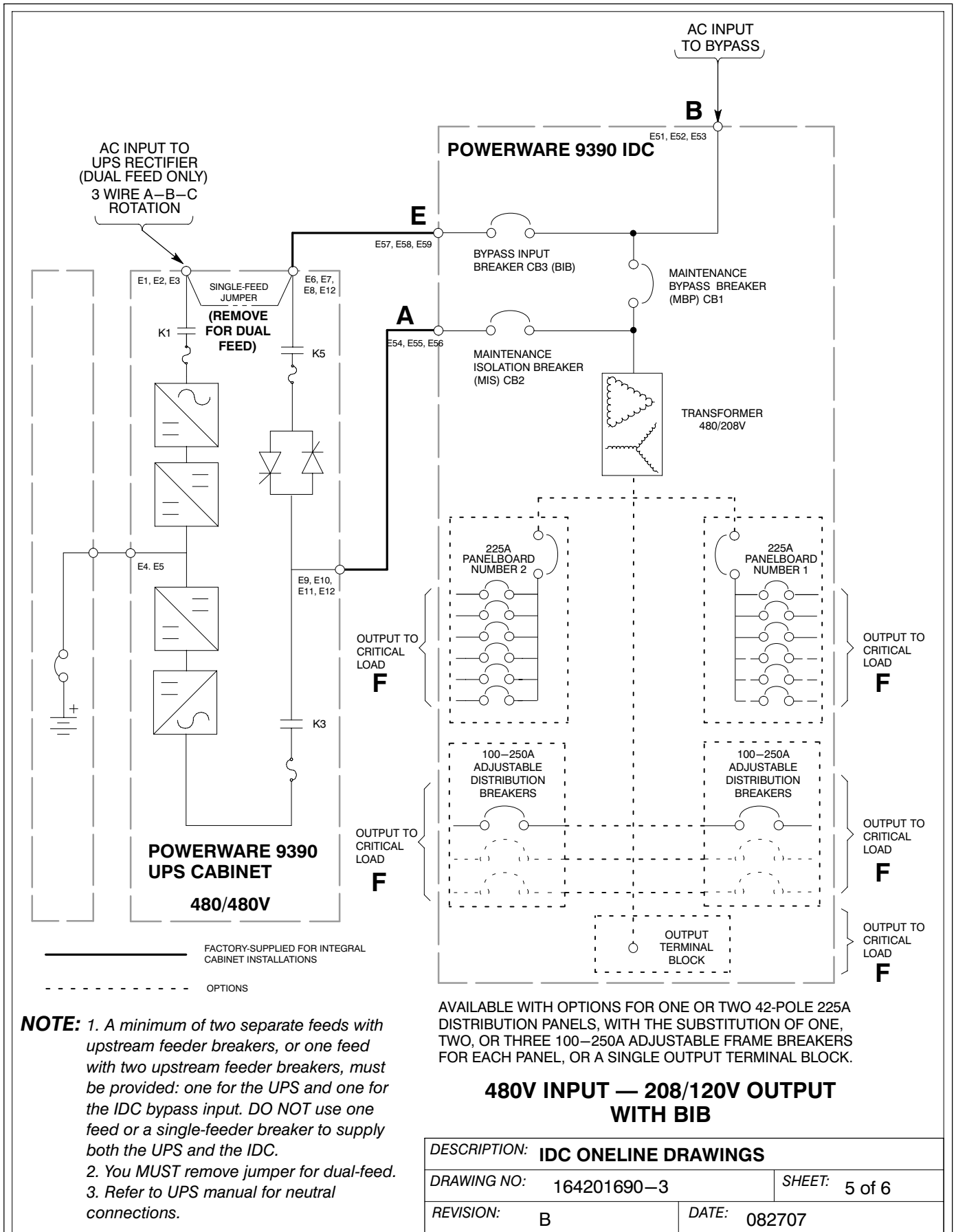

NOTE: 1. A minimum of two separate feeds with upstream feeder breakers, or one feed with two upstream feeder breakers, must be provided: one for the UPS and one for the IDC bypass input. **DO NOT** use one feed or a single-feeder breaker to supply both the UPS and the IDC.
 2. You **MUST** remove jumper for dual-feed.
 3. Refer to UPS manual for neutral connections.

AVAILABLE WITH OPTIONS FOR ONE OR TWO 42-POLE 225A DISTRIBUTION PANELS, WITH THE SUBSTITUTION OF ONE, TWO, OR THREE 100–250A ADJUSTABLE FRAME BREAKERS FOR EACH PANEL, OR A SINGLE OUTPUT TERMINAL BLOCK.

480V INPUT — 208/120V OUTPUT WITH BIB

DESCRIPTION: IDC ONELINE DRAWINGS		
DRAWING NO:	164201690–3	SHEET: 5 of 6
REVISION:	B	DATE: 082707

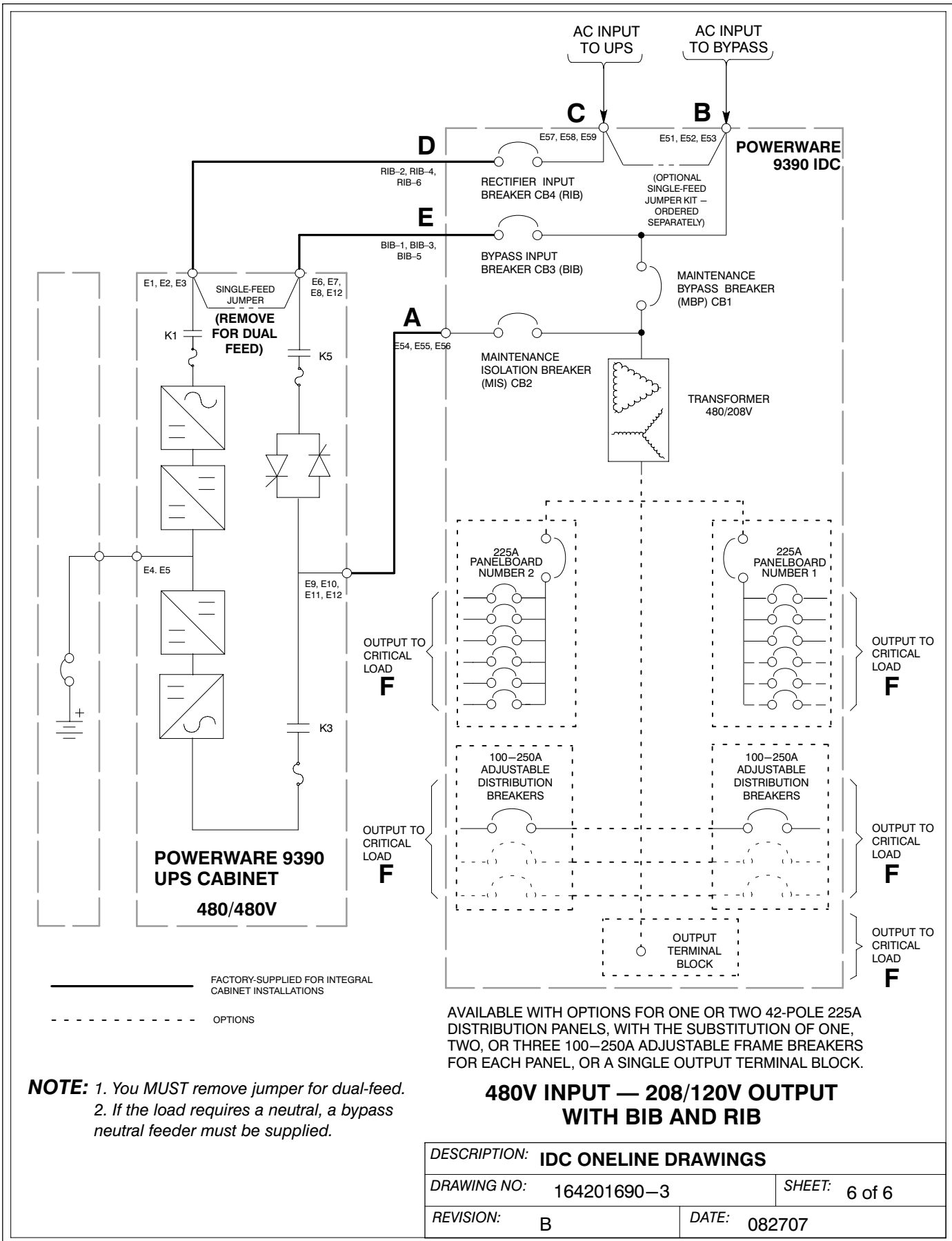

AVAILABLE WITH OPTIONS FOR ONE OR TWO 42-POLE 225A DISTRIBUTION PANELS, WITH THE SUBSTITUTION OF ONE, TWO, OR THREE 100-250A ADJUSTABLE FRAME BREAKERS FOR EACH PANEL, OR A SINGLE OUTPUT TERMINAL BLOCK.

480V INPUT — 208/120V OUTPUT WITH BIB AND RIB

DESCRIPTION: IDC ONLINE DRAWINGS	
DRAWING NO: 164201690-3	SHEET: 6 of 6
REVISION: B	DATE: 082707

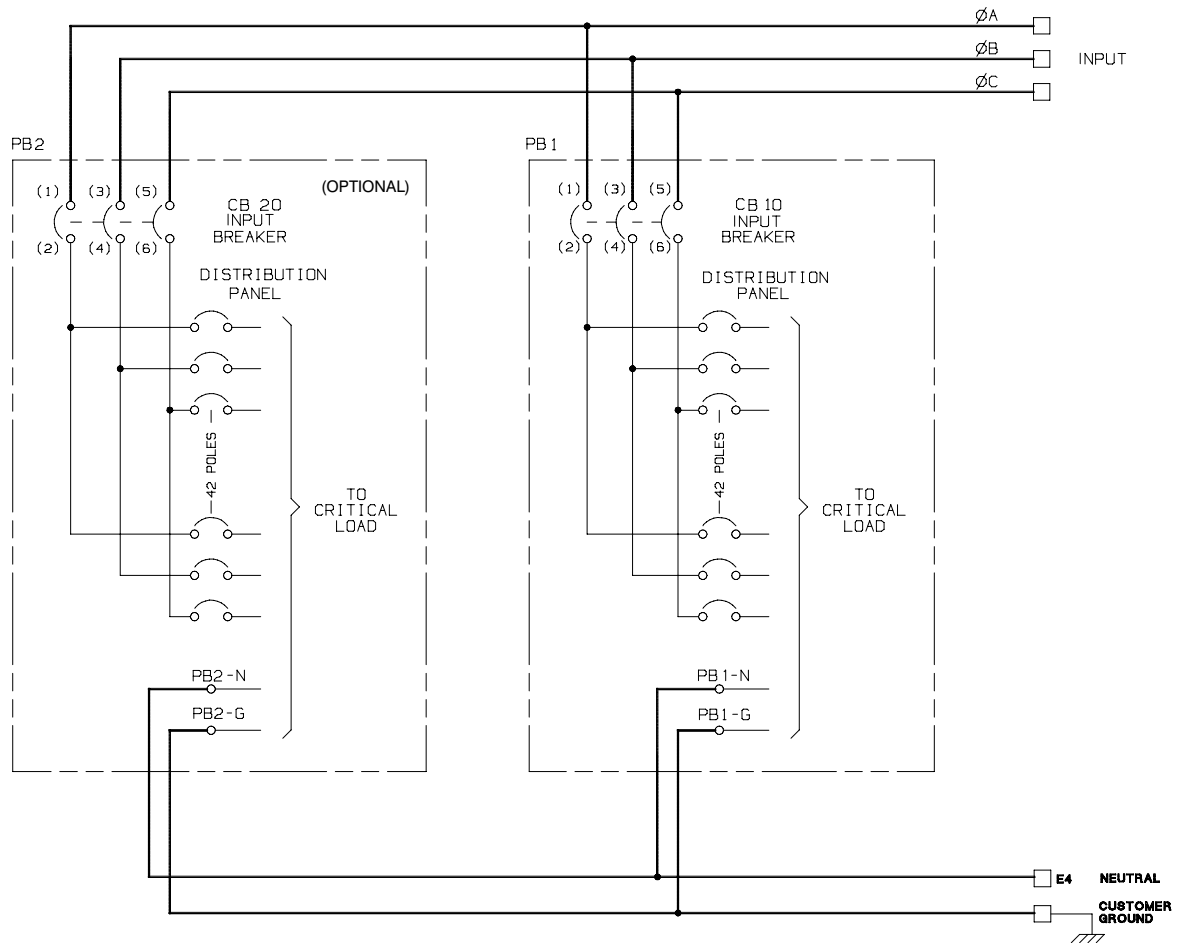

NOTE: Branch circuit breakers for PB1 and PB2 provided by customer.

DESCRIPTION: IDC DISTRIBUTION PANEL SCHEMATIC	
DRAWING NO: 164201690-4	SHEET: 1 of 1
REVISION: A	DATE: 050107

Table D. INPUT/OUTPUT Ratings & External Wiring Requirements for Powerware 9390 40 kVA IDC

		Units	Rating 60 Hz	
Basic Unit Rating		UPS kVA	20/30/40	20/30/40
IDC Input and IDC Bypass Input		VOLTS	208	480
IDC Output		VOLTS	208	208
AC Input from UPS (Standalone Installation) (3) Phases, (1) Neutral—if required, (1) Ground Minimum Conductor Size Number per Phase	A	AMPS	56/83/111	24/36/48
		AWG or kcmil (each)	For contractor-supplied wiring, refer to the <i>Powerware 9390 UPS (40–80 kVA) Installation and Operation Manual</i> for wire size. Wiring for line-up-and-match cabinet installation is factory-supplied.	
AC Input to Maintenance Bypass (Standalone Installation) (3) Phases, (1) Neutral—if required, (1) Ground Minimum Conductor Size Number per Phase	B	AMPS	56/83/111	24/36/48
		AWG or kcmil (each)	2/0 (1)	4 (1)
AC Input to Optional BIB (Standalone Installation) (3) Phases, (1) Neutral—if required, (1) Ground Minimum Conductor Size Number per Phase	C	AMPS	60/90/125	30/40/55
		AWG or kcmil (each)	2/0 (1)	4 (1)
AC Input from Optional BIB to UPS (Standalone Installation) (3) Phases, (1) Neutral—if required, (1) Ground Minimum Conductor Size Number per Phase	D	AMPS	60/90/125	30/40/55
		AWG or kcmil (each)	For contractor-supplied wiring, refer to the <i>Powerware 9390 UPS (40–80 kVA) Installation and Operation Manual</i> for wire size. Wiring for line-up-and-match cabinet installation is factory-supplied.	
AC Input from Optional RIB to UPS (Standalone Installation) (3) Phases, (1) Neutral—if required, (1) Ground Minimum Conductor Size Number per Phase	E	AMPS	60/90/125	30/40/55
		AWG or kcmil (each)	For contractor-supplied wiring, refer to the <i>Powerware 9390 UPS (40–80 kVA) Installation and Operation Manual</i> for wire size. Wiring for line-up-and-match cabinet installation is factory-supplied.	
AC Output from 225A Distribution Breaker to Critical Load (3) Phases, (1) Neutral, (1) Ground	F	Wire branch circuits according to the branch circuit breaker manufacturer's ratings, and national and local electrical codes.		
AC Output from Output Terminal Block to Critical Load (3) Phases, (1) Neutral, (1) Ground	F	Wire output according to national and local electrical codes. Refer to the <i>Powerware 9390 UPS (40–80 kVA) Installation and Operation Manual</i> for output current rating and wire size.		
AC Output from Distribution Panel Breakers to Critical Load	F	Wire branch circuits according to the branch circuit breaker manufacturer's ratings and instructions, and national and local electrical codes (output is prewired to the panelboard).		

NOTE: Callout letters **A, B, C, D, E** and **F** map to drawing 164201690–3.

DESCRIPTION: POWER WIRING INSTALLATION NOTES	
DRAWING NO: 164201690–5	SHEET: 1 of 7
REVISION: B	DATE: 082707

Table E. INPUT/OUTPUT Ratings & External Wiring Requirements for Powerware 9390 80 kVA IDC				
		Units	Rating 60 Hz	
Basic Unit Rating		UPS kVA	40/50/60/80	40/50/60/80
IDC Input and IDC Bypass Input		VOLTS	208	480
IDC Output		VOLTS	208	208
AC Input from UPS (Standalone Installation) (3) Phases, (1) Neutral—if required, (1) Ground Minimum Conductor Size Number per Phase	A	AMPS	111/139/167/222	48/60/72/96
		AWG or kcmil (each)	For contractor-supplied wiring, refer to the <i>Powerware 9390 UPS (40–80 kVA) Installation and Operation Manual</i> for wire size. Wiring for line-up-and-match cabinet installation is factory-supplied.	
AC Input to Maintenance Bypass (Standalone Installation) (3) Phases, (1) Neutral—if required, (1) Ground Minimum Conductor Size Number per Phase	B	AMPS	111/139/167/222	48/60/72/96
		AWG or kcmil (each)	2/0 (2)	1/0 (1)
AC Input to Optional BIB (Standalone Installation) (3) Phases, (1) Neutral—if required, (1) Ground Minimum Conductor Size Number per Phase	C	AMPS	125/155/185/240	55/67/80/105
		AWG or kcmil (each)	2/0 (2)	1/0 (1)
AC Input from Optional BIB to UPS (Standalone Installation) (3) Phases, (1) Neutral—if required, (1) Ground Minimum Conductor Size Number per Phase	D	AMPS	125/155/185/240	55/67/80/105
		AWG or kcmil (each)	For contractor-supplied wiring, refer to the <i>Powerware 9390 UPS (40–80 kVA) Installation and Operation Manual</i> for wire size. Wiring for line-up-and-match cabinet installation is factory-supplied.	
AC Input from Optional RIB to UPS (Standalone Installation) (3) Phases, (1) Neutral—if required, (1) Ground Minimum Conductor Size Number per Phase	E	AMPS	125/155/185/240	55/67/80/105
		AWG or kcmil (each)	For contractor-supplied wiring, refer to the <i>Powerware 9390 UPS (40–80 kVA) Installation and Operation Manual</i> for wire size. Wiring for line-up-and-match cabinet installation is factory-supplied.	
AC Output from 225A Distribution Breaker to Critical Load (3) Phases, (1) Neutral, (1) Ground	F	Wire branch circuits according to the branch circuit breaker manufacturer's ratings, and national and local electrical codes.		
AC Output from Output Terminal Block to Critical Load (3) Phases, (1) Neutral, (1) Ground	F	Wire output according to national and local electrical codes. Refer to the <i>Powerware 9390 UPS (40–80 kVA) Installation and Operation Manual</i> for output current rating and wire size.		
AC Output from Distribution Panel Breakers to Critical Load	F	Wire branch circuits according to the branch circuit breaker manufacturer's ratings and instructions, and national and local electrical codes (output is prewired to the panelboard).		

NOTE: Callout letters **A, B, C, D, E** and **F** map to drawing 164201690–3.

DESCRIPTION: POWER WIRING INSTALLATION NOTES	
DRAWING NO: 164201690–5	SHEET: 2 of 7
REVISION: B	DATE: 082707

Read and understand the following notes while planning and performing the installation:

1. Refer to national and local electrical codes for acceptable external wiring practices.
2. Material and labor for external wiring requirements are to be provided by designated personnel.
3. For external input wiring, use 90°C copper wire. See the appropriate column in Table D. Wire sizes are based on using the specified breakers.
4. Wire ampacities are chosen from Table 310–16 of the NEC. Input wire is 90°C specification.
5. A minimum of two separate feeds with upstream feeder breakers, or one feed with two upstream feeder breakers, must be provided. One for the UPS and one for the IDC bypass input. DO NOT use one feed or a single-feeder breaker to supply both the UPS and IDC.
6. The IDC is shipped with a debris shield covering the ventilation grill on top of the unit. Do not remove the debris shield until installation is complete. However, remove the shield before operating the IDC. Once the debris shield is removed, do not place objects on the ventilation grill.
7. The optional 225A distribution panel uses Cutler-Hammer Bolt-on Type BAB or QBHW breakers to be provided by the customer.
8. Refer to Section I of this manual for installation instructions.
9. Refer to the *Powerware 9390 UPS (40–80 kVA) Installation and Operation Manual* for UPS cabinet conduit and terminal locations.
10. Terminals are UL and CSA rated at 90°C. Refer to Table F and Table G for power cable terminations, and Table H for conduit requirements. Drawing 164201690–7 shows the location of the power cable terminals inside the UPS cabinet.
11. Per NEC article 300-20(a), all three-phase conductors must be run in the same conduit. Neutral and ground must be run in the same conduit as the phase conductors.

DESCRIPTION: POWER WIRING INSTALLATION NOTES	
DRAWING NO: 164201690–5	SHEET: 3 of 7
REVISION: B	DATE: 082707

Table F. IDC Power Cable Terminations 40 kVA 208V/208V, 80 kVA 480V/208V						
<i>Terminal Function</i>	<i>Terminal</i>	<i>Function</i>	<i>Size of Pressure Termination</i>	<i>Tightening Torque Nm (lb in)</i>	<i>Type Screw</i>	
AC Input from UPS	E54	Phase A	2 – #6–250 kcmil	42.4 (375)	5/16" Hex	
	E55	Phase B	2 – #6–250 kcmil	42.4 (375)	5/16" Hex	
	E56	Phase C	2 – #6–250 kcmil	42.4 (375)	5/16" Hex	
AC Input to Maintenance Bypass	E51	Phase A	2 – #6–250 kcmil	42.4 (375)	5/16" Hex	
	E52	Phase B	2 – #6–250 kcmil	42.4 (375)	5/16" Hex	
	E53	Phase C	2 – #6–250 kcmil	42.4 (375)	5/16" Hex	
AC Input to Optional RIB	E57	Phase A	2 – #6–250 kcmil	42.4 (375)	5/16" Hex	
	E58	Phase B	2 – #6–250 kcmil	42.4 (375)	5/16" Hex	
	E59	Phase C	2 – #6–250 kcmil	42.4 (375)	5/16" Hex	
AC Output from Optional RIB (CB4) to UPS	RIB–2	Phase A	1 – #4–350 kcmil	20.3 (180)	3/16" Hex	
	RIB–4	Phase B	1 – #4–350 kcmil	20.3 (180)	3/16" Hex	
	RIB–6	Phase C	1 – #4–350 kcmil	20.3 (180)	3/16" Hex	
AC Output from Optional BIB to UPS (without RIB)	E57	Phase A	2 – #6–250 kcmil	42.4 (375)	5/16" Hex	
	E58	Phase B	2 – #6–250 kcmil	42.4 (375)	5/16" Hex	
	E59	Phase C	2 – #6–250 kcmil	42.4 (375)	5/16" Hex	
AC Output from Optional BIB (CB3) to UPS (with RIB)	BIB–1	Phase A	1 – #4–350 kcmil	20.3 (180)	3/16" Hex	
	BIB–3	Phase B	1 – #4–350 kcmil	20.3 (180)	3/16" Hex	
	BIB–5	Phase C	1 – #4–350 kcmil	20.3 (180)	3/16" Hex	
Ground	E8, E9	Ground	2 – #14–1/0	5.6 (50)	Slotted	
AC Output from Distribution Breaker to Critical Load	CBxx–2	Phase A	1 – #4–350 kcmil	20.3 (180)	3/16" Hex	
	CBxx–4	Phase B	1 – #4–350 kcmil	20.3 (180)	3/16" Hex	
	CBxx–6	Phase C	1 – #4–350 kcmil	20.3 (180)	3/16" Hex	
Neutral Ground	E10, E20	Neutral	4 ea. – #4–300 kcmil	31 (275)	5/16" Hex	
	E18, E19, E28, E29	Ground	2 ea. – #14–1/0	5.6 (50)	Slotted	
AC Output from Output Terminal Block to Critical Load	E11	Phase A	2 – #6–500 kcmil	56.5 (500)	1/2" Hex	
	E12	Phase B	2 – #6–500 kcmil	56.5 (500)	1/2" Hex	
	E13	Phase C	2 – #6–500 kcmil	56.5 (500)	1/2" Hex	
Neutral Ground	E10	Neutral	4 – #6–500 kcmil	56.5 (500)	1/2" Hex	
	E19	Ground	2 – #14–1/0	5.6 (50)	Slotted	
AC Output from Distribution Panel Breakers to Critical Load	Wire branch circuits in accordance with branch circuit breaker manufacturers ratings and instructions (output is prewired to the panelboard)					
	Neutral	PB1–N PB2–N	Neutral	42 – #4–#14	#4–#6: 4.0 (35) #8: 2.8 (25) #10–#14: 2.3 (20)	Slotted
		Ground	E18, E19, E28, E29	Ground	42 – #4–#14	#4–#6: 4.0 (35) #8: 2.8 (25) #10–#14: 2.3 (20)

DESCRIPTION: POWER WIRING INSTALLATION NOTES	
DRAWING NO: 164201690–5	SHEET: 4 of 7
REVISION: B	DATE: 082707

Table G. IDC Power Cable Terminations 80 kVA 208V/208V						
<i>Terminal Function</i>	<i>Terminal</i>	<i>Function</i>	<i>Size of Pressure Termination</i>	<i>Tightening Torque Nm (lb in)</i>	<i>Type Screw</i>	
AC Input from UPS	E54	Phase A	2 – #6–250 kcmil	42.4 (375)	5/16" Hex	
	E55	Phase B	2 – #6–250 kcmil	42.4 (375)	5/16" Hex	
	E56	Phase C	2 – #6–250 kcmil	42.4 (375)	5/16" Hex	
AC Input to Maintenance Bypass	E51	Phase A	2 – #6–250 kcmil	42.4 (375)	5/16" Hex	
	E52	Phase B	2 – #6–250 kcmil	42.4 (375)	5/16" Hex	
	E53	Phase C	2 – #6–250 kcmil	42.4 (375)	5/16" Hex	
AC Input to Optional RIB	E57	Phase A	2 – #6–250 kcmil	42.4 (375)	5/16" Hex	
	E58	Phase B	2 – #6–250 kcmil	42.4 (375)	5/16" Hex	
	E59	Phase C	2 – #6–250 kcmil	42.4 (375)	5/16" Hex	
AC Output from Optional RIB (CB4) to UPS	RIB–2	Phase A	1 – 2/0–250 kcmil	31.1 (275)	5/16" Hex	
			1 – 2/0–500 kcmil	31.1 (275)	3/8" Hex	
	RIB–4	Phase B	1 – 2/0–250 kcmil	31.1 (275)	5/16" Hex	
			1 – 2/0–500 kcmil	31.1 (275)	3/8" Hex	
	RIB–6	Phase C	1 – 2/0–250 kcmil	31.1 (275)	5/16" Hex	
			1 – 2/0–500 kcmil	31.1 (275)	3/8" Hex	
	E57	Phase A	2 – #6–250 kcmil	42.4 (375)	5/16" Hex	
AC Output from Optional BIB to UPS (without RIB)	E58	Phase B	2 – #6–250 kcmil	42.4 (375)	5/16" Hex	
	E59	Phase C	2 – #6–250 kcmil	42.4 (375)	5/16" Hex	
	AC Output from Optional BIB (CB3) to UPS (with RIB)	BIB–1	Phase A	1 – 2/0–250 kcmil	31.1 (275)	5/16" Hex
1 – 2/0–500 kcmil				31.1 (275)	3/8" Hex	
BIB–3		Phase B	1 – 2/0–250 kcmil	31.1 (275)	5/16" Hex	
			1 – 2/0–500 kcmil	31.1 (275)	3/8" Hex	
	BIB–5	Phase C	1 – 2/0–250 kcmil	31.1 (275)	5/16" Hex	
			1 – 2/0–500 kcmil	31.1 (275)	3/8" Hex	
	E8, E9	Ground	2 – #14–1/0	5.6 (50)	Slotted	
AC Output from Distribution Breaker to Critical Load	CBxx–2	Phase A	1 – #4–350 kcmil	20.3 (180)	3/16" Hex	
	CBxx–4	Phase B	1 – #4–350 kcmil	20.3 (180)	3/16" Hex	
	CBxx–6	Phase C	1 – #4–350 kcmil	20.3 (180)	3/16" Hex	
Neutral	E10, E20	Neutral	4 ea. – #4–300 kcmil	31 (275)	5/16 Hex	
Ground	E18, E19, E28, E29	Ground	2 ea. – #14–1/0	5.6 (50)	Slotted	
AC Output from Output Terminal Block to Critical Load	E11	Phase A	2 – #6–500 kcmil	56.5 (500)	1/2" Hex	
	E12	Phase B	2 – #6–500 kcmil	56.5 (500)	1/2" Hex	
	E13	Phase C	2 – #6–500 kcmil	56.5 (500)	1/2" Hex	
Neutral	E10	Neutral	4 – #6–500 kcmil	56.5 (500)	1/2" Hex	
Ground	E19	Ground	2 – #14–1/0	5.6 (50)	Slotted	
AC Output from Distribution Panel Breakers to Critical Load	Wire branch circuits in accordance with branch circuit breaker manufacturers ratings and instructions (output is prewired to the panelboard)					
	Neutral	PB1–N PB2–N	Neutral	42 – #4–#14	#4–#6: 4.0 (35) #8: 2.8 (25) #10–#14: 2.3 (20)	Slotted
		Ground	E18, E19, E28, E29	Ground	42 – #4–#14	#4–#6: 4.0 (35) #8: 2.8 (25) #10–#14: 2.3 (20)

DESCRIPTION: POWER WIRING INSTALLATION NOTES	
DRAWING NO: 164201690–5	SHEET: 5 of 7
REVISION: A	DATE: 050107

- 12.** Conduit is sized to accommodate one neutral conductor the same size as the phase conductor and one #8 AWG ground conductor. If two neutral conductors or an oversized neutral conductor are to be installed, check the size of the conduit needed to accommodate the extra wire or size and use that conduit size in place of the conduit size listed in Table H. All Powerware 9390 products can accommodate a double-size neutral.
- 13.** Conduit sizes were based on THHN wire and flexible, metal conduit from NEC Table C3.

Table H. Power Cable Conduit Requirements					
<i>UPS Model</i>	<i>Voltage</i>	<i>Terminal</i>	<i>Number of Wires in Conduit</i>	<i>Minimum Conduit Trade Size (inches)</i>	<i>Number of Conduits</i>
9390–80	208 Input without Transformer	AC Input to IDC from UPS (A, B, C, N, Gnd)	6	2	2
		AC Input to IDC Bypass (A, B, C, N, Gnd)	6	2	2
9390–80	208 Input with Transformer	AC Input to IDC from UPS (A, B, C, Gnd)	7	2-1/2	1
		AC Input to IDC Bypass (A, B, C, Gnd)	7	2-1/2	1
9390–80	480 Input with Transformer	AC Input to IDC from UPS (A, B, C, Gnd)	4	1-1/2	1
		AC Input to IDC Bypass (A, B, C, Gnd)	4	1-1/2	1
All Models	208/120 Output	Distribution Panel Output (user defined)	3 minimum (user defined)	(32) 1/2 (13) 1/2–3/4 knockouts	1 per breaker
All Models	208 Output	Distribution Output Breaker (A, B, C, N, Gnd)	6	3	1 per breaker
All Models	208 Output	Output Terminal Block (A, B, C, N, Gnd)	6	2	2

<i>DESCRIPTION:</i> POWER WIRING INSTALLATION NOTES	
<i>DRAWING NO:</i> 164201690–5	<i>SHEET:</i> 6 of 7
<i>REVISION:</i> A	<i>DATE:</i> 050107

- 14. External bypass input overcurrent protection is not provided by this product, but is required by codes. Refer to Table D for wiring requirements.
- 15. Table I lists the maximum rating for bypass input circuit breakers.

Table I. Maximum Bypass Input Circuit Breaker Ratings			
<i>IDC Model</i>	<i>Input Voltage Rating</i>		
		208V	480V
IDC 40–80 kVA	80% Rated	350A	150A
	100% Rated	300A	125A

CAUTION



To reduce the risk of fire, connect only to a circuit provided with maximum input circuit breaker current ratings from Table I according to the National Electrical Code, ANSI/NFPA 70.

- 16. If the installed IDC contains a transformer, source protection for the AC input should be treated as if you were supplying an 80 kVA three phase transformer, to allow for inrush current. Maintenance bypass input wiring and maintenance bypass input breaker rating should be treated as if supplying a 80 kVA load, regardless of the rating of the UPS.

<i>DESCRIPTION:</i> POWER WIRING INSTALLATION NOTES	
<i>DRAWING NO:</i> 164201690–5	<i>SHEET:</i> 7 of 7
<i>REVISION:</i> A	<i>DATE:</i> 050107

REMOVE DEBRIS SHIELD COVERING THE VENTILATION GRILL BEFORE OPERATING SYSTEM.

TOP VIEW

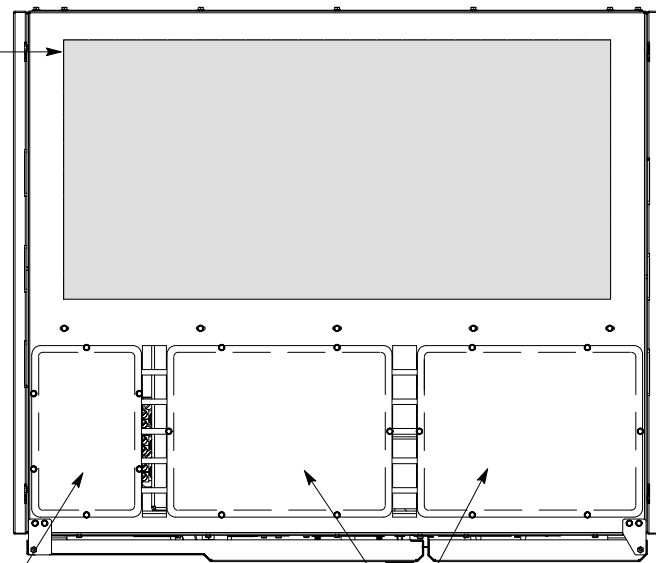

TOP ENTRY CONDUIT LANDING PLATE FOR AC INPUT AND INTERFACE CONNECTIONS. (REMOVE PANEL TO DRILL OR PUNCH CONDUIT HOLES.)

TOP ENTRY CONDUIT LANDING PLATE FOR AC OUTPUT. (REMOVE PANEL TO DRILL OR PUNCH CONDUIT HOLES.)

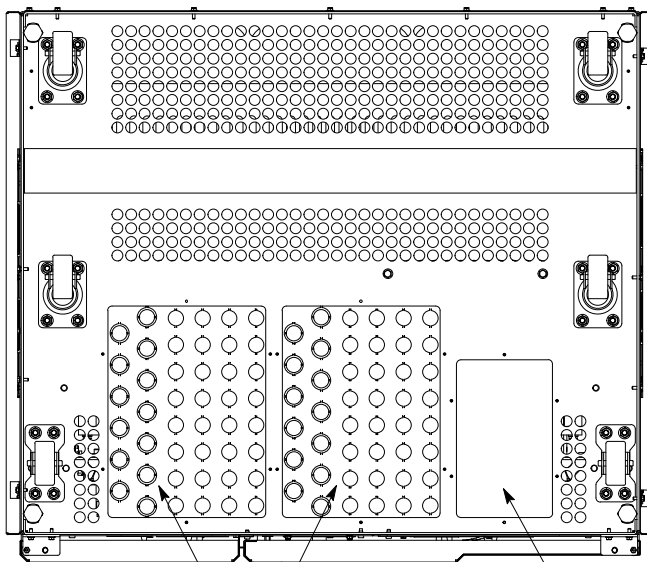

BOTTOM ENTRY CONDUIT LANDING PLATE FOR AC OUTPUT. (REMOVE PANEL TO REMOVE KNOCKOUTS.)

BOTTOM ENTRY CONDUIT LANDING PLATE FOR AC INPUT AND INTERFACE CONNECTIONS. (REMOVE PANEL TO DRILL OR PUNCH CONDUIT HOLES.)

BOTTOM VIEW

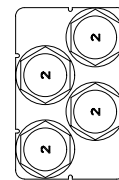
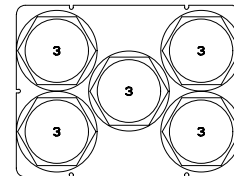

MAXIMUM CONDUIT LANDING PUNCH PATTERNS (TOP ENTRY SHOWN). BOTTOM ENTRY OUTPUT PLATES ARE PRE-PUNCHED FOR DISTRIBUTION PANELS AND MAY BE INTERCHANGED WITH TOP OUTPUT PLATES.

DESCRIPTION: CONDUIT AND WIRE ENTRY LOCATIONS		
DRAWING NO: 164201690-6	SHEET: 1 of 2	
REVISION: A	DATE: 050107	

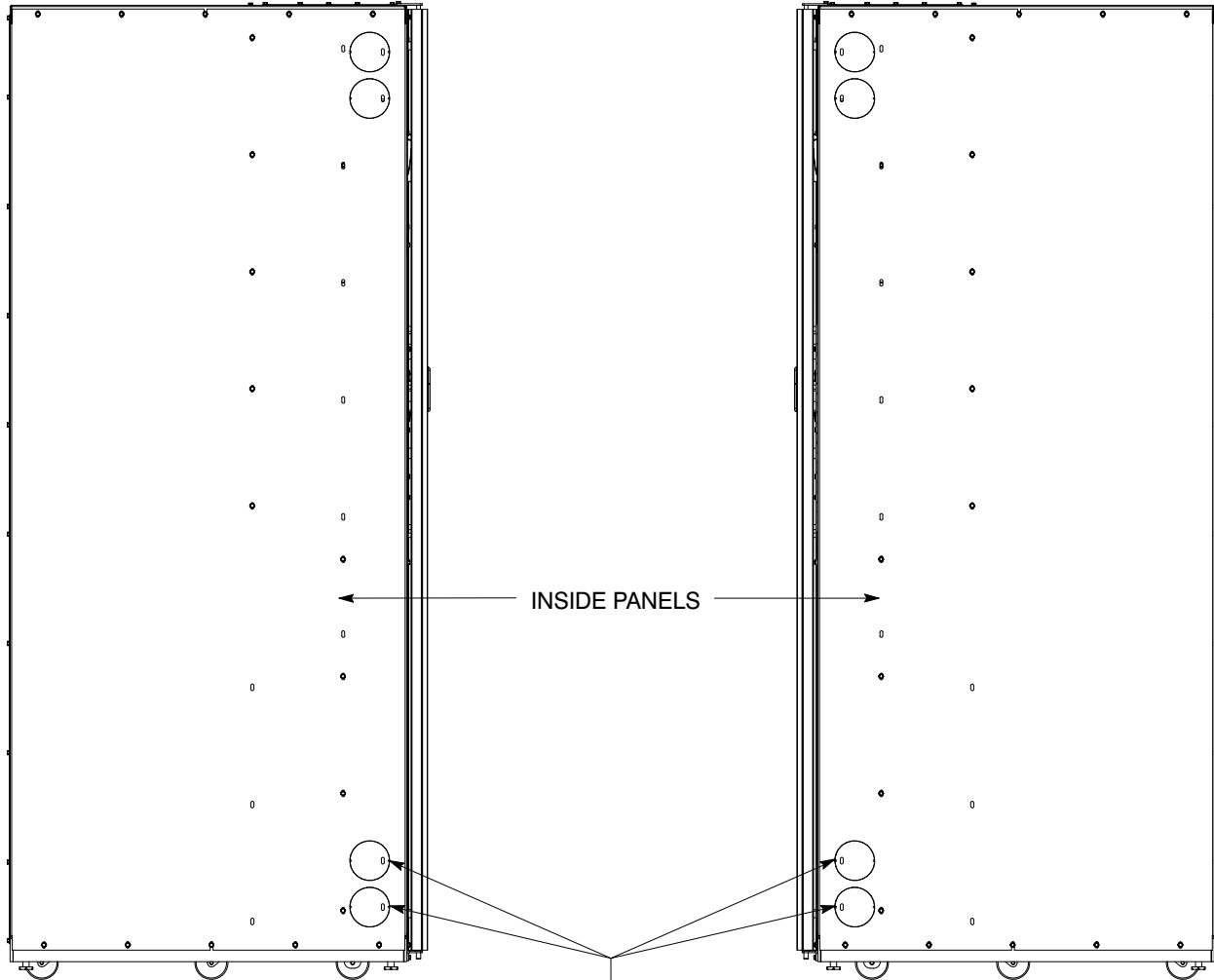

LEFT SIDE VIEW

RIGHT SIDE VIEW

INTER-CABINET WIRING ACCESS KNOCKOUTS. REMOVE KNOCKOUTS, AS REQUIRED, TO ROUTE WIRES BETWEEN CABINETS. INSTALL NYLON GROMMETS AFTER REMOVAL OF KNOCKOUTS.

<i>DESCRIPTION:</i> CONDUIT AND WIRE ENTRY LOCATIONS	
<i>DRAWING NO:</i> 164201690-6	<i>SHEET:</i> 2 of 2
<i>REVISION:</i> A	<i>DATE:</i> 050107

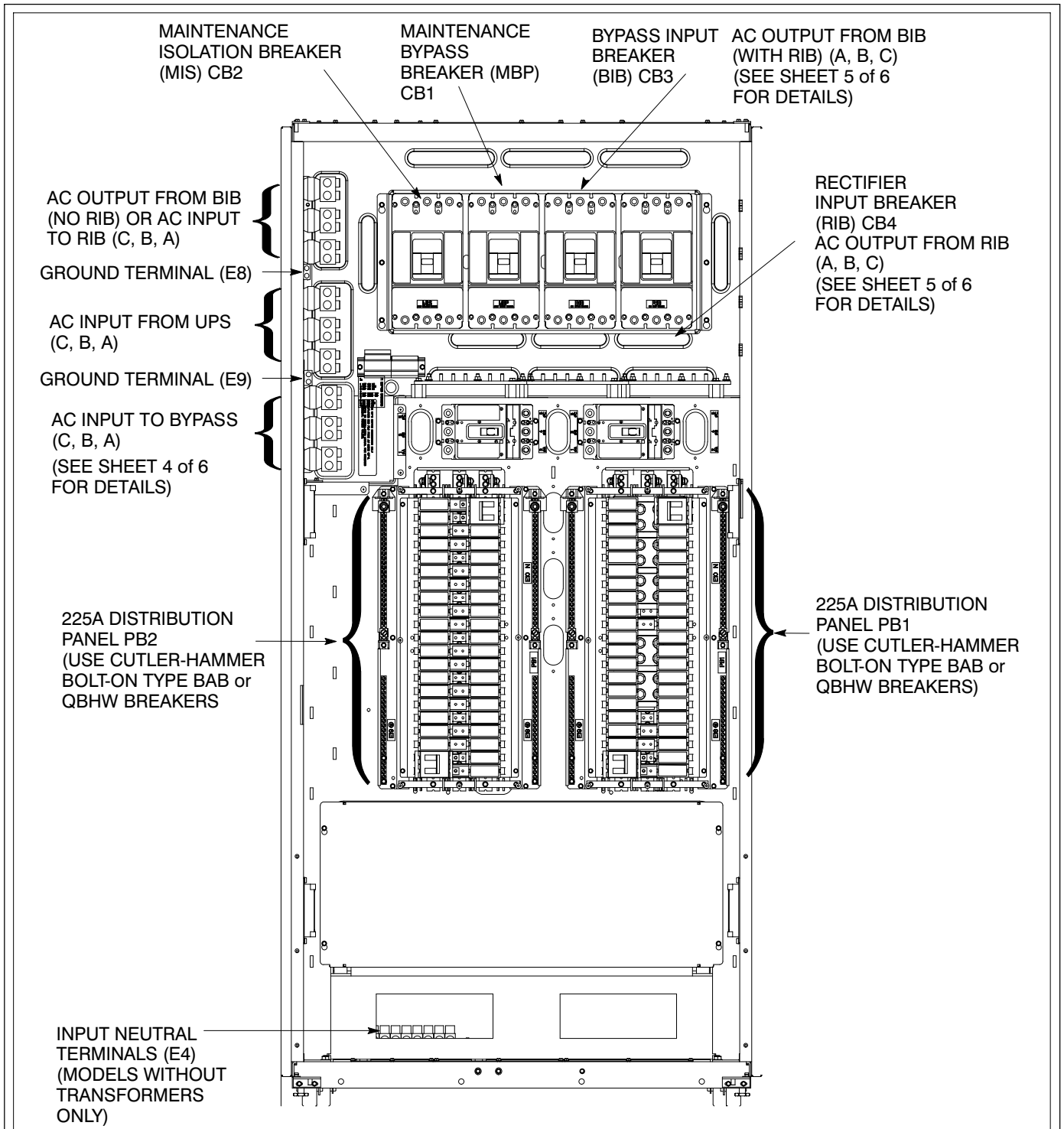

80 kVA 208V/120V INPUT with OUTPUT DISTRIBUTION PANEL OPTION 208V INPUT WITH OR WITHOUT TRANSFORMER OPTION

NOTE: Metal shields covering wiring terminals must be removed or opened to gain access to terminals.

DESCRIPTION: IDC POWER TERMINAL LOCATIONS (208V)	
DRAWING NO: 164201690-7	SHEET: 1 of 6
REVISION: B	DATE: 082707

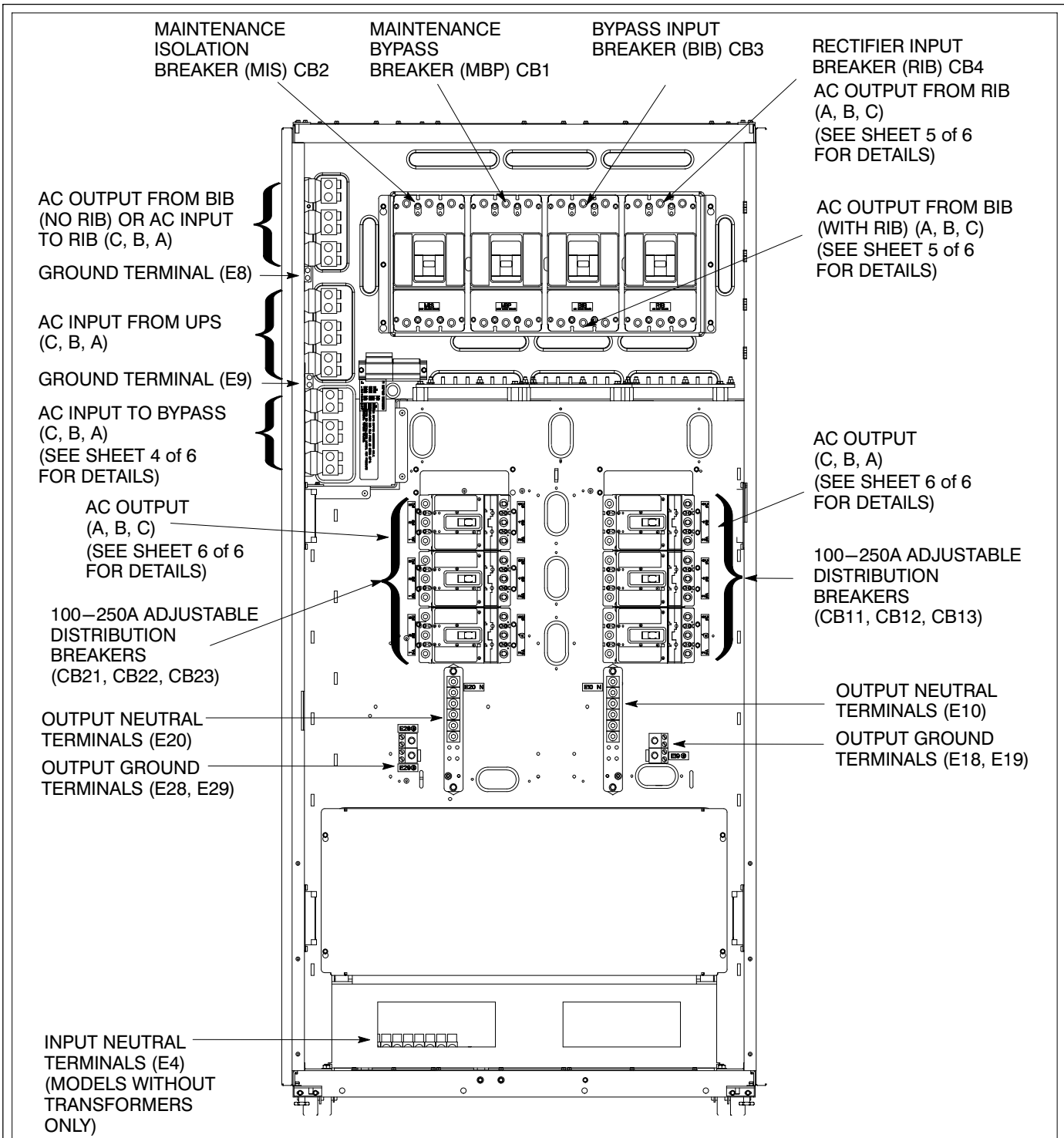

80 kVA 208V INPUT with OUTPUT DISTRIBUTION BREAKER OPTION
 208V INPUT WITH OR WITHOUT TRANSFORMER OPTION

NOTE: Metal shields covering wiring terminals must be removed or opened to gain access to terminals.

DESCRIPTION: IDC POWER TERMINAL LOCATIONS (208V)	
DRAWING NO: 164201690-7	SHEET: 2 of 6
REVISION: A	DATE: 050107

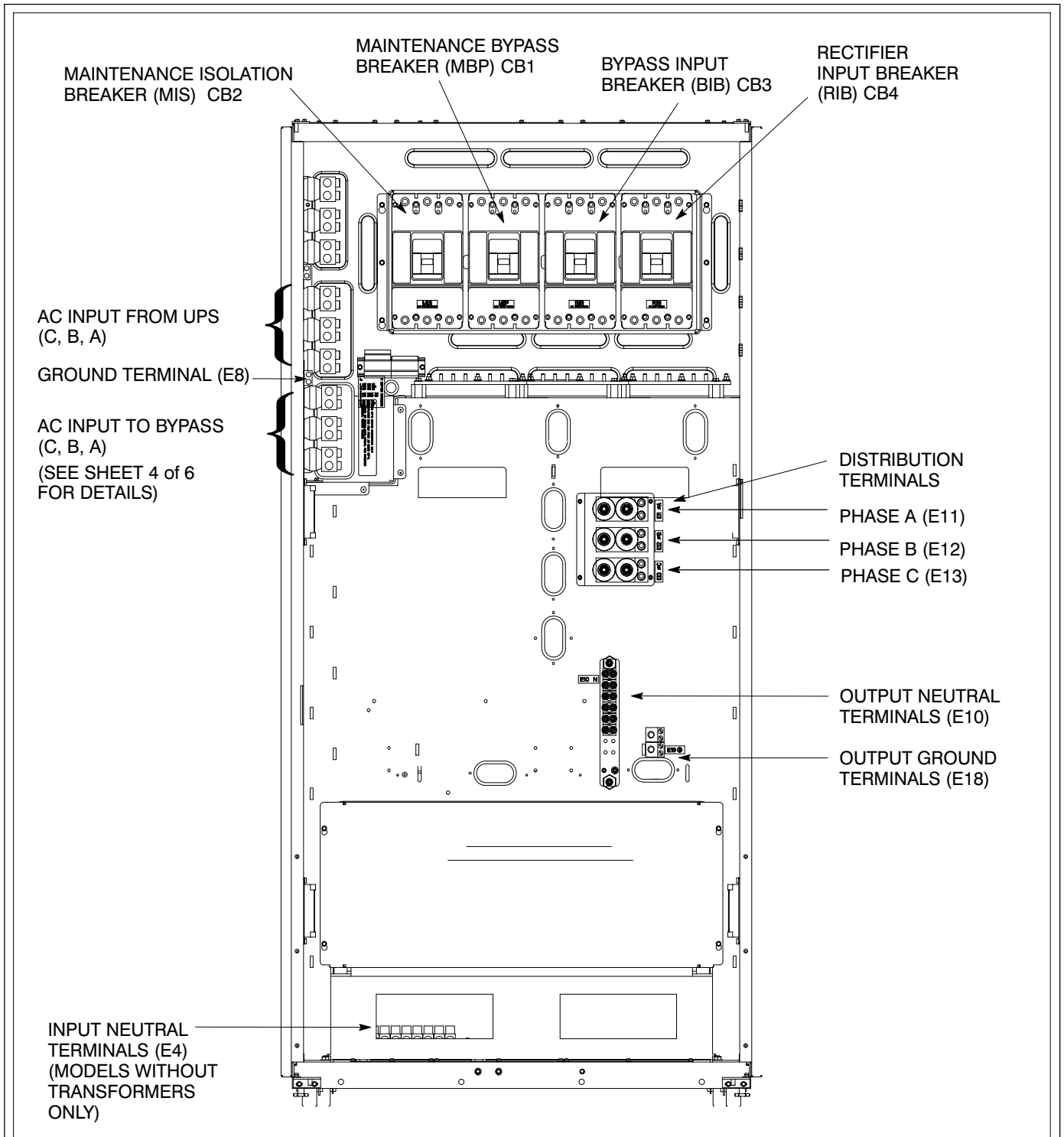

80 kVA 208V INPUT with OUTPUT TERMINAL BLOCK OPTION
 208V INPUT WITH OR WITHOUT TRANSFORMER OPTION

NOTE: Metal shields covering wiring terminals must be removed or opened to gain access to terminals.

DESCRIPTION: IDC POWER TERMINAL LOCATIONS (208V)		
DRAWING NO:	164201690-7	SHEET: 3 of 6
REVISION:	B	DATE: 082707

MAINTENANCE BYPASS INPUT TERMINAL DETAIL

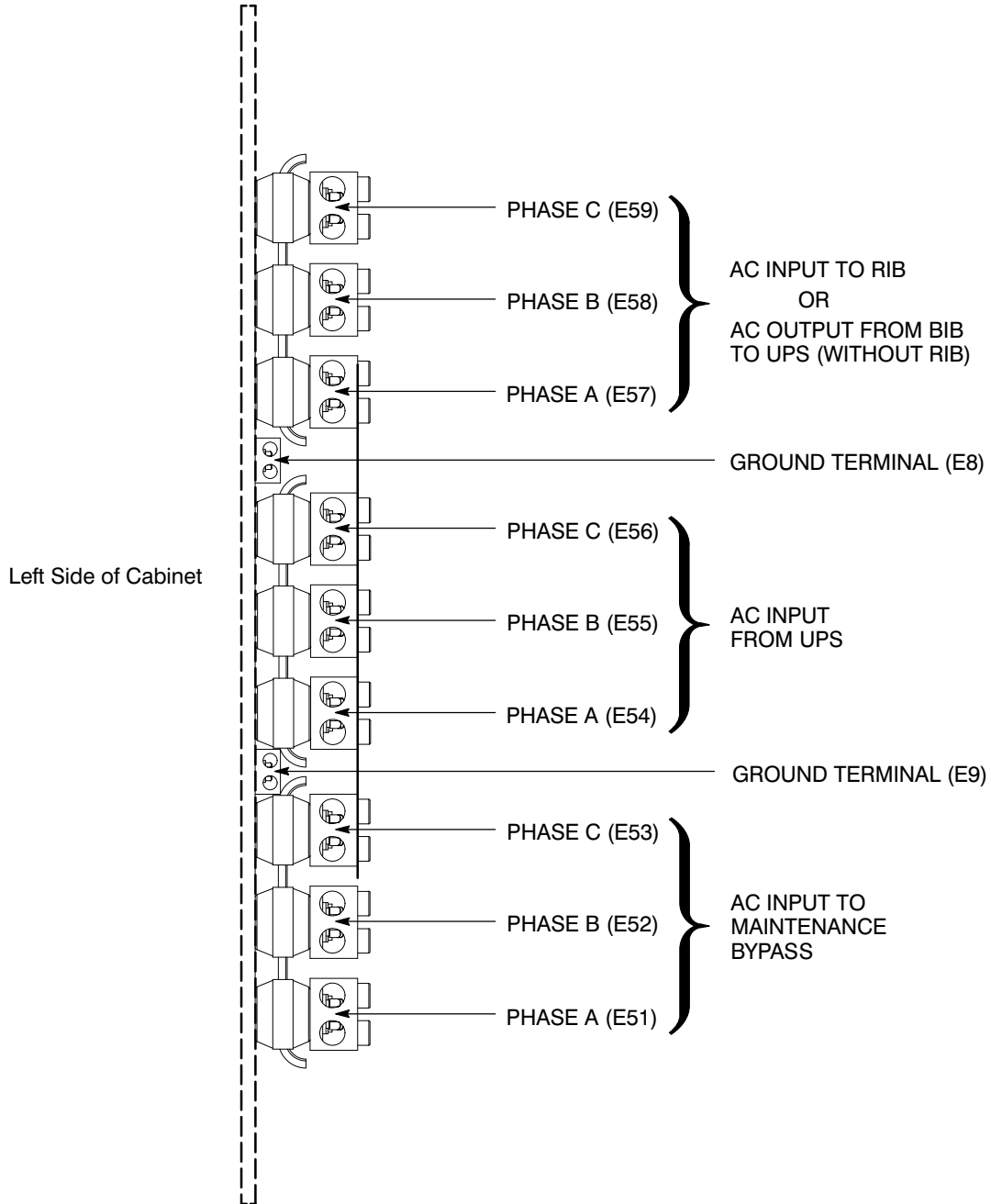

DESCRIPTION: **IDC POWER TERMINAL LOCATIONS (208V)**

DRAWING NO: 164201690-7

SHEET: 4 of 6

REVISION: A

DATE: 050107

BIB AND RIB TERMINAL DETAIL

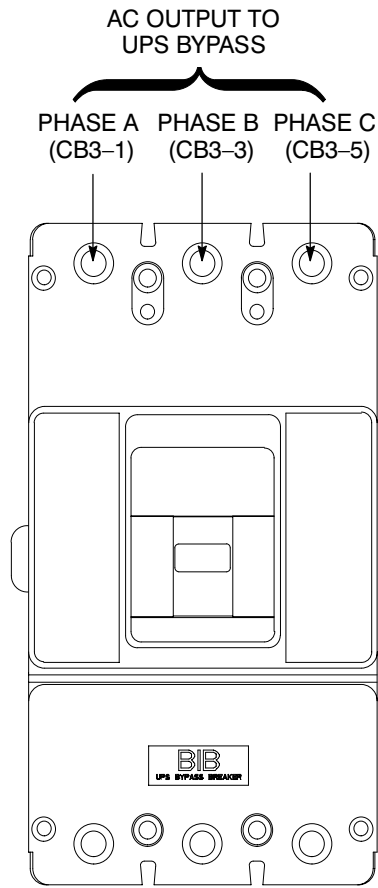

BIB (CB 3)

RIB (CB 4)

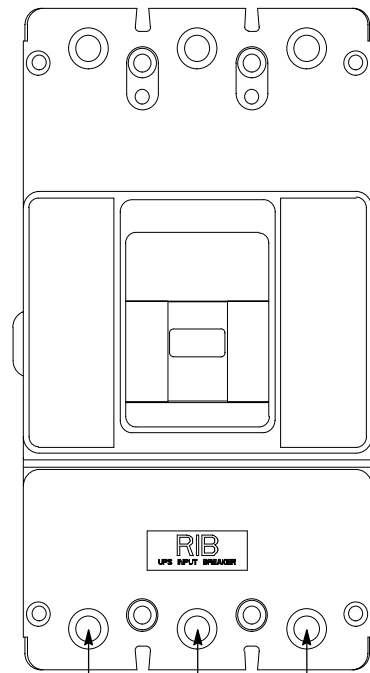

PHASE A (CB4-2) PHASE B (CB4-4) PHASE C (CB4-6)

AC OUTPUT TO UPS RECTIFIER

DESCRIPTION: IDC POWER TERMINAL LOCATIONS (208V)		
DRAWING NO: 164201690-7	SHEET: 5 of 6	
REVISION: A	DATE: 050107	

OUTPUT BREAKER TERMINAL DETAIL

RIGHT SIDE BREAKERS (CB 11, CB12, CB13)

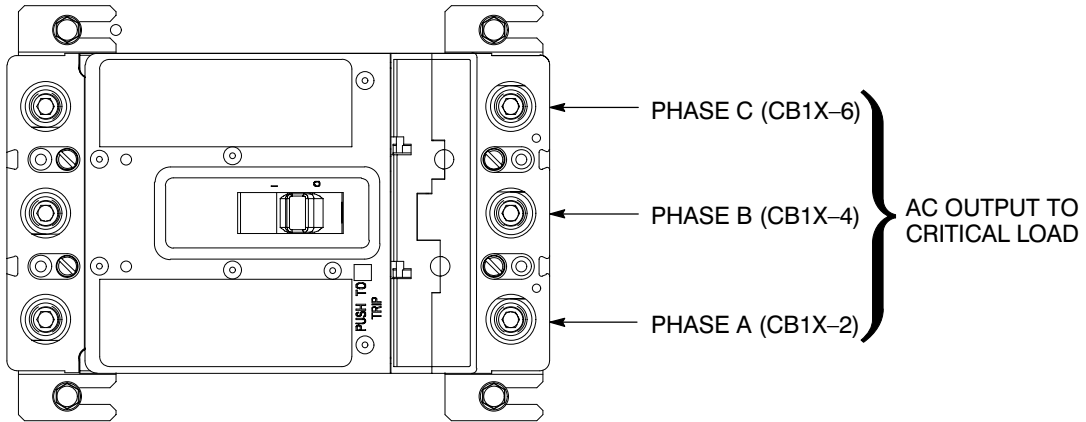

LEFT SIDE BREAKERS (CB 21, CB22, CB23)

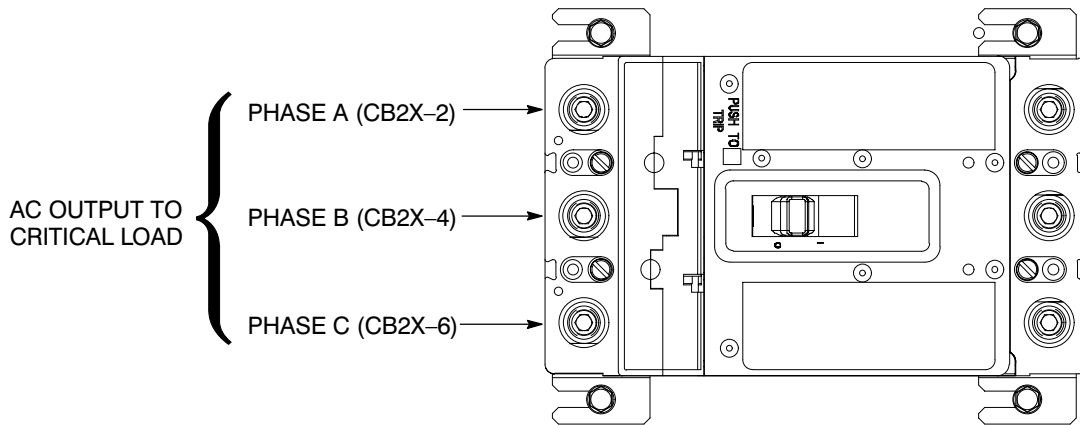

208V OUTPUT

DESCRIPTION: IDC POWER TERMINAL LOCATIONS (208V)	
DRAWING NO: 164201690-7	SHEET: 6 of 6
REVISION: A	DATE: 050107

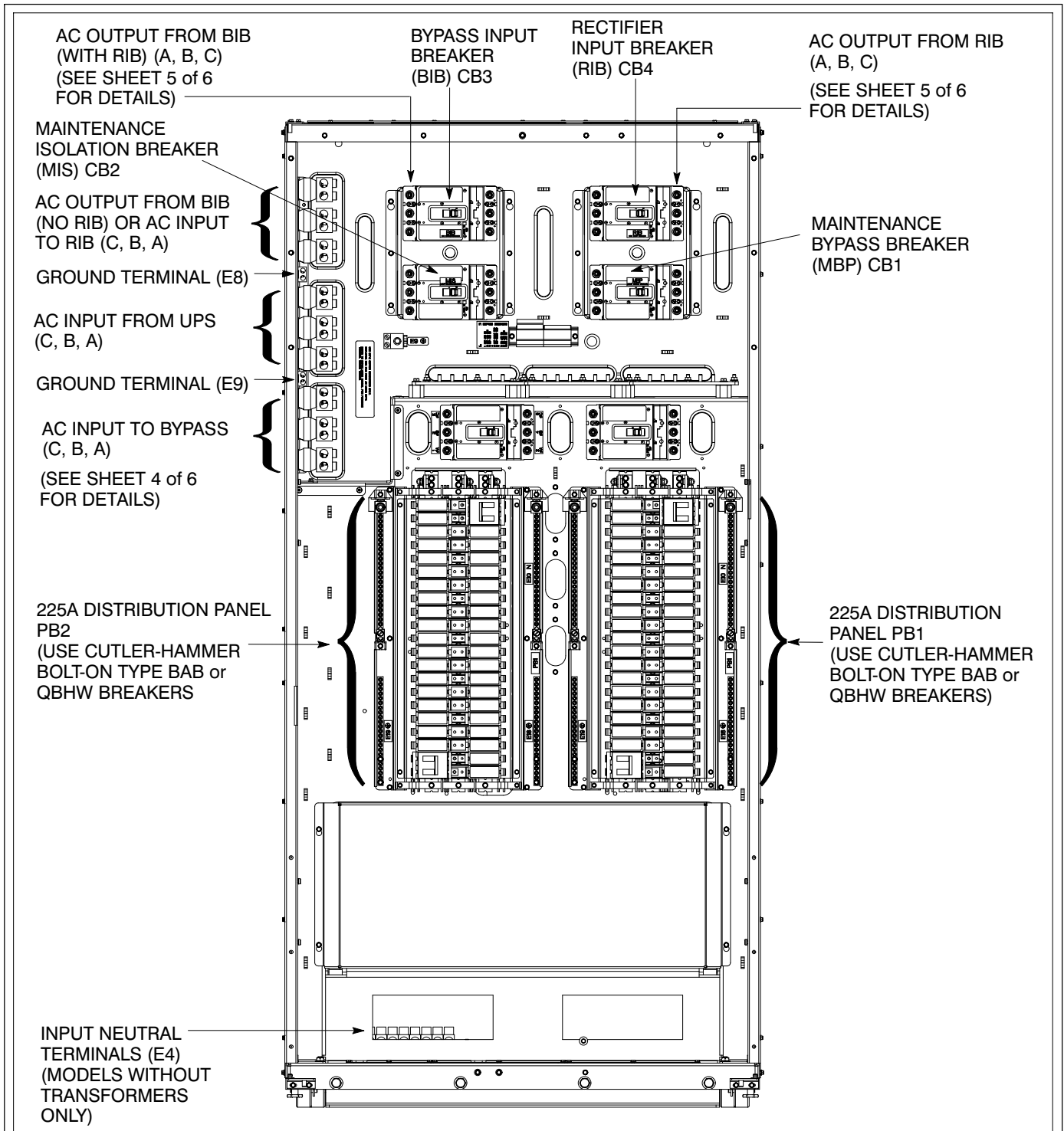

40 kVA/208V, 80 kVA/480V INPUT with OUTPUT DISTRIBUTION PANEL OPTION

NOTE: Metal shields covering wiring terminals must be removed or opened to gain access to terminals.

DESCRIPTION: IDC POWER TERMINAL LOCATIONS (480V)	
DRAWING NO: 164201690-8	SHEET: 1 of 6
REVISION: B	DATE: 082707

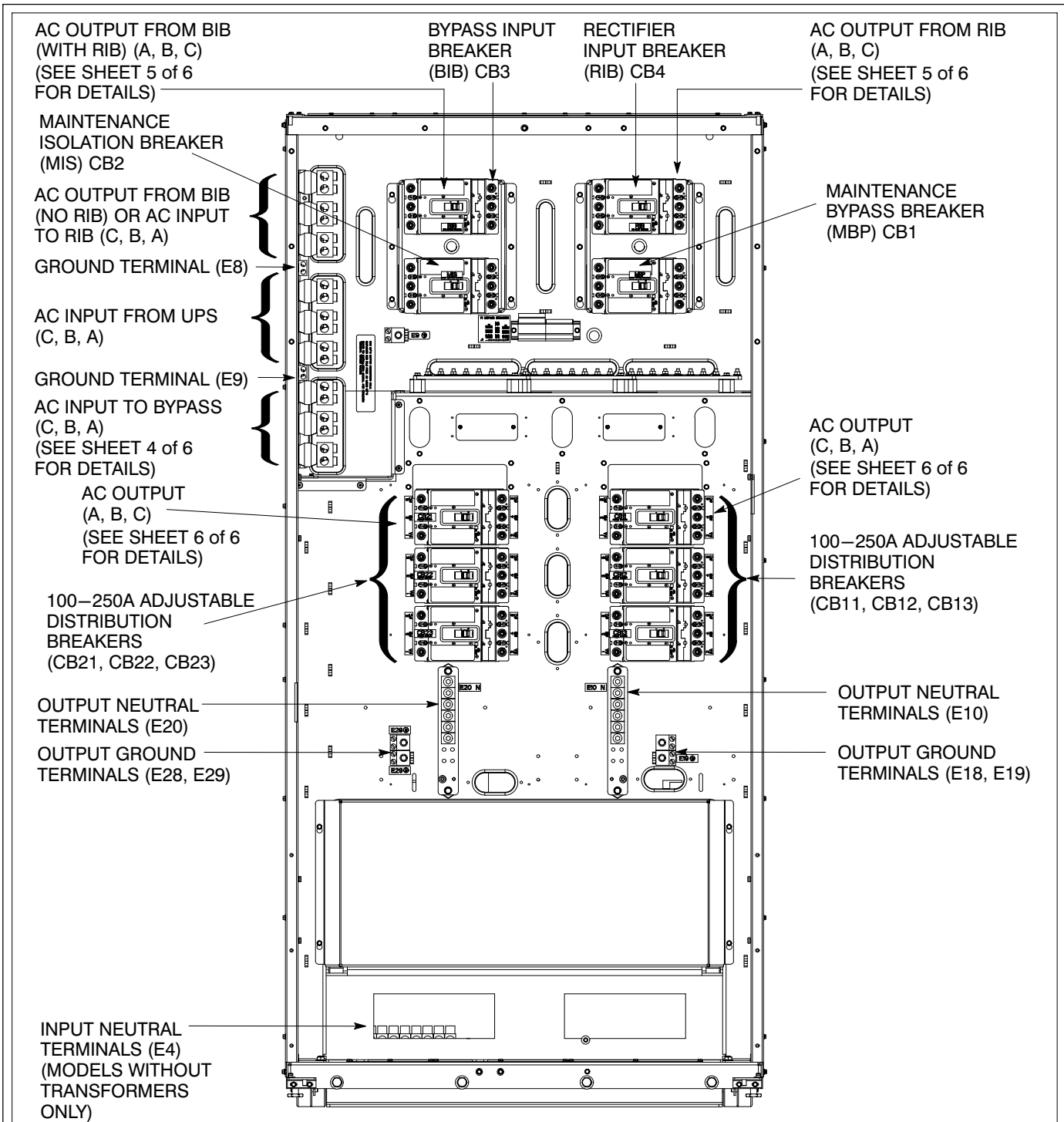

40 kVA/208V, 80 kVA/480V INPUT with OUTPUT DISTRIBUTION BREAKER OPTION

NOTE: Metal shields covering wiring terminals must be removed or opened to gain access to terminals.

DESCRIPTION: IDC POWER TERMINAL LOCATIONS (480V)	
DRAWING NO: 164201690-7	SHEET: 2 of 6
REVISION: B	DATE: 082707

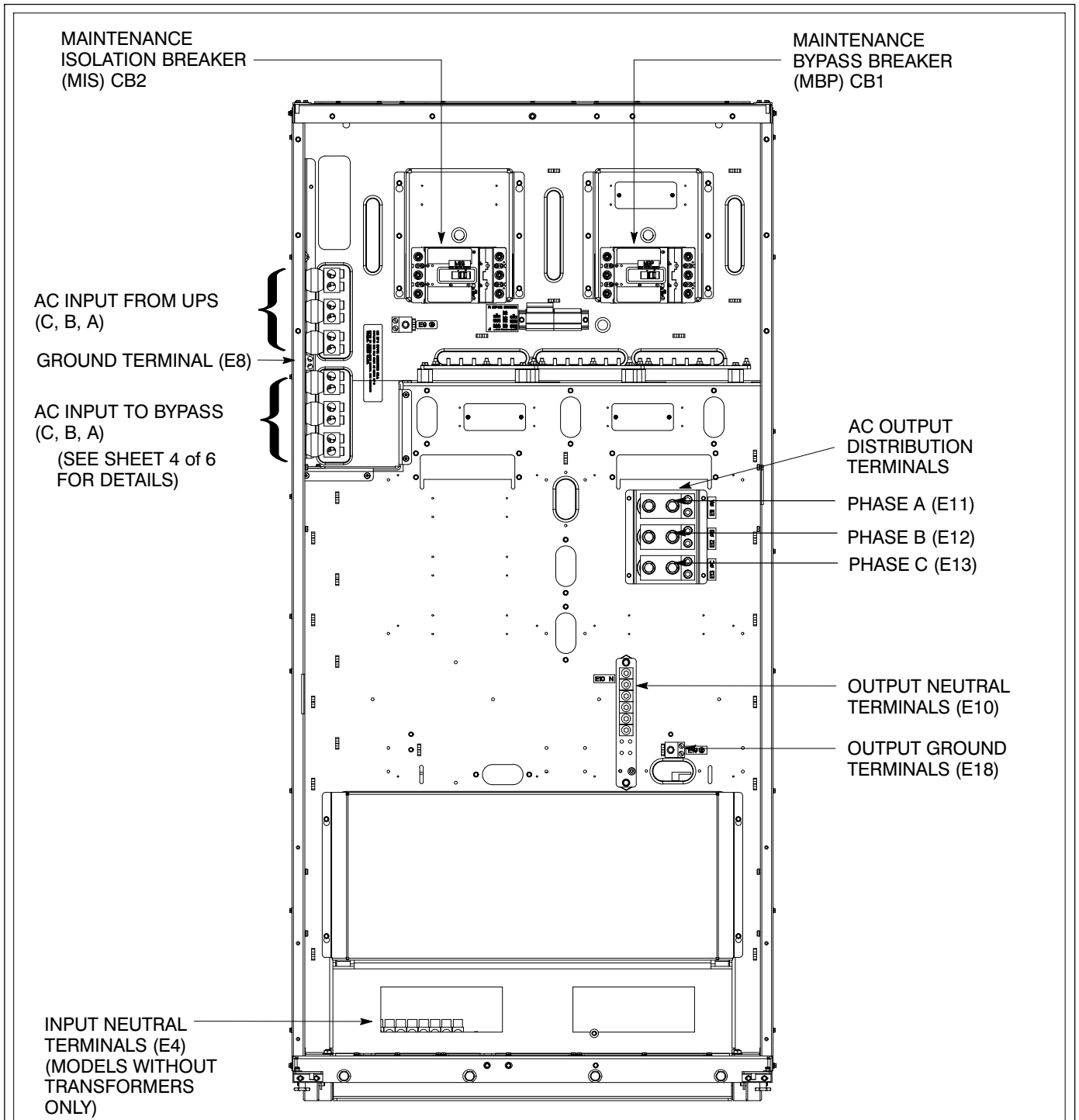

40 kVA/208V, 80 kVA/480V INPUT with OUTPUT TERMINAL BLOCK OPTION

NOTE: Metal shields covering wiring terminals must be removed or opened to gain access to terminals.

DESCRIPTION: IDC POWER TERMINAL LOCATIONS (480V)		
DRAWING NO:	164201690-7	SHEET: 3 of 6
REVISION:	B	DATE: 082707

MAINTENANCE BYPASS INPUT TERMINAL DETAIL

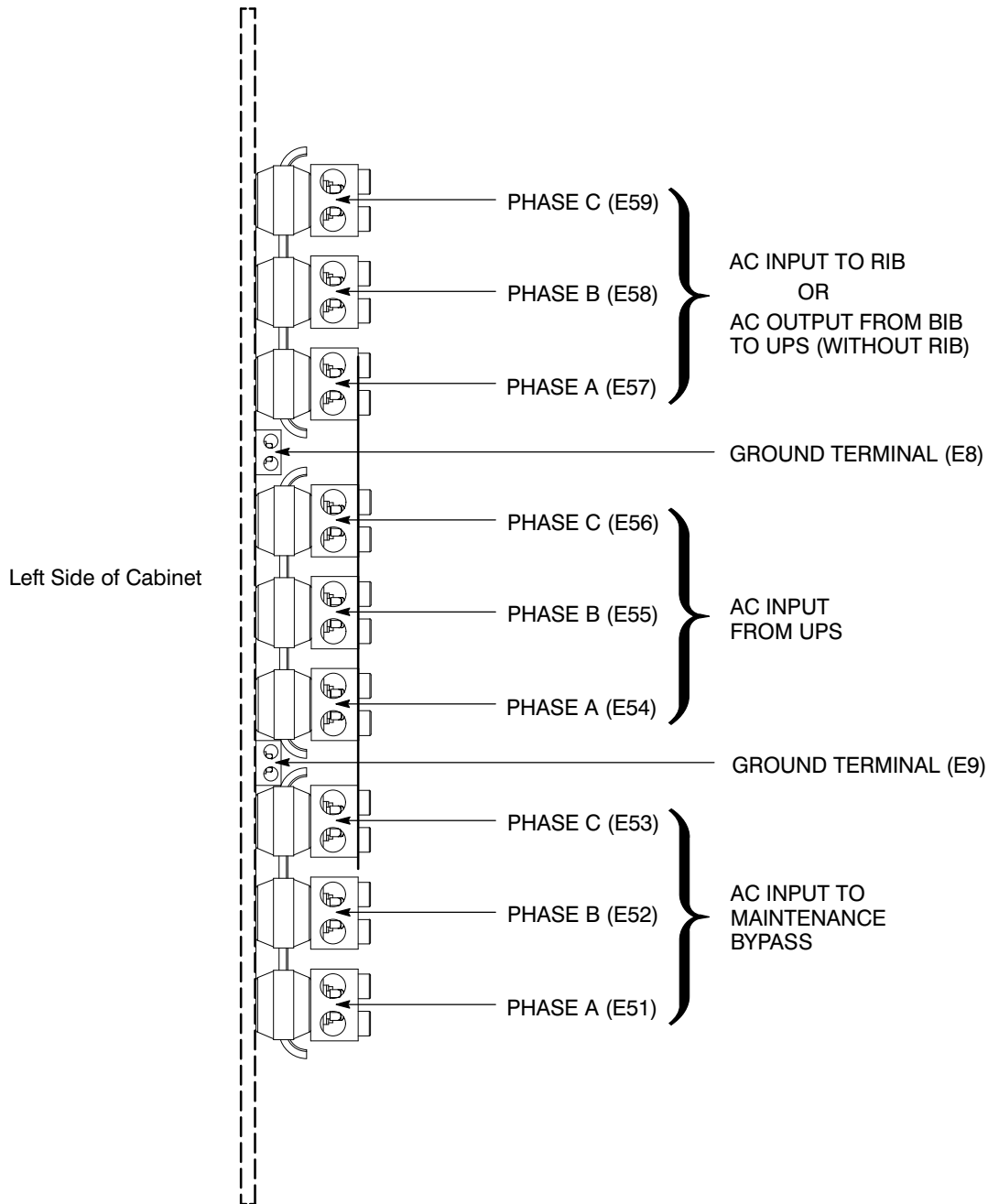

DESCRIPTION: IDC POWER TERMINAL LOCATIONS (480V)	
DRAWING NO: 164201690-7	SHEET: 4 of 6
REVISION: A	DATE: 050107

BIB AND RIB TERMINAL DETAIL

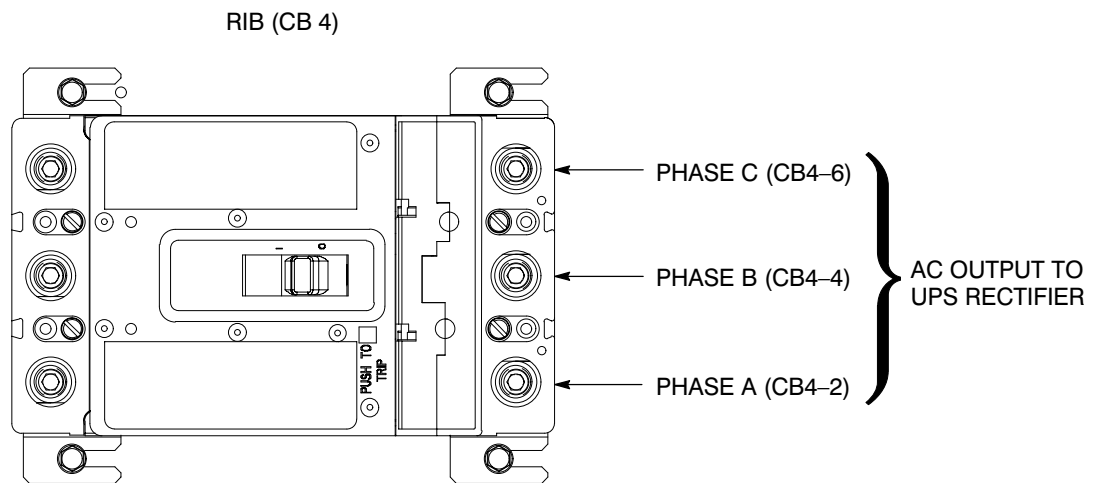
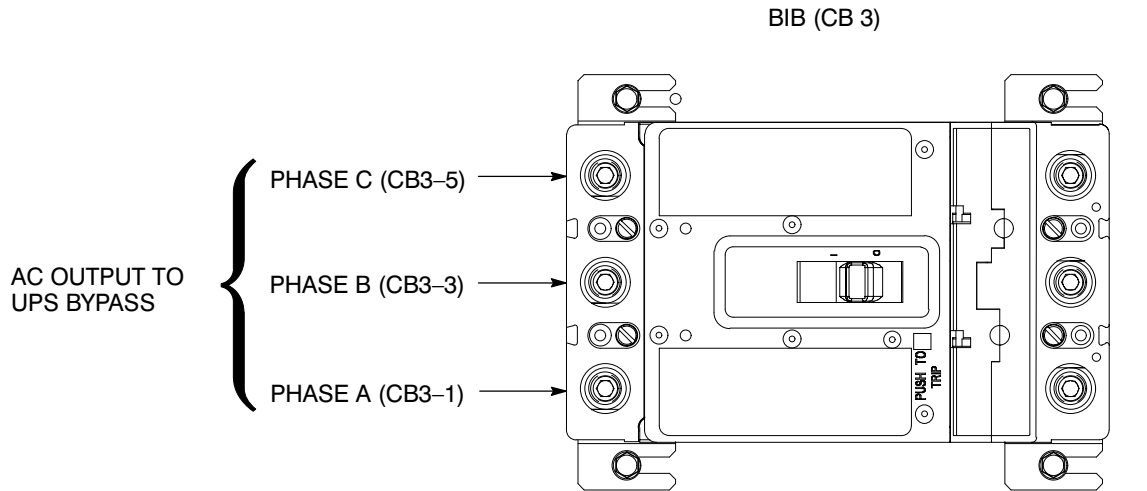

DESCRIPTION: IDC POWER TERMINAL LOCATIONS (480V)	
DRAWING NO: 164201690-7	SHEET: 5 of 6
REVISION: A	DATE: 050107

OUTPUT BREAKER TERMINAL DETAIL

RIGHT SIDE BREAKERS (CB 11, CB12, CB13)

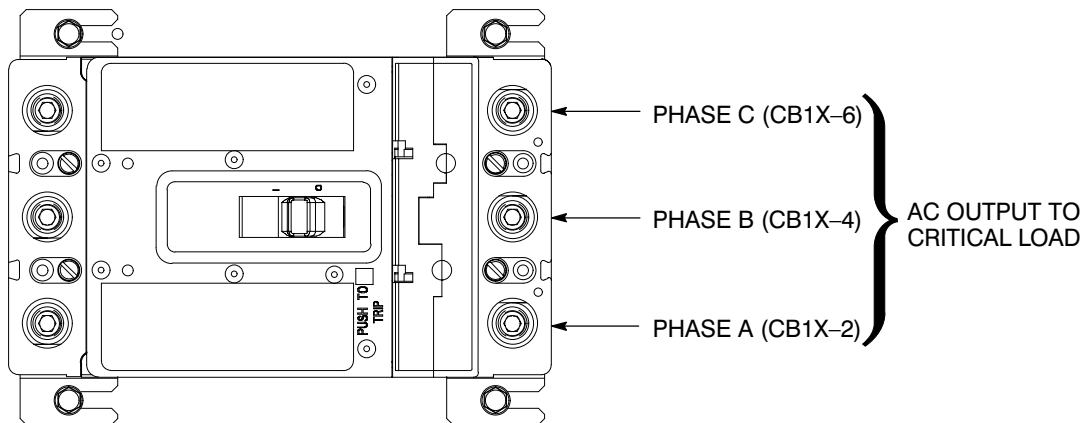

LEFT SIDE BREAKERS (CB 21, CB22, CB23)

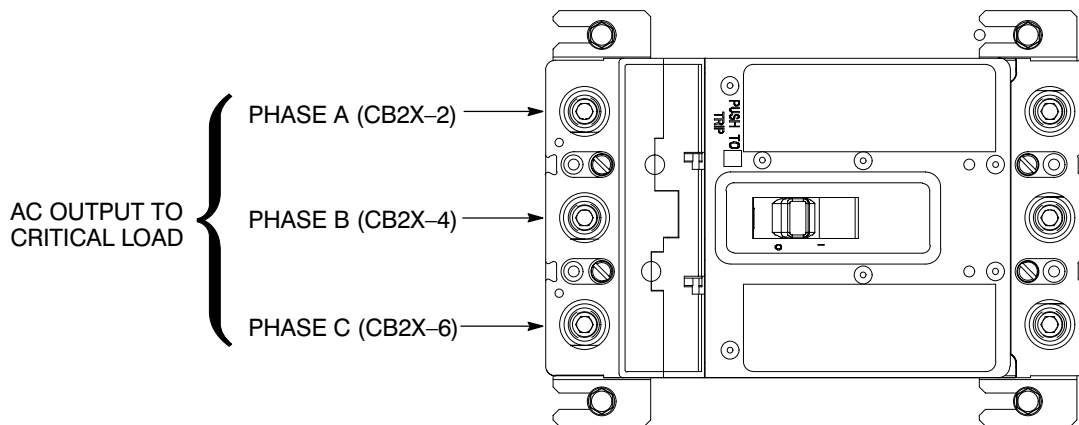

DESCRIPTION: IDC POWER TERMINAL LOCATIONS (480V)	
DRAWING NO: 164201690-7	SHEET: 6 of 6
REVISION: A	DATE: 050107

1. Use Class 1 wiring methods (as defined by the NEC) for control wiring. The wire should be rated at 600 volts, 1A minimum and 12 AWG maximum. Use twisted-pair wires for each input and common. All control wiring is customer provided.
2. When installing control wiring (such as for shunt trip or aux contacts) to the IDC interface terminals, conduit must be installed between the UPS cabinet or device and the IDC. Install the control wiring in separate conduit from the power wiring.
3. Regardless of assignment, alarms display as Building Alarm 1 and Building Alarm 2, on the UPS control panel.
4. Refer to Table J, the following sheets of this drawing, and to Chapter 3 for customer interface and control wiring.
5. Shunt trip wiring should be a minimum of 18 AWG.
6. An external 120 Vac source is required to operate the shunt trip on the IDC input breaker.
7. The REPO feature opens IDC circuit breaker CB1, all contactors in the UPS cabinet, if wired, and isolates power from your critical load. Local electrical codes may also require tripping upstream protective devices to the UPS.
8. The REPO switch is provided by the customer. The REPO switch must be a latching-type switch with a dedicated circuit.

IDC Terminal P1	Name	UPS Terminal	Description
1	MBP (CB1) Aux Contact NO	TB1-9	Contacts used to indicate whether IDC is in Maintenance Bypass mode. Contacts are closed when in Bypass mode.
2	MBP (CB1) Aux Contact Return	TB1-10	
3	MBP (CB1) Aux Contact NC	N/A	Not Used
4	Not Used	N/A	Not Used
5	MBP (CB1) Shunt Trip	N/A	When activated by a REPO switch, opens CB1 and removes all power from the critical load.
6	MBP (CB1) Shunt Trip Return	N/A	
7	Not Used	N/A	Not Used
8	MIS (CB3) Aux Contact NO	N/A	Not Used
9	MIS (CB3) Aux Contact Return	N/A	
10	MIS (CB3) Aux Contact NC	N/A	

<i>DESCRIPTION:</i> INTERFACE AND CONTROL WIRING INSTALLATION NOTES AND TERMINAL LOCATIONS	
<i>DRAWING NO:</i> 164201690-9	<i>SHEET:</i> 1 of 5
<i>REVISION:</i> A	<i>DATE:</i> 050107

TERMINAL LOCATIONS (80 kVA/208V)

TERMINAL PLUG P1

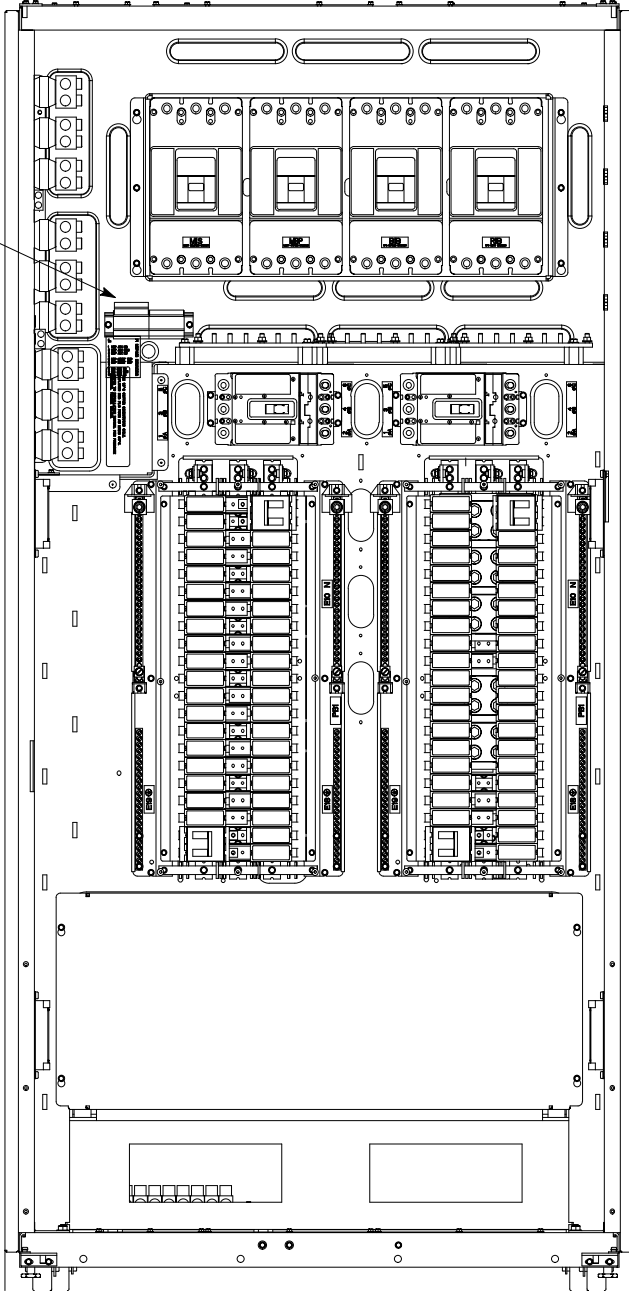

NOTE: Metal shields covering wiring terminals must be removed or opened to gain access to terminals.

DESCRIPTION: INTERFACE AND CONTROL WIRING INSTALLATION NOTES AND TERMINAL LOCATIONS	
DRAWING NO: 164201690-9	SHEET: 2 of 5
REVISION: B	DATE: 082707

TERMINAL LOCATIONS (40 kVA/208V, 80 kVA/480V)

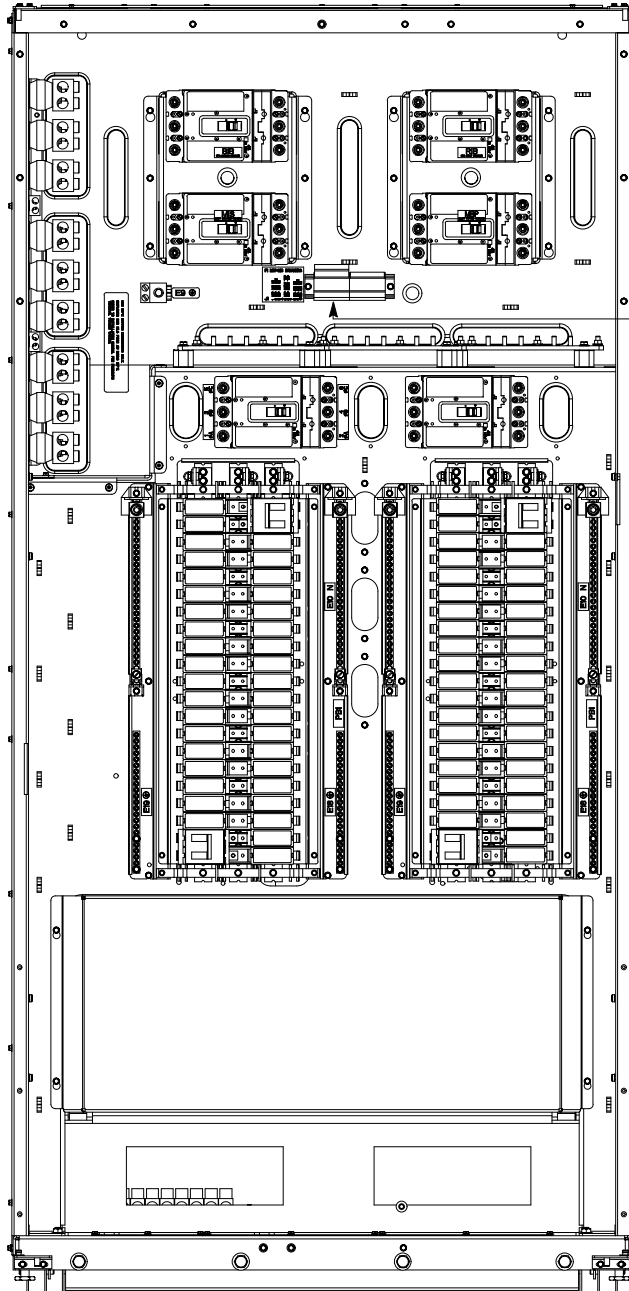

TERMINAL PLUG P1

NOTE: Metal shields covering wiring terminals must be removed or opened to gain access to terminals.

DESCRIPTION: INTERFACE AND CONTROL WIRING INSTALLATION NOTES AND TERMINAL LOCATIONS	
DRAWING NO: 164201690-9	SHEET: 3 of 5
REVISION: B	DATE: 082707

TERMINALS (rotated 90° clockwise for clarity)

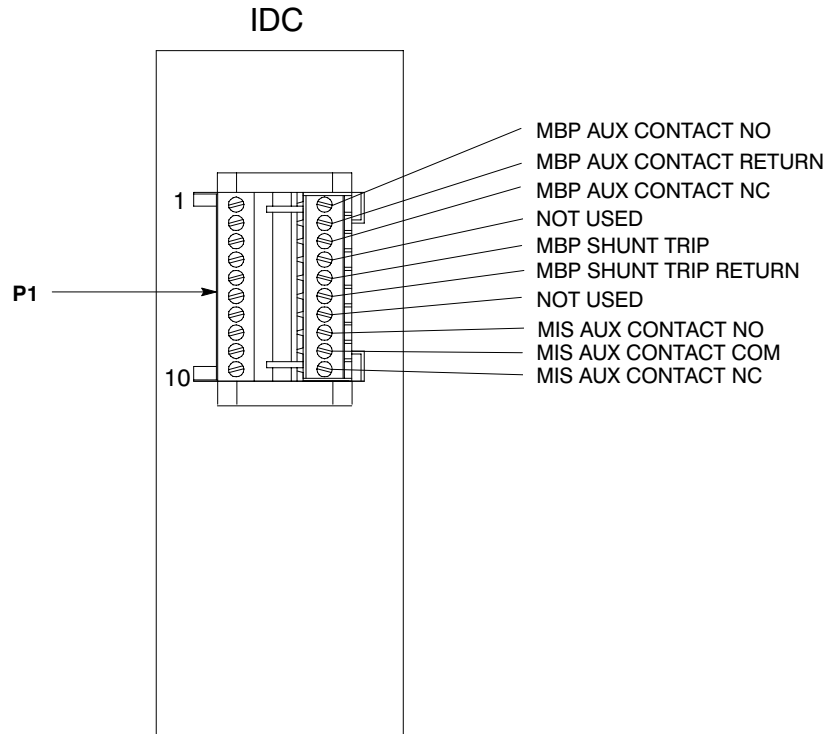

NOTE: 1. *Regardless of assignment, alarms display as Building Alarm 1 and Building Alarm 2, on the UPS control panel. Use twisted-pair wires for each alarm input and common.*

<i>DESCRIPTION:</i>	INTERFACE AND CONTROL WIRING INSTALLATION NOTES AND TERMINAL LOCATIONS	
<i>DRAWING NO:</i>	164201690-9	<i>SHEET:</i> 4 of 5
<i>REVISION:</i>	A	<i>DATE:</i> 050107

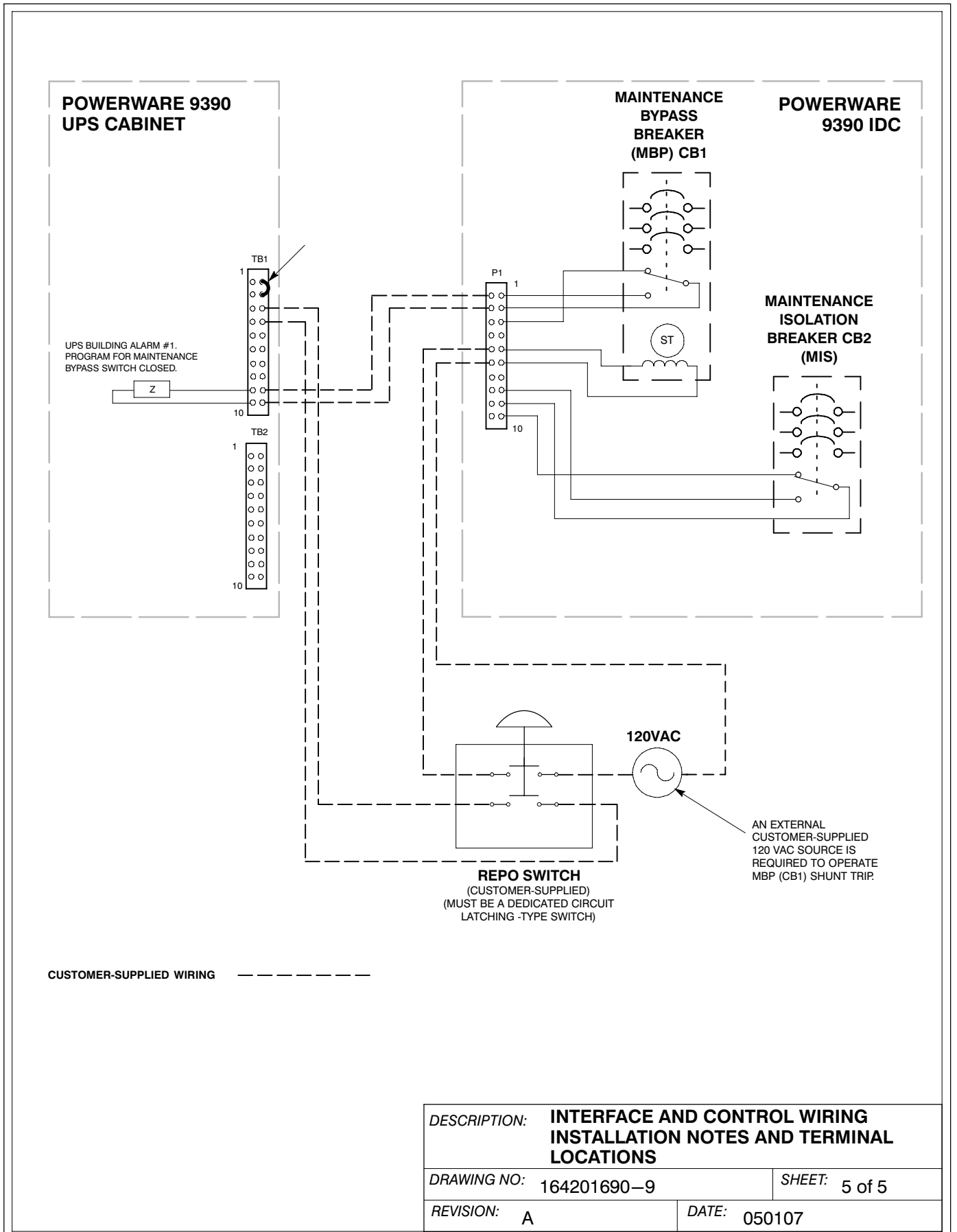

DESCRIPTION: INTERFACE AND CONTROL WIRING INSTALLATION NOTES AND TERMINAL LOCATIONS	
DRAWING NO: 164201690-9	SHEET: 5 of 5
REVISION: A	DATE: 050107

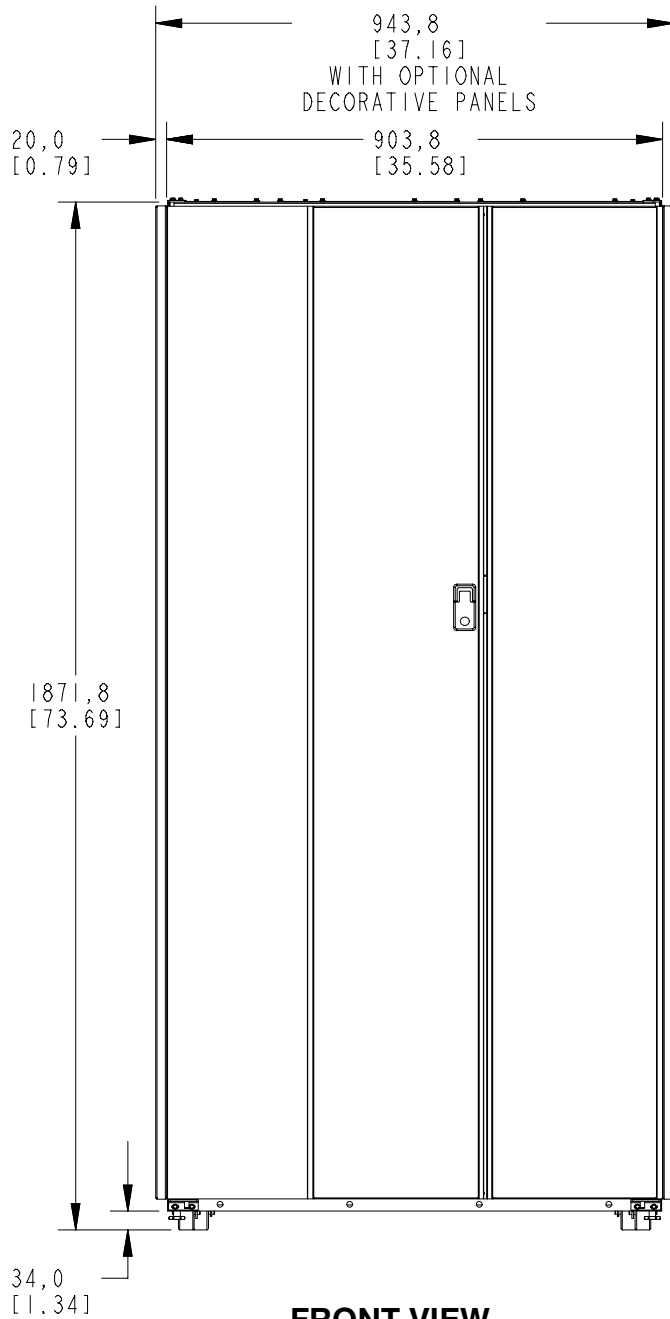

FRONT VIEW

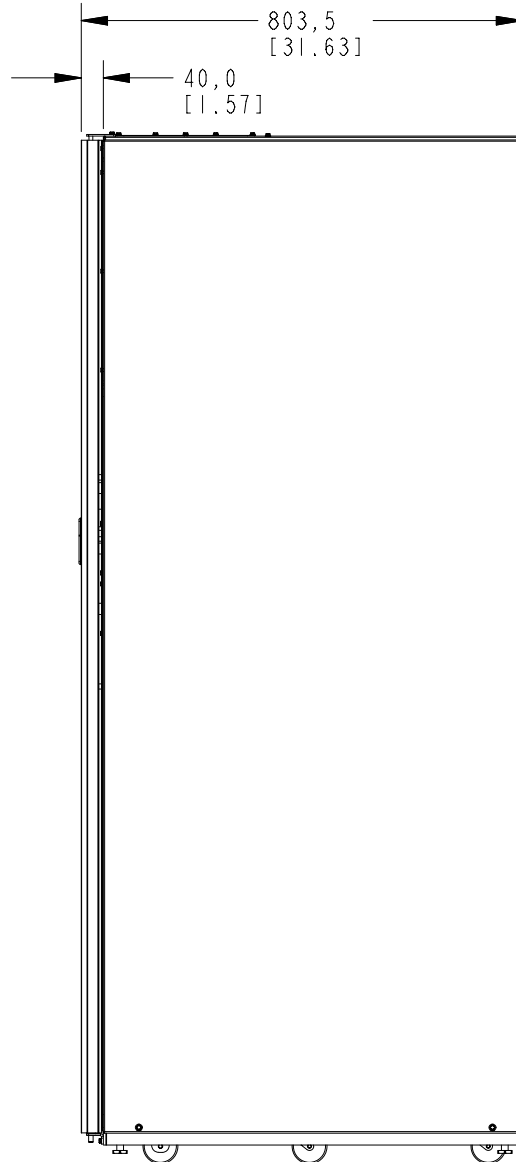

RIGHT SIDE VIEW

DESCRIPTION: IDC DIMENSIONS	
DRAWING NO: 164201690-10	SHEET: 1 of 4
REVISION: A	DATE: 050107

Dimensions are in millimeters (inches)

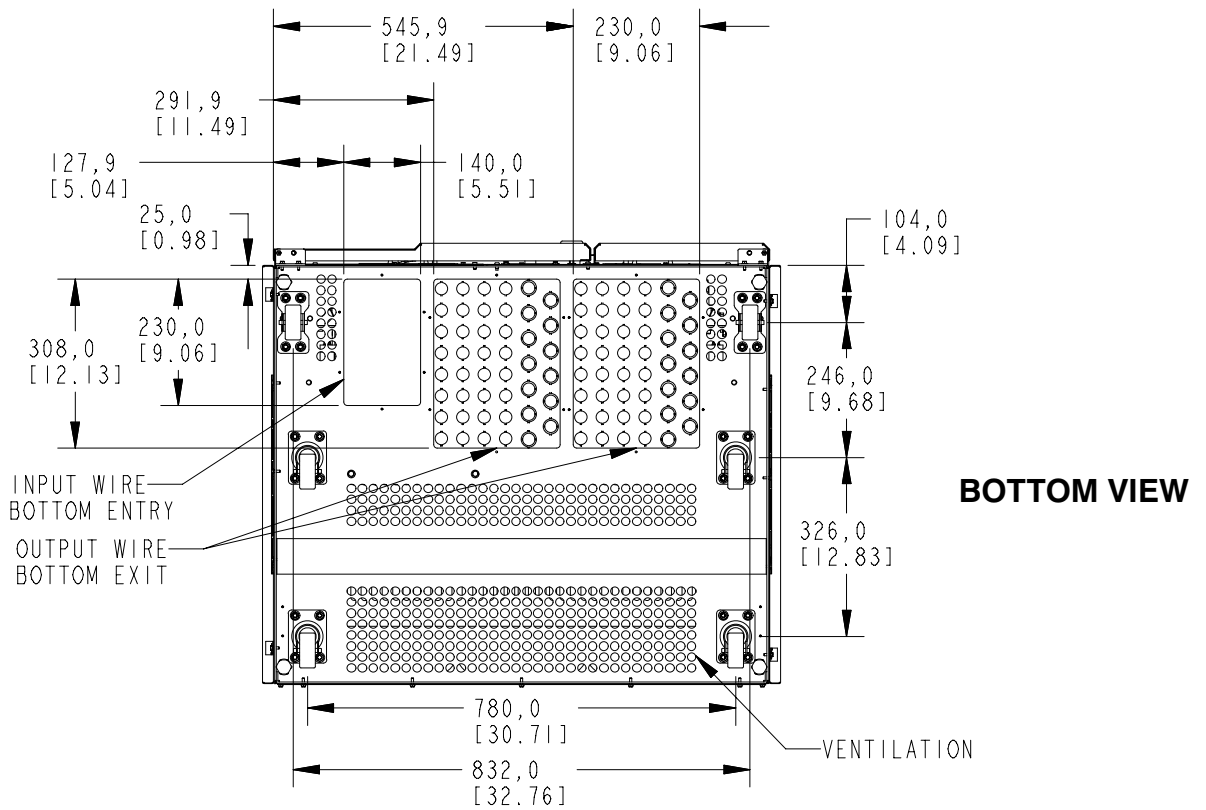
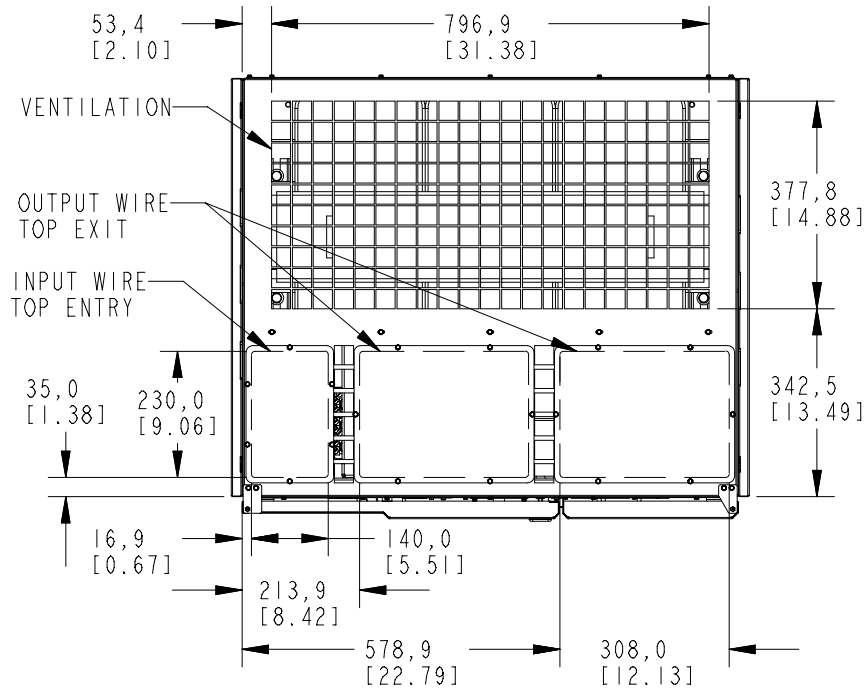

DESCRIPTION: IDC DIMENSIONS	
DRAWING NO: 164201690-10	SHEET: 2 of 4
REVISION: A	DATE: 050107

Dimensions are in millimeters (inches)

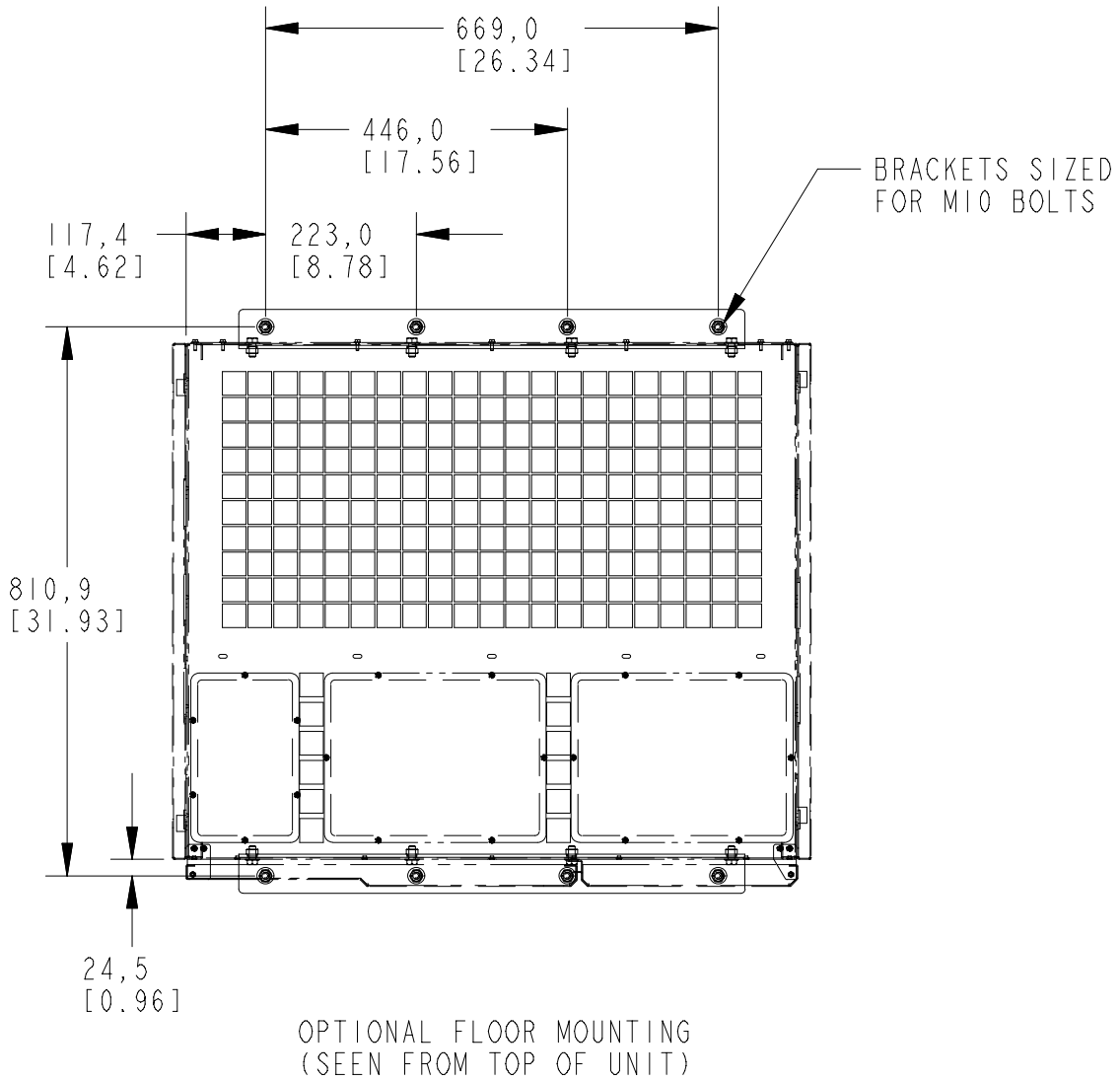

Dimensions are in millimeters (inches)

DESCRIPTION: IDC DIMENSIONS	
DRAWING NO: 164201690-10	SHEET: 3 of 4
REVISION: A	DATE: 050107

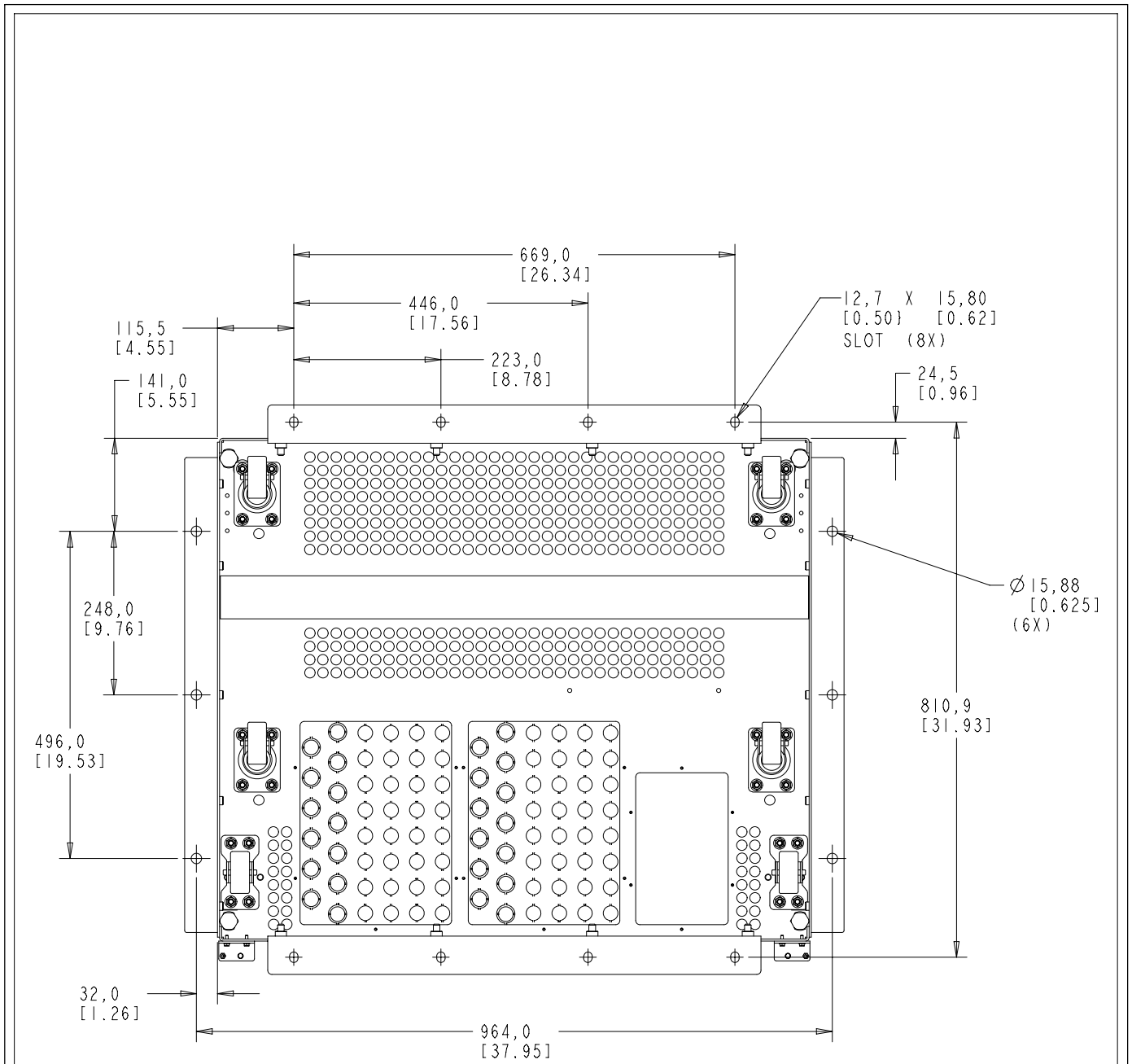

FRONT

80 IDC SEISMIC MOUNTING

Dimensions are in millimeters (inches)

DESCRIPTION: IDC DIMENSIONS	
DRAWING NO: 164201690-10	SHEET: 4 of 4
REVISION: A	DATE: 050107

This page intentionally left blank.



164201690 2