



**Powerware®**

**9315**

Maintenance Bypass Module  
200–500 kVA

---

INSTALLATION & OPERATION MANUAL

## **IMPORTANT SAFETY INSTRUCTIONS**

Instructions Importantes Concernant La Sécurité

### **SAVE THESE INSTRUCTIONS**

Conserver Ces Instructions

**This manual contains important instructions for your Uninterruptible Power Supply (UPS) system. You should follow these instructions during the installation and maintenance of the UPS, options, accessories, and batteries.**

Cette notice contient des instructions importantes concernant la sécurité.

This equipment has been tested and found to comply with the limits for a Class A digital device, pursuant to Part 15 of the FCC Rules. These limits are designed to provide reasonable protection against harmful interference when the equipment is operated in a commercial environment. This equipment generates, uses, and can radiate radio frequency energy and, if not installed and used in accordance with the instruction manual, may cause harmful interference to radio communications. Operation of this equipment in a residential area is likely to cause harmful interference in which case the user will be required to correct the interference at their own expense.

**WARNING:**

**This is a product for restricted sales distribution to informed partners. Installation restrictions or additional measures may be needed to prevent disturbances.**

# Table of Contents

<b>1 Introduction</b> .....	<b>1</b>
Using This Manual .....	3
Conventions Used in This Manual .....	3
For More Information .....	4
Getting Help .....	4
<b>2 Getting Started</b> .....	<b>5</b>
Preparing the Site .....	6
Creating an Installation Plan .....	6
Environmental Considerations .....	6
Preparing for Wiring the Maintenance Bypass Module .....	6
Inspecting and Unpacking the Maintenance Bypass Module .....	7
Unloading the MBM from the Pallet .....	9
<b>3 Installing and Wiring the Maintenance Bypass Module</b> ....	<b>11</b>
Line and Load Wiring .....	14
<b>4 Maintenance Bypass Module Operation</b> .....	<b>15</b>
Preliminary Checks and Startup for UPS Equipped with Maintenance Bypass Module .....	15
Maintenance Bypass Module Operation .....	15
MBM Operation Without Kirk Key Interlocks .....	16
MBM Operation With Kirk Key Interlocks (Optional) .....	17
Kirk Key Solenoid Release Unit (SKRU) .....	17
MBM Transfer Sequences .....	17
Maintenance .....	19
Short Circuits .....	19
Maintenance Bypass Module Diagrams .....	19
<b>Appendix A</b> .....	<b>A-1</b>

# List of Figures

Figure 1.	Typical 200–300kVA MBM without Transformer .....	1
Figure 2.	Typical 225–300kVA MBM with Auto/Isolation Transformer .....	2
Figure 3.	Front and Side View of Typical Maintenance Bypass Module on Shipping Pallet (PWP 200–300kVA w/o XFMR) .....	5
Figure 4.	MBM as Shipped, with Outer Packaging and Pallet .....	7
Figure 5.	Detail of Shipping Supports .....	10
Figure 6.	Top, Bottom, and Front View of Maintenance Bypass Module (200–300kVA w/o XFMR) .....	11
Figure 7.	Top, Bottom, and Front View of Maintenance Bypass Module with Auto/Isolation Transformer for PWP 225–300kVA UPS .....	12
Figure 8.	Typical Power Wiring Terminations of UPS Module and Maintenance Bypass Module without Auto/Isolation Transformer (200–300kVA) .....	13

# 1

## Introduction

The Maintenance Bypass Module (MBM) is a free-standing cabinet containing a Maintenance Isolation circuit breaker (MIS), and a Maintenance Bypass circuit breaker (MBP). An optional UPS Module Input Bypass circuit breaker (BIB) is available. Figure 1 shows a typical MBM cabinet without transformer for the Powerware 9315 (200 kVA–500 kVA) UPS. Figure 2 shows a typical MBM cabinet with stepdown isolation/auto transformer for Powerware 9315 (225 kVA–300 kVA) UPS.

The equipment and devices described in this manual are provided for operation with the specific UPS Modules (model and rating) described in the appendix.

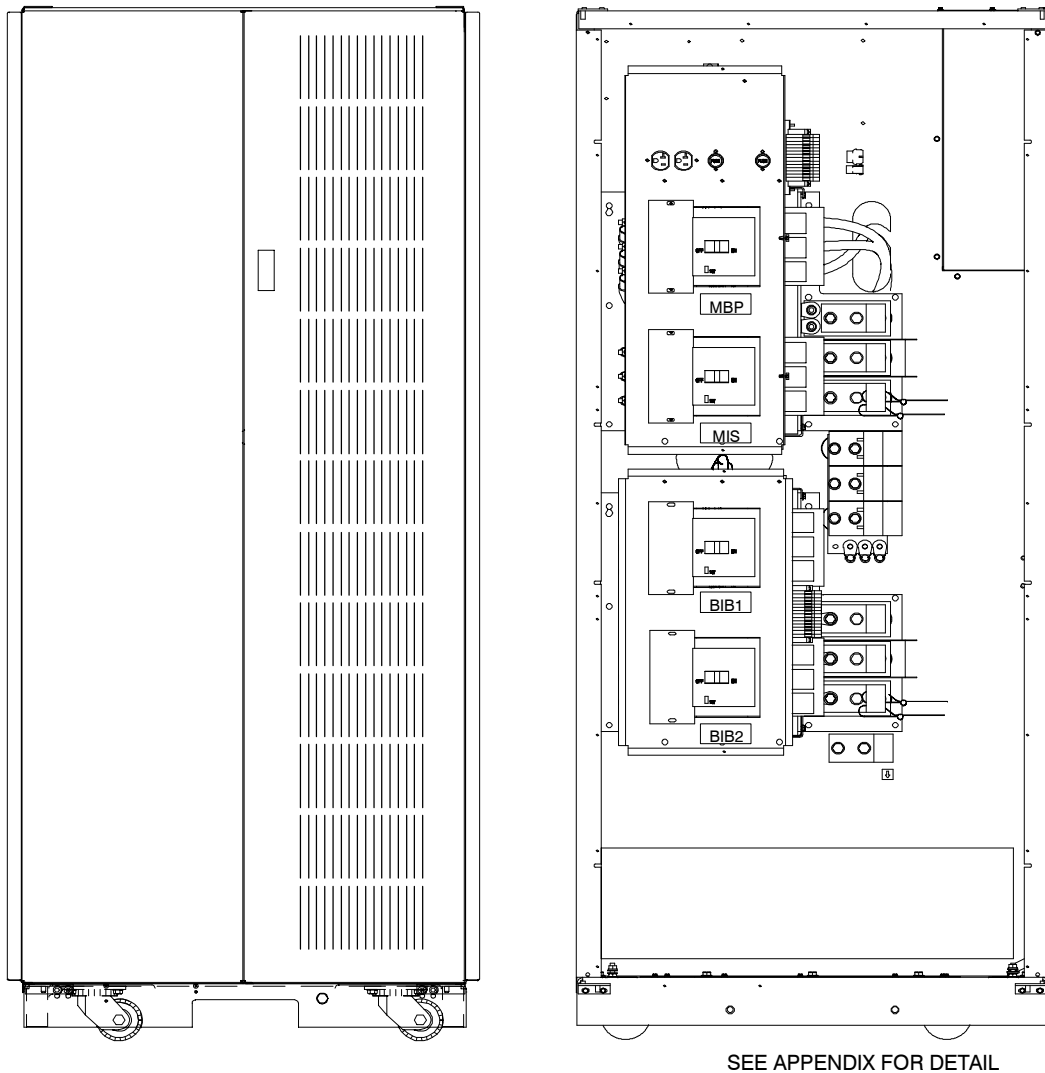

**Figure 1. Typical 200–500 kVA MBM without Transformer.**

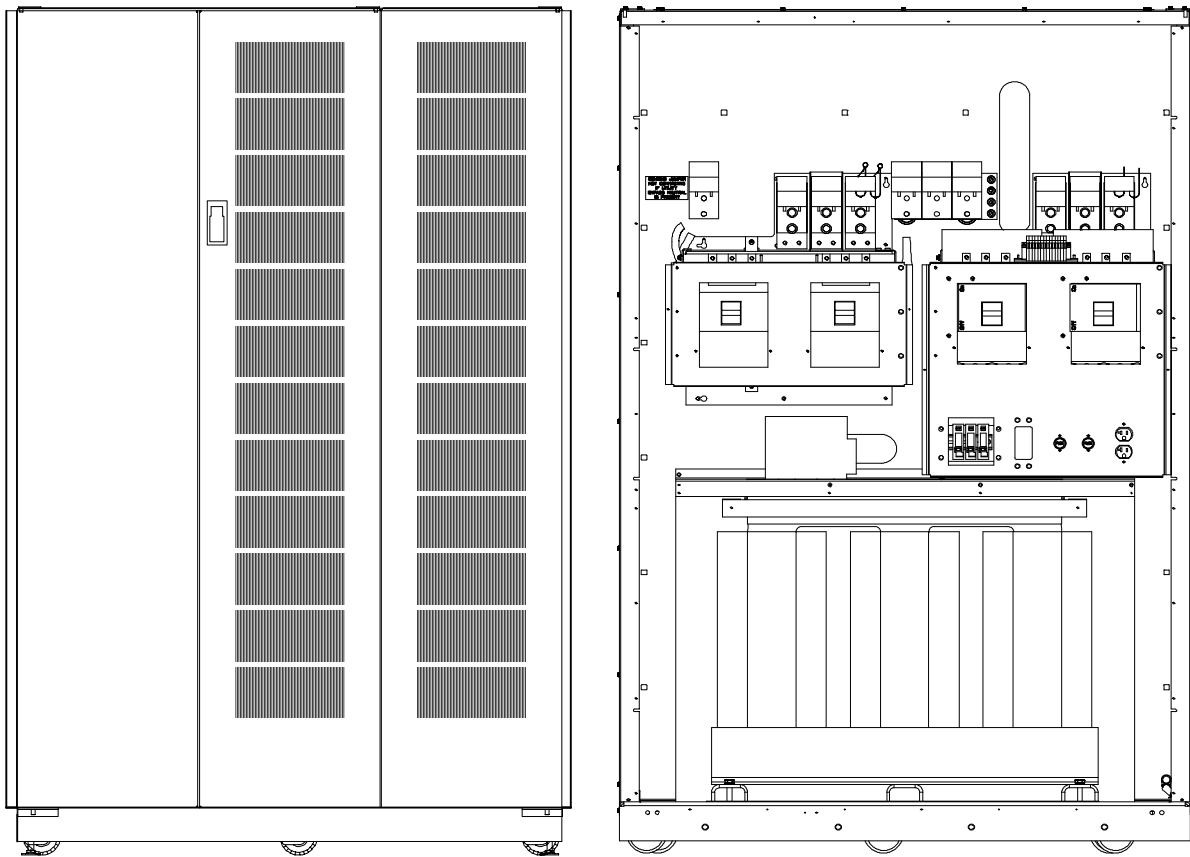

SEE APPENDIX FOR DETAIL

**Figure 2. Typical 225–300 kVA MBM with Auto/Isolation Transformer**

## Using This Manual

---

This manual contains installation and operation procedures for the MBM. Before installation and operation, read through each procedure.

- Chapter 1 provides an overview of this manual and references for further information.
- Chapter 2 tells you how to prepare your site for the installation of the MBM. It discusses equipment environmental requirements, inspecting, and unpacking cabinets.
- Chapter 3 describes how to install the MBM cabinet.
- Chapter 4 contains operating information for the MBM.
- Appendix A contains important information for planning and installing the MBM, including wiring data and illustrations of cabinets.

## Conventions Used in This Manual

---

This manual contains installation and operation procedures for the Maintenance Bypass module.

- **Bold type** highlights important concepts in discussions, key terms in procedures, and menu options.
- *Italic type* highlights notes, references to other system manuals, references to other sections of this manual, and new terms where they are defined.
- Rectangular boxes containing bold type are warnings or cautions that pertain to the system or its electrical connections. This important information indicates possible dangers pertaining to personnel safety, equipment damage, critical load protection, or operational concerns.

## For More Information

---

For more information on the installation and operation of the UPS system and its accessories, refer to the following:

**164201036**      ***Powerware® 9315 (200 kVA – 300 kVA) UPS Operation***

**164201119**      ***Powerware® 9315 (400 kVA – 500 kVA) UPS Operation***

This manual describes the UPS cabinet, Control Panel, and Monitor Panel, and explains the functions of the UPS; discusses the standard features of the UPS and optional accessories; provides procedures for starting and stopping the UPS, and information about maintenance and responding to system events.

These also describe the RS–485 and RS–232 serial communications capabilities of the UPS system; discuss the two communications ports on the Customer Interface Panel inside the UPS and how to connect optional remote accessories to your UPS system; and provide information about enabling, disabling, and customizing building alarms.

**164201037**      ***Powerware® 9315 (200 kVA – 300 kVA) UPS Installation***

**164201118**      ***Powerware® 9315 (400 kVA – 500 kVA) UPS Installation***

This manual contains the following information: how to prepare the site and plan for installation, detailed step-by-step procedures for installing each component of your system, how to join cabinets in a line-up-and-match system, detailed illustrations of cabinets and optional accessories, including dimensions and connection points.

Contact the local Field Service office for information on how to obtain copies of these manuals.

## Getting Help

---

If you have a question about any of the information in this manual, or if you have a question this manual does not answer, please call Powerware Corporation Field Service:

**United States**      **1-800-843-9433**

**Canada**      **1-800-461-9166**

**Outside the U.S.**      **Call your local representative**



# 2

## Getting Started

This section describes how to install the Maintenance Bypass Module (MBM). It contains instructions for installing the MBM and basic site preparation procedures. Figure 3 shows the front and side view of an MBM without transformer for a Powerware 9315 (200 kVA–500kVA) UPS module.

The MBM is shipped as a separate item. Use a forklift or pallet jack to move the packaged cabinet to the installation site, or as close as possible to the site, before unloading.

The basic sequence of the installation steps is:

1. Prepare the site for the MBM installation.
2. Inspect, unpack, and unload the MBM.
3. Create an installation plan for wiring the MBM to the UPS system.
4. Prepare for wiring.
5. Complete the installation checklist from the *Powerware® 9315 Installation* manual.
6. Have authorized service personnel perform preliminary checks and startup.

**NOTE:** *Startup and operational checks must be performed only by authorized service personnel. This service is usually offered as part of the sales contract for your UPS system.*

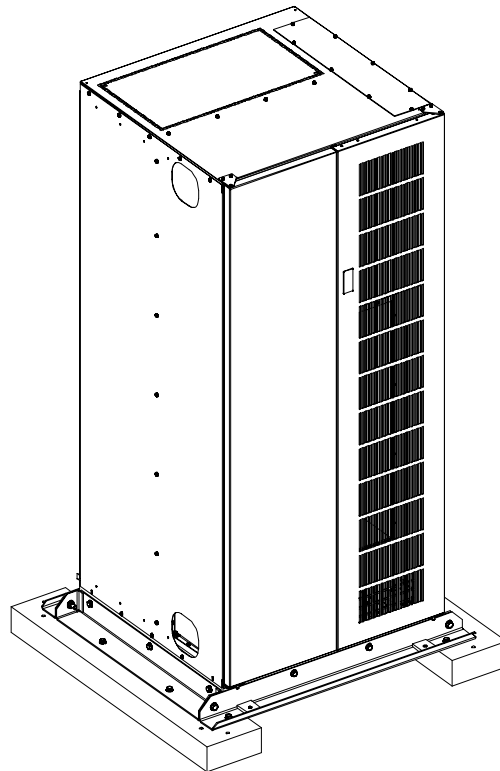

**Figure 3. Front and Side View of Typical Maintenance Bypass Module on Shipping Pallet (Powerware 9315 (200 kVA–500 kVA) w/o XFMR)**

## Preparing the Site

---

For the MBM to operate at peak efficiency, the installation site should meet the environmental parameters outlined in the *Powerware® 9315 Operation* manual provided with the UPS system. The operating environment must meet the size and weight requirements supplied in the *Powerware® 9315 Installation* manual provided with the UPS system. If the MBM is to be operated at an altitude higher than 1500 meters (5000 feet), contact the local sales or service office for important information about high altitude operation.

The basic environmental requirements for operation of the MBM are:

**Ambient Temperature Range:** 0–40°C (32–104°F)

**Recommended Operating Range:** 20–25°C (68–77°F)

**Maximum Relative Humidity:** 95% noncondensing

The MBM uses convection cooling to regulate internal component temperature. Air inlets are in the front of the cabinet, and outlets are in the top. Clearance in front of and above each cabinet for proper air circulation is essential.

## Creating an Installation Plan

---

Before beginning to install the MBM, read and understand how this manual applies to the system being installed. It is important to note that UPS module installation procedures are contained in the *Powerware® 9315 Installation* manual provided with the UPS system. It is recommended to first understand how to install the UPS modules. The information in Chapter 2 of this manual is a guide for installation of the MBM to the UPS modules.

## Environmental Considerations

---

The life of the maintenance bypass module is adversely affected if the installation does not meet the following guidelines:

1. The MBM must be installed on a sealed concrete pad or floor.
2. The MBM must be installed in a dust-free environment.
3. The MBM must be installed in a humidity-controlled environment.

## Preparing for Wiring the Maintenance Bypass Module

---

See Tables A through E in Appendix A of this manual for wiring requirements. The power wiring for this equipment is rated at 90°C. If wire is run in an ambient temperature greater than 30°C, higher temperature rating and/or larger size wire may be necessary. Wiring should be installed through the bottom or top entry of the module except MBM 225 kVA-300 kVA with Auto/Isolation transformer whose wiring should be installed through the top entry only. For UPS external wiring requirements, including minimum AWG size of external wiring, see the *Powerware® 9315 Installation* manual provided with the UPS system.

**NOTE:** *Material and labor for external wiring are to be provided by designated personnel.*

## Inspecting and Unpacking the Maintenance Bypass Module

---

The first task in preparing for installation of the MBM is inspecting and unpacking the unit. The MBM arrives covered with protective packaging material as shown in Figure 4.

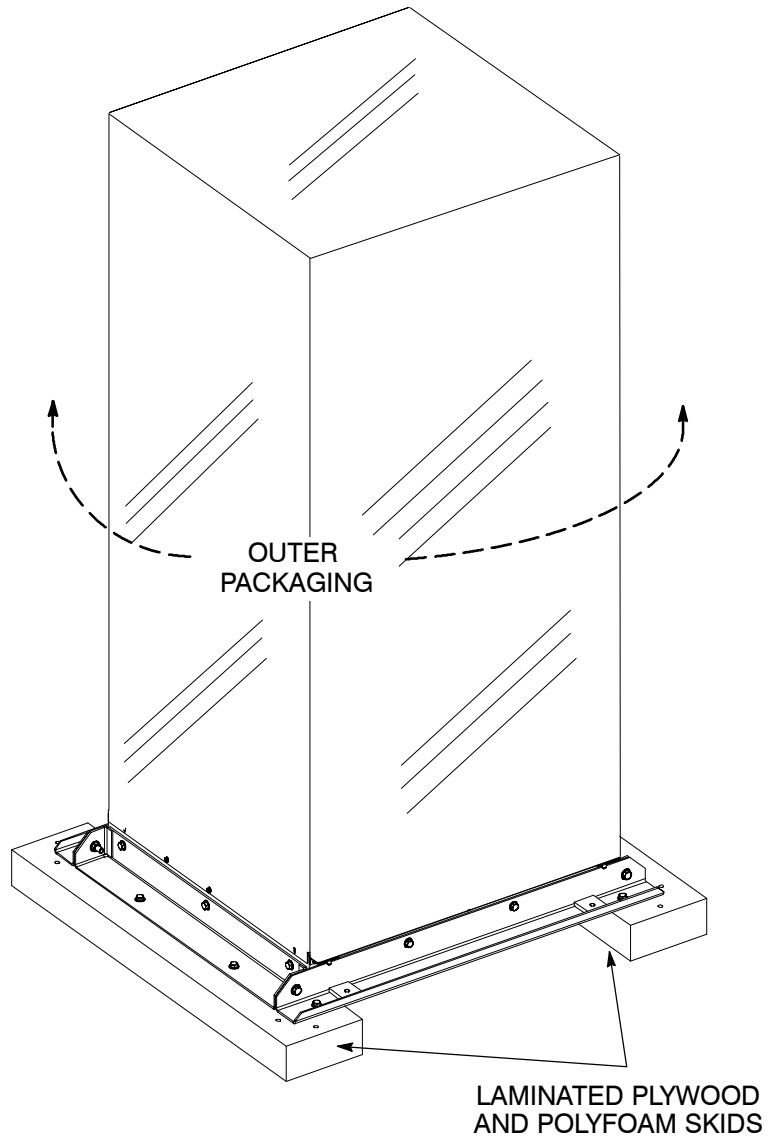

**Figure 4. MBM as Shipped, with Outer Packaging and Pallet**

1. Carefully inspect the outer packaging for evidence of damage during transit.

**CAUTION:**

**Do not install a damaged MBM. Report any damage to the carrier and contact the local sales or service office immediately.**

2. Use a forklift or other material handling equipment to move the MBM to a convenient unpacking area. Insert the forklift jacks between the laminated plywood/polyfoam skids on the bottom of the unit.

**CAUTION:**

**Do not tilt unit more than 10 degrees from vertical.**

3. Set the pallet on a firm, level surface, allowing a minimum clearance of 4.6m (15 ft) on each side for removing the MBM from the pallet.
  4. Cut the steel bands around the MBM.
  5. Remove the protective cardboard covering from the MBM, cutting where indicated, using a knife blade no longer than 25 mm (1 in.).
- NOTE:** *Do not discard the packaging material. Instructions for unloading the MBM from the pallet are printed on the cardboard. Please to refer to them.*
6. Remove the plastic bag and foam packing material. Please discard or recycle them in a responsible manner.

## **Unloading the MBM from the Pallet**

---

The MBM pallet consists of four metal angle supports secured to plywood/polyfoam laminated skids. The skids act as shock absorbers for the MBM during shipment.

**WARNING:**

**Unit is extremely heavy. If unloading instructions are not closely followed, the unit may tip and cause serious injury.**

**Turning the jacking bolts unevenly may cause the unit to become unbalanced. To prevent tipping, raise and lower the jacking bolts evenly and sequentially. The unit should only be raised approximately 3 mm (1/8 in.) above the floor (just enough to remove polyfoam skids).**

1. Remove the doors. Remove the retaining screw located inside each door at the bottom hinge pivot point, then lift off the door. Save the retaining screws for reinstallation of the doors.
2. Locate the field kit packed inside the unit. Locate the four 1/2-in. jacking bolts and install them in the threaded holes in the front and rear supports. Place a floor protector underneath each jacking bolt, and screw the bolts down until they contact the floor protectors. The floor protectors prevent the floor from being damaged by the jacking bolts.

**WARNING:**

**Module may fall. Do not loosen hardware attaching the side or front/rear shipping supports to the module base. Also, do not loosen the shipping supports from each other. The module must be lowered using jacking bolts before the shipping supports can be removed.**

3. Loosen, but do not remove the hardware holding the plywood/polyfoam skids to the front and rear supports (labeled "1" in Figure 5 – 8 places).
4. Turn each jacking bolt clockwise sequentially, no more than two full turns each, until the foam cushions clear the floor by approximately 3 mm (1/8 in.).
5. After the plywood/polyfoam skids clear the floor, remove the hardware loosened in step 3. Pull the skids out from under the MBM. Discard or recycle them in a responsible manner.

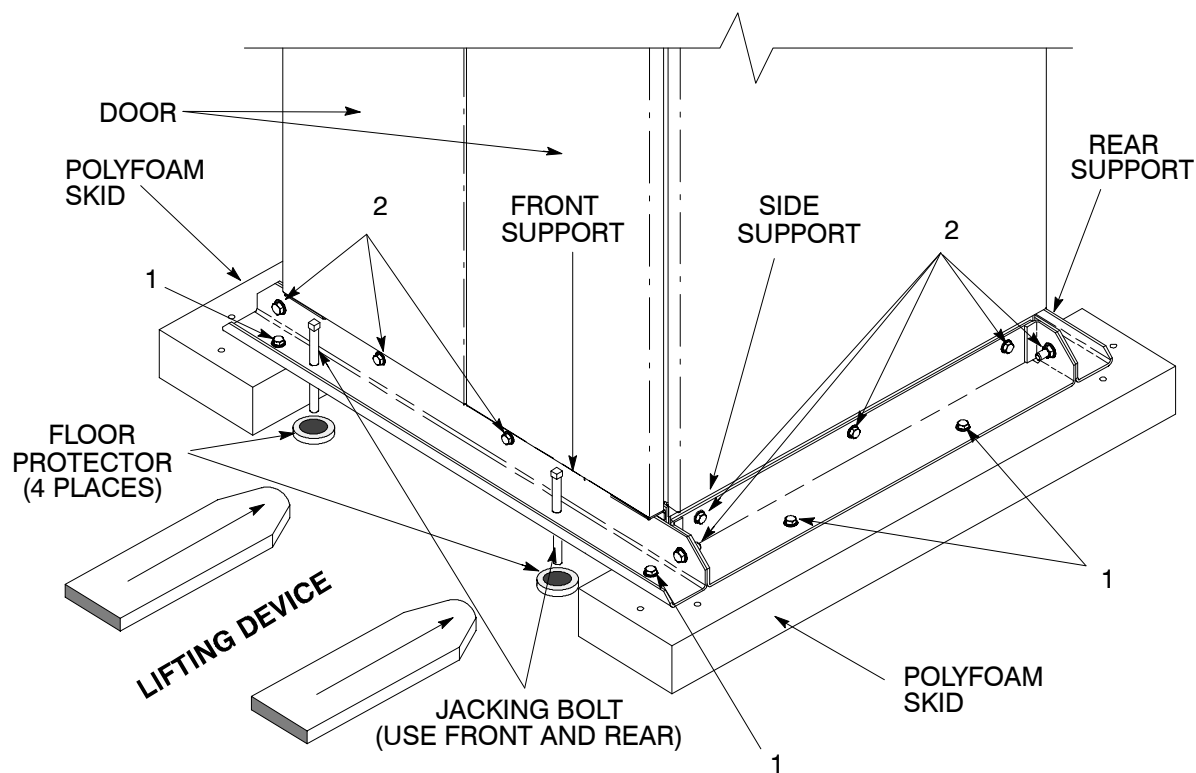

**Figure 5. Detail of Shipping Supports**

6. Carefully and evenly lower the MBM by turning each jacking bolt counterclockwise in sequence no more than two full turns each (maximum) until the supports contact the floor, and the module is no longer supported by the jacking bolts.
7. When the module is resting on the floor, remove the jacking bolts. Discard or recycle them in a responsible manner.
8. Remove the hardware labeled “2” in Figure 5, holding the front, rear and side supports to the module base (14 places). Discard or recycle the hardware and support brackets in a responsible manner.
9. Install the doors removed in step 1. The MBM is now ready to be rolled to its final location.

# 3

## Installing and Wiring the Maintenance Bypass Module

When the maintenance bypass module (MBM) has been moved to its installed location, unpacked, and inspected, it is ready for installation. This section discusses the typical process of installing the MBM in the free-standing situation. The MBM is shown in Figures 6 and 7.

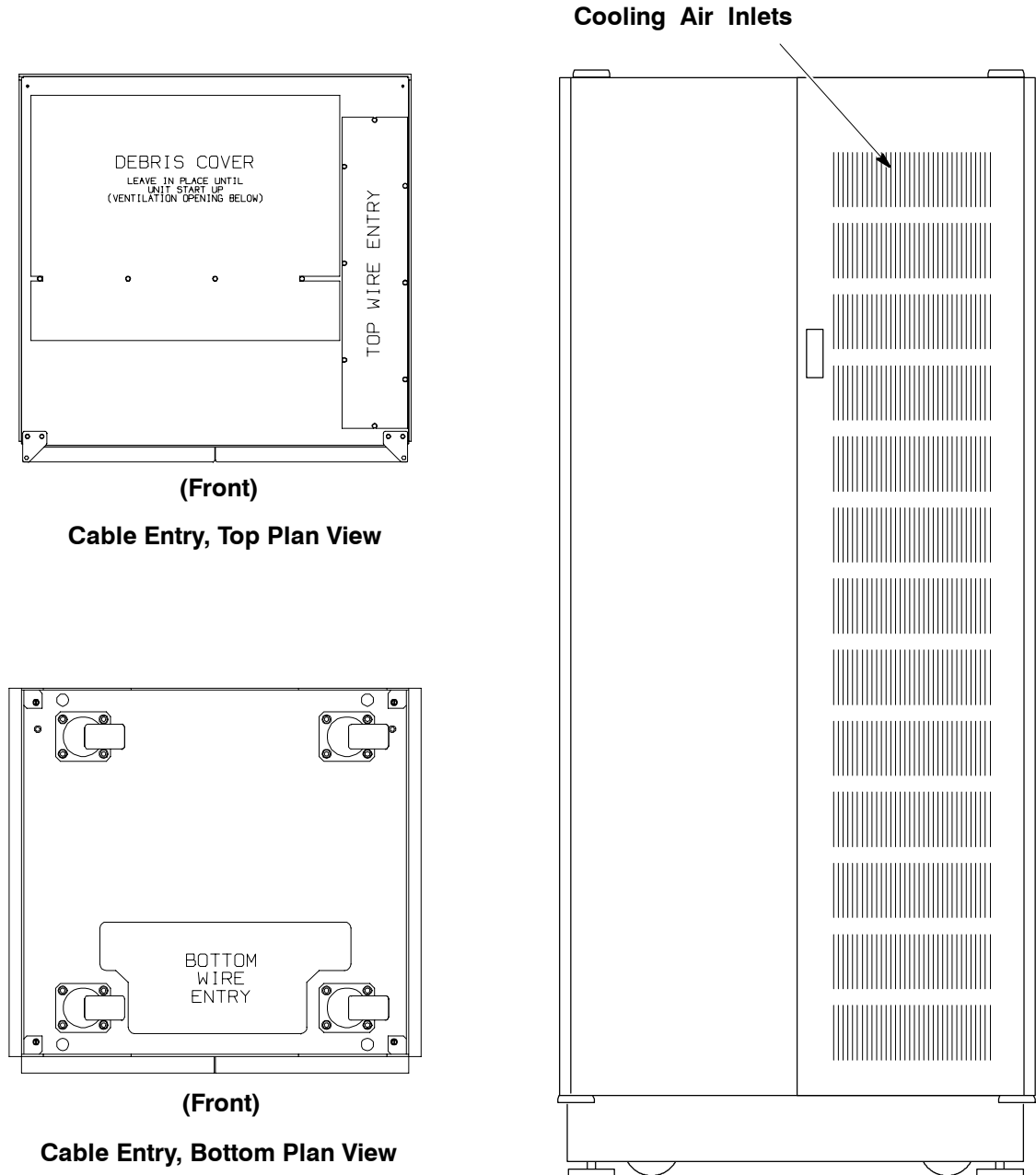

**Figure 6. Top, Bottom, and Front View of Maintenance Bypass Module (200 kVA–500kVA w/o XFMR)**

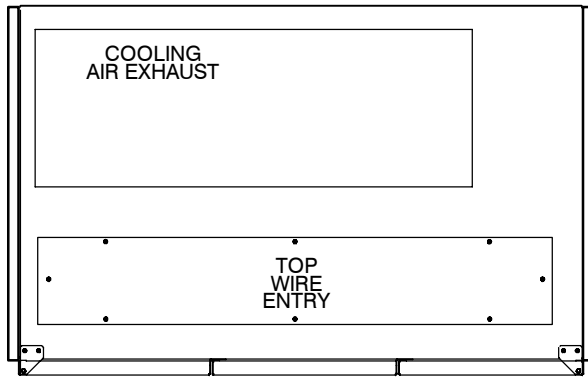

FRONT  
*Cable Entry  
 Top Plan View*

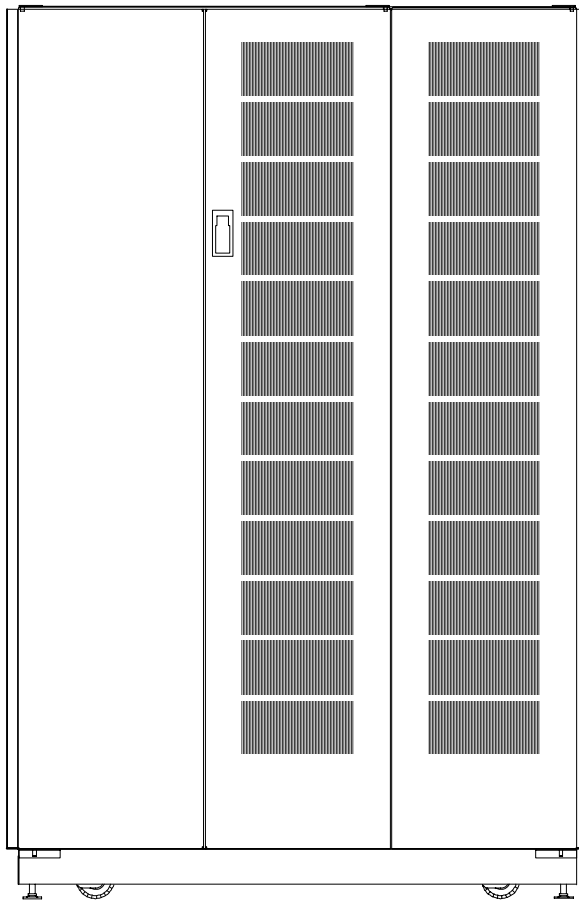

*No Cable Entry  
 Bottom Plan View*

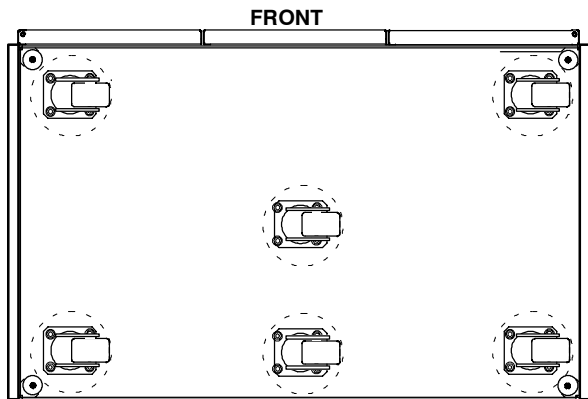

**Figure 7. Top, Bottom, and Front View of Maintenance Bypass Module with Auto/Isolation Transformer for Powerware (225 kVA-500 kVA) UPS**



Refer to the following while installing the MBM:

- Dimensions in this manual are in millimeters and (inches).
- Do not tilt the unit more than  $\pm 10^\circ$  during installation.
- Remove the conduit landing plates to add conduit landing holes as required. Plate material is 16 gauge steel (0.06 in. thick).
- Terminals are UL and CSA rated at  $90^\circ\text{C}$ . A hex key tool is required to attach wires to the terminals.
- Details about power wiring are provided in Tables A through H of Appendix A of this manual.

Figure 8 shows typical power wiring terminations of the UPS module and Maintenance Bypass Module without Auto/Isolation transformer (Powerware 9315 200 kVA–500 kVA). Refer to the Powerware 9315 Installation manual provided with the UPS system for location of UPS module cabinet wiring terminations.

**NOTE:** Material and labor for external wiring are to be provided by designated personnel.

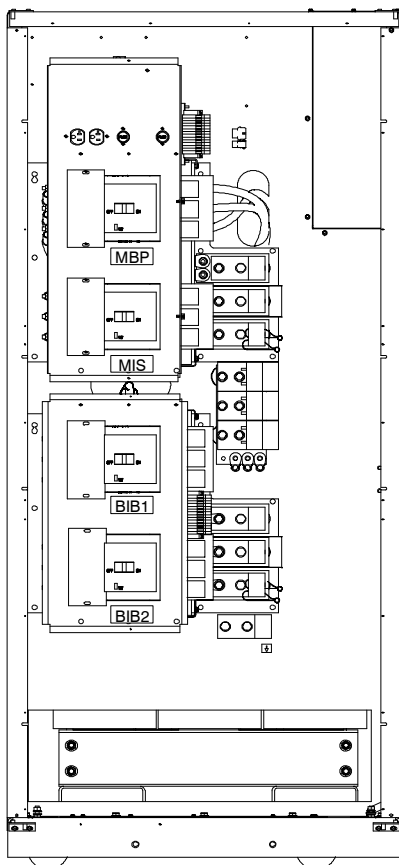

Maintenance Bypass Module  
Door Removed for Clarity  
See Appendix A Dwg 164201233-19

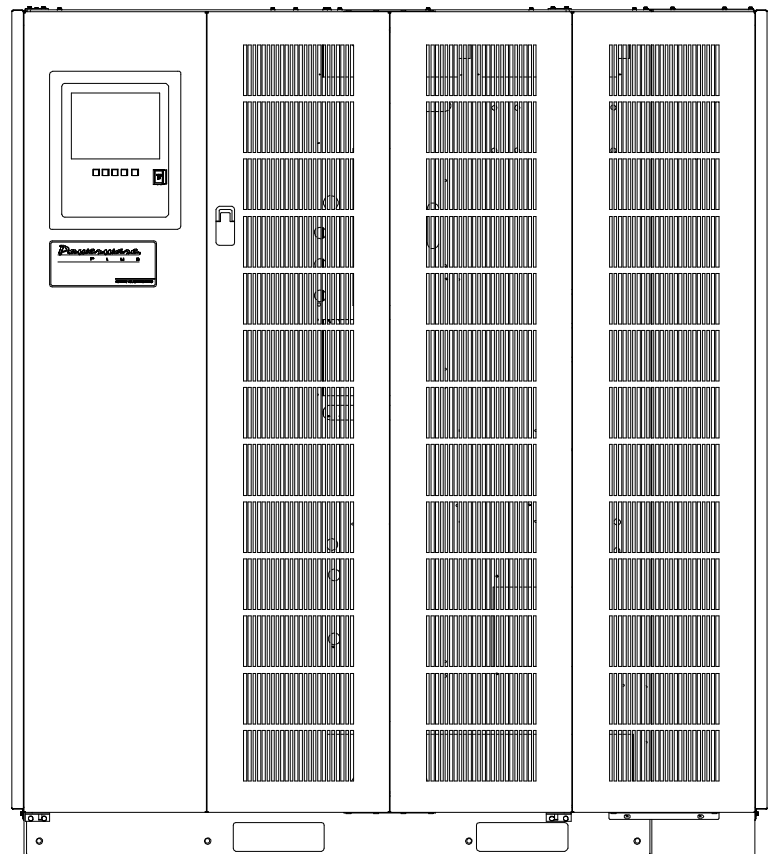

200-500 UPS MODULE

**Figure 8. Typical Power Wiring Terminations of UPS Module and Maintenance Bypass Module without Auto/Isolation Transformer (200 kVA–500 kVA)**

The recommended location, for the Maintenance Bypass Module, is as close to the installed UPS module as possible. Refer to Table A through E of Appendix A for wire rating and sizing information

The MBM is packaged in a module similar to the UPS modules (same height, width, depth). The MBM is designed as a standard stand-alone configuration and conduit runs are required.

**Remote connection (cables, lugs, and hardware supplied by others)**

- All cables are terminated to MBM mechanical pressure lugs.

## **Line and Load Wiring**

---

The Maintenance Bypass Module provides a means to manually transfer the Critical load from the UPS module via the UPS Module Bypass to a Maintenance Bypass Module as may be necessary for shutting down the UPS Module for maintenance or testing. The proper operation of the transfer is accomplished without interrupting the load power.

The UPS Module Bypass AC Input and the Maintenance Bypass AC Input must be from the same or synchronized AC sources. The UPS Module Bypass Input is connected through the MBM cabinet via an optional Bypass Input Breaker (BIB), if installed. The Maintenance Bypass Breaker (MBP) is placed in the primary of the stepdown transformer (MBM 300, 480:208VAC or 600:208VAC) or secondary of the stepdown transformer (MBM 225, 480:208VAC) or connected directly to the Maintenance Bypass source if the Auto/Isolation Transformer is not required.

UPS Module AC output connects through the MBM cabinet via isolation breaker MIS. Critical Load terminals are located on the load side of breakers MBP and MIS or secondary of the transformer (refer to oneline drawing detail).

The Critical Load may be transferred in a Make-Before-Break transfer sequence between the UPS Bypass Source and the Maintenance Bypass source after UPS output has been transferred from the UPS module to the UPS bypass operating mode. The MBP must first be closed to prevent power interruption and MIS opened to provide UPS isolation from the Critical Load bus. Refer to the Transfer Sequence label affixed to the front of the MBM cabinet.

# 4

## Maintenance Bypass Module Operation

This chapter provides preliminary checks, maintenance operations and a schematic diagram of the maintenance bypass module.

### Preliminary Checks and Startup for UPS Equipped with Maintenance Bypass Module (MBM)

---

Installation inspection and startup procedures must be performed only by an Powerware Corporation authorized service person. The procedure is normally part of the sales contract for the UPS system.

**WARNING:**

**Attempts to startup the UPS system yourself may damage equipment and/or your critical load. Such attempts may also invalidate your system warranty.**

### Maintenance Bypass Module Operation

---

The MBM is provided for use with the Powerware 9315 (200 kVA–500kVA) UPS module.

**WARNING:**

**Only persons familiar with the operation of this equipment should transfer loads. Failure to follow the transfer sequence exactly may cause loss of power to the critical load or may cause overload protection devices to function.**

**Operator Note:**

**MIS is to be OPENED *only* after MBP is CLOSED**

**MBP is to be OPENED *only* after MIS is CLOSED**

## MBM Operation Without Kirk Key Interlocks

---

The following transfer sequence is the recommended procedure for the step-by-step load transfer from and back to the UPS when required. This information is provided on a label located on the deadfront panel behind the right front door of the MBM.

### From UPS Bypass to Maintenance Bypass:

1. Confirm BIBs, if installed, are closed.
2. Transfer UPS from Normal to Bypass mode (see UPS Operation manual).  
*NOTE: For Parallel Redundant systems, transfer both UPS modules to Bypass mode.*
3. Close MBP breaker.

**CAUTION:**  
Failure to close MBP breaker results in loss of power to the critical load.

4. Open MIS breaker.
5. Deenergize UPS before servicing unit (see UPS operation manual).

**CAUTION:**  
For UPS electrical isolation, BIB breaker (if applicable) must be opened.

### From Maintenance Bypass to UPS Bypass:

1. Confirm BIBs, if installed, are closed.
2. Transfer UPS from Normal to Bypass mode (see UPS Operation manual).  
*NOTE: For Parallel Redundant systems, transfer both UPS modules to Bypass mode.*
3. Close MIS breaker.

**CAUTION:**  
Failure to close MIS breaker results in loss of power to the critical load.

4. Open MBP breaker.
5. To place UPS in Normal Mode, see UPS operation manual.

**NOTE:** While the UPS is in Normal Mode and the MIS breaker is closed, the MBP breaker always trips OFF. Likewise, while the UPS is in Normal Mode and the MBP is closed, the MIS breaker always trips OFF.

## **MBM Operation With Kirk Key Interlocks (Optional)**

---

The following transfer sequence is the recommended procedure for the step-by-step load transfer from and back to the UPS when required. This information is provided on a label located on the deadfront panel behind the right front door of the MBM.

### **Kirk Key Solenoid Release Unit (SKRU)**

The 120VAC operating power for the Kirk Key Solenoid Release Unit (SKRU) is derived from the Maintenance Bypass source.

The Kirk Key SKRU is provided to prevent access to the key, which is necessary to initiate the transfer sequence. The operator must observe the instructions on the Transfer Sequence nameplate mounted on the MBP Panelboard.

Electrical interlocks inhibit key release until UPS is in the Bypass mode.

### **MBM Transfer Sequences**

#### **From UPS Bypass to Maintenance Bypass:**

1. Confirm BIBs, if installed, are closed.
2. Transfer UPS from Normal to Bypass mode (see UPS Operation manual).  
*NOTE: For Parallel Redundant systems, transfer both UPS modules to Bypass mode.*
3. Depress pushbutton on the solenoid key release unit (SKRU). Turn and remove key "A". Key "A" may be removed when UPS system is in Bypass mode as indicated by illuminated pilot light.
4. Insert key "A" into MBP lock, retract bolt, close MBP breaker. Remove key "B".

**CAUTION:**  
**Failure to close MBP breaker results in loss of power to the critical load.**

5. Insert key "B" into MIS lock, open MIS breaker, extend bolt. Remove key "A".
6. Insert key "A" into solenoid and turn key to LOCK position.
7. Deenergize UPS before servicing (see UPS Operation manual).

**CAUTION:**  
**For UPS electrical isolation, BIB breaker (if applicable) must be opened.**

## From Maintenance Bypass to UPS Bypass:

1. Confirm BIBs, if installed, are closed.
2. Transfer UPS to Bypass mode (see UPS Operation manual).  
*NOTE: For Parallel Redundant systems, transfer both UPS modules to Bypass mode.*
3. Depress pushbutton on the Solenoid Key Release Unit (SKRU). Turn and remove key "A".
4. Insert key "A" into MIS lock, retract bolt, close MIS breaker. Remove key "B".

**CAUTION:**  
**Failure to close MIS breaker results in loss of power to the critical load.**

5. Insert key "B" into MBP lock, open MBP breaker, extend bolt. Remove key "A".
6. Insert key "A" into solenoid and turn key to LOCK position.
7. See UPS Operation manual to place UPS in Normal mode.

**WARNING:**  
**Dangerous and potentially lethal voltages are present within the UPS enclosure. When maintenance or repair activities are to be performed, the UPS and the UPS Bypass power sources should be deenergized and verified with a meter before working in the required area.**

**WARNING:**  
**UPS equipment has power feeds that are derived from two or more power sources.**

## Maintenance

---

Maintenance should be scheduled on a periodic basis, recommended not to exceed one year. More frequent intervals are recommended if the equipment is subjected to highly repetitive operations.

**CAUTION:**  
Refer to Section 9 – *Maintaining the UPS System* of the applicable Powerware 9315 Operation manual, before beginning maintenance or repairs on the UPS equipment.

**WARNING:**  
Dangerous and life-threatening voltages are present when the UPS is operating. De-energize all equipment before physically touching potentially live parts.

Periodic inspections of the maintenance bypass module should be made to determine if components, wiring, and connections exhibit evidence of overheating. Particular attention should be given to bolted connections. Maintenance procedures should specify that the bolted connections be retorqued to values listed on labels posted on the equipment.

**CAUTION:**  
Overtightening of bolted connections containing compression washers decreases the washer's ability to maintain compression during heating and cooling cycles.

Refer to circuit breaker manufacturer's application and maintenance literature for recommended maintenance practices and procedures.

## Short Circuits

---

Short circuits are not considered normal phenomena in UPS applications. Tripping of protective devices due to low impedance short circuits should be thoroughly investigated for damage to conductors, insulation, and the protective devices in accordance with the manufacturer's recommendations.

## Maintenance Bypass Module Diagrams

---

See Appendix A for online drawings and system configuration schematics

**This Page Intentionally Left Blank.**



# Appendix A – Customer Information

The information in this appendix will help you plan for and install your Maintenance Bypass Module cabinet. This appendix contains the following:

- 164201233–1 Typical UPS System with MBM Cabinet
- 164201233–2 Installation Notes – Table A
- 164201233–3 Oneline – MBM225 (225kVA), RT, 208:208VAC
- 164201233–4 Oneline – MBM225 (225kVA), Parallel, 208:208VAC
- 164201233–5 Installation Notes – Table B
- NO TAG Installation Notes – Table C
- 164201233–7 Oneline – MBM300 (200–300kVA) and MBM500 (400–500kVA) RT, 380:380VAC, 400:400VAC, 415:415VAC, 480:480VAC, 600:600VAC
- 164201233–8 Oneline – MBM300 (200–300kVA) Parallel, 380:380VAC, 400:400VAC, 415:415VAC, 480:480VAC, 600:600VAC
- 164201233–9 Installation Notes – Table D
- 164201233–10 Oneline – MBM225 (225kVA), RT, 480:208VAC
- 164201233–11 Oneline – MBM225 (225kVA), Parallel, 480:208VAC
- 164201233–12 Installation Notes – Table E
- 164201233–13 Oneline – MBM300 (225–300kVA) RT, 480:208VAC, 600:208VAC
- 164201233–14 Oneline – MBM300 (225–300kVA) Parallel, 480:208VAC, 600:208VAC
- 164201233–15 Installation Notes – Table F
- 164201233–16 Installation Notes – Table G
- 164201233–17 Installation Notes – Table H
- 164201233–18 Installation Notes – Table I
- 164201233–19 Typical MBM Cabinet – 200-300kVA w/o XFMR
- 164201233–20 MBM225 and MBM300 Cabinet with Auto/Isolation Transformer

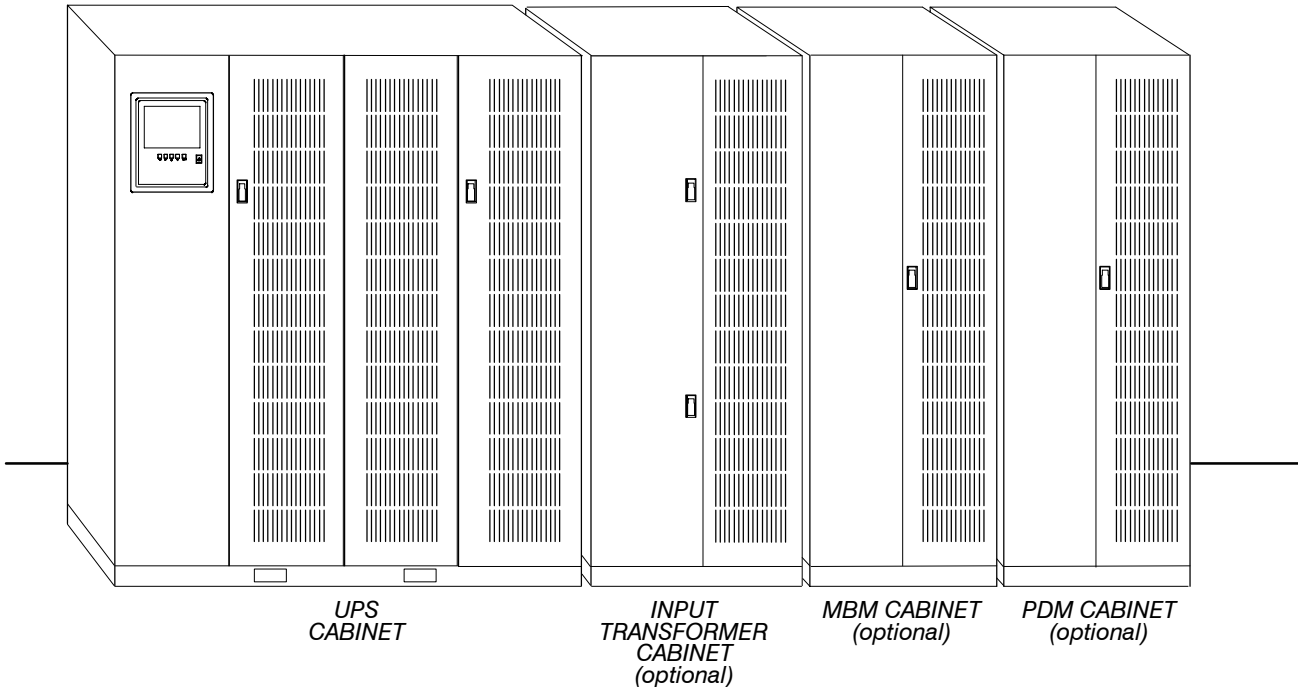

**200-500kVA UPS System with MBM**

DESCRIPTION:		<b>TYPICAL UPS SYSTEM WITH MBM CABINET</b>	
DRAWING NO:	164201233-1	SHEET:	1 of 1

<b>Table A. Ratings &amp; External Wiring Requirements for MBM225 (225kVA), 208:208VAC</b>			
<b>Rating and External Wiring Requirement</b>		<b>Units</b>	<b>Rating 60 Hz</b>
<b>Basic unit rating at 0.8 lagging PF load</b>		KVA	225
		KW	180
UPS Input Voltage/Bypass Input		VOLTS	208
UPS Output Voltage		VOLTS	208
<b>A</b>	AC Input to Maintenance Bypass (3) Phases, (1) Neutral, (1) Ground	AMPS	625
	Conductor Size Number per Phase	AWG/MCM (each)	400 (3)
<b>B</b>	AC Input to UPS Bypass (3) Phases, (1) Ground	AMPS	625
	Conductor Size Number per Phase	AWG/MCM (each)	400 (3)
<b>C</b>	AC Output to Critical Load (3) Phases, (1) Neutral, (1) Ground	AMPS	625
	Conductor Size Number per Phase	AWG/MCM (each)	400 (3)
<b>D</b>	UPS/PTC Output to MBM Cabinet (MIS) (3) Phases, (1) Neutral, (1) Ground	AMPS	625
	Conductor Size Number per Phase	AWG/MCM (each)	400 (3)
<b>E</b>	Control Wiring to UPS (2) Conductors	VOLTS AMPS	120 1

Note: Callout letters **A, B, C, D,** and **E** map to drawing 164201233-3 (Reverse Transfer Connection) and 164201233-4 (Parallel Connection). Read and understand the notes on these drawings while planning your installation.

<i>DESCRIPTION:</i>		
<b>INSTALLATION NOTES – TABLE A</b>		
<i>DRAWING NO:</i>	164201233-2	<i>SHEET:</i> 1 of 1

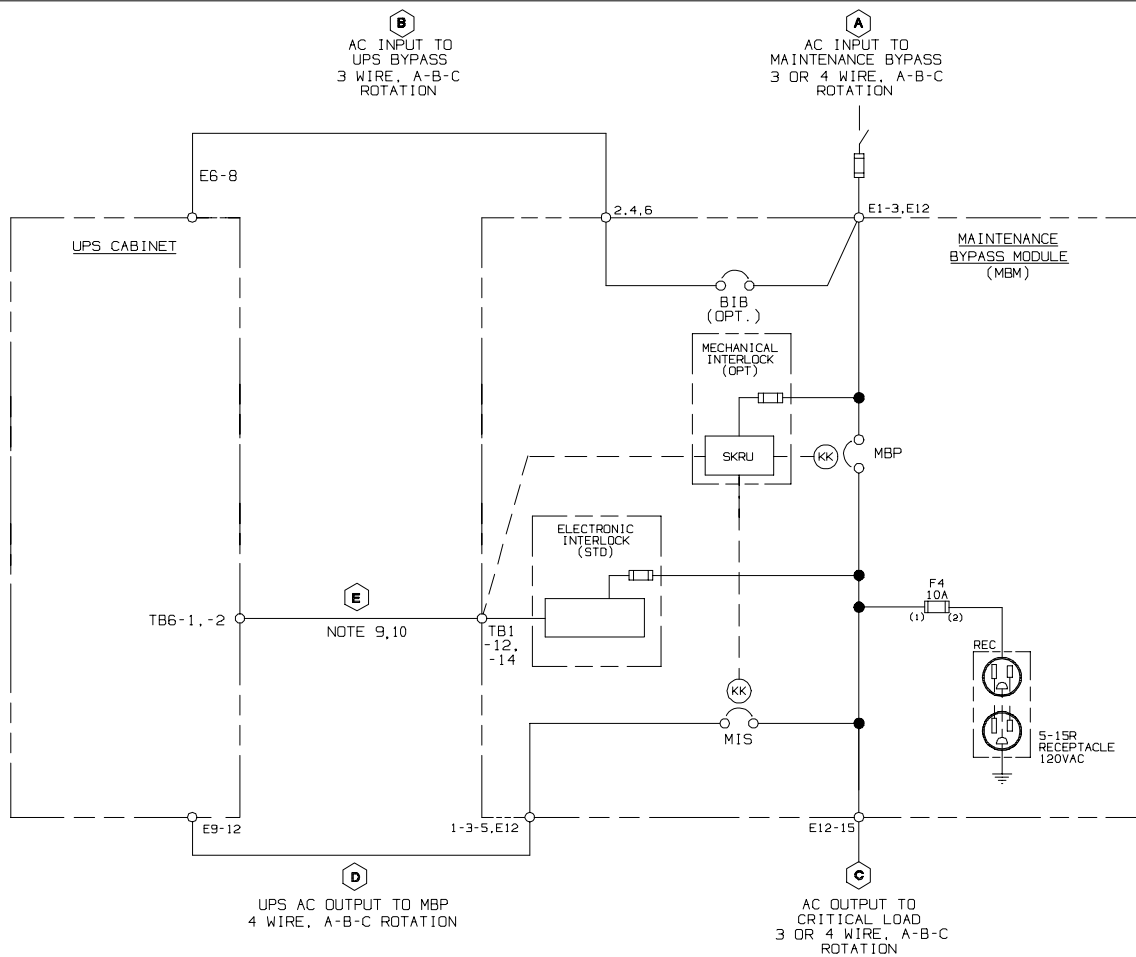

Read and understand the following notes while planning your installation:

1. Refer to national and local electric codes for acceptable external wiring practices.
2. Material and labor for external wiring requirements are to be provided by others.
3. For external wiring requirement, including the minimum AWG size of external wiring, see the appropriate column in Table A. The power wiring for this equipment is rated at 90 degrees Celsius.
4. The output of the UPS is not a separately derived source. The output neutral shall not be bonded to equipment ground in the MBM cabinet. Refer to NEC and local codes for proper grounding practices.
5. The maintenance bypass (MBM) source must contain overcurrent protection with the maximum trip setting of 125% of the full load input current in Table A.
6. The bypass feed into this equipment utilizes either three or four wires. The rectifier feed into this equipment utilizes three wires. However, the phases must be symmetrical about ground (i.e., from a Wye source) for proper equipment operation. Failure to follow these instructions will void the product warranty..
7. Transfer sequence instructions for the MBM are placed on the breaker access panel behind the cabinet doors.
8. Control wiring must be installed in separate conduit from the power wiring.
9. Electronic interlock is a standard part of the maintenance bypass module cabinet. This electronic interlock can be replaced with an optional (extra cost) mechanical interlock if required.
10. Refer to Table H-1 for control wiring connections.
11. A Maintenance Bypass neutral feeder must be supplied when the MBM output neutral is used. If no Maintenance Bypass neutral is supplied, the MBM output neutral is not to be used. Install a bonding jumper between neutral (from UPM output) and ground at the MBM, when no bypass feeder neutral is present. In neither case shall the UPM output neutral be bonded to ground.

**LEGEND**

- MIS: MAINTENANCE ISOLATION BREAKER  
 MBP: MAINTENANCE BYPASS BREAKER  
 BIB: BYPASS INPUT BREAKER  
 SKRU: SOLENOID KEY RELEASE UNIT (MECHANICAL INTERLOCK)  
 RT: REVERSE TRANSFER

DESCRIPTION:	<b>ONLINE – MBM225 (225kVA), RT, 208:208VAC</b>	
DRAWING NO:	164201233–3	SHEET: 1 of 1

110100058 D2

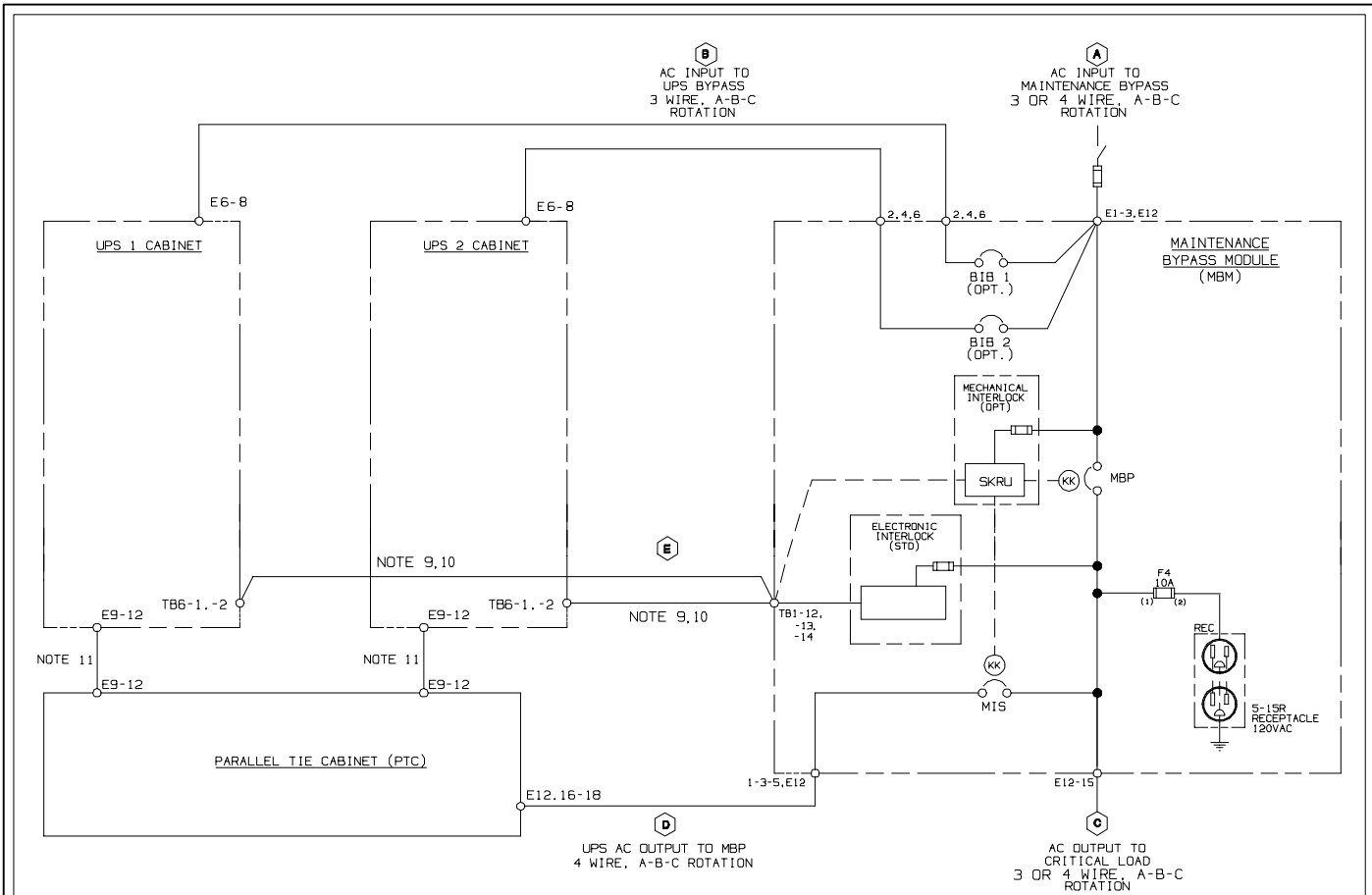

Read and understand the following notes while planning your installation:

1. Refer to national and local electric codes for acceptable external wiring practices.
2. Material and labor for external wiring requirements are to be provided by others.
3. For external wiring requirement, including the minimum AWG size of external wiring, see the appropriate column in Table A. The power wiring for this equipment is rated at 90 degrees Celsius.
4. The output of the UPS is not a separately derived source. The output neutral shall not be bonded to equipment ground in the MBM cabinet. Refer to NEC and local codes for proper grounding practices.
5. The maintenance bypass (MBM) source must contain overcurrent protection with the maximum trip setting of 125% of the full load input current in Table A.
6. The bypass feed into this equipment utilizes either three or four wires. The rectifier feed into this equipment utilizes three wires. However, the phases must be symmetrical about ground (i.e., from a Wye source) for proper equipment operation. Failure to follow these instructions will void the product warranty.
7. Transfer sequence instructions for the MBM are placed on the breaker access panel behind the cabinet doors.
8. Control wiring must be installed in separate conduit from the power wiring.
9. Electronic interlock is a standard part of the maintenance bypass module cabinet. This electronic interlock can be replaced with an optional (extra cost) mechanical interlock if required.
10. Refer to Table H-2 for control wiring connections.
11. Refer to Parallel Redundant System Manual for details.
11. A Maintenance Bypass neutral feeder must be supplied when the MBM output neutral is used. If no Maintenance Bypass neutral is supplied, the MBM output neutral is not to be used. Install a bonding jumper between neutral (from UPM output) and ground at the MBM, when no bypass feeder neutral is present. In neither case shall the UPM output neutral be bonded to ground.

**LEGEND**

- MIS: MAINTENANCE ISOLATION BREAKER  
 MBP: MAINTENANCE BYPASS BREAKER  
 BIB: BYPASS INPUT BREAKER  
 SKRU: SOLENOID KEY RELEASE UNIT (MECHANICAL INTERLOCK)  
 PTC: PARALLEL TIE CABINET  
 RT: REVERSE TRANSFER

110100072

<b>DESCRIPTION:</b>	<b>ONLINE – MBM225 (225kVA), PARALLEL, 208:208VAC</b>	
<b>DRAWING NO:</b>	<b>164201233-4</b>	<b>SHEET:</b> 1 of 1

**Table B. Rating and External Wiring Requirements for  
MBM300 (200 and 250kVA)  
380/400/415:380/400/415VAC**

RATING AND EXTERNAL WIRING REQUIREMENT		UNITS	RATING 60 HZ	
<b>BASIC UNIT RATING AT 0.8 LAGGING PF LOAD</b>		<b>KVA KW</b>	<b>250 200</b>	<b>200 160</b>
<b>UPS INPUT VOLTAGE BYPASS INPUT/UPS OUTPUT VOLTAGE</b>		<b>VOLTS VOLTS</b>	<b>380/400/415 380/400/415</b>	<b>380/400/415 380/400/415</b>
<b>A</b>	AC INPUT TO MAINTENANCE BYPASS (3) PHASES, (1) GROUND	AMPS	360	290
	CONDUCTOR SIZE NUMBER PER PHASE	AWG/MCM (each)	250 (2)	250 (2)
<b>B</b>	AC INPUT TO UPS BYPASS (3) PHASES, (1) GROUND	AMPS	360	290
	CONDUCTOR SIZE NUMBER PER PHASE	AWG/MCM (each)	250 (2)	250 (2)
<b>C</b>	AC OUTPUT TO CRITICAL LOAD (3) PHASES, (1) NEUTRAL, (1) GROUND	AMPS	360	290
	CONDUCTOR SIZE NUMBER PER PHASE	AWG/MCM (each)	250 (2)	250 (2)
<b>D</b>	UPS/PTC OUTPUT TO MBM CABINET (MIS) (3) PHASE, (1) NEUTRAL, (1) GROUND	AMPS	360	290
	CONDUCTOR SIZE NUMBER PER PHASE	AWG/MCM (each)	250 (2)	250 (2)
<b>E</b>	CONTROL WIRING TO UPS	VOLTS	120	120
	(2) CONDUCTORS	AMPS	1	1

Note: Callout letters **A, B, C, D,** and **E** map to drawing 164201233-7 (Reverse Transfer Connection) and 164201233-8 (Parallel Connection). Read and understand the notes on these drawings while planning your installation.

DESCRIPTION:

**INSTALLATION NOTES – TABLE B**

DRAWING NO:

164201233-5

SHEET:

1 of 1

**Table C. Ratings & External Wiring Requirements for  
MBM300 (225 & 300kVA) & MBM500 (400 & 500kVA),  
480:480VAC/600:600VAC**

Rating and External Wiring Requirement		Units	Rating 60 Hz					
Basic unit rating at 0.8 lagging PF load		KVA KW	500 400	400 320	300 240	225 180		
UPS Input Voltage		VOLTS	480	480	480	600	480	600
Bypass Input/UPS Output Voltage		VOLTS	480	480	480	600	480	600
<b>A</b>	AC Input to Maintenance Bypass (3) Phases, (1) Ground	AMPS	600	481	360	288	271	217
	Conductor Size Number per Phase	AWG/MCM (each)	350 (3)	350 (3)	250 (2)	250 (2)	250 (2)	250 (2)
<b>B</b>	AC Input to UPS Bypass (3) Phases, (1) Ground	AMPS	600	481	360	288	271	217
	Conductor Size Number per Phase	AWG/MCM (each)	350 (3)	350 (3)	250 (2)	250 (2)	250 (2)	250 (2)
<b>C</b>	AC Output to Critical Load (3) Phases, (1) Neutral, (1) Ground	AMPS	600	481	360	288	271	217
	Conductor Size Number per Phase	AWG/MCM (each)	350 (3)	350 (3)	250 (2)	250 (2)	250 (2)	250 (2)
<b>D</b>	UPS/PTC Output to MBM Cabinet (MIS) (3) Phases, (1) Neutral, (1) Ground	AMPS	600	481	360	288	271	217
	Conductor Size Number per Phase	AWG/MCM (each)	350 (3)	350 (3)	250 (2)	250 (2)	250 (2)	250 (2)
<b>E</b>	Control Wiring to UPS (2) Conductors	VOLTS	120	120	120	120	120	120
		AMPS	1	1	1	1	1	1

Note: Callout letters **A, B, C, D,** and **E** map to drawing 164201233-7 (Reverse Transfer Connection) and 164201233-8 (Parallel Connection). Read and understand the notes on these drawings while planning your installation.

DESCRIPTION:

**INSTALLATION NOTES – TABLE C**

DRAWING NO:

164201233-6

SHEET:

1 of 1

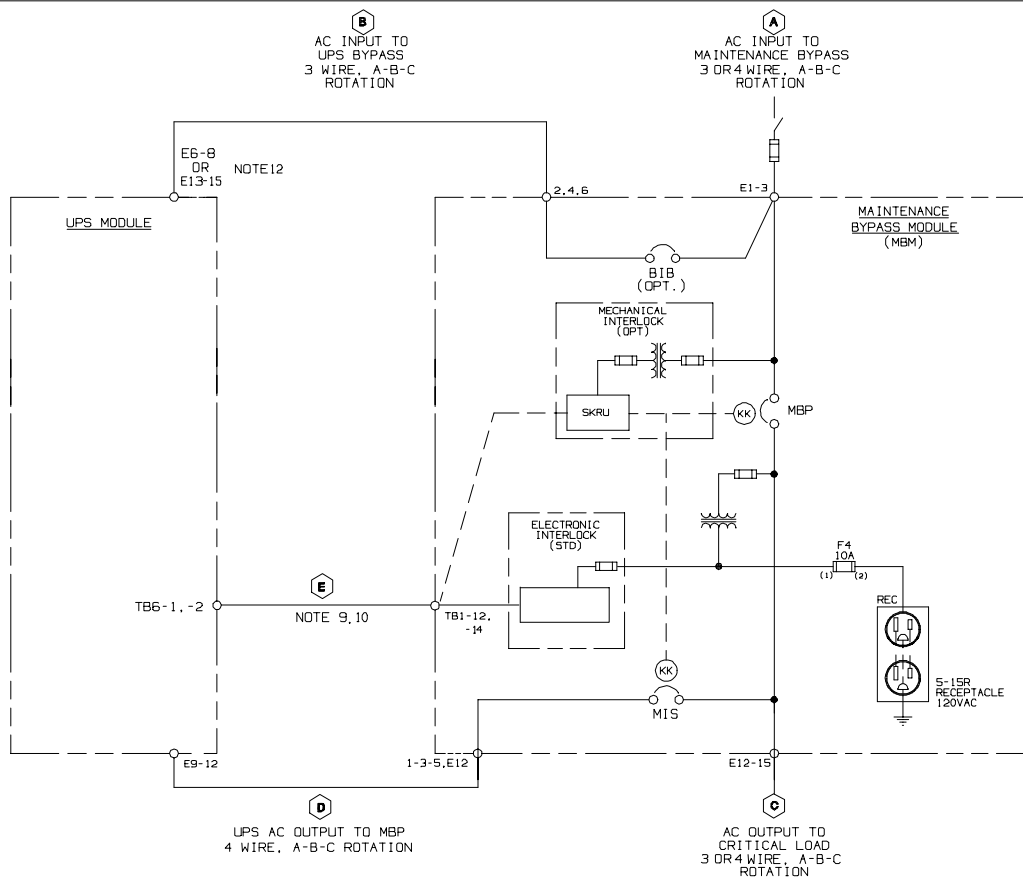

Read and understand the following notes while planning your installation:

1. Refer to national and local electric codes for acceptable external wiring practices.
2. Material and labor for external wiring requirements are to be provided by others.
3. For external wiring requirement, including the minimum AWG size of external wiring, see the appropriate column in Table B or C. The power wiring for this equipment is rated at 90 degrees Celsius.
4. The output of the UPS is not a separately derived source. The output neutral shall not be bonded to equipment ground in the MBM cabinet. Refer to NEC and local codes for proper grounding practices.
5. The maintenance bypass (MBM) source must contain overcurrent protection with the maximum trip setting of 125% of the full load input current in Table B or C.
6. The bypass feed into this equipment utilizes either three or four wires. The rectifier feed into this equipment utilizes three wires. However, the phases must be symmetrical about ground (i.e., from a Wye source) for proper equipment operation. Failure to follow these instructions will void the product warranty..
7. Transfer sequence instructions for the MBM are placed on the breaker access panel behind the cabinet doors.
8. Control wiring must be installed in separate conduit from the power wiring.
9. Electronic interlock is a standard part of the maintenance bypass module cabinet. This electronic interlock can be replaced with an optional (extra cost) mechanical interlock if required.
10. Refer to Table H-1 for control wiring connections.
11. A Maintenance Bypass neutral feeder must be supplied when the MBM output neutral is used. If no Maintenance Bypass neutral is supplied, the MBM output neutral is not to be used. Install a bonding jumper between neutral (from UPM output) and ground at the MBM, when no bypass feeder neutral is present. In neither case shall the UPM output neutral be bonded to ground.
12. Refer to UPS installation manual for proper bypass terminating lug.

**LEGEND**

- MIS: MAINTENANCE ISOLATION BREAKER
- MBP: MAINTENANCE BYPASS BREAKER
- BIB: BYPASS INPUT BREAKER
- SKRU: SOLENOID KEY RELEASE UNIT (MECHANICAL INTERLOCK)
- RT: REVERSE TRANSFER

<b>DESCRIPTION: ONLINE – MBM300 (200–300kVA) AND MBM500 (400–500kVA) RT 380:380VAC, 400:400VAC, 415:415VAC, 480:480VAC, 600:600VAC</b>	
<b>DRAWING NO:</b> 164201233–7	<b>SHEET:</b> 1 of 1

11010057 D3



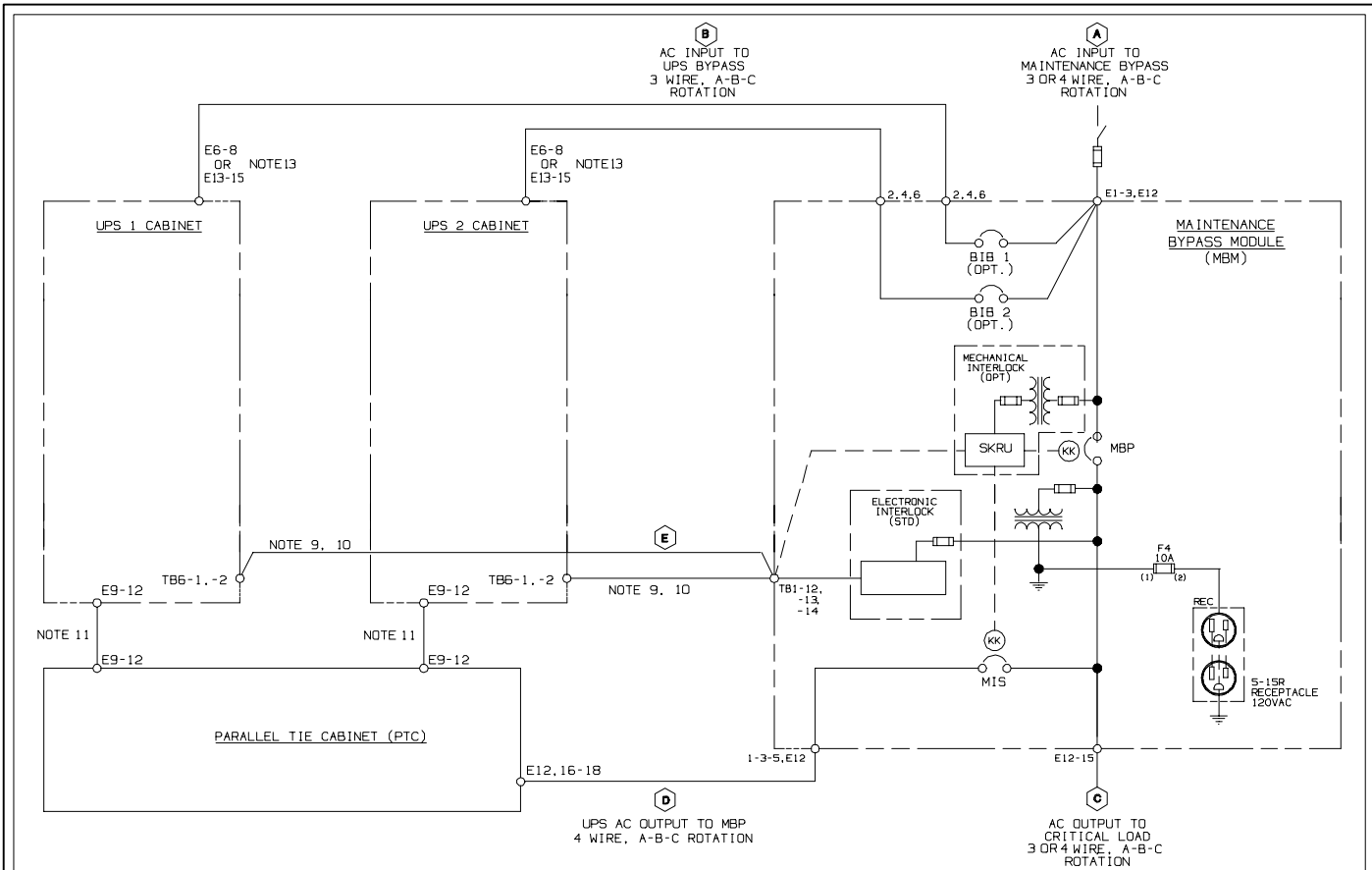

Read and understand the following notes while planning your installation:

1. Refer to national and local electric codes for acceptable external wiring practices.
2. Material and labor for external wiring requirements are to be provided by others.
3. For external wiring requirement, including the minimum AWG size of external wiring, see the appropriate column in Table B or C. The power wiring for this equipment is rated at 90 degrees Celsius.
4. The output of the UPS is not a separately derived source. The output neutral shall not be bonded to equipment ground in the MBM cabinet. Refer to NEC and local codes for proper grounding practices.
5. The maintenance bypass (MBM) source must contain overcurrent protection with the maximum trip setting of 125% of the full load input current in Table B or C.
6. The bypass feed into this equipment utilizes either three or four wires. The rectifier feed into this equipment utilizes three wires. However, the phases must be symmetrical about ground (i.e., from a Wye source) for proper equipment operation. Failure to follow these instructions will void the product warranty..
7. Transfer sequence instructions for the MBM are placed on the breaker access panel behind the cabinet doors.
8. Control wiring must be installed in separate conduit from the power wiring.
9. Electronic interlock is a standard part of the maintenance bypass module cabinet. This electronic interlock can be replaced with an optional (extra cost) mechanical interlock if required.
10. Refer to Table H-2 for control wiring connections.
11. Refer to Parallel Redundant System Manual for details.
12. A Maintenance Bypass neutral feeder must be supplied when the MBM output neutral is used. If no Maintenance Bypass neutral is supplied, the MBM output neutral is not to be used. Install a bonding jumper between neutral (from UPM output) and ground at the MBM, when no bypass feeder neutral is present. In neither case shall the UPM output neutral be bonded to ground.
13. Refer to UPS installation manual for proper bypass terminating lugs.

**LEGEND**

- MIS: MAINTENANCE ISOLATION BREAKER
- MBP: MAINTENANCE BYPASS BREAKER
- BIB: BYPASS INPUT BREAKER
- SKRU: SOLENOID KEY RELEASE UNIT (MECHANICAL INTERLOCK)
- PTC: PARALLEL TIE CABINET
- RT: REVERSE TRANSFER

110100069

**DESCRIPTION: ONELINE – MBM300 (225 & 300kVA) AND MBM500 (400–500kVA) PARALLEL 380:380VAC, 400:400VAC, 415:415VAC, 480:480VAC, 600:600VAC**

**DRAWING NO: 164201233–8**

**SHEET: 1 of 1**

<b>Table D. Rating and External Wiring Requirements for MBM225 (225KVA), 480:208VAC</b>			
<b>RATING AND EXTERNAL WIRING REQUIREMENT</b>		<b>UNITS</b>	<b>RATING 60HZ</b>
<b>BASIC UNIT RATING AT 0.8 LAGGING PF LOAD</b>		<b>KVA KW</b>	<b>225 180</b>
<b>UPS INPUT VOLTAGE BYPASS INPUT/UPS OUTPUT VOLTAGE</b>		<b>VOLTS VOLTS</b>	<b>480 208</b>
<b>A</b>	AC INPUT TO MAINTENANCE BYPASS (3) PHASES, (1) NEUTRAL, (1) GROUND (SEE NOTE)	AMPS	271
	CONDUCTOR SIZE NUMBER PER PHASE	AWG/MCM (each)	250 (2)
<b>B</b>	AC INPUT TO UPS BYPASS (3) PHASES, (1) NEUTRAL, (1) GROUND (SEE NOTE)	AMPS	625
	CONDUCTOR SIZE NUMBER PER PHASE	AWG/MCM (each)	400 (3)
<b>C</b>	AC OUTPUT TO CRITICAL LOAD (3) PHASES, (1) NEUTRAL, (1) GROUND	AMPS	625
	CONDUCTOR SIZE NUMBER PER PHASE	AWG/MCM (each)	400 (3)
<b>D</b>	UPS/PTC OUTPUT TO MBM CABINET (MIS) (3) PHASE, (1) NEUTRAL, (1) GROUND	AMPS	625
	CONDUCTOR SIZE NUMBER PER PHASE	AWG/MCM (each)	400 (3)
<b>E</b>	CONTROL WIRING TO UPS (2) CONDUCTORS	VOLTS AMPS	120 1

Note: Callout letters **A, B, C, D,** and **E** map to drawing 164201233–10 (Reverse Transfer Connection) and 164201233–11 (Parallel Connection). Read and understand the notes on these drawings while planning your installation.

<i>DESCRIPTION:</i>		
<b>INSTALLATION NOTES – TABLE D</b>		
<i>DRAWING NO:</i>	164201233–9	<i>SHEET:</i> 1 of 1

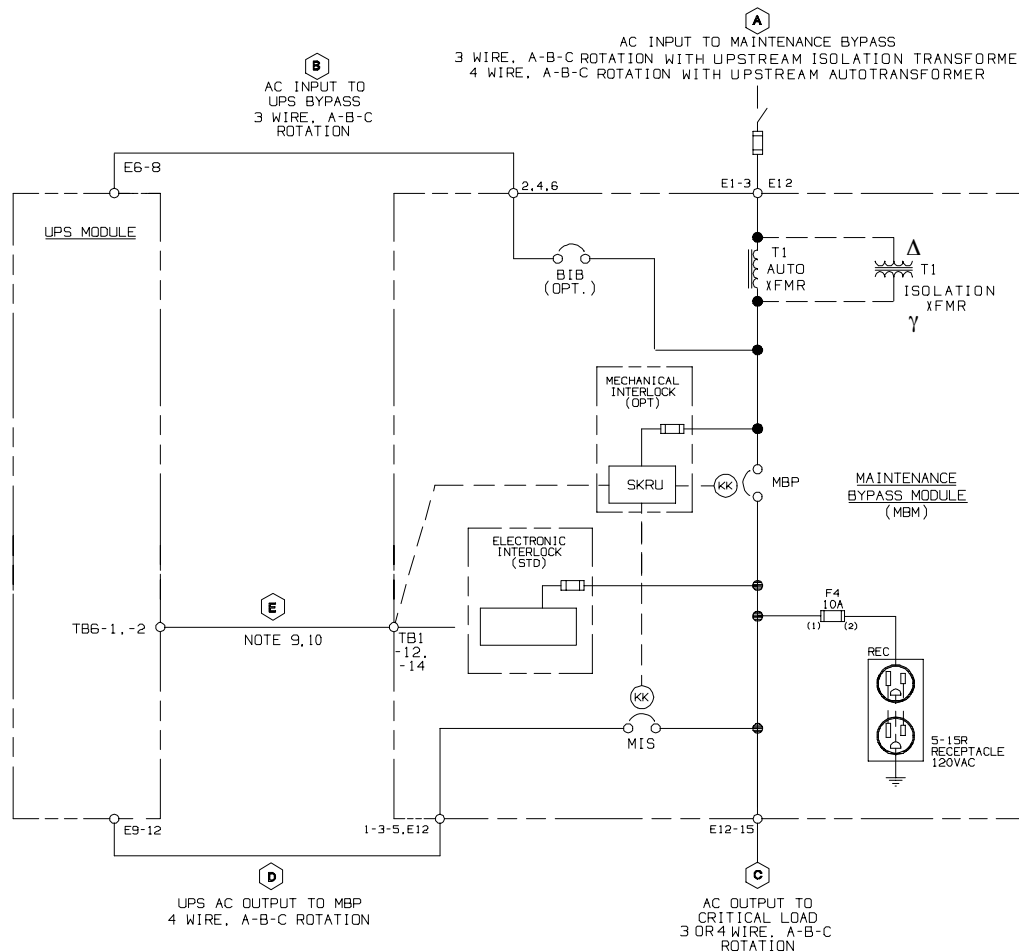

Read and understand the following notes while planning your installation:

1. Refer to national and local electric codes for acceptable external wiring practices.
2. Material and labor for external wiring requirements are to be provided by others.
3. For external wiring requirement, including the minimum AWG size of external wiring, see the appropriate column in Table D. The power wiring for this equipment is rated at 90 degrees Celsius.
4. If an AUTOTRANSFORMER is used, the output of the MBM is NOT a separately derived source. The output neutral shall NOT be bonded to equipment ground in the MBM cabinet. If an ISOLATION TRANSFORMER is used, the output of the MBM is a separately derived source. Output neutral is bonded to equipment ground through the main bonding jumper. Refer to NEC and local codes for proper grounding practices.
5. The maintenance bypass (MBM) source must contain overcurrent protection with the maximum trip setting of 125% of the full load input current in Table D.
6. The bypass feed into this equipment utilizes either three or four wires. The rectifier feed into this equipment utilizes three wires. However, the phases must be symmetrical about ground (i.e., from a Wye source) for proper equipment operation. Failure to follow these instructions will void the product warranty.
7. Transfer sequence instructions for the MBM are placed on the breaker access panel behind the cabinet doors.
8. Control wiring must be installed in separate conduit from the power wiring.
9. Electronic interlock is a standard part of the maintenance bypass cabinet. This electronic interlock can be replaced with an optional (extra cost) mechanical interlock if required.
10. Refer to Table H-1 for control wiring connections.
11. Maintenance bypass input neutral feeder must be supplied if an AUTOTRANSFORMER is used.

**LEGEND**

- MIS: MAINTENANCE ISOLATION BREAKER  
 MBP: MAINTENANCE BYPASS BREAKER  
 BIB: BYPASS INPUT BREAKER  
 SKRU: SOLENOID KEY RELEASE UNIT (MECHANICAL INTERLOCK)  
 RT: REVERSE TRANSFER  
 T1: AUTO OR ISOLATION TRANSFORMER (XFMR)

110100071

DESCRIPTION: **ONLINE – MBM225 (225kVA), RT, 480:208VAC**

DRAWING NO: 164201233–10

SHEET: 1 of 1

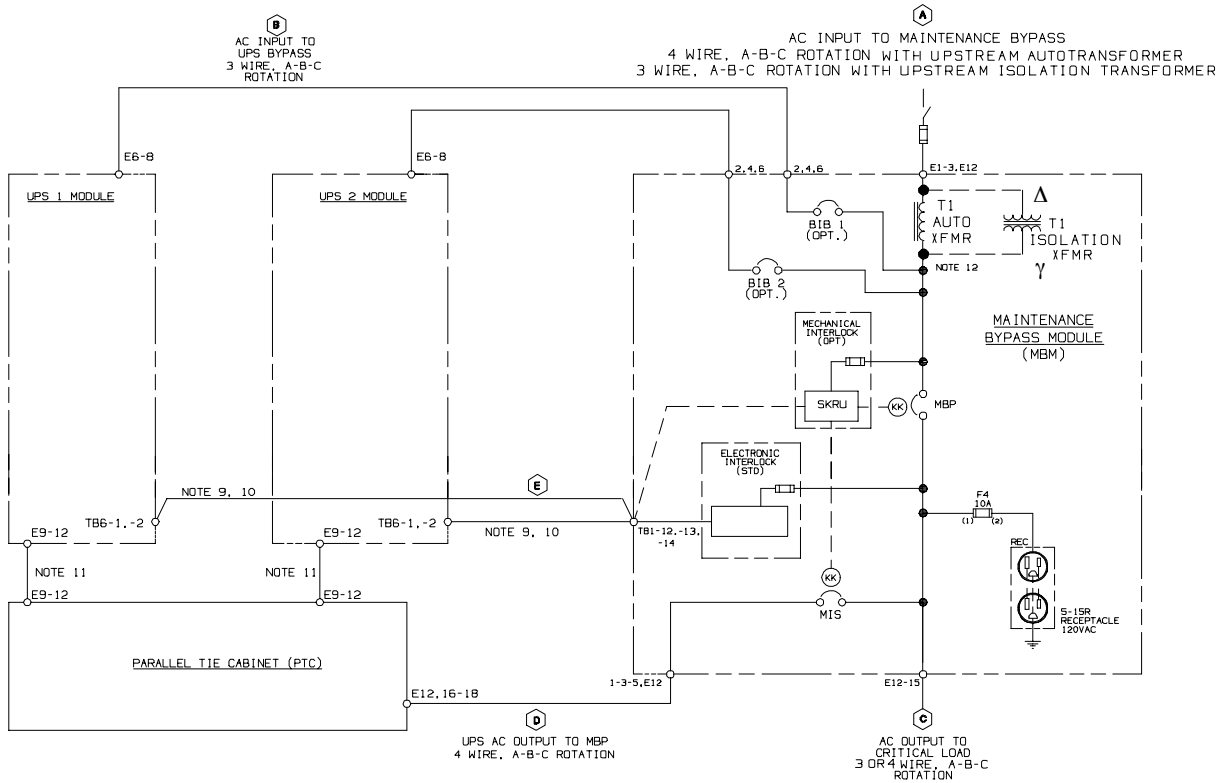

Read and understand the following notes while planning your installation:

1. Refer to national and local electric codes for acceptable external wiring practices.
2. Material and labor for external wiring requirements are to be provided by others.
3. For external wiring requirement, including the minimum AWG size of external wiring, see the appropriate column in Table D. The power wiring for this equipment is rated at 90 degrees Celsius.
4. If an AUTOTRANSFORMER is used, the output of the MBM is NOT a separately derived source. The output neutral shall NOT be bonded to equipment ground in the MBM cabinet. If an ISOLATION TRANSFORMER is used, the output of the MBM is a separately derived source. Output neutral is bonded to equipment ground through the main bonding jumper. Refer to NEC and local codes for proper grounding practices.
5. The maintenance bypass (MBM) source must contain overcurrent protection with the maximum trip setting of 125% of the full load input current in Table D.
6. The bypass feed into this equipment utilizes either three or four wires. The rectifier feed into this equipment utilizes three wires. However, the phases must be symmetrical about ground (i.e., from a Wye source) for proper equipment operation. Failure to follow these instructions will void the product warranty..
7. Transfer sequence instructions for the MBM are placed on the breaker access panel behind the cabinet doors.
8. Control wiring must be installed in separate conduit from the power wiring.
9. Electronic interlock is a standard part of the maintenance bypass module cabinet. This electronic interlock can be replaced with an optional (extra cost) mechanical interlock if required.
10. Refer to Table H-2 for control wiring connections.
11. Refer to Parallel Redundant System manual for details.
12. Maintenance bypass input neutral feeder must be supplied if an AUTOTRANSFORMER is used.

**LEGEND**

- MIS: MAINTENANCE ISOLATION BREAKER  
 MBP: MAINTENANCE BYPASS BREAKER  
 BIB: BYPASS INPUT BREAKER  
 SKRU: SOLENOID KEY RELEASE UNIT (MECHANICAL INTERLOCK)  
 PTC: PARALLEL TIE CABINET  
 RT: REVERSE TRANSFER  
 T1: AUTO or ISOLATION XFMR

110100070

DESCRIPTION:	<b>ONELINE – MBM225 (225kVA), PARALLEL, 480:208VAC</b>	
DRAWING NO:	164201233–11	SHEET: 1 of 1

**Table E. Ratings & External Wiring Requirements for  
MBM300 (225 & 300kVA) 480:208VAC/600:208VAC**

<b>Rating and External Wiring Requirement</b>		<b>Units</b>	<b>Rating 60 Hz</b>			
<b>Basic unit rating at 0.8 lagging PF load</b>		<b>KVA KW</b>	<b>300 240</b>		<b>225 180</b>	
MBM Input Voltage/UPS Bypass Input MBM Output Voltage		VOLTS VOLTS	480 208	600 208	480 208	600 208
<b>A</b>	AC Input to Maintenance Bypass (3) Phases, (1) Neutral (1) Ground (See Note)	AMPS	360	288	271	217
	Conductor Size Number per Phase	AWG/MCM (each)	250 (2)	250 (2)	250 (2)	250 (2)
<b>B</b>	AC Input to UPS Bypass (3) Phases, (1) Ground	AMPS	360	288	271	217
	Conductor Size Number per Phase	AWG/MCM (each)	250 (2)	250 (2)	250 (2)	250 (2)
<b>C</b>	AC Output to Critical Load (3) Phases, (1) Neutral, (1) Ground	AMPS	833	833	625	625
	Conductor Size Number per Phase	AWG/MCM (each)	400 (4)	400 (4)	400 (3)	400 (3)
<b>D</b>	UPS/PTC Output to MBM Cabinet (MIS) (3) Phases, (1) Neutral, (1) Ground	AMPS	360	288	271	217
	Conductor Size Number per Phase	AWG/MCM (each)	250 (2)	250 (2)	250 (2)	250 (2)
<b>E</b>	Control Wiring to UPS (2) Conductors	VOLTS AMPS	120 1	120 1	120 1	120 1

- Note: 1. Callout letters **A, B, C, D,** and **E** map to drawing 164201233–13 (Reverse Transfer Connection) and 164201233–14 (Parallel Connection). Read and understand the notes on these drawings while planning your installation.
2. Conductor is sized per circuit breaker frame size.

<i>DESCRIPTION:</i>	
<b>INSTALLATION NOTES – TABLE E</b>	
<i>DRAWING NO:</i>	164201233–12
<i>SHEET:</i>	1 of 1

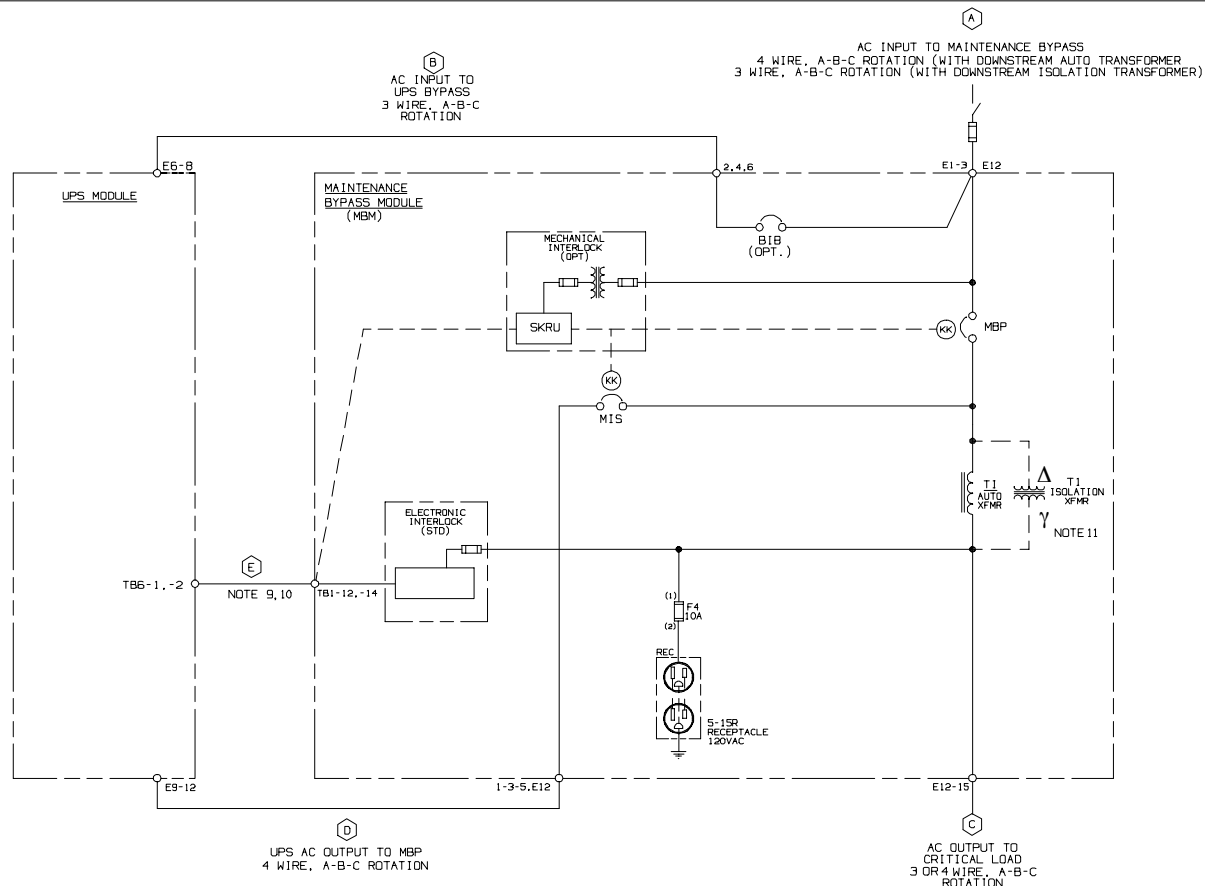

Read and understand the following notes while planning your installation:

1. Refer to national and local electric codes for acceptable external wiring practices.
2. Material and labor for external wiring requirements are to be provided by others.
3. For external wiring requirement, including the minimum AWG size of external wiring, see the appropriate column in Table E. The power wiring for this equipment is rated at 90 degrees Celsius.
4. If an AUTOTRANSFORMER is used, the output of the MBM is NOT a separately derived source. The output neutral shall NOT be bonded to equipment ground in the MBM cabinet.  
If an ISOLATION TRANSFORMER is used, the output of the MBM is a separately derived source. Output neutral is bonded to equipment ground through the main bonding jumper. Refer to NEC and local codes for proper grounding practices.
5. The maintenance bypass (MBM) source must contain overcurrent protection with the maximum trip setting of 125% of the full load input current in Table E.
6. The bypass feed into this equipment utilizes either three or four wires. The rectifier feed into this equipment utilizes three wires. However, the phases must be symmetrical about ground (i.e., from a Wye source) for proper equipment operation. Failure to follow these instructions will void the product warranty..
7. Transfer sequence instructions for the MBM are placed on the breaker access panel behind the cabinet doors.
8. Control wiring must be installed in separate conduit from the power wiring.
9. Electronic interlock is a standard part of the maintenance bypass module cabinet. This electronic interlock can be replaced with an optional (extra cost) mechanical interlock if required.
10. Refer to Table H-1 for control wiring connections.
11. Maintenance bypass input neutral feeder must be supplied if an AUTOTRANSFORMER is used.

**LEGEND**

- MIS: MAINTENANCE ISOLATION BREAKER  
 MBP: MAINTENANCE BYPASS BREAKER  
 BIB: BYPASS INPUT BREAKER  
 SKRU: SOLENOID KEY RELEASE UNIT (MECHANICAL INTERLOCK)  
 PTC: PARALLEL TIE CABINET  
 RT: REVERSE TRANSFER  
 T1: AUTO or ISOLATION XFMR

110100077

DESCRIPTION: **ONELINE – MBM300 (225–300kVA), RT 480:208VAC, 600:208VAC**

DRAWING NO: 164201233–13

SHEET: 1 of 1

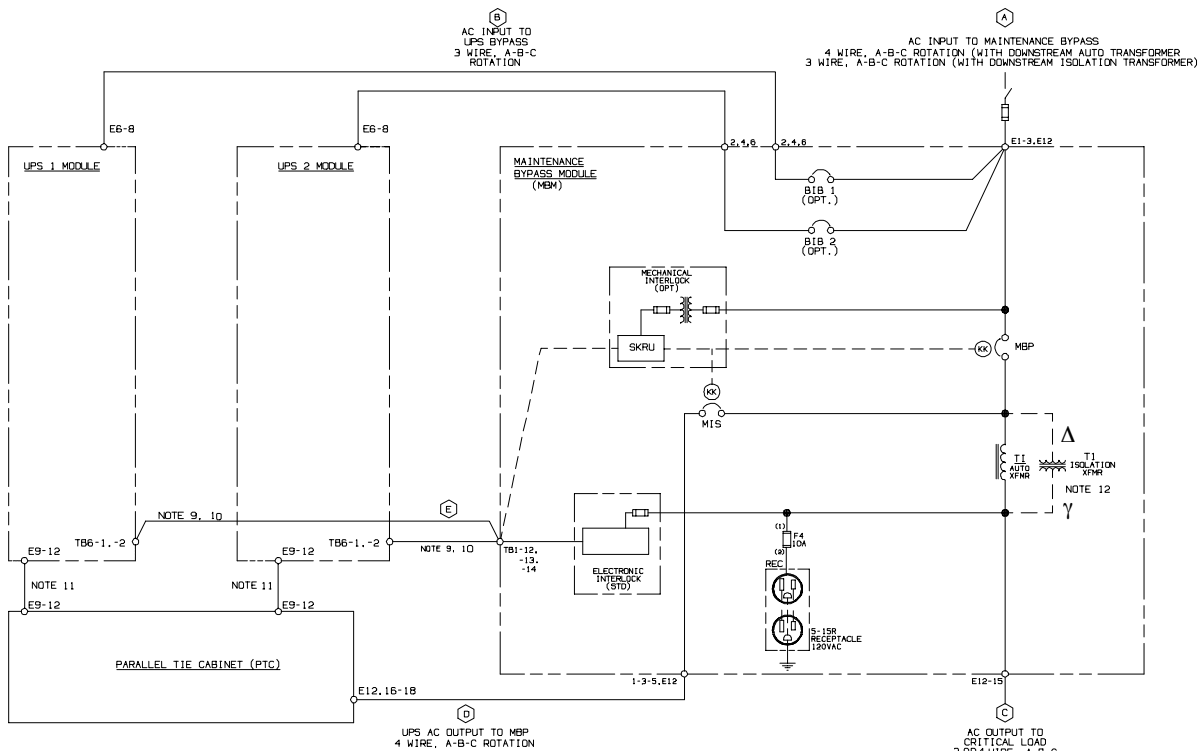

Read and understand the following notes while planning your installation:

1. Refer to national and local electric codes for acceptable external wiring practices.
2. Material and labor for external wiring requirements are to be provided by others.
3. For external wiring requirement, including the minimum AWG size of external wiring, see the appropriate column in Table E. The power wiring for this equipment is rated at 90 degrees Celsius.
4. If an AUTOTRANSFORMER is used, the output of the MBM is NOT a separately derived source. The output neutral shall NOT be bonded to equipment ground in the MBM cabinet. If an ISOLATION TRANSFORMER is used, the output of the MBM is a separately derived source. Output neutral is bonded to equipment ground through the main bonding jumper. Refer to NEC and local codes for proper grounding practices.
5. The maintenance bypass (MBM) source must contain overcurrent protection with the maximum trip setting of 125% of the full load input current in Table E.
6. The bypass feed into this equipment utilizes either three or four wires. The rectifier feed into this equipment utilizes three wires. However, the phases must be symmetrical about ground (i.e., from a Wye source) for proper equipment operation. Failure to follow these instructions will void the product warranty.
7. Transfer sequence instructions for the MBM are placed on the breaker access panel behind the cabinet doors.
8. Control wiring must be installed in separate conduit from the power wiring.
9. Electronic interlock is a standard part of the maintenance bypass module cabinet. This electronic interlock can be replaced with an optional (extra cost) mechanical interlock if required.
10. Refer to Table H-2 for control wiring connections.
11. Refer to Parallel Redundant System manual for details.
12. Maintenance bypass input neutral feeder must be supplied if an AUTOTRANSFORMER is used.

**LEGEND**

- MIS: MAINTENANCE ISOLATION BREAKER  
 MBP: MAINTENANCE BYPASS BREAKER  
 BIB: BYPASS INPUT BREAKER  
 SKRU: SOLENOID KEY RELEASE UNIT (MECHANICAL INTERLOCK)  
 PTC: PARALLEL TIE CABINET  
 RT: REVERSE TRANSFER  
 T1: AUTO or ISOLATION XFMR

110100078

<b>DESCRIPTION:</b> ONELINE – MBM300 (225–300kVA), PARALLEL, 480:208VAC, 600:208VAC	
<b>DRAWING NO:</b> 164201233–14	<b>SHEET:</b> 1 of 1

**Table F. Circuit Breaker Requirements for  
MBM225 (225kVA), MBM300 (200-300kVA),  
380:380VAC, 400:400VAC, 415:415VAC, 600:600VAC,  
480:208VAC, 600:208VAC, 208:208VAC, 480:480VAC**

MBM FAMILY	MBM Model No.	Vin/Vout	Iint/Iout	BIB1 & BIB2		MBP & MIS	
				Frame/Trip	Instantaneous Trip Range	Frame/Trip	Instantaneous Trip Range
<b>MBM225 225kVA</b>	MBM225/225-48/20	480V/208V	271A/625A	800A/640A	1200-9600A	800A/640A	1200-9600A
	MBM225/225-20/20	208V/208V	625A/625A	800A/640A	1200-9600A	800A/640A	1200-9600A
<b>MBM300</b>							
200KVA	MBM300/200-38/38	380V/380V	290A/290A	400A/320A	600-4800A	400A/320A	600-4800A
	MBM300/200-40/40	400V/400V	290A/290A	400A/320A	600-4800A	400A/320A	600-4800A
	MBM300/200-41/41	415V/415V	290A/290A	400A/320A	600-4800A	400A/320A	600-4800A
225KVA	MBM300/225-48/20	480V/208V	271A/625A	400A/320A	600-4800A	400A/320A	600-4800A
	MBM300/225-48/48	480V/480V	271A/271A	400A/280A	600-4800A	400A/280A	600-4800A
	MBM300/225-60/60	600V/600V	217A/217A	400A/240A	600-4800A	400A/240A	600-4800A
	MBM300/225-60/20	600V/208V	217A/625A	400A/240A	600-4800A	400A/240A	600-4800A
250KVA	MBM300/250-38/38	380V/380V	360A/360A	400A/380A	600-4800A	400A/380A	600-4800A
	MBM300/250-40/40	400V/400V	360A/360A	400A/380A	600-4800A	400A/380A	600-4800A
	MBM300/200-41/41	415V/415V	360A/360A	400A/380A	600-4800A	400A/380A	600-4800A
300KVA	MBM300/300-48/20	480V/208V	360A/833A	400A/400A	600-4800A	400A/400A	600-4800A
	MBM300/300-48/48	480V/480V	360A/360A	400A/380A	600-4800A	400A/380A	600-4800A
	MBM300/300-60/60	600V/600V	289A/289A	400A/320A	600-4800A	400A/320A	600-4800A
	MBM300/300-60/20	600V/208V	289A/833A	400A/320A	600-4800A	400A/320A	600-4800A
400KVA	MBM500/400-48/48	480V/480V	481A/481A	600A/540A	900-7200A	600A/540A	900-7200A
500KVA	MBM500/500-48/48	480V/480V	600A/600A	600A/600A	900-7200A	600A/600A	900-7200A

NOTE: Model Number Legend.

1. MBM225/225-20/20 means MBM cabinet, Family 225, 225kVA, 208V (input) and 208V (output).
2. MBM300/200-38/38 means MBM cabinet, Family 300, 200kVA, 380V (input) and 380V (output).
3. All breakers are 100% UL rated with Interrupting Capacity (IC) of 65kAIC@480VAC.

DESCRIPTION:

**INSTALLATION NOTES – TABLE F**

DRAWING NO:

164201233-15

SHEET:

1 of 1



**Table G. Power Cable Terminations**

Terminal Function	Terminal	Function	With Optional BIB			Without Optional BIB			MBM Family (kVA) (see note below)
			Size of Pressure Terminal	Tightening Torque N-M (lb-in)	Int. Hex Size (In.)	Size of Pressure Terminal	Tightening Torque N-M (lb-in)	Int. Hex Size (In.)	
AC Input to MBM	E1, E2, E3	Phase A, Phase B, Phase C	4 – #2-600 kcmil (Note 2)	56.5 (500)	1/2	3 – #3/0-400 kcmil (Note 3)	42.4 (375)	5/16	MBM225 (225kVA) 20/20 MBM500 (400–500kVA) 48/48
			2 – #6-350 kcmil (Note 2)	31.1 (275)	3/8	2 – #3/0-250 kcmil (Note 3)	31.1 (275)	5/16	MBM300 (200-300kVA) 38/38, 48/48, 60/60, 60/20, 48/20
			4 – #2-600 kcmil (Note 4)	56.5 (500)	1/2	4 – #2-600 kcmil (Note 4)	56.5 (500)	1/2	MBM225 (225kVA) 48/20
AC Input to UPS Bypass (BIB breaker Load side)	BIB–2, BIB–4, BIB–6	Phase A, Phase B, Phase C	3 – #3/0-400 kcmil	42.4 (375)	5/16	N/A	N/A	N/A	MBM225 (225kVA) All Models MBM500 (400–500kVA) 48/48
			2 – #3/0-250 kcmil	31.1 (275)	5/16	N/A	N/A	N/A	MBM300 (200-300kVA) All Models
UPS Output to MBM (MIS breaker Line side)	MIS–1, MIS–3, MIS–5	Phase A, Phase B, Phase C	3 – #3/0-400 kcmil	42.4 (375)	5/16	3 – #3/0-400 kcmil	42.4 (375)	5/16	MBM225 (225kVA) All Models MBM500 (400–500kVA) 48/48
			2 – #3/0-250 kcmil	31.1 (275)	5/16	2 – #3/0-250 kcmil	31.1 (275)	5/16	MBM300 (200-300kVA) All Models
MBM Output to Critical Load	E13, E14, E15	Phase A, Phase B, Phase C	2 – #6-350 kcmil	31.1 (275)	3/8	2 – #6-350 kcmil	31.1 (275)	3/8	MBM300 (200-300kVA) 38/38, 48/48, 60/60
			4 – #2-600 kcmil	56.5 (500)	1/2	4 – #2-600 kcmil	56.5 (500)	1/2	MBM225 (225kVA) All Models, MBM300 (225-300kVA) 48/20, 60/20, MBM500 (400–500kVA) 48/48,
Neutral Lug	E12	Neutral	12 – #2-500 kcmil	56.5 (500)	1/2	12 – #2-500 kcmil	56.5 (500)	1/2	MBM225 (225kVA) All Models, MBM300 (200-300kVA) All Models, MBM500 (400–500kVA) 48/48,
Customer Ground Lug	Ground	Ground	2 – #6-350 kcmil	31.1 (275)	3/8	2 – #6-350 kcmil	31.1 (275)	3/8	MBM225 (225kVA) 20/20 MBM300 (200-300kVA) 48/48, 60/60, 38/38, MBM500 (400–500kVA) 48/48
			4 – #2-600 kcmil	56.5 (500)	1/2	4 – #2-600 kcmil	56.5 (500)	1/2	MBM225 (225kVA) 48/20 MBM300 (225-300kVA) 48/20, 60/20

**NOTES: Model Number Legend**

- 38/38: 380VAC in–380VAC out; 48/48: 480VAC in–480VAC out; 60/60: 600VAC in–600VAC out  
48/20: 480VAC in–208VAC out; 60/20: 600VAC in–208VAC out; 20/20: 208VAC in–208VAC out
- AC input wiring is connected to input lugs E1 – E3. These lugs are located on the right side of BIB breaker.
- AC input wiring is connected directly to the line side of MBP breaker (MBP–1, MBP–3, and MBP–5).
- AC input wiring is connected to input lugs E1 – E3.

<i>DESCRIPTION:</i>	
<b>INSTALLATION NOTES – TABLE G</b>	
<i>DRAWING NO:</i>	164201233–16
<i>SHEET:</i>	1 of 1

Table H-1. Control Wiring Requirements and Termination Requirement for Reverse Transfer (RT) System.						
Connecting Point in MBM Cabinet	Size of Pressure Termination (lb-in)	Connection Point in UPS	Size of Pressure Termination (lb-in)	Recommended Wire Size	Maximum Voltage and Current	Remarks
TB1-12	#18-#8 (55)	TB6-1	#18-#8 (55)	#18-#14	120VAC 1.0A	See Fig 1. (Twisted Pair)
TB1-14		TB6-2				

Table H-2. Control Wiring Requirements and Termination Requirement for Parallel Redundant System.						
Connecting Point in MBM Cabinet	Size of Pressure Termination (lb-in)	Connection Point in UPS	Size of Pressure Termination (lb-in)	Recommended Wire Size	Maximum Voltage and Current	Remarks
TB1-12 TB1-13	#18-#8 (55)	TB6-1 (UPS1) TB6-1 (UPS2)	#18-#8 (55)	#18-#14	120VAC 1.0A	See Fig 2. (Twisted Pair)
TB1-13 TB1-14		TB6-2 (UPS1) TB6-2 (UPS2)				

NOTES FOR TABLES H-1 AND H-2:

1. Install the copper wiring in a conduit separate from the power wiring.
2. Control wiring is NEC Class 1.
3. Control wiring from each UPS Module should be twisted.

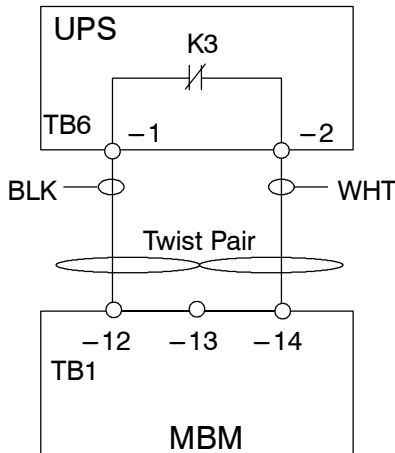

Figure 1. (Reverse Transfer)

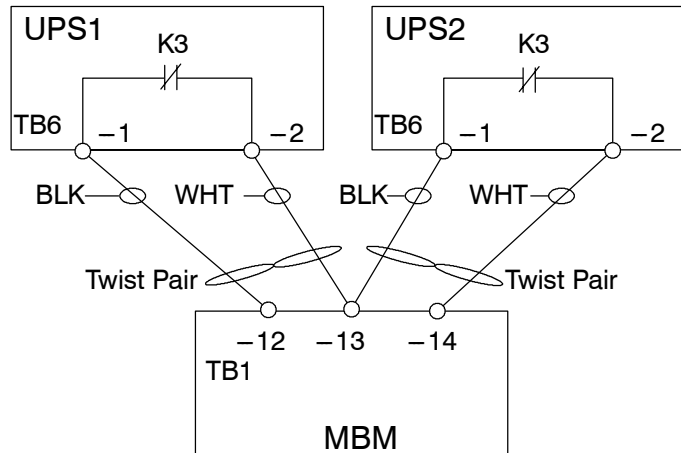

Figure 2. (Parallel Redundant)

DESCRIPTION:		
<b>INSTALLATION NOTES - TABLE H</b>		
DRAWING NO:	164201233-17	SHEET: 1 of 1

**Table I. Power and Control Cable Conduit**

	MBM INPUT			MBM OUTPUT			MBM TO UPS BYPASS			MBM TO UPS OUTPUT		
	# Wires in Conduit	Min. Conduit Trade Size	# of Conduits	# Wires in Conduit	Min. Conduit Trade Size	# of Conduits	# Wires in Conduit	Min. Conduit Trade Size	# of Conduits	# Wires in Conduit	Min. Conduit Trade Size	# of Conduits
MBM225/225-20/20	5	3	3	5	3	3	5	3	3	5	3	3
MBM225/225-48/20	4 or 5	3	2	5	3	3	4 or 5	3	3	5	3	3
MBM300/200-38/38 MBM300/200-40/40 MBM300/200-41/41	4 or 5	3	2	4 or 5	3	2	4 or 5	3	2	4 or 5	3	2
MBM300/250-38/38 MBM300/250-40/40 MBM300/250-41/41	4 or 5	3	2	4 or 5	3	2	4 or 5	3	2	4 or 5	3	2
MBM300/225-48/48 MBM300/225-60/60 MBM300/300-48/48 MBM300/300-60/60	4 or 5	3	2	4 or 5	3	2	4 or 5	3	2	4 or 5	3	2
MBM300/225-48/20 MBM300/225-60/20	4 or 5	3	2	5	3	3	4 or 5	3	2	5	3	2
MBM300/300-48/20 MBM300/300-60/20	4 or 5	3	2	5	3	4	4 or 5	3	2	5	3	2
MBM500/400-48/48 MBM500/500-48/48	4 or 5	3	3	4 or 5	3	3	4 or 5	3	3	4 or 5	3	3

**NOTES:**

1. Per NEC Code all three-phase conductors must be run in the same conduit. If a neutral is used, it must be run in the same conduit as the phase conductors.
2. Conduit is sized to accommodate one neutral conductor (if applicable) and one ground conductor the same size as the phase conductors.
3. Conduit sizes were chosen from NEC Table 3A, 3B, and 3C, Type letters RHH, RHW, RHW-2, TW, THW, THHN, THHW, THW-2
3. Customer ground, size 2/0, can be run in any conduit listed in Table I.

<i>DESCRIPTION:</i>		<b>INSTALLATION NOTES – TABLE I</b>
<i>DRAWING NO:</i>	164201233–18	<i>SHEET:</i> 1 of 1

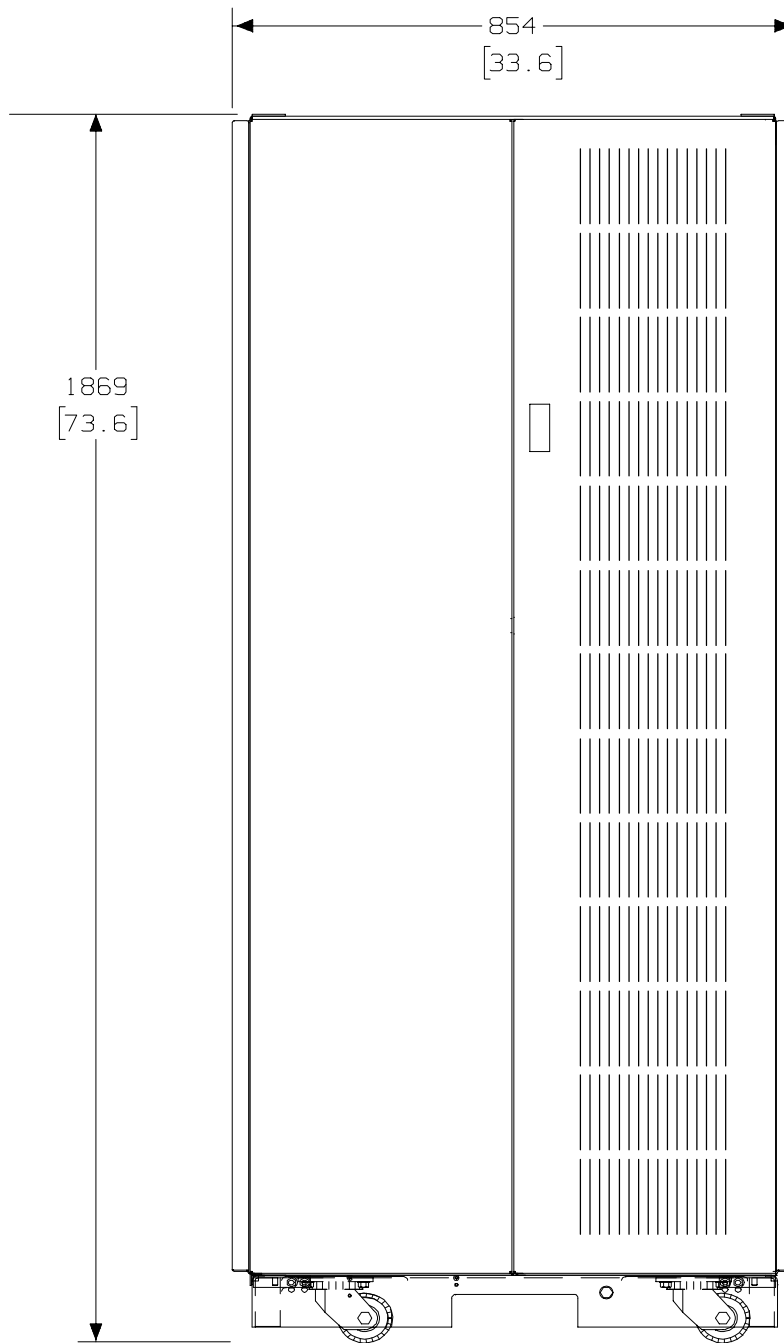

Dimensions are in millimeters (inches)

DESCRIPTION:	<b>TYPICAL MBM CABINET – 200–500kVA w/o XFMR</b>	
DRAWING NO:	164201233–19	SHEET: 1 of 3

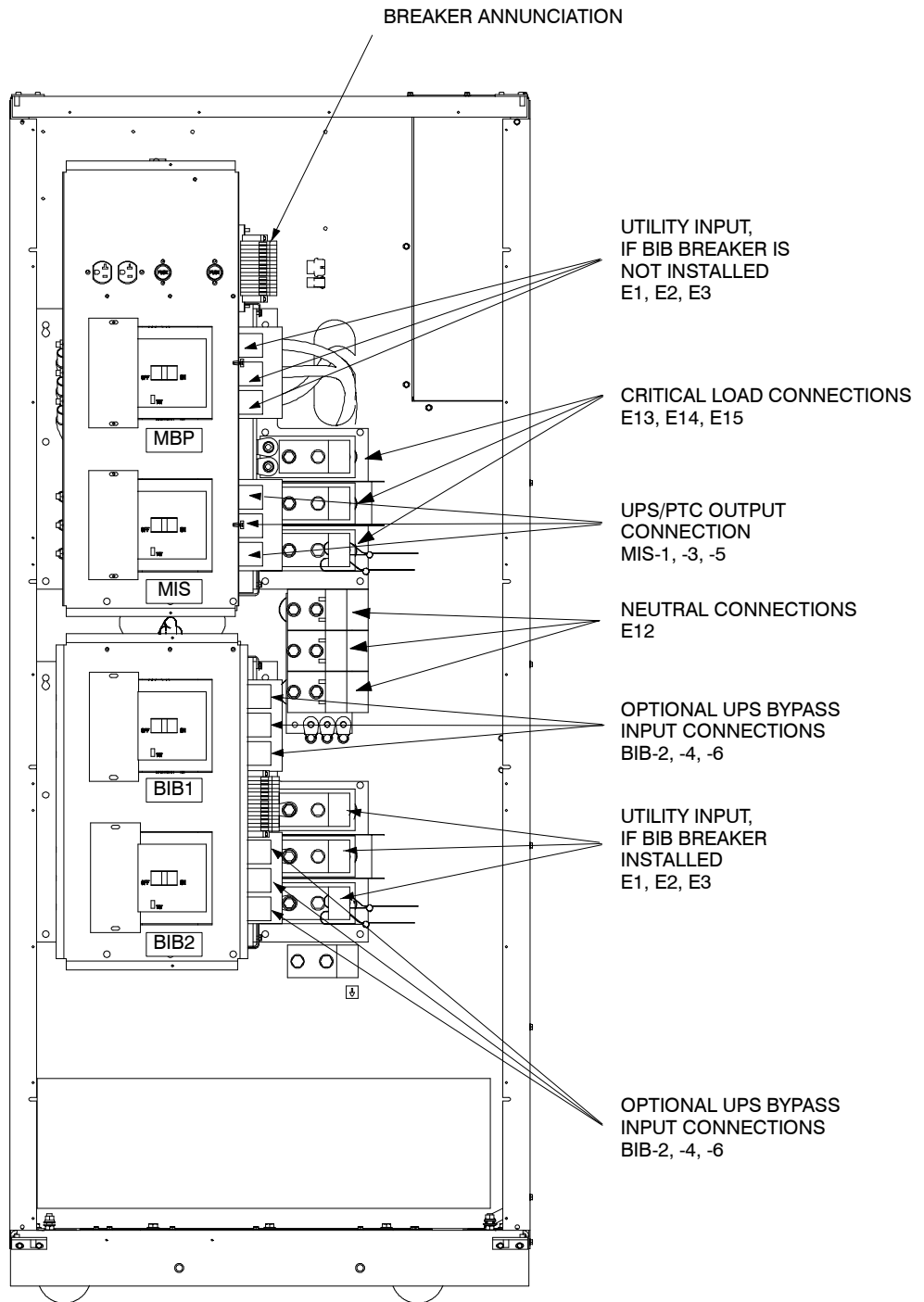

<b>DESCRIPTION:</b>		<b>TYPICAL MBM CABINET – 200–500kVA w/o XFMR, INTERIOR COMPONENTS</b>
<b>DRAWING NO:</b>	164201233–19	<b>SHEET:</b> 2 of 3

**TOP VIEW**  
(with shipping pallet)

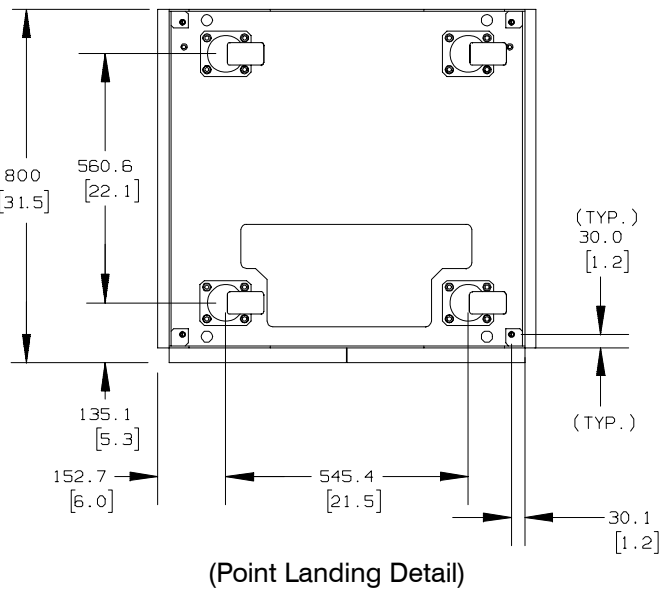
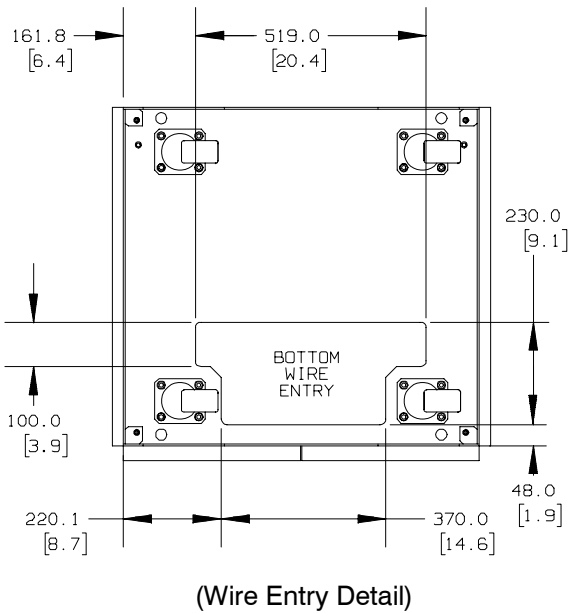
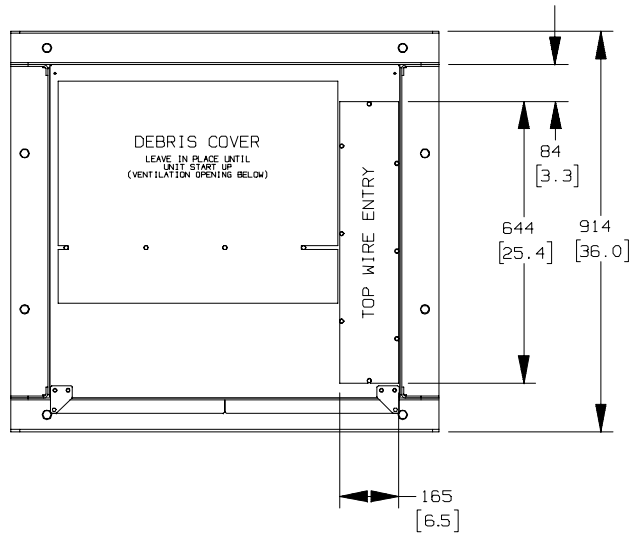

**BOTTOM VIEW**

Dimensions are in millimeters (inches)

<b>DESCRIPTION:</b>		<b>TYPICAL MBM CABINET –</b>
		<b>200–500kVA w/o XFMR, TOP &amp; BOTTOM VIEW</b>
<b>DRAWING NO:</b>	164201233–19	<b>SHEET:</b> 3 of 3

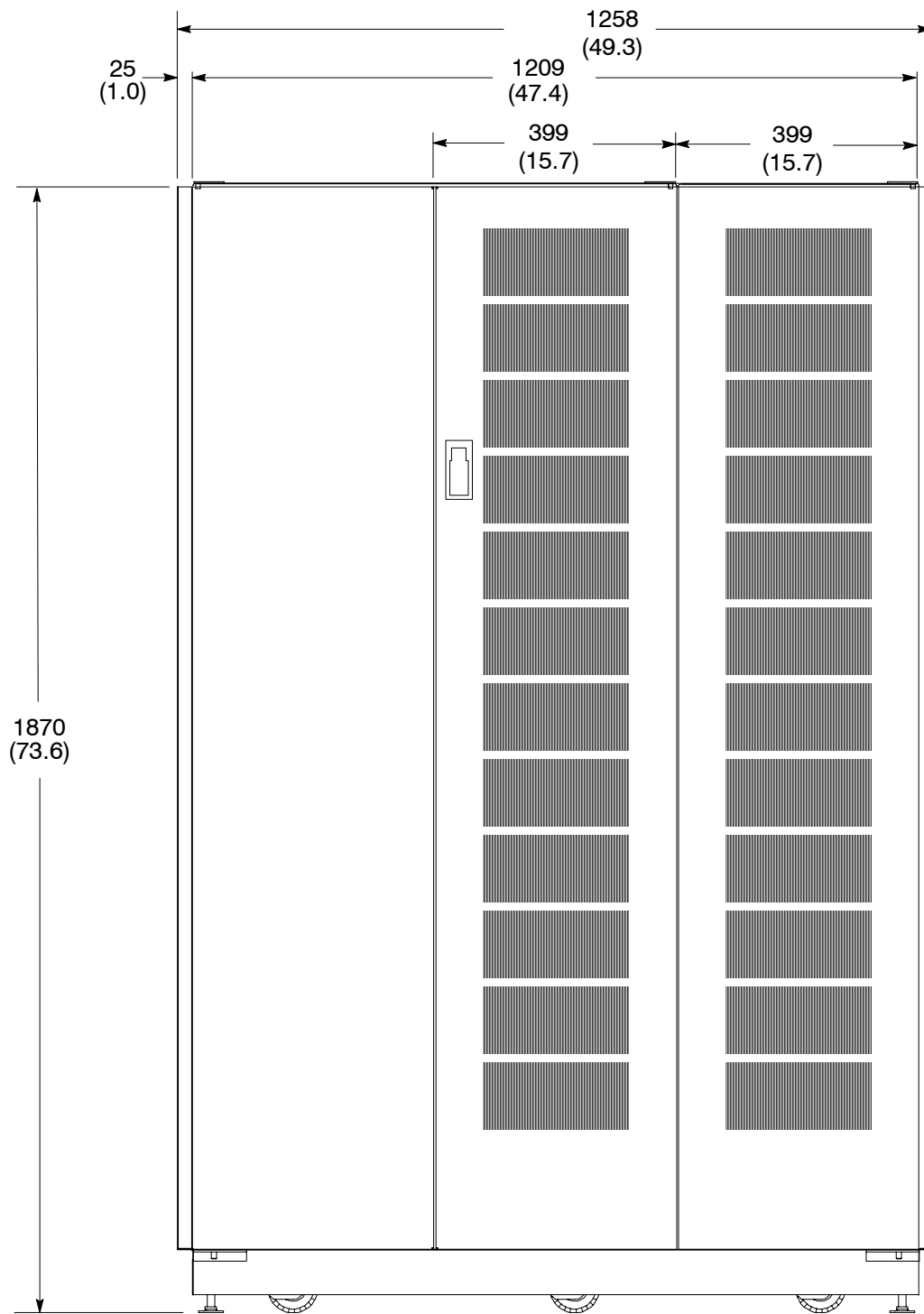

Dimensions are in millimeters (inches)

<b>DESCRIPTION: MBM CABINET – MBM225 and MBM300 with AUTO/ISOLATION TRANSFORMER</b>	
<b>DRAWING NO:</b> 164201233-20	<b>SHEET:</b> 1 of 3

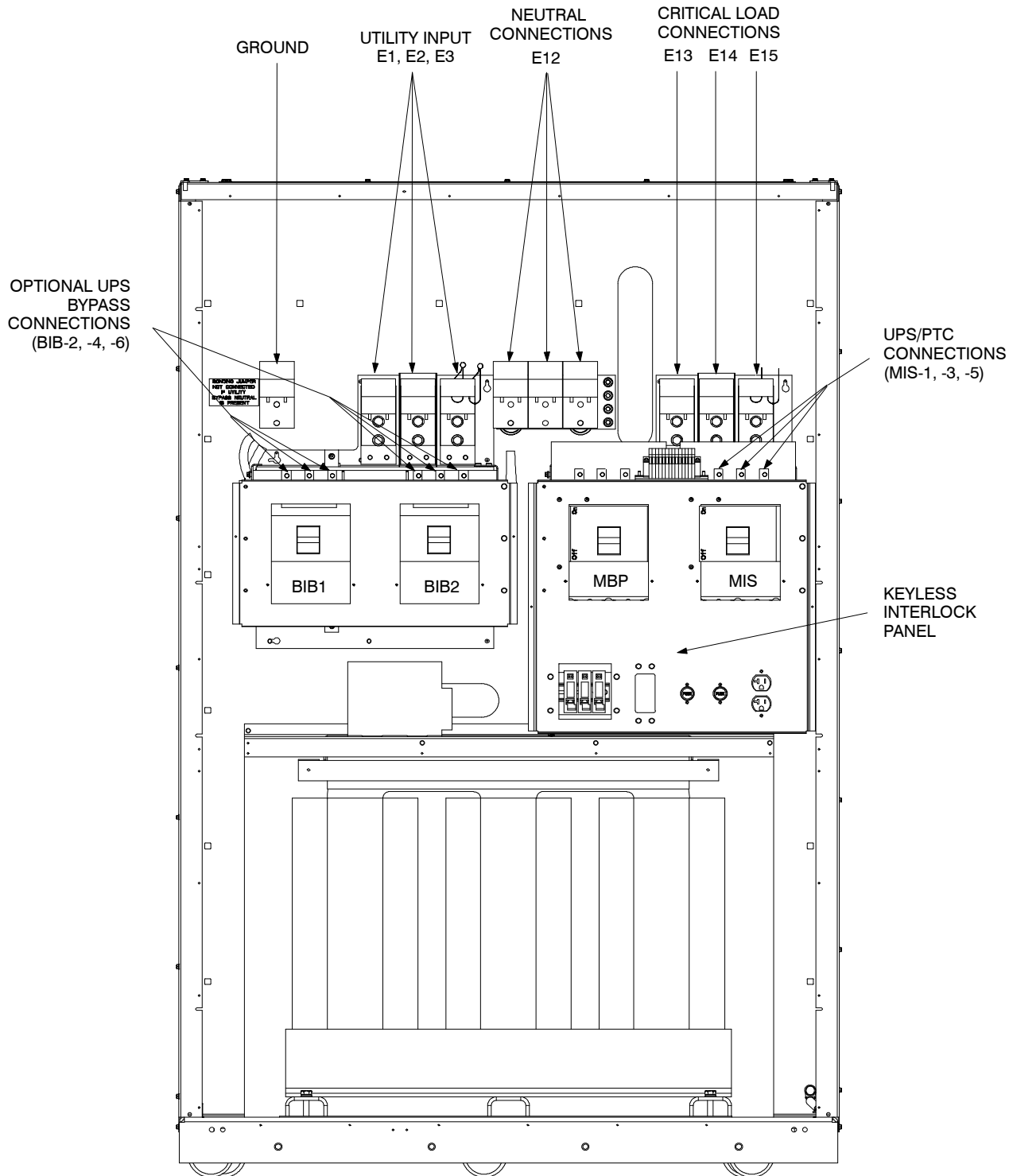

<b>DESCRIPTION:</b> MBM CABINET – MBM225–300kVA 480:208VAC or 600:208VAC with AUTO/ISOLATION XFMR	
<b>DRAWING NO:</b> 164201233–20	<b>SHEET:</b> 2 of 3



# CABINET TOP VIEW

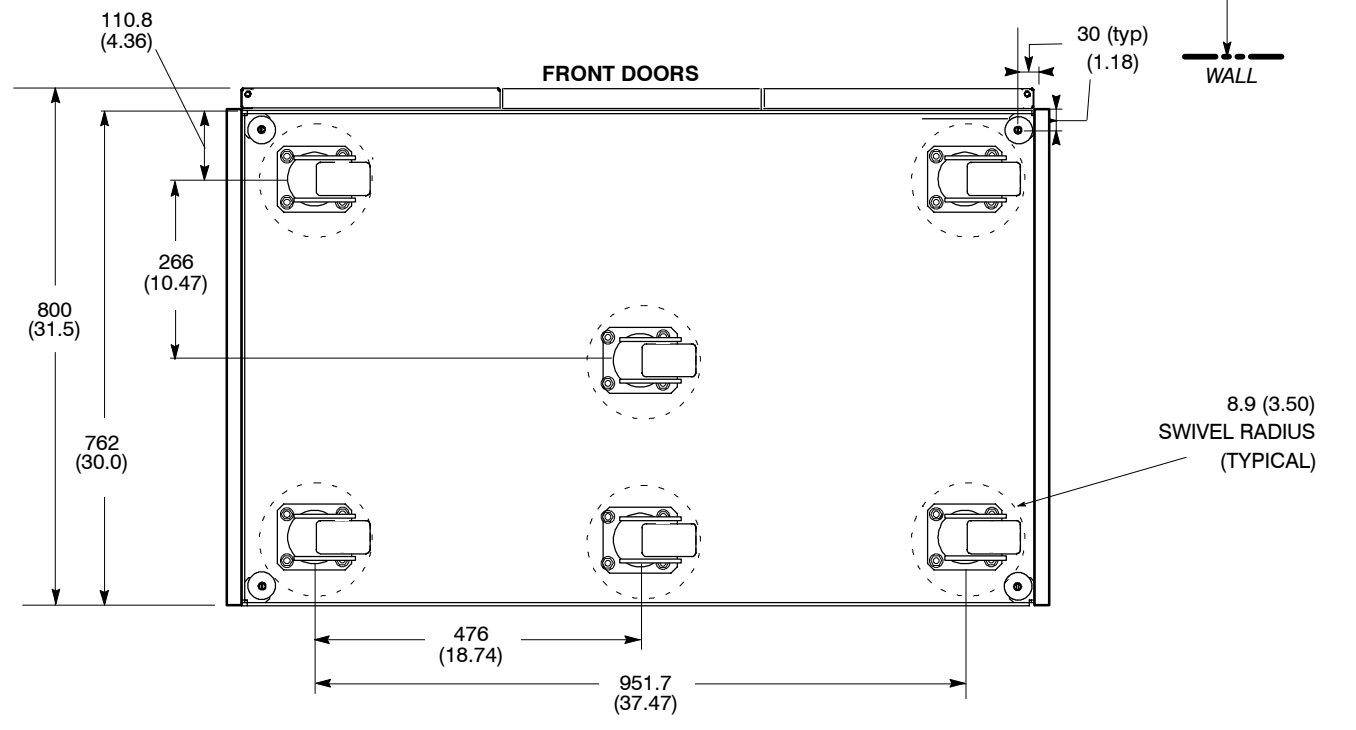
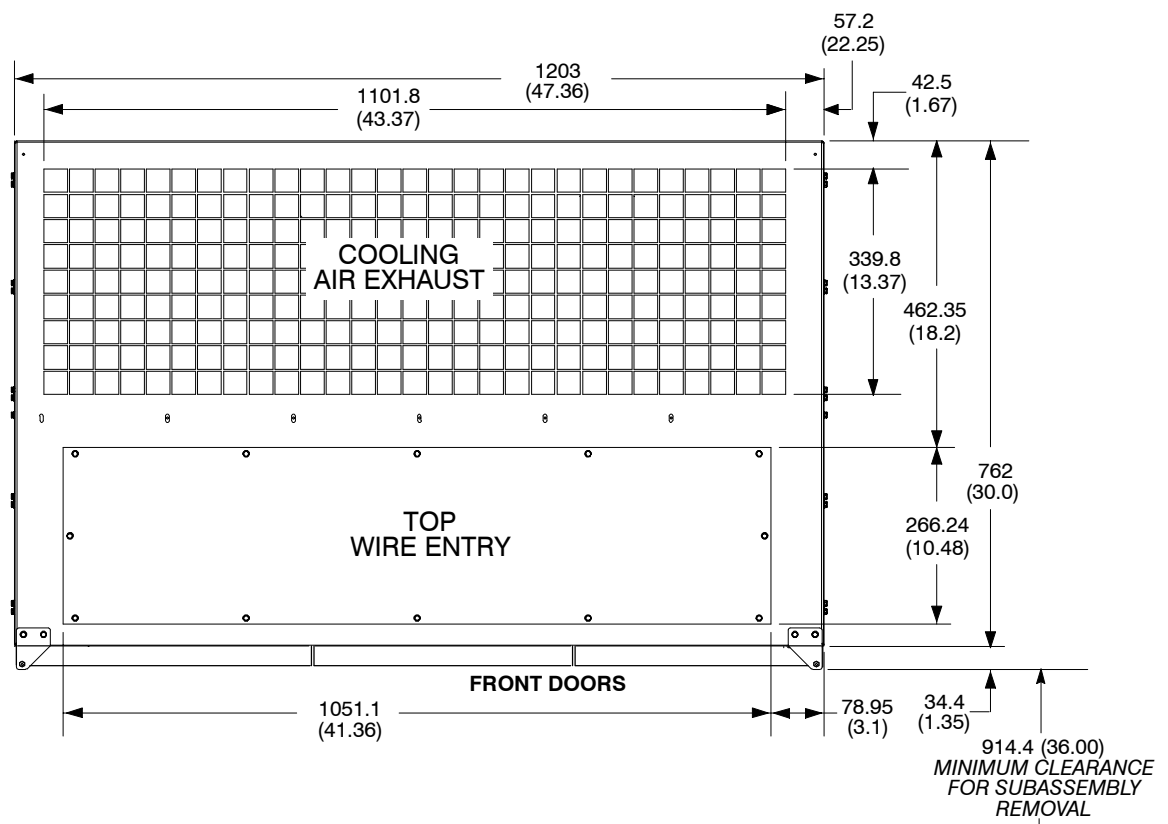

# CABINET BOTTOM VIEW

<b>DESCRIPTION:</b> MBM CABINET – MBM225, MBM300, with AUTO/ISOLATION TRANSFORMER	
<b>DRAWING NO:</b> 164201233-20	<b>SHEET:</b> 3 of 3

**This Page Intentionally Left Blank.**



164201233 Rev D