



POWERWARE[®]

9315

Sync Control

Installation/Operation Manual

164201140 Rev. E

IMPORTANT SAFETY INSTRUCTIONS

Instructions Importantes Concernant La Sécurité

SAVE THESE INSTRUCTIONS

Conserver Ces Instructions

This manual contains important instructions for your Uninterruptible Power Supply (UPS) system. You should follow these instructions during the installation and maintenance of the UPS, options, accessories, and batteries.

Cette notice contient des instructions importantes concernant la sécurité.

This equipment has been tested and found to comply with the limits for a Class A digital device, pursuant to Part 15 of the FCC Rules. These limits are designed to provide reasonable protection against harmful interference when the equipment is operated in a commercial environment. This equipment generates, uses, and can radiate radio frequency energy and, if not installed and used in accordance with the instruction manual, may cause harmful interference to radio communications. Operation of this equipment in a residential area is likely to cause harmful interference in which case the user will be required to correct the interference at their own expense.

WARNING:

This is a product for restricted sales distribution to informed partners. Installation restrictions or additional measures may be needed to prevent disturbances.

Table of Contents

- Introduction** **1**
 - Using This Manual 2
 - For More Information 2
 - Getting Help 3

- 1 Getting Started** **5**
 - Preparing the Site 5
 - Creating an Installation Plan 5
 - Environmental Considerations 5
 - Preparing for Wiring the Powerware Sync Control 6
 - Inspecting and Unpacking the Powerware Sync Control 6

- 2 Installing the Powerware Sync Control** **7**

- 3 Powerware Sync Control Operation** **19**
 - Preliminary Checks and Startup for UPS or SBM Systems Equipped with a Powerware Sync Control 19
 - Understanding Sync Control Operation 19
 - Operation 24
 - Customer Monitoring 26
 - Maintenance Operations 26

- Appendix A** **A-1**

List of Figures

Figure 1. Typical Powerware Sync Control	1
Figure 2. Powerware Sync Control Interface Location for 30–80 kVA Single Module Powerware 9315 UPS System ...	8
Figure 3. Powerware Sync Control Interface Location for 100–160 kVA Single Module Powerware 9315 UPS System	9
Figure 4. Powerware Sync Control Interface Locations for 200–300 kVA Single Module Powerware 9315 UPS System .	10
Figure 5. Powerware Sync Control Interface Location for 400–500 kVA Single Module Powerware 9315 UPS System .	11
Figure 6. Powerware Sync Control Interface Location for 750 kVA Single Module Powerware 9315 UPS System	12
Figure 7. Powerware Sync Control Interface Location for Powerware Hot Sync – Capacity System with 1200 Amp SBM	13
Figure 8. Powerware Sync Control Interface Location for Powerware Hot Sync – Capacity System with 2000 Amp SBM	14
Figure 9. Typical Powerware Sync Control TB6 Terminal Block Located in Powerware 9315 UPS Module	15
Figure 10. Location of SBM Customer Interface Panel Terminal Blocks TB3, TB4, and TB6	16
Figure 11. Typical Control Wiring Termination Locations for the Powerware Sync Control	17
Figure 12. Typical Powerware Sync Control Block Diagram for a Single Module Powerware 9315 UPS System	21
Figure 13. Typical Powerware Sync Control Block Diagram for a Powerware Hot Sync–Capacity System	22
Figure 14. Synchronization Reference Control	23
Figure 15. Powerware Sync Control Controls and Indicators	24

Introduction

The Powerware® Sync Control maintains the critical load outputs of two separate single module Powerware 9315 UPS or Powerware Hot Sync™ – Capacity systems in synchronization. This facilitates the uninterrupted transfer of the load from one load bus to another by means of downstream dual source solid state transfer switches. Without the load sync option, the possibility exists for the two system output (critical load) buses to become out of phase with each other. This condition occurs if suitable bypass sources are not available, or if the bypass sources feeding each system are not in sync with each other. An example of this condition would be if the two systems are supplied by separate diesel generator sets, or if the bypass sources for the two systems are lost. Figure 1 shows the front view of the Sync Control.

In addition, the Powerware Sync Control provides remote customer monitoring of sync control operation and alarms. Refer to Chapter 3 for detailed information.

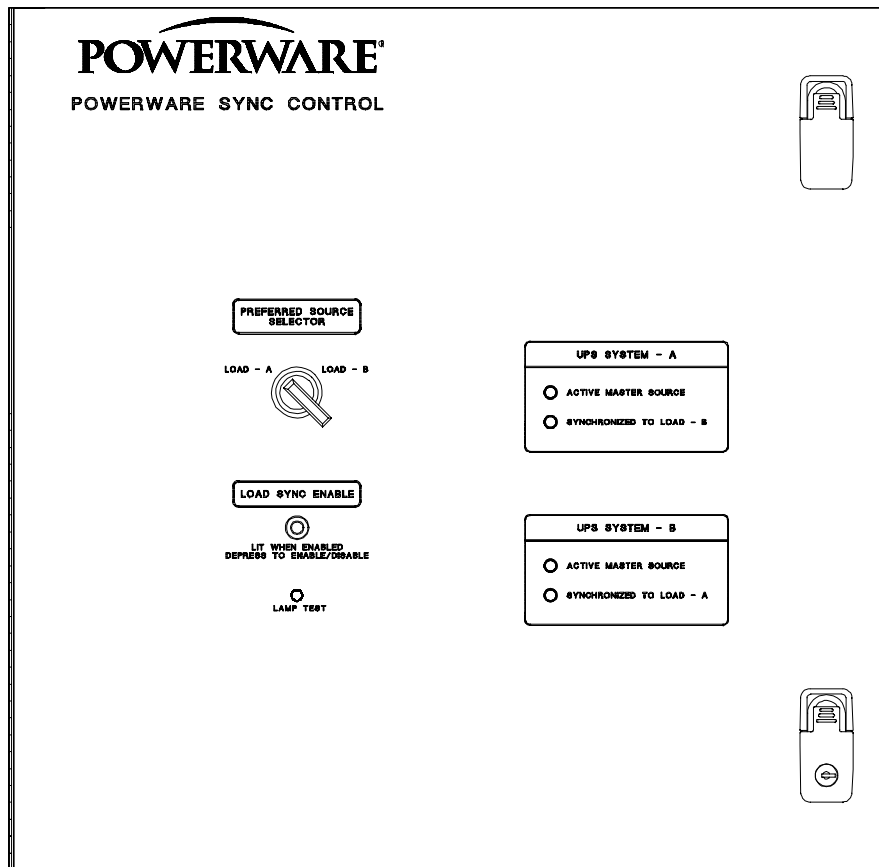

Figure 1. Typical Powerware Sync Control

Using This Manual

This manual contains control enclosure dimensions and mounting information, control wiring requirements, and operation procedures for the Powerware Sync Control. The text uses these conventions:

- **Bold type** highlights important concepts in discussions, key terms in procedures, and menu options.
- *Italic type* highlights notes, references to other system manuals, references to other sections of this manual, and new terms where they are defined.
- Rectangular boxes containing bold type are warnings or cautions that pertain to the system or its electrical connections. This important information indicates possible dangers pertaining to personnel safety, equipment damage, critical load protection, or operational concerns.

Before installation of the Powerware Sync Control, read through each installation procedure.

For More Information

For more information on the installation and operation of the UPS system and its accessories, refer to the following:

164200252	<i>Powerware® 9315 30–160 kVA UPS Operation</i>
164201036	<i>Powerware® 9315 200–300 kVA UPS Operation</i>
164201119	<i>Powerware® 9315 400/500 (300–500 kVA) UPS Operation</i>
164201244	<i>Powerware® 9315 500/750 (500–750 kVA) UPS Operation/Installation</i>

Each manual describes the UPS cabinet Control and Monitor Panels, and explains the functions of the UPS; discusses the standard features of the UPS and optional accessories; provides procedures for starting and stopping the UPS, and information about maintenance and responding to system events.

Also described are the RS–485 and RS–232 serial communications capabilities of the UPS; the two communications ports on the Customer Interface Panel inside the UPS and how to connect optional remote accessories to your UPS system; and provide information about enabling, disabling, and customizing building alarms.

164200253	<i>Powerware® 9315 30–80 kVA UPS Installation</i>
164200292	<i>Powerware® 9315 100–160 kVA UPS Installation</i>
164201037	<i>Powerware® 9315 200–300 kVA UPS Installation</i>
164201118	<i>Powerware® 9315 400/500 (300–500 kVA) UPS Installation</i>
164201244	<i>Powerware® 9315 500/750 (500–750 kVA) UPS Operation/Installation</i>

Each manual contains the following information: how to prepare the site and plan for installation, detailed step-by-step procedures for installing each component of your system, how to join cabinets in a line-up-and-match system, detailed illustrations of cabinets and optional accessories, including dimensions and connection points.

164201150

**Powerware® 9315 Parallel Capacity/Redundant System
Installation and Operation (Powerware Hot Sync™ – Capacity)**

The manual contains the following information: how to prepare the site and plan for installation, detailed step-by-step procedures for installing the System Bypass Module (SBM), and detailed illustrations of cabinets and optional accessories, including dimensions and connection points.

Each manual describes the SBM Control Panel, and explains the functions of the Parallel Capacity/Redundant System; discusses the standard features of the Parallel Capacity/Redundant System and optional accessories; provides procedures for starting and stopping the Parallel Capacity/Redundant System, and information about maintenance and responding to system events.

Also described are the RS–485 and RS–232 serial communications capabilities of the Parallel Capacity/Redundant System; the two communications ports on the Customer Interface Panel inside the SBM and how to connect optional remote accessories to your Parallel Capacity/Redundant System; and provide information about enabling, disabling, and customizing building alarms.

Contact the local Field Service office for information on how to obtain copies of these manuals.

Getting Help

If you have a question about any of the information in this manual, or if you have a question this manual does not answer, please call Powerware Corporation Field Service:

United States	1-800-843-9433
Canada	1-800-461-9166
Outside the U.S.	Call your local representative

This Page Intentionally Left Blank.

1

Getting Started

This section describes the Powerware Sync Control. It contains instructions for inspecting the unit and basic site preparation procedures.

The Powerware Sync Control is shipped as a separate item. It weighs approximately 80 lbs and can be mounted on any surface that can safely bear its weight. See Appendix A for complete dimensions and wiring interconnection data.

Preparing the Site

For the Powerware Sync Control to operate at peak efficiency, the installation site should meet the environmental parameters outlined in the *Powerware 9315 Operation* manual provided with the single module Powerware 9315 UPS system or the *Powerware 9315 Installation and Operation* manual provided with the Powerware Hot Sync – Capacity system. The operating environment must accommodate the size and weight requirements supplied in the *Powerware® 9315 Installation* manual provided with the single module Powerware 9315 UPS system or the *Powerware 9315 Installation and Operation* manual provided with the Powerware Hot Sync – Capacity system.

The basic environmental requirements for operation of the Powerware Sync Control are:

Ambient Temperature Range:	0–40°C (32–104°F)
Recommended Operating Range:	20–25°C (68–77°F)
Maximum Relative Humidity:	95%

The Powerware Sync Control uses convection cooling to regulate internal component temperature.

Creating an Installation Plan

Before beginning to install the Powerware Sync Control, read and understand how this manual applies to the system being installed. It is important to note that UPS module installation procedures are contained in the *Powerware 9315 Installation* and/or *Powerware 9315 Installation/Operation* manual provided with the single module Powerware 9315 UPS system and the System Bypass Module (SBM) installation procedures are contained in the *Powerware 9315 Installation and Operation* manual provided with the Powerware Hot Sync – Capacity system. It is recommended to first understand how to install the UPS modules or the SBM. The information in Chapter 2 of this manual is a guide for installation of the Powerware Sync Control to the UPS modules or SBM.

Environmental Considerations

See the *Powerware 9315 Installation* manual provided with the Powerware 9315 UPS or Powerware Hot Sync – Capacity system.

Preparing for Wiring the Powerware Sync Control

See Tables 1, 2, and 3 in Appendix A of this manual for wiring requirements. The wiring for this equipment is rated at 75°C. If wire is run in an ambient temperature greater than 30°C, higher temperature rating and/or larger size wire may be necessary. For UPS external wiring requirements, including minimum AWG size of external wiring, see the *Powerware 9315 Installation* manual provided with the single module Powerware 9315 UPS system or the *Powerware 9315 Installation and Operation* manual provided with the Powerware Hot Sync – Capacity system.

NOTE: *Material and labor for external wiring are to be provided by designated personnel.*

Inspecting and Unpacking the Powerware Sync Control

The first task in preparing for installation of the Powerware Sync Control is inspecting and unpacking the unit. The unit arrives covered with protective packaging material.

1. Carefully inspect the outer packaging for evidence of damage during transit.

CAUTION:

Do not install a damaged Powerware Sync Control. Report any damage to the carrier and contact the local sales or service office immediately.

2. Remove the protective cardboard covering from the Powerware Sync Control, by cutting where indicated using a knife blade no longer than 25 mm (1 in.).
3. Remove the plastic bag and foam packing material. Please discard or recycle them in a responsible manner.

2

Installing the Powerware Sync Control

The Powerware Sync Control can be installed in your facility up to a maximum of 500 feet from the single module Powerware 9315 UPS or Powerware Hot Sync – Capacity system. Once the Sync Control has been moved to its installed location, unpacked, and inspected, it is ready for installation. This section discusses the typical installation of the Powerware Sync Control.

Refer to the following while installing the Powerware Sync Control:

- Figure 164201140–1 of Appendix A of this manual for mounting hole dimensions, conduit entrance locations, and equipment grounding terminal location.
- Detailed control wiring information is provided in Table 1 or 2 of Appendix A of this manual.
- Detailed customer Remote Monitoring system wiring information is provided in Table 3 of Appendix A of this manual.

Install Powerware Sync Control panel to the selected mounting location.

Complete all control wiring interconnections using Table 1 or 2 of Appendix A for wiring requirements. Complete all customer remote monitoring system wiring interconnections using Table 3 of Appendix A for wiring requirements. Figures 2 through 5 show the typical location of the TB1 and TB6 interconnect terminal blocks, within a single module Powerware 9315 UPS. Figure 6 shows customer TB2 connections for 750kVA unit. Figures 7 and 8 show the typical location of the System Bypass Module (SBM) Customer Interface Panel for the Powerware Hot Sync – Capacity. Figure 9 shows the TB6 interconnect terminal block within a single module Powerware 9315 UPS (500kVA and below). Figure 10 shows the TB3, TB4, and TB6 interconnect terminal blocks located on the SBM Customer Interface Panel. Figure 11 shows typical control wiring and power wiring terminations of the Powerware Sync Control. Also, refer to the Powerware 9315 UPS Installation manual provided with the single module Powerware 9315 UPS system or the Powerware 9315 Parallel Capacity/Redundant System (Hot Sync – Capacity) Installation manual provided with the SBM for location of UPS module and SBM cabinet wiring terminations.

NOTE: *Material and labor for external wiring are to be provided by designated personnel.*

WARNING:

Shut down all sources of power to the single module Powerware 9315 UPS or Powerware Hot Sync – Capacity system before connecting the control wiring to the Sync Control enclosure and UPS system or System Bypass Module (SBM). Hazardous voltages exist inside the UPS modules and in the Sync Control enclosure. Check all terminal conductors with a known serviceable voltmeter before connecting the wiring. Installation should only be performed by qualified personnel.

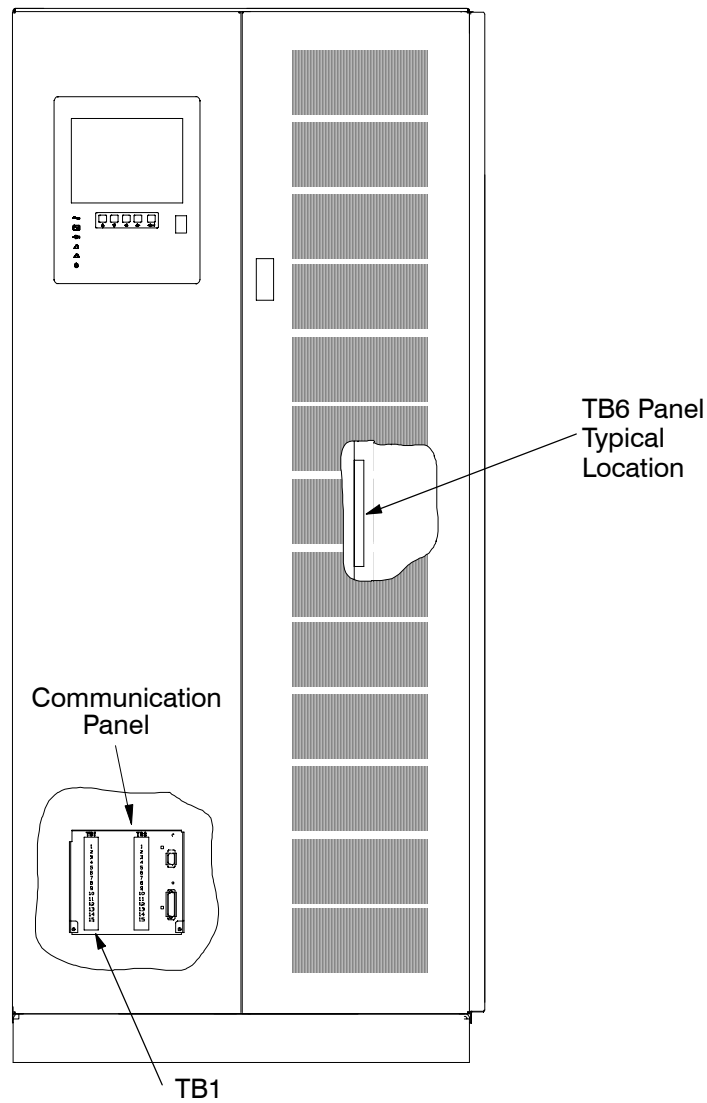

Figure 2. Powerware Sync Control Interface Location for 30–80 kVA Single Module Powerware 9315 UPS System

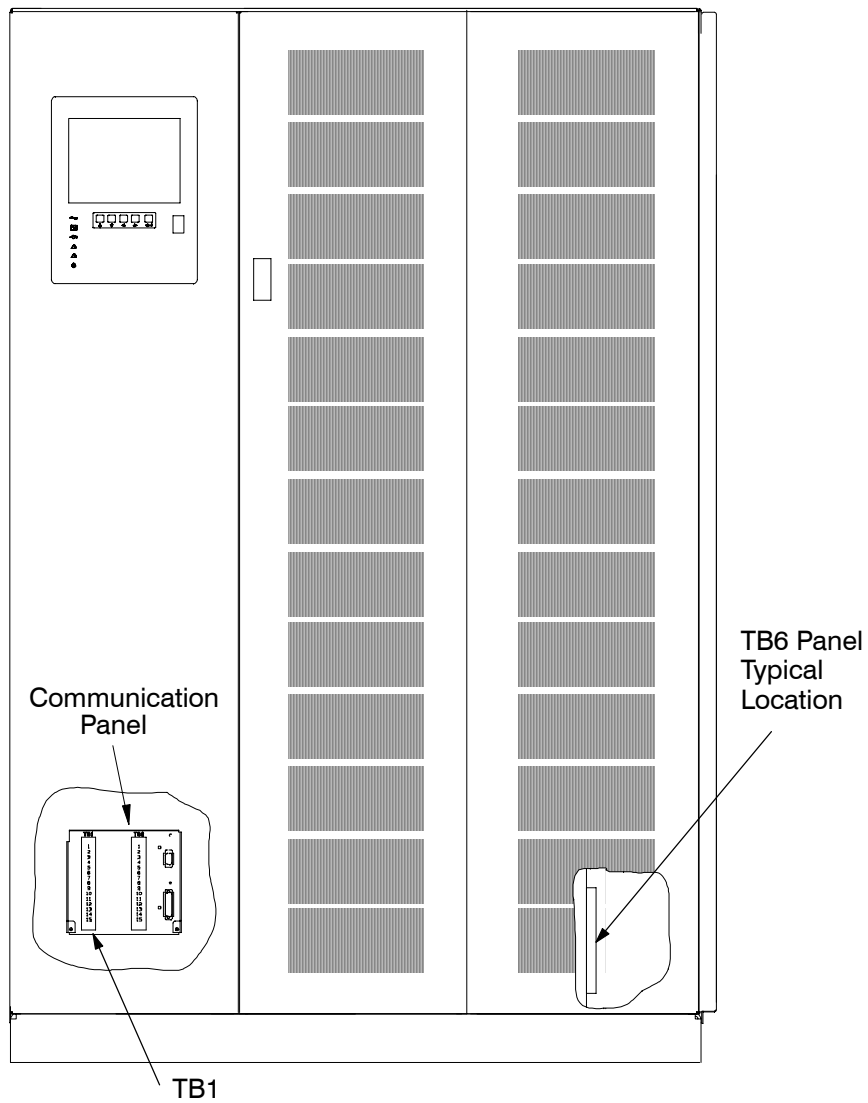

Figure 3. Powerware Sync Control Interface Location for 100–160 kVA Single Module Powerware 9315 UPS System

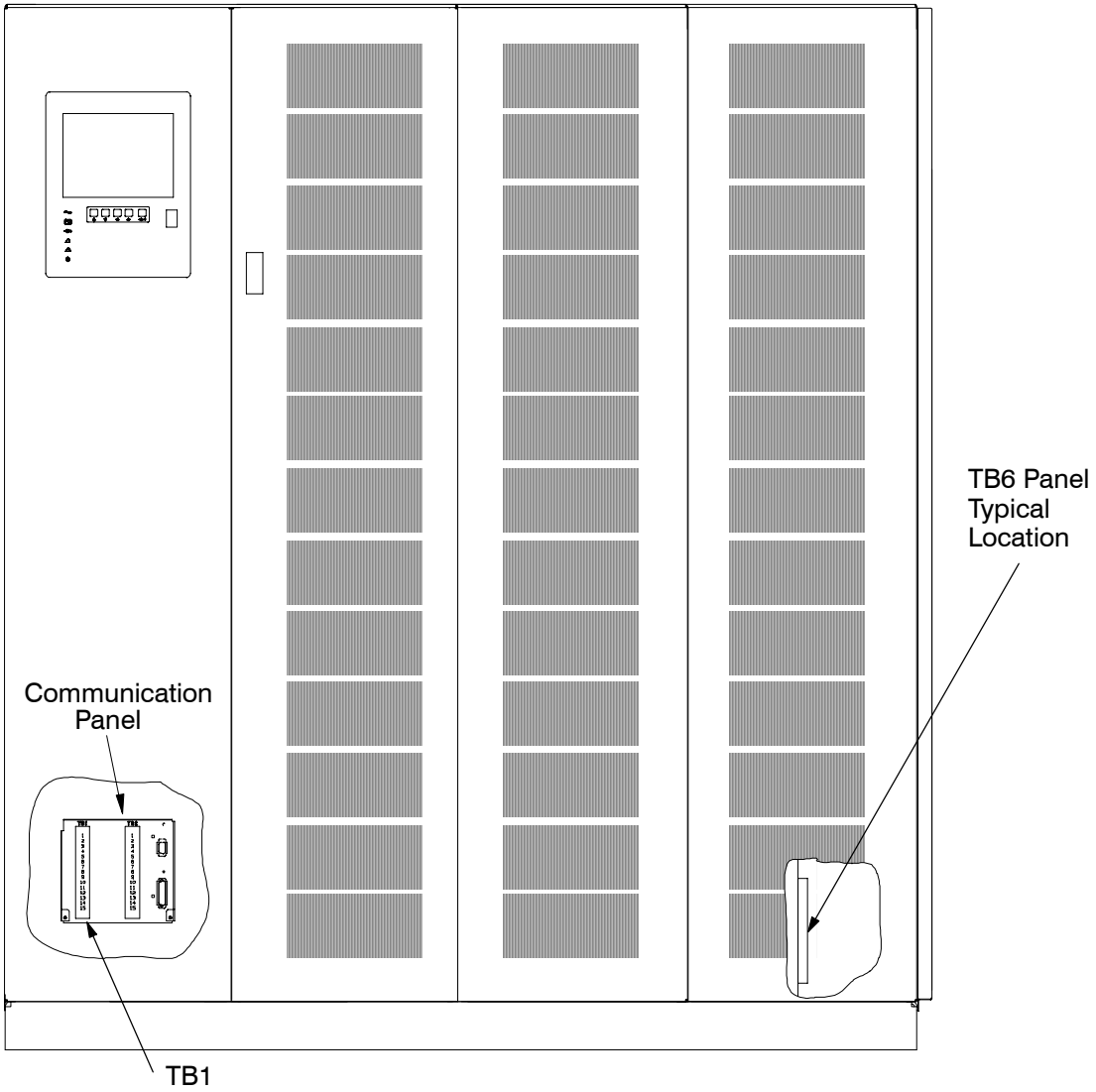

Figure 4. Powerware Sync Control Interface Locations for 200–300 kVA Single Module Powerware 9315 UPS System

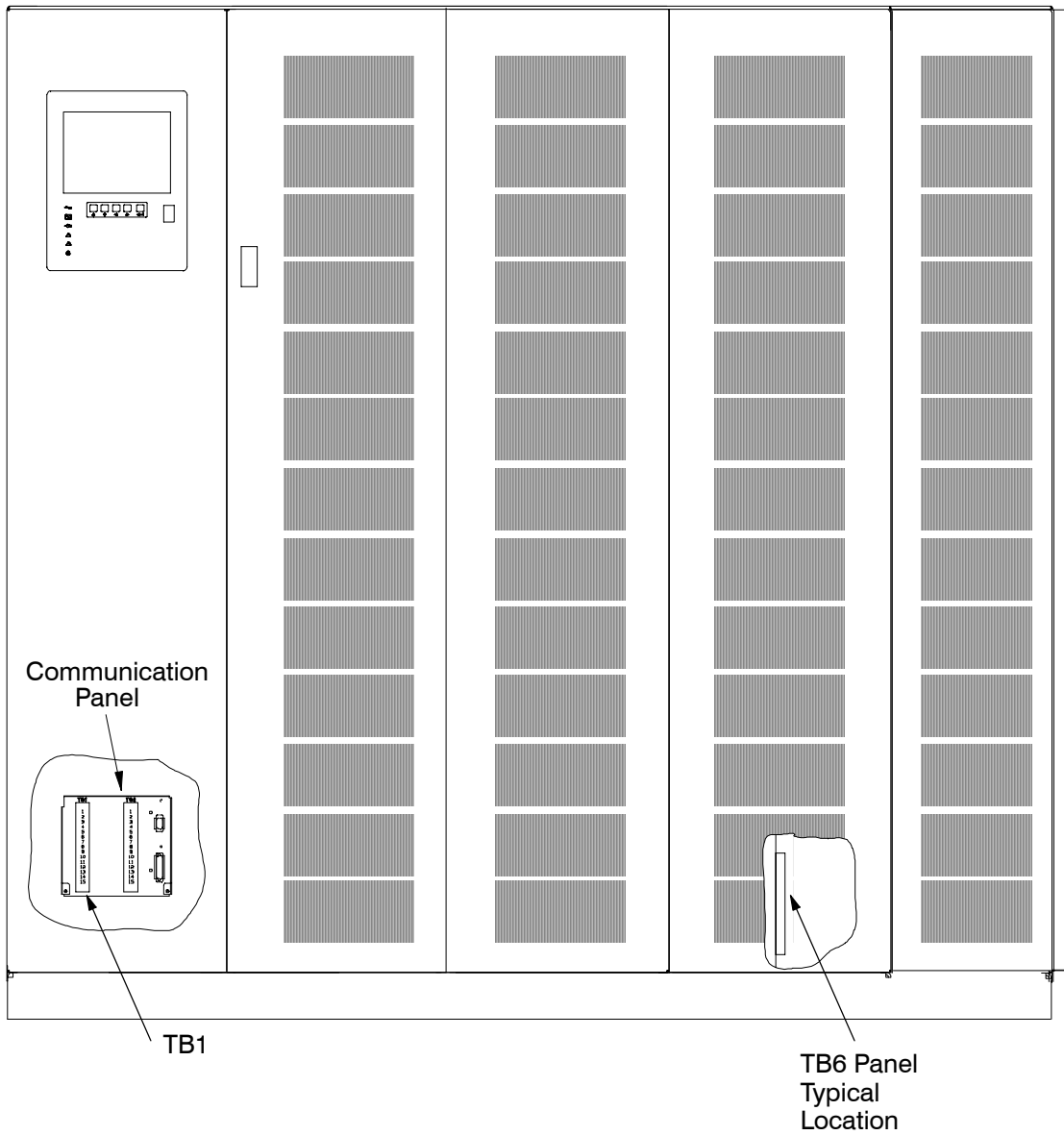
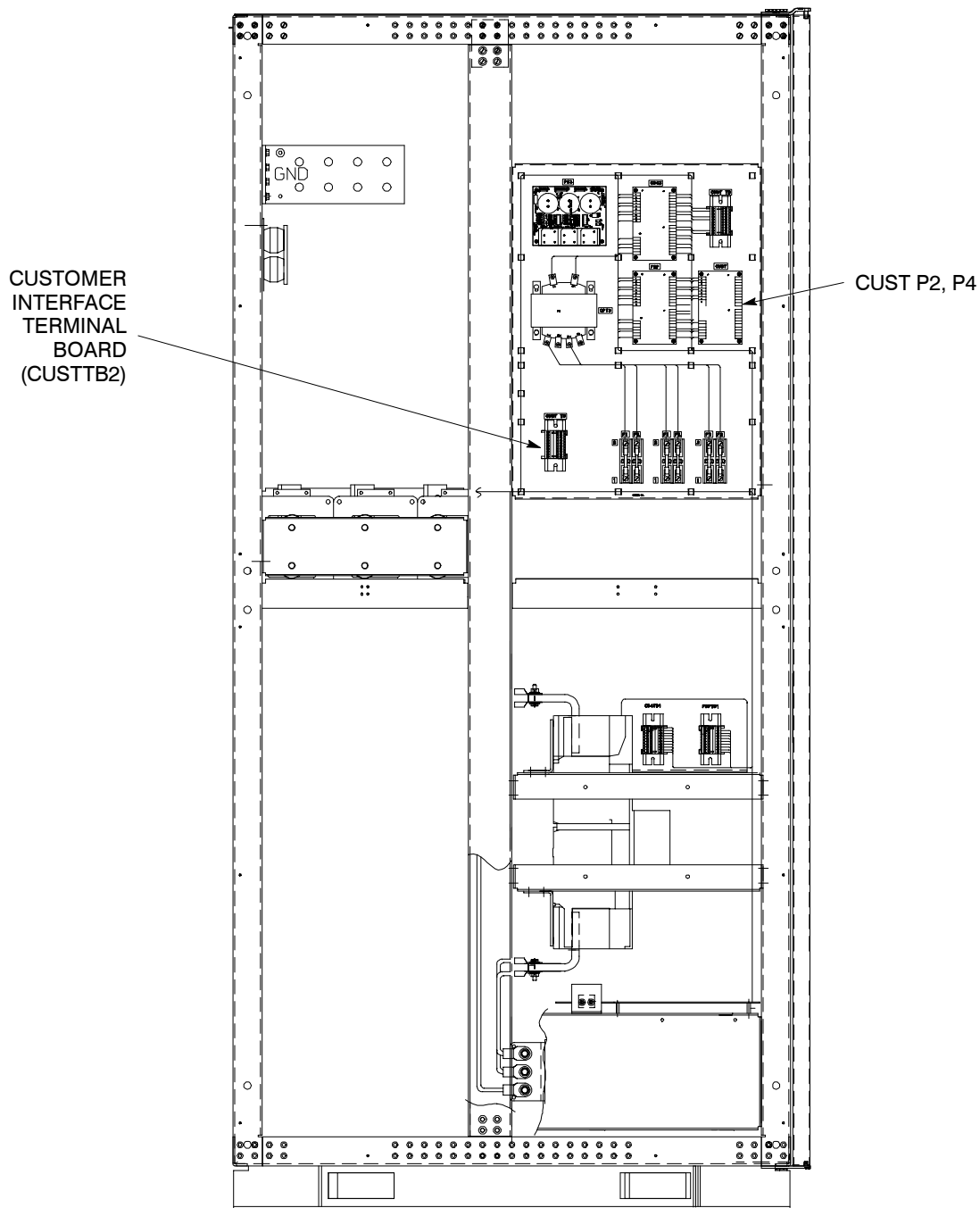
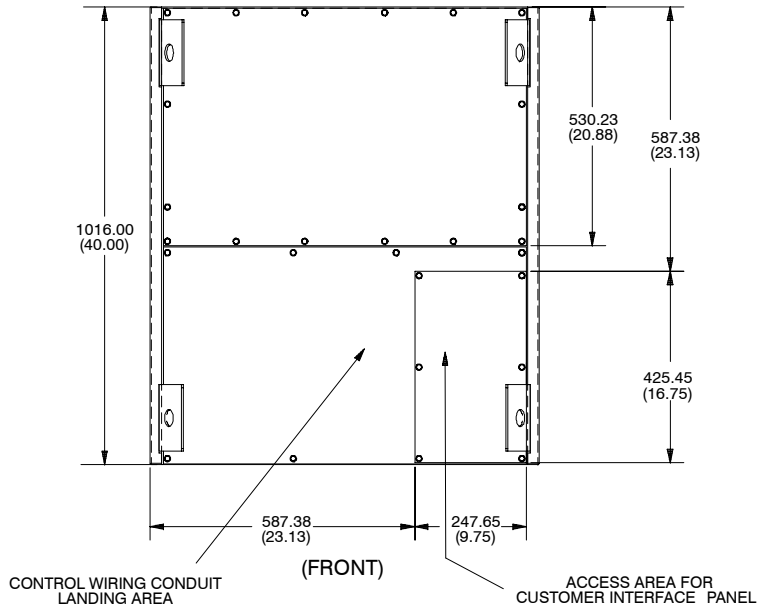

Figure 5. Powerware Sync Control Interface Location for 400–500 kVA Single Module Powerware 9315 UPS System



Left Side View, Reverse Transfer Cabinet (MBC)

Figure 6. Powerware Sync Control Interface Location for 750 kVA Single Module Powerware 9315 UPS System



TOP EXTERIOR VIEW

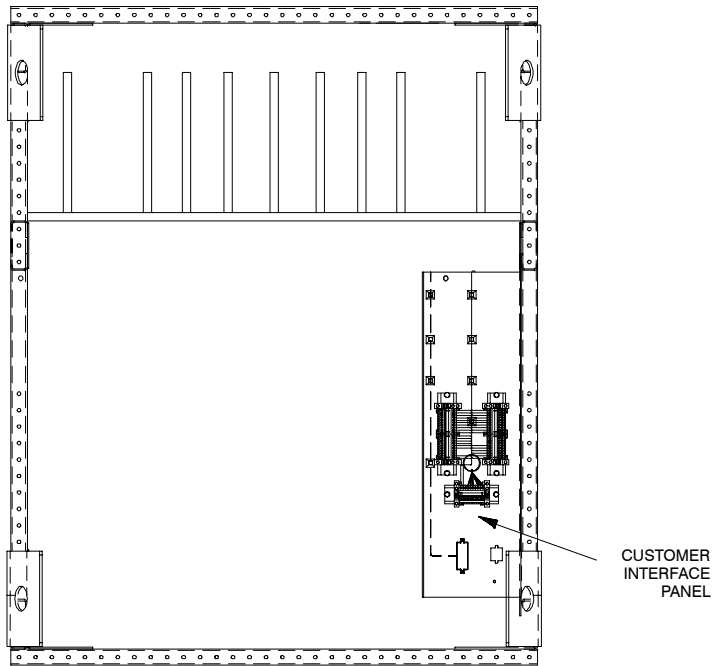

(FRONT)
TOP INTERIOR VIEW

Figure 7. Powerware Sync Control Interface Location for Powerware Hot Sync – Capacity System with 1200 Amp SBM

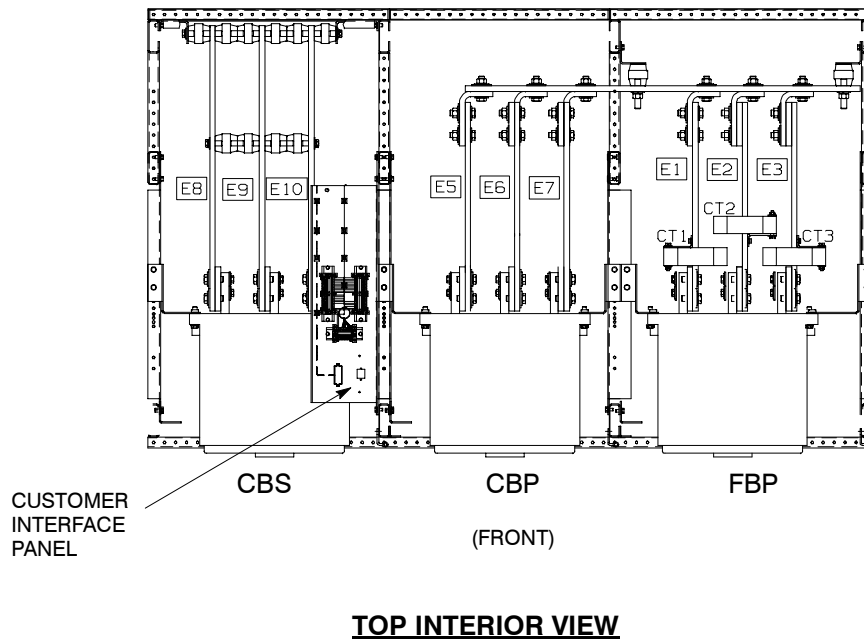
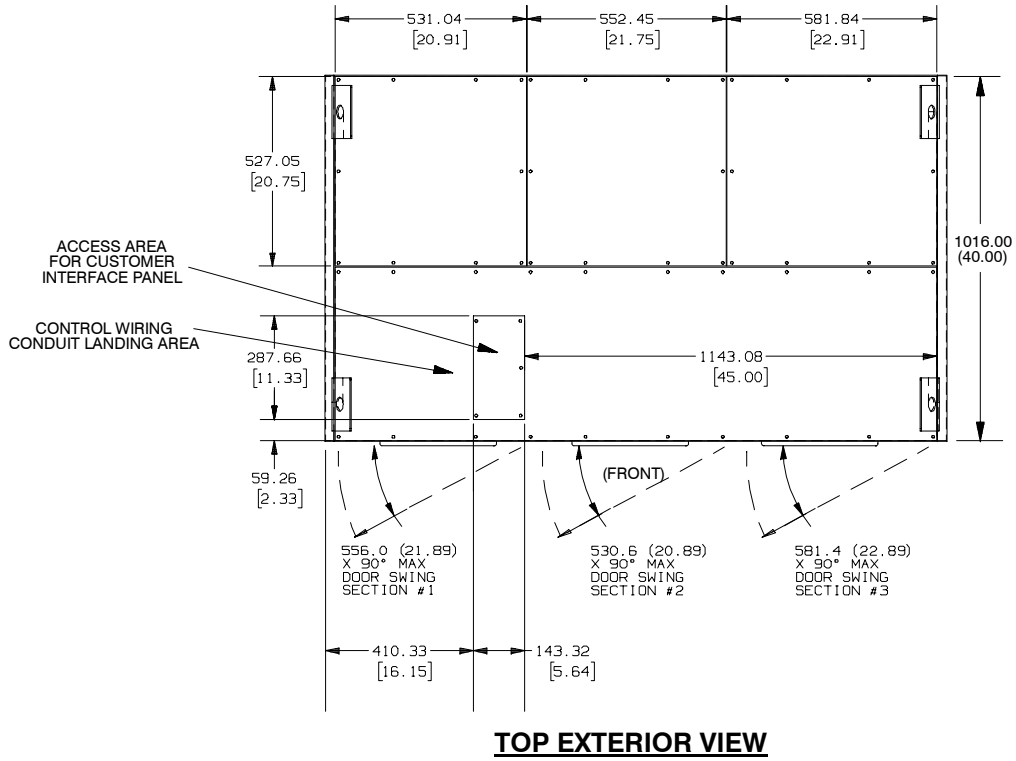

Figure 8. Powerware Sync Control Interface Location for Powerware Hot Sync – Capacity System with 2000 Amp SBM

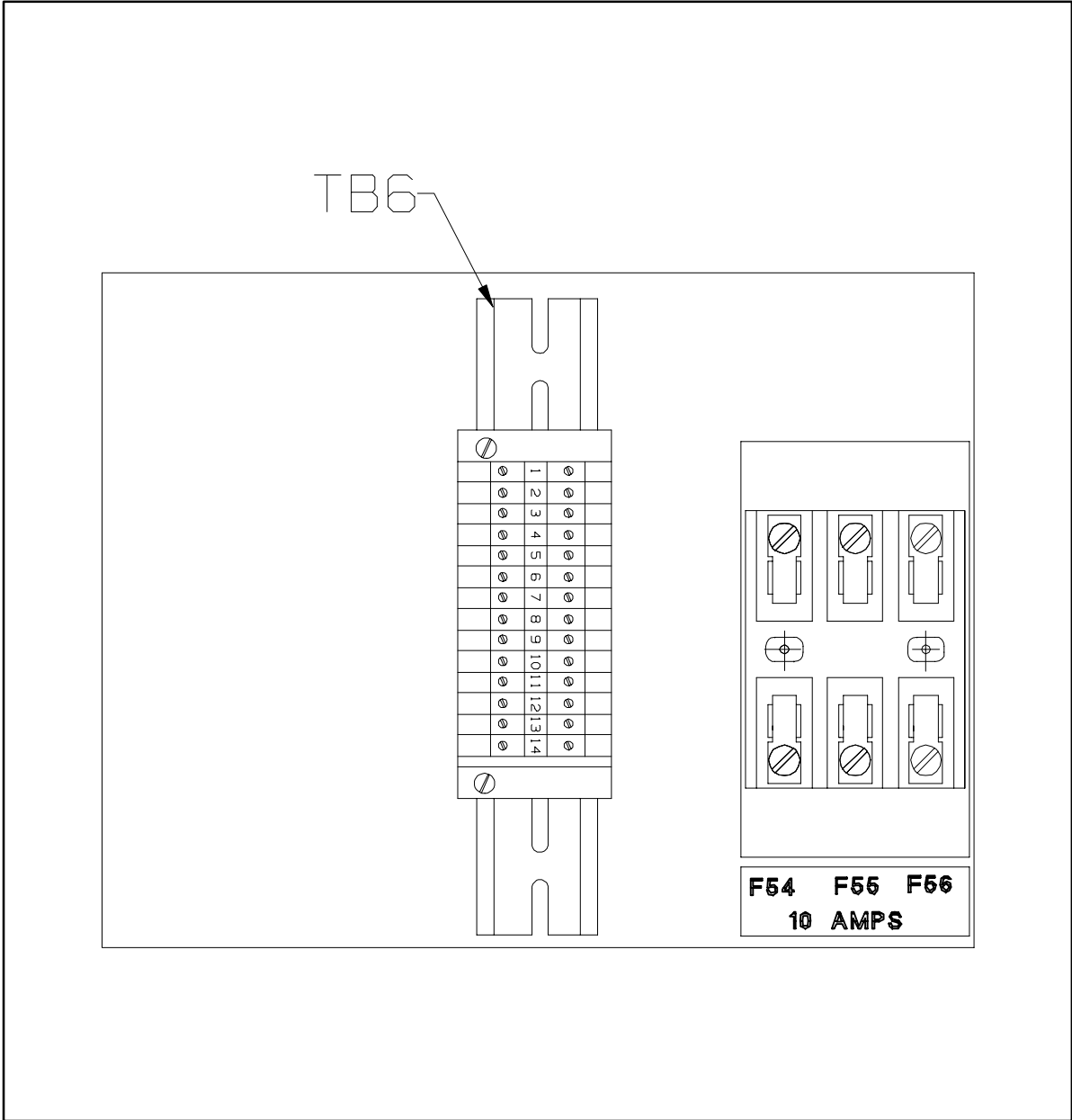
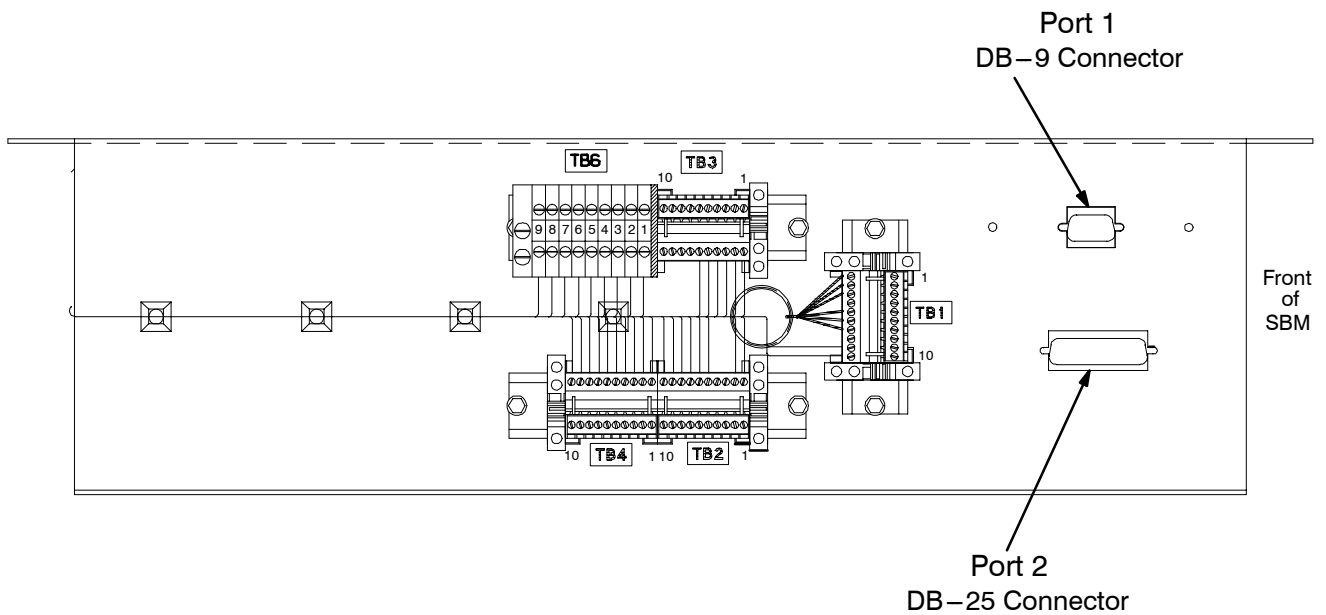

Figure 9. Typical Powerware Sync Control TB6 Terminal Block Located in Powerware 9315 UPS Module



**1200 and 2000 Amp SBM
Customer Interface Panel
Top View**

Figure 10. Location of SBM Customer Interface Panel Terminal Blocks TB3, TB4, and TB6

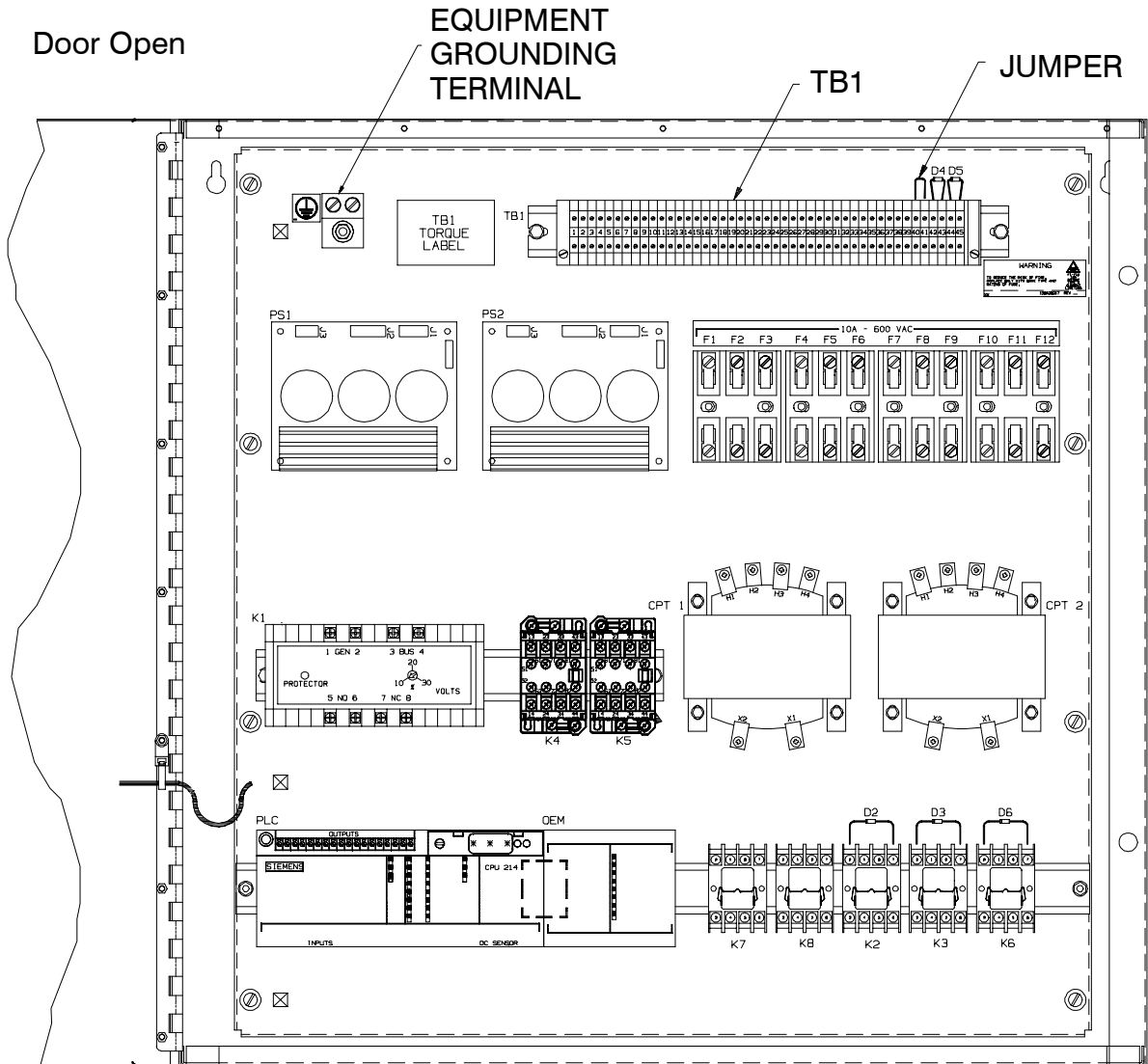

Figure 11. Typical Control Wiring Termination Locations for the Powerware Sync Control

This Page Intentionally Left Blank.

3

Powerware Sync Control Operation

This chapter describes the operation of the Powerware Sync Control with an UPS or SBM system.

Preliminary Checks and Startup for UPS or SBM Systems Equipped with a Powerware Sync Control

Installation inspection and startup procedures must be performed only by an authorized service person. The procedure is normally part of the sales contract for the UPS or SBM system.

WARNING:

Attempts to startup the UPS or SBM system yourself may damage equipment and/or your critical load. Such attempts may also invalidate your system warranty.

CAUTION:

As shipped, the Powerware Sync Control is setup for operation with a Powerware Hot Sync–Capacity system. For operation with a single module Powerware 9315 UPS system, the jumper between terminal points TB1–40 and TB1–41 must be removed. Removal of this jumper must be performed by an authorized service person. Removal or installation of this jumper by anyone but an authorized service person may damage the equipment and/or critical load and void the warranty.

Understanding Sync Control Operation

The Powerware Sync Control maintains critical load synchronization of two single Powerware 9315 module systems or two Powerware Hot Sync–Capacity systems. See Figures 12 and 13 for a typical block diagram of the systems. This facilitates the uninterrupted transfer of customer loads from one load bus to another by means of downstream dual source solid state transfer switches. The automatic synchronization action of the Powerware Sync Control panel is enabled by pressing the **LOAD SYNC ENABLE** pushbutton on the front of the panel. When enabled, the **LOAD SYNC ENABLE** pushbutton lamp will illuminate.

The Powerware Sync Control panel provides a three phase synchronization reference to each system. Each system uses this reference to regulate the inverter phase relationship so that the two system outputs can maintain synchronization with each other. To establish the three phase synchronization reference, each system provides bypass sensing voltage and output (critical load) bus voltage to the Powerware Sync Control.

Under normal operating conditions, bypass sensing voltage from each system is provided back to its inverter through the Powerware Sync Control. As long as the two bypass sources feeding System–A and System–B are available and in phase, each system remains in synchronization with its own bypass source and the two systems remain in synchronization with each other. If the two bypass sources become out of phase with each other (> 0.1 HZ apart) or one or both sources become unavailable, the Powerware Sync Control will provide a new three phase synchronization reference to the slave system as determined by the **PREFERRED SOURCE SELECTOR** switch S1. The slave system's new synchronization reference is provided by the Powerware Sync Control from the output (critical load) bus of the system designated as master by **PREFERRED SOURCE SELECTOR** switch S1. See Figure 14 for a pictorial representation of the synchronization reference control.

When the two bypass sources regain availability and synchronization, the Powerware Sync Control provides the slave system with its own bypass sensing voltage as a synchronization reference. Before re-synchronization occurs, a fifteen second preset time delay has been provided to ensure the two bypass sources maintain acceptable synchronization.

In order to maintain a fault tolerant arrangement, fault conditions or abnormal operating conditions are accounted for in the Powerware Sync Control. The main provisions are listed below:

- 1 An automatic reassignment of the preferred source (master) is made if the slave system goes to bypass, regardless of the position of **PREFERRED SOURCE SELECTOR** switch S1. When the slave system (as defined by S1) is on bypass, the slave system automatically becomes the master. The two systems will continue to synchronize to their own bypass source until one of the bypass sources become unavailable or the two bypass sources are no longer in synchronization with each other.
- 2 If one UPS system loses its critical load bus voltage sensing, each system synchronizes to its own bypass source regardless of the position of the **PREFERRED SOURCE SELECTOR** switch S1
- 3 Dual redundant logic power supplies are incorporated within the Powerware Sync Control, ensuring both systems remain synchronized even during the loss of one of the logic power supplies. These power supplies are powered from each system's critical load bus.
- 4 With a complete loss of logic power to the Powerware Sync Control (due to either component failure or power supply fault), each system synchronizes to its own bypass source.

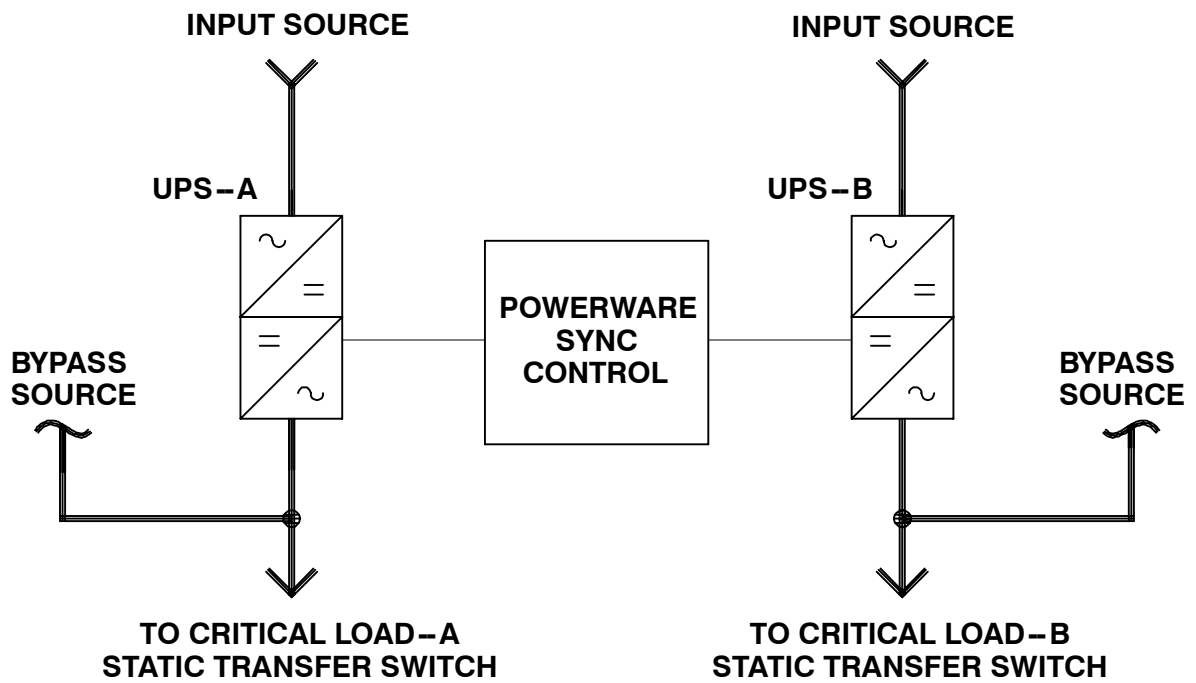

Figure 12. Typical Powerware Sync Control Block Diagram for a Single Module Powerware 9315 UPS System

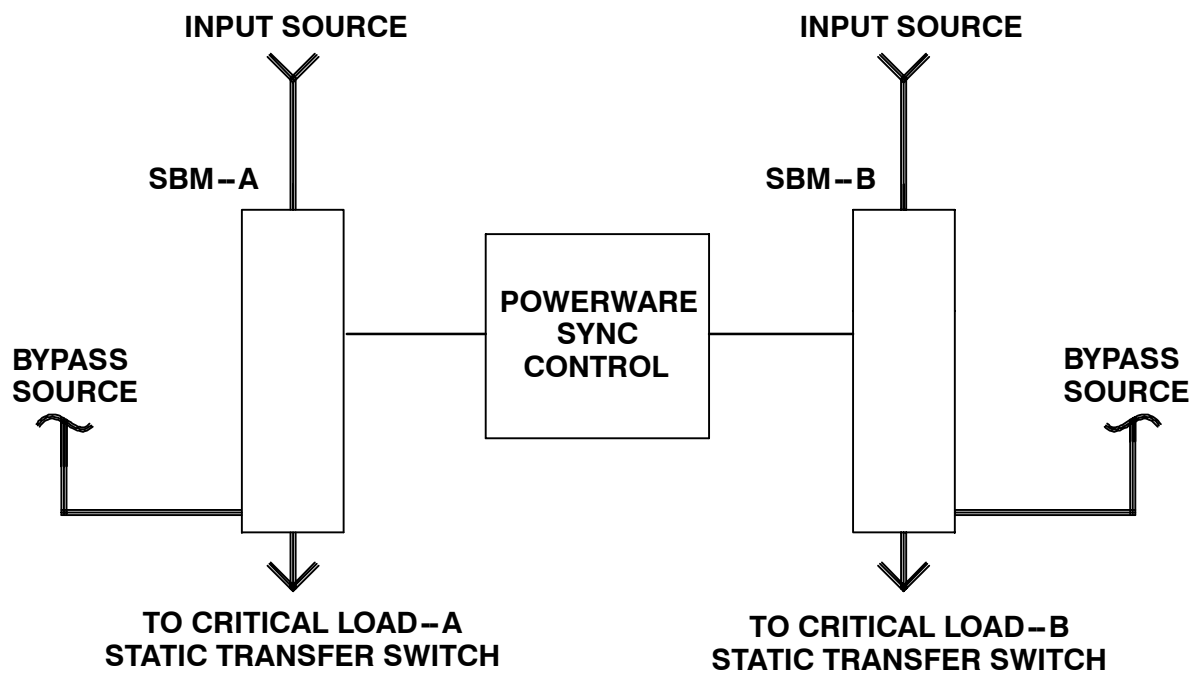
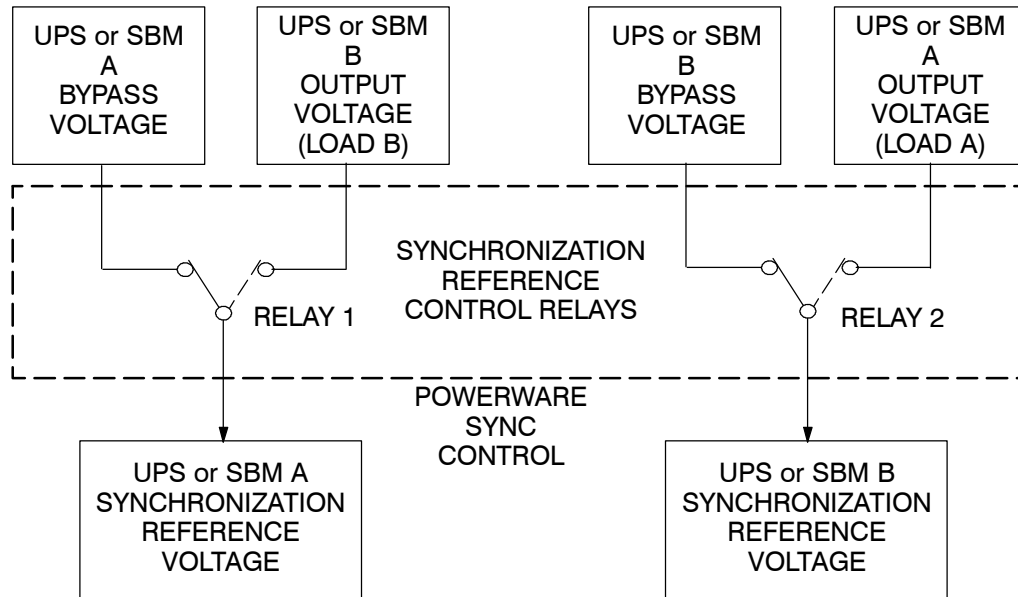

Figure 13. Typical Powerware Sync Control Block Diagram for a Powerware Hot Sync-Capacity System



- NOTES:
1. The Synchronization Reference Control relays, are shown under normal conditions. Both bypass sources are available and are in synchronization.
 2. Dashed switch position of Synchronization Reference Control Relay 1 shows UPS or SBM system A in the slave system mode.
 3. Dashed switch position of Synchronization Reference Control Relay 2 shows UPS or SBM system B in the slave system mode.
 4. At any given time, only one of the UPS or SBM systems can be in the slave system mode.

Figure 14. Synchronization Reference Control

Operation

Perform the following procedures to set up the Powerware Sync Control for operation with your system. Refer to Figure 15 and Table 1 for the location and explanation of the controls and indicators on the Powerware Sync Control.

1. Place both UPS or SBM systems in normal operating mode in accordance with the procedures in the applicable operations manual supplied with the system (refer to the *Introduction* in this manual for manual part numbers).
2. Depress the **LAMP TEST** pushbutton switch to verify all indicators illuminate and are working correctly.
3. Determine which system load bus (A or B) will be used as the master synchronization source. Set the **PREFERRED SOURCE SELECTOR** switch to this load bus.

NOTE: If either of the yellow **SYNCHRONIZED TO LOAD** indicators are illuminated, the **PREFERRED SOURCE SELECTOR** switch is locked out and the master synchronization source can not be changed.

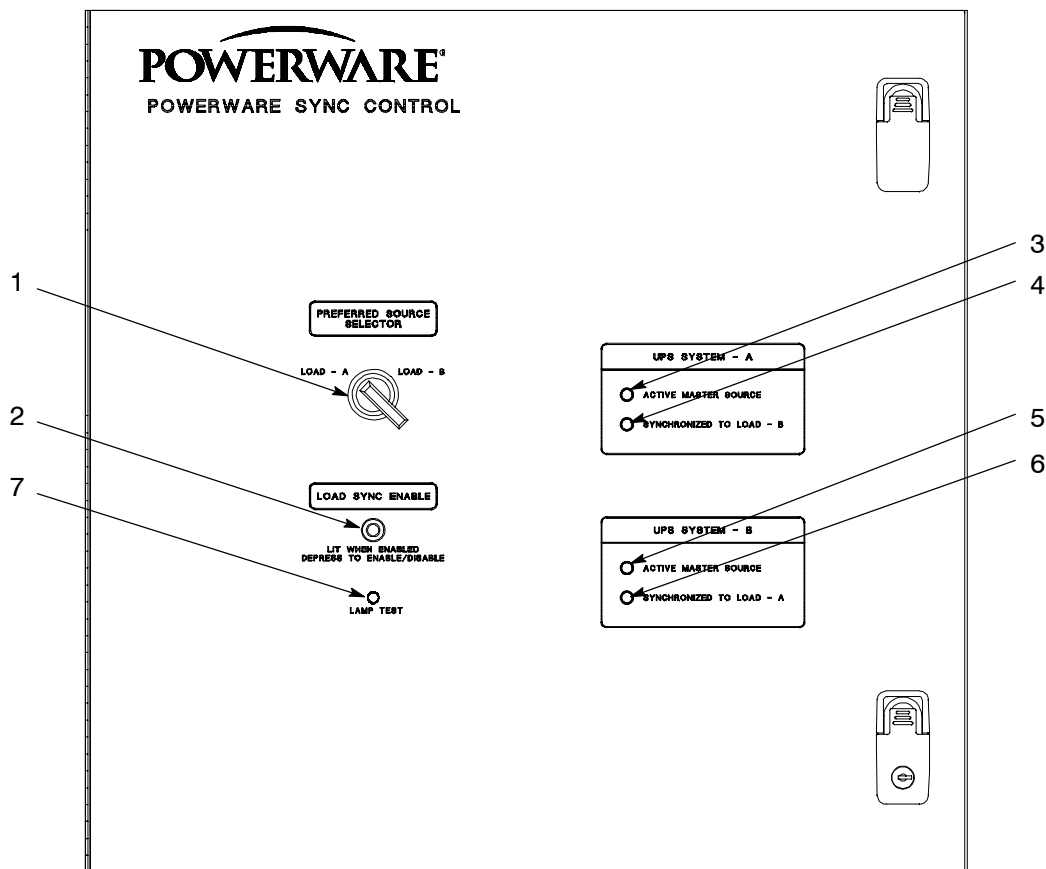

Figure 15. Powerware Sync Control Controls and Indicators

Table 1. Controls and Indicators		
Item	Name	Function and Description
1	PREFERRED SOURCE SELECTOR	Two position rotary switch allowing either of the two system load buses to be assigned as the master sync source.
2	LOAD SYNC ENABLE	Enables or disables the automatic Powerware Sync Control unit. Switch is illuminated when load sync action is enabled.
3	UPS SYSTEM – A ACTIVE MASTER SOURCE	When illuminated, indicates system A is the active master source. This indicator may illuminate even if the PREFERRED SOURCE SELECTOR switch position is not set to the corresponding position.
4	UPS SYSTEM – A SYNCHRONIZED TO LOAD – B	When illuminated, indicates that system A is in the slave system mode and is synchronized to the system B load bus.
5	UPS SYSTEM – B ACTIVE MASTER SOURCE	When illuminated, indicates system B is the active master source. This indicator may illuminate even if the PREFERRED SOURCE SELECTOR switch position is not set to the corresponding position.
6	UPS SYSTEM – B SYNCHRONIZED TO LOAD – A	When illuminated, indicates that system B is in the slave system mode and is synchronized to the system A load bus.
7	LAMP TEST	Pushbutton illuminates all lamps on the Powerware Sync Control unit for visual testing.

- Depress the **LOAD SYNC ENABLE** pushbutton switch to enable the automatic synchronization control. The pushbutton illuminates when the synchronization control is activated.

NOTE: *If both systems are operating normally, the **ACTIVE MASTER SOURCE** green indicator illuminates for the selected master synchronization source.*

*If one system is in bypass, the **ACTIVE MASTER SOURCE** green indicator illuminates for the system in bypass, regardless of the position of the **PREFERRED SOURCE SELECTOR** switch.*

*If, during operation, one or both of the systems lose their bypass sources or if the bypass sources are no longer in synchronization, the yellow **SYNCHRONIZED TO LOAD** indicator illuminates for the slave system.*

- To disable the automatic synchronization control, depress the **LOAD SYNC ENABLE** pushbutton switch and verify indicators, including the **LOAD SYNC ENABLE** pushbutton, are extinguished.

Customer Monitoring

The operating status of the Powerware Sync Control is available for the Customer's remote monitoring system using dry relay contacts connected to the TB1 terminal strip. Refer to Table 3 in Appendix A for wiring details. Status of the following Powerware Sync Control conditions are provided:

- UPS System A Active Master Source
- UPS System B Active Master Source
- UPS System A Synchronized to Load B
- UPS System B Synchronized to Load A
- Load Sync Enabled

An alarm for Sync Control Trouble from the Powerware Sync Control is provided to each UPS or SBM system as Building Alarm number 4. The alarm is activated for the following conditions:

- Failure of one or both power supplies
- PLC Mode switch in STOP position
- PLC shutdown due to fatal program error.

If the Sync Control Trouble alarm activates, contact Customer Service.

NOTE: *If either System – A or System – B are taken out of service for maintenance, voltage input to one of the power supplies is lost, and the Sync Control Trouble alarm activates. The alarm clears when the UPS or SBM system is placed back into service and Customer Service need not be contacted.*

Maintenance Operations

CAUTION:

Refer to the applicable manual before beginning maintenance or repairs on the UPS or SBM equipment:

- Chapter 9 – *Maintaining the UPS System* of the Powerware 9315 30–160kVA Operation manual, Powerware Corporation part number 164200252
- Chapter 9 – *Maintaining the UPS System* of the Powerware 9315 200–300kVA Operation manual, Powerware Corporation part number 164201036
- Chapter 9 – *Maintaining the UPS System* of the Powerware 9315 200–300kVA Operation manual, Powerware Corporation part number 164201119
- Chapter 15 – *Maintaining the Parallel Capacity/Redundant System* of the Powerware 9315 Parallel Capacity/Redundant System Installation and Operation manual, Powerware Corporation part number 164201150
- Chapter 17 – *Maintaining the UPS System* of the Powerware 9315 500–750kVA Installation and Operation manual, Powerware Corporation part number 164201244

Maintenance should be scheduled on a periodic basis, recommended not to exceed one year. More frequent intervals are recommended if the equipment is subjected to highly repetitive operations.

WARNING:

Dangerous and life-threatening voltages are present when the UPS or SBM is operating. De-energize all equipment before physically touching potentially live parts.

Periodic inspections of the Powerware Sync Control should be made to determine if components, wiring, and connections exhibit evidence of overheating or damage.

This Page Intentionally Left Blank.

Appendix A – Customer Information

The information in this appendix will help you plan for and install your Powerware System Load Sync Control. This appendix contains the following drawings:

- 164201140–1 Typical Powerware Sync Control
- 164201140–2 Powerware Sync Control Interface Location for Single Module Powerware 9315 UPS System (30–750kVA)
- 164201140–3 Powerware Sync Control Interface Location for Powerware Hot Sync – Capacity System with 1200 Amp SBM
- 164201140–4 Powerware Sync Control Interface Location for Powerware Hot Sync – Capacity System with 2000 Amp SBM
- 164201140–5 SBM Customer Interface Panel
- 164201140–6 Oneline Drawing of Typical Single Module Powerware 9315 UPS System
- 164201140–7 Oneline Drawing of Typical Powerware Hot Sync – Capacity System
- 164201140–8 Installation Notes
- 164201140–9 Table 1 – Single Module Powerware 9315 UPS System Control Wiring Interconnections (30–750kVA)
- 164201140–10 Table 2 – Powerware Hot Sync – Capacity System Control Wiring Interconnections
- 164201140–11 Table 3 – Customer Remote Monitoring System Wiring Interconnections
- 164201140–12 Simplified Single Module UPS System Oneline
- 164201140–13 Simplified Powerware Hot Sync – Capacity System Oneline

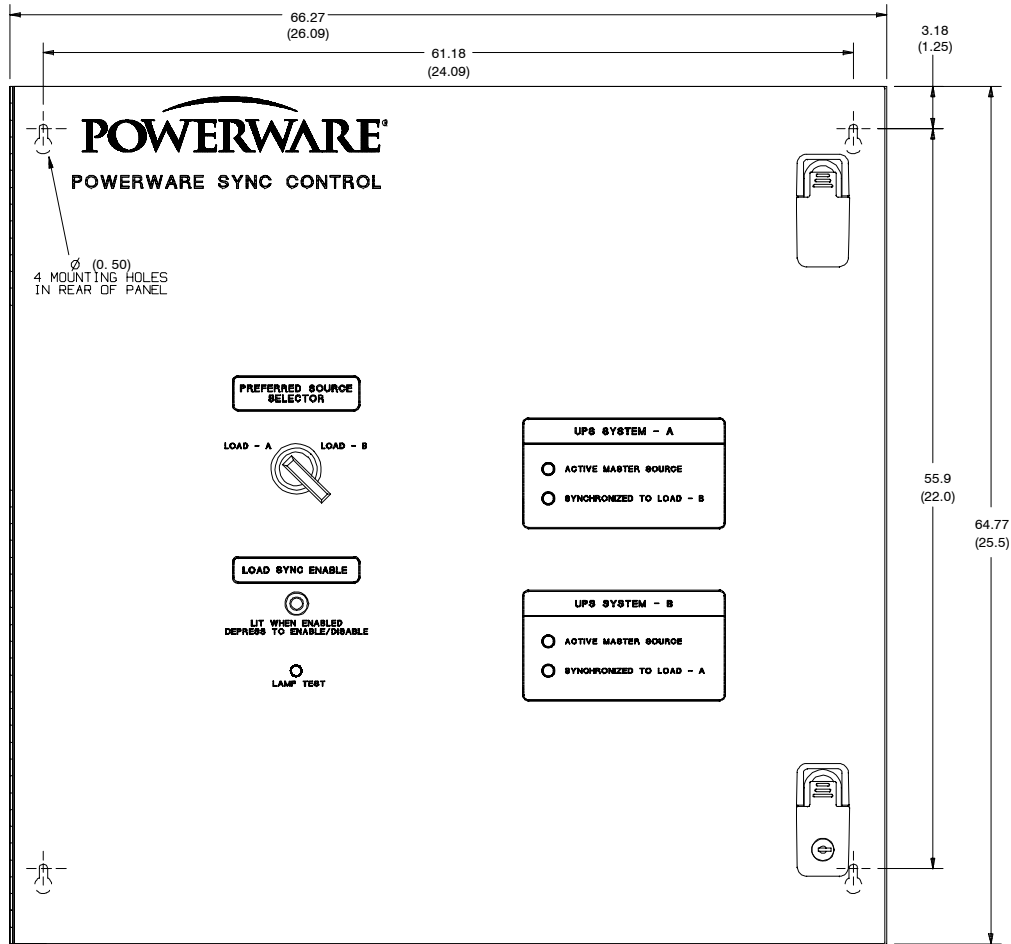

FRONT VIEW

All dimensions are in centimeters (inches)

DESCRIPTION: TYPICAL POWERWARE SYNC CONTROL		
DRAWING NO:	164201140-1	SHEET: 1 of 3
REVISION: E	DATE: 021500	

**KNOCKOUT
HOLES FOR 1
INCH CONDUIT**

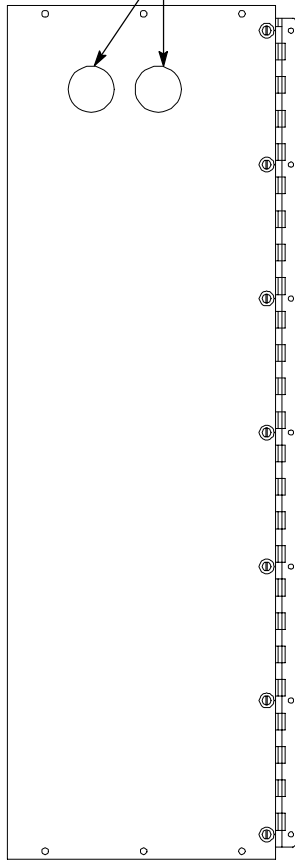

LEFT SIDE VIEW

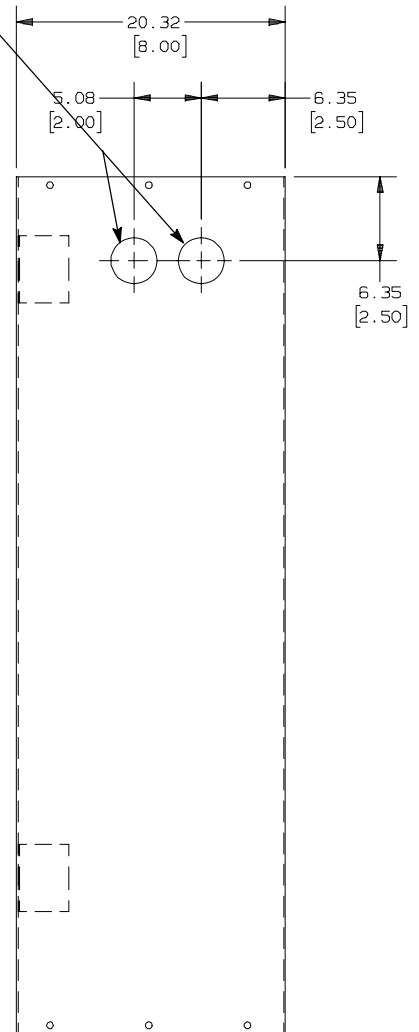

RIGHT SIDE VIEW

All dimensions are in centimeters (inches)

<i>DESCRIPTION:</i> TYPICAL POWERWARE SYNC CONTROL	
<i>DRAWING NO:</i> 164201140-1	<i>SHEET:</i> 2 of 3
<i>REVISION:</i> C	<i>DATE:</i> 103098

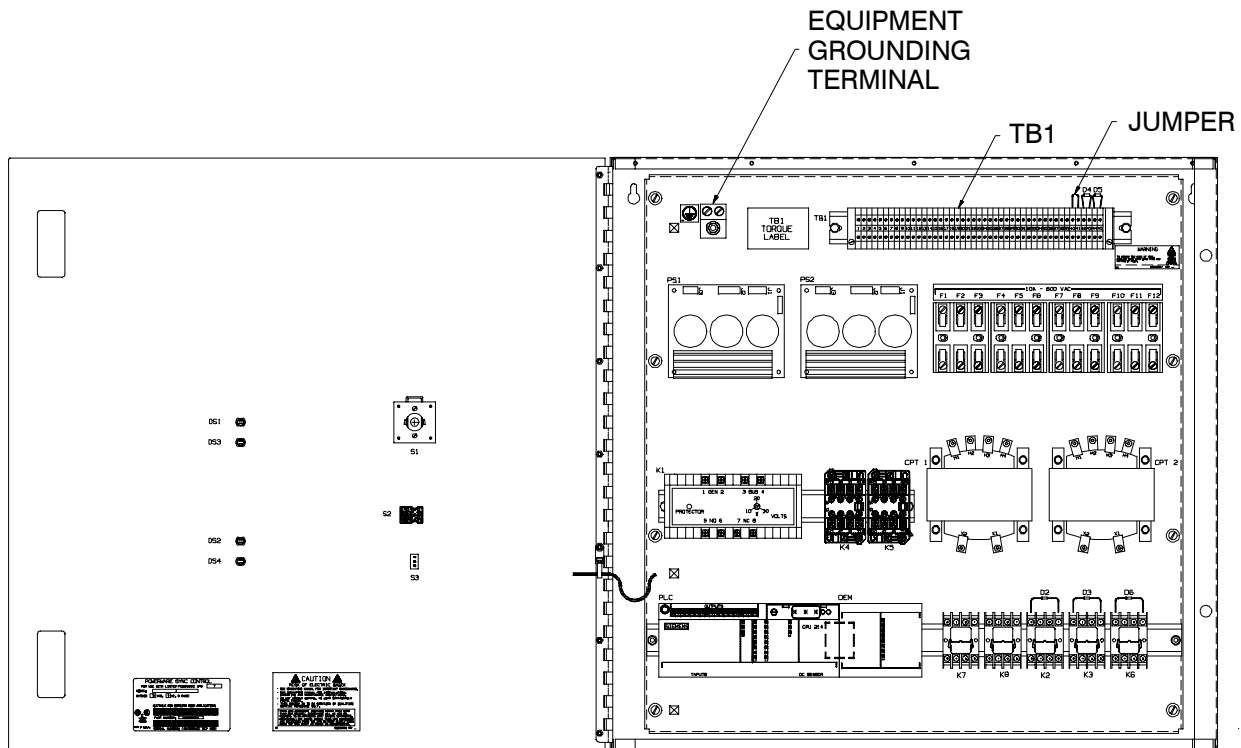

POWERWARE SYNC CONTROL ENCLOSURE

FRONT VIEW WITH DOOR OPEN

CAUTION:

As shipped, the Powerware Sync Control is setup for operation with a Powerware Hot Sync–Capacity system. For operation with a single module Powerware 9315 UPS system, the jumper between terminal points TB1–40 and TB1–41 must be removed. Removal of this jumper must be performed by an authorized service person. Removal or installation of this jumper by anyone but an authorized service person may damage the equipment and/or critical load and void the warranty.

DESCRIPTION: TYPICAL POWERWARE SYNC CONTROL		
DRAWING NO:	164201140–1	SHEET: 3 of 3
REVISION: D	DATE: 010199	

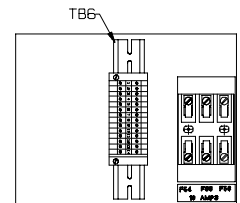
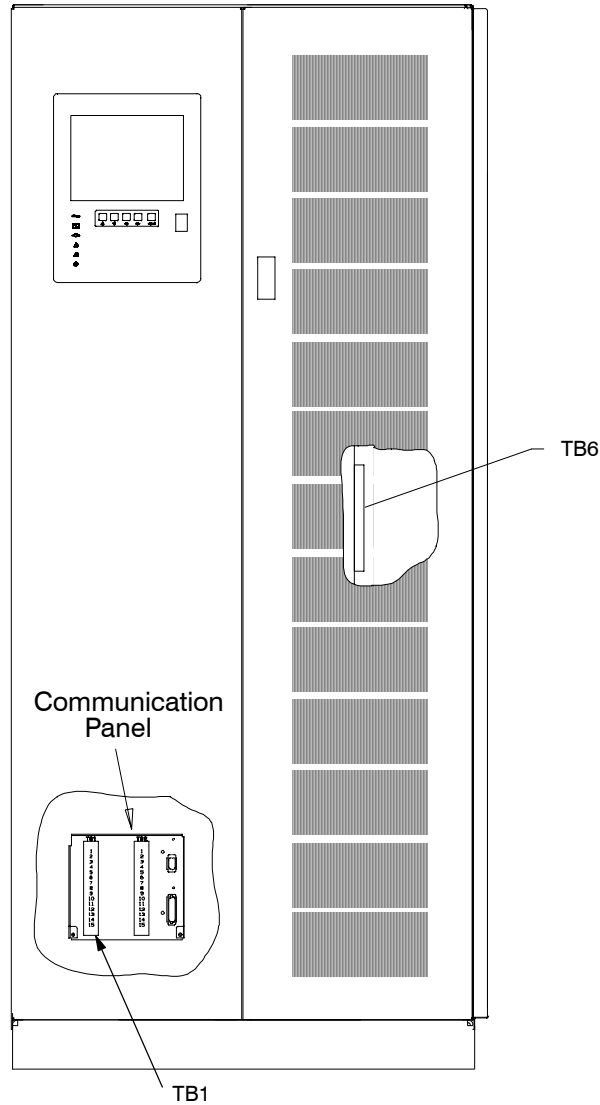

VIEW A-A

POWERWARE 9315
MODEL 30 – 80 KVA

DESCRIPTION: POWERWARE SYNC CONTROL INTERFACE LOCATION FOR SINGLE MODULE POWERWARE 9315 UPS SYSTEM		
DRAWING NO:	164201140-2	SHEET: 1 of 5
REVISION:	E	DATE: 021599

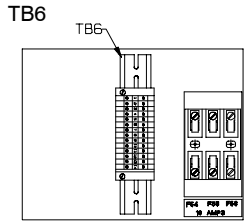
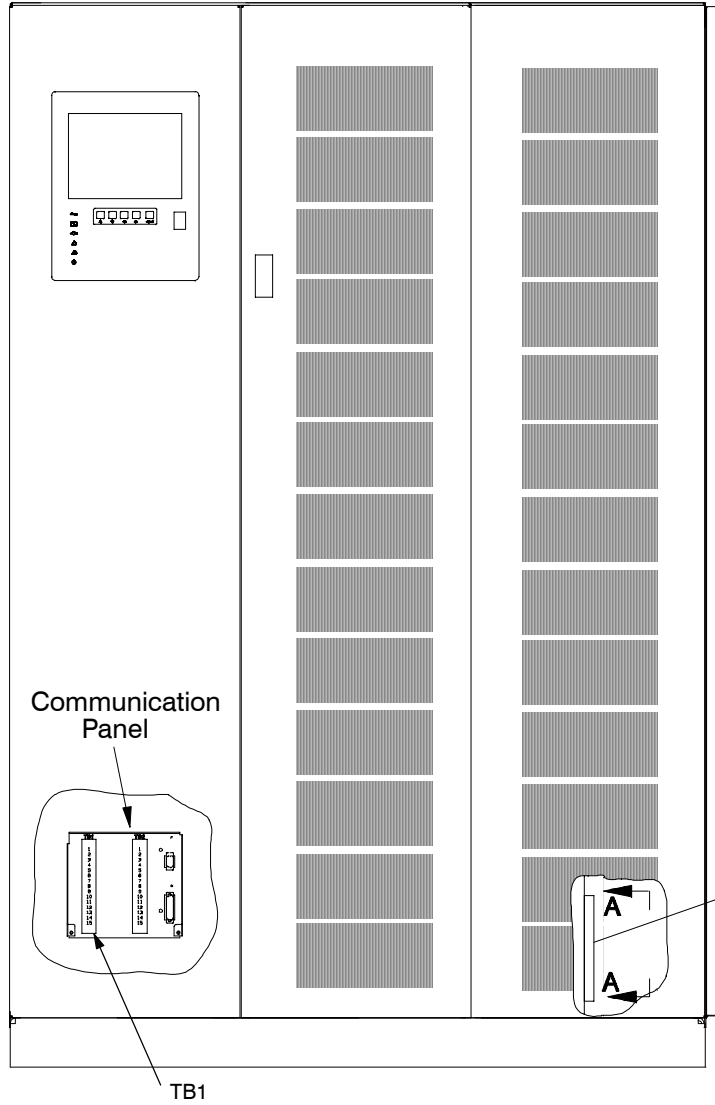

VIEW A-A

POWERWARE 9315
MODEL 100 – 160 KVA

<i>DESCRIPTION:</i> POWERWARE SYNC CONTROL INTERFACE LOCATION FOR SINGLE MODULE POWERWARE 9315 UPS SYSTEM		
<i>DRAWING NO:</i>	164201140-2	<i>SHEET:</i> 2 of 5
<i>REVISION:</i>	E	<i>DATE:</i> 021500

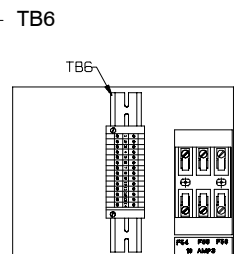
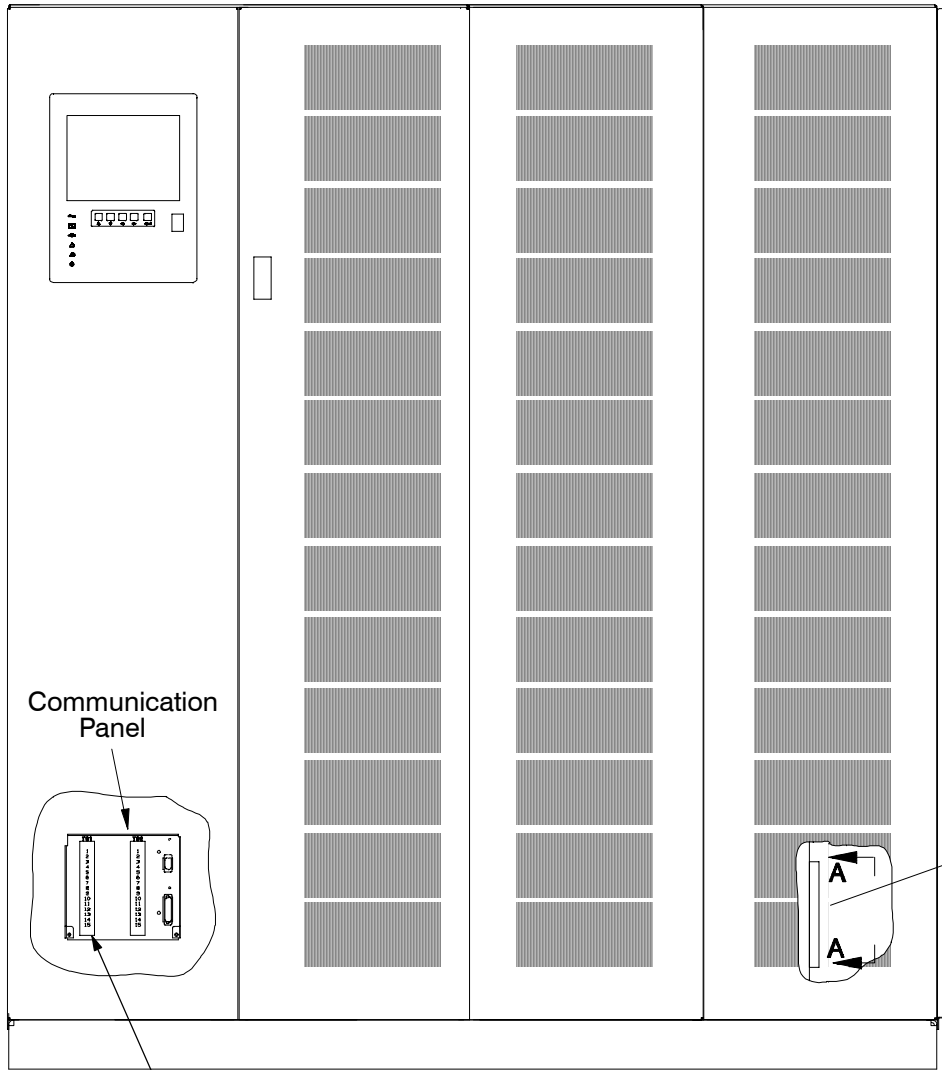

POWERWARE 9315
MODEL 200 – 300 KVA

DESCRIPTION: POWERWARE SYNC CONTROL INTERFACE LOCATION FOR SINGLE MODULE POWERWARE 9315 UPS SYSTEM		
DRAWING NO:	164201140-2	SHEET: 3 of 5
REVISION:	E	DATE: 021500

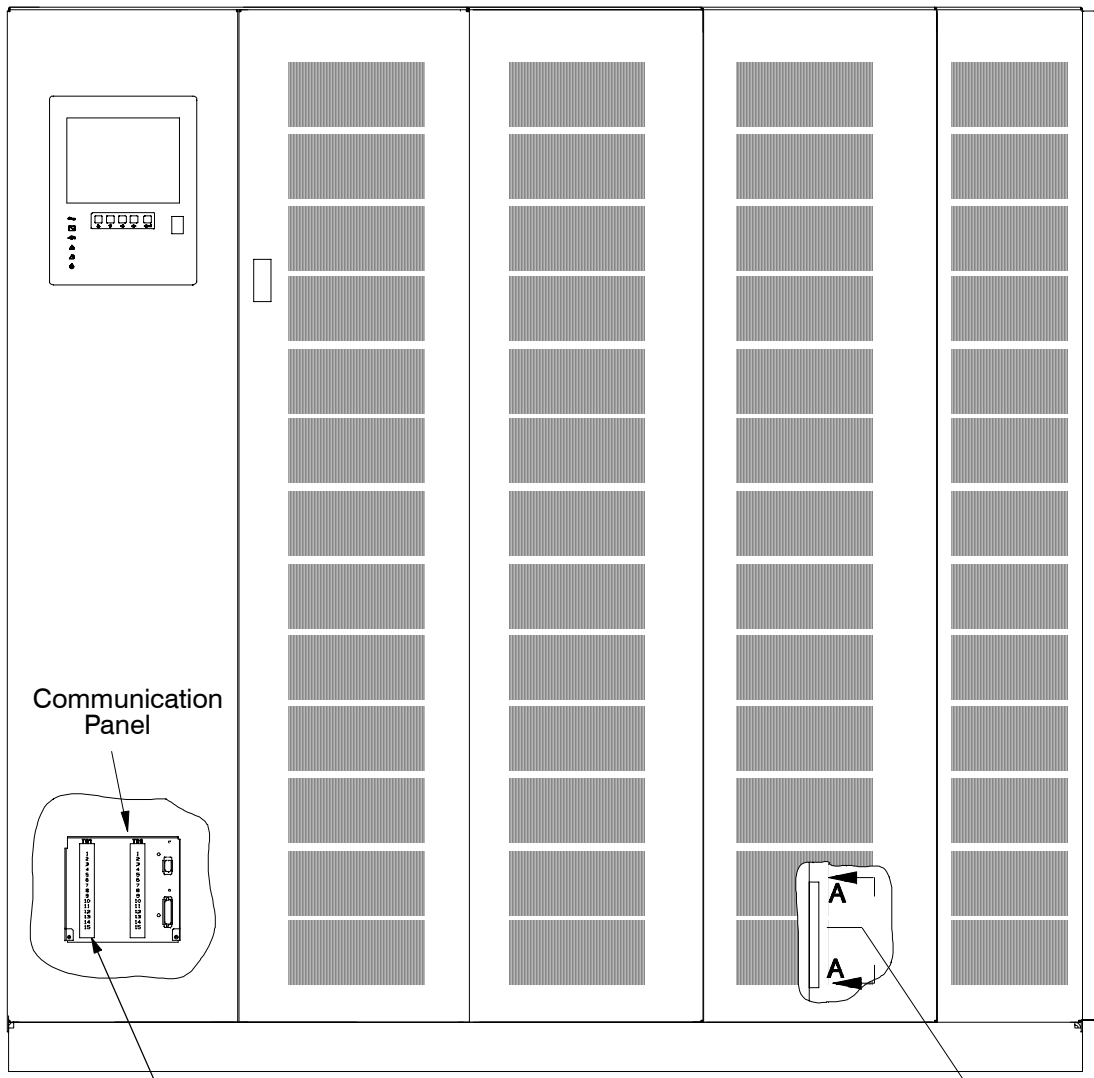

Communication Panel

TB1

TB6

POWERWARE 9315
MODEL 400 – 500 KVA

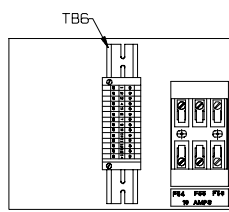

VIEW A-A

DESCRIPTION: POWERWARE SYNC CONTROL INTERFACE LOCATION FOR SINGLE MODULE POWERWARE 9315 UPS SYSTEM		
DRAWING NO:	164201140-2	SHEET: 4 of 5
REVISION:	E	DATE: 021500

CUSTOMER
INTERFACE
TERMINAL
BOARD
(CUSTTB2)

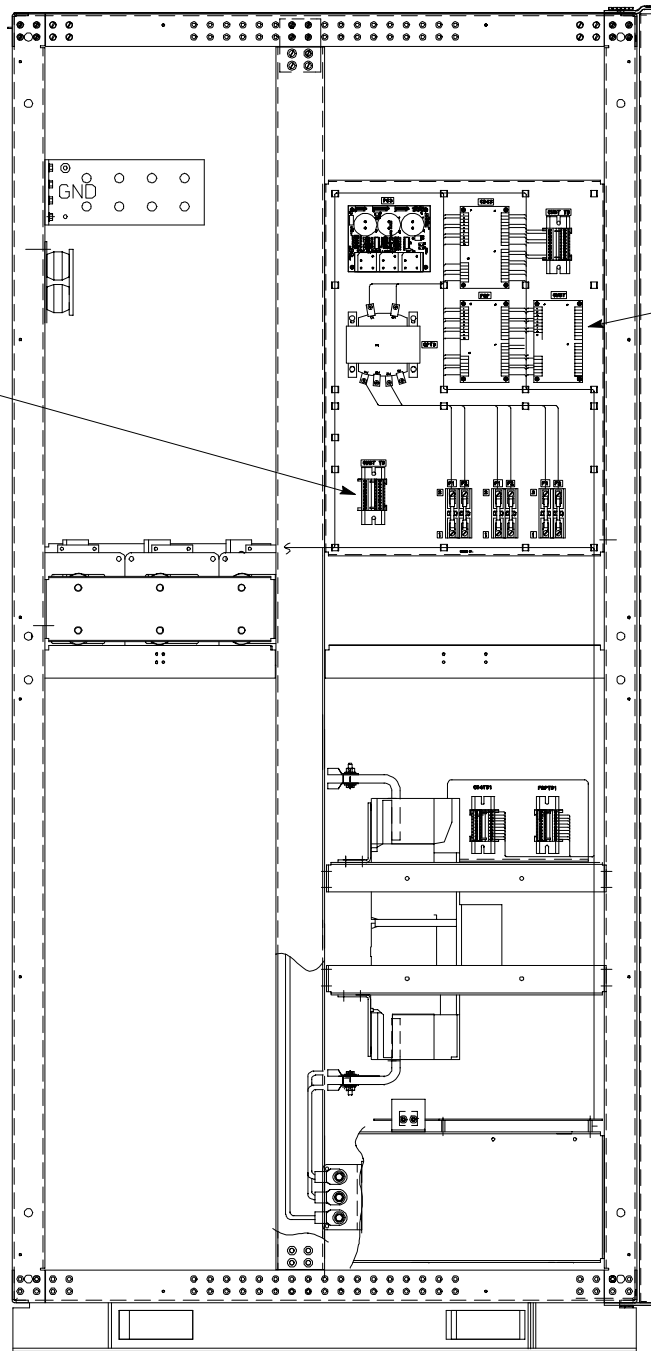

CUST P2, P4

Left Side View, Reverse Transfer Cabinet (MBC)

POWERWARE 9315
MODEL 625-750 (625-750kVA)

<i>DESCRIPTION:</i>		
POWERWARE SYNC CONTROL INTERFACE LOCATION FOR 750kVA UPS		
<i>DRAWING NO:</i>	164201140-2	<i>SHEET:</i> 5 of 5
<i>REVISION:</i>	E	<i>DATE:</i> 021500

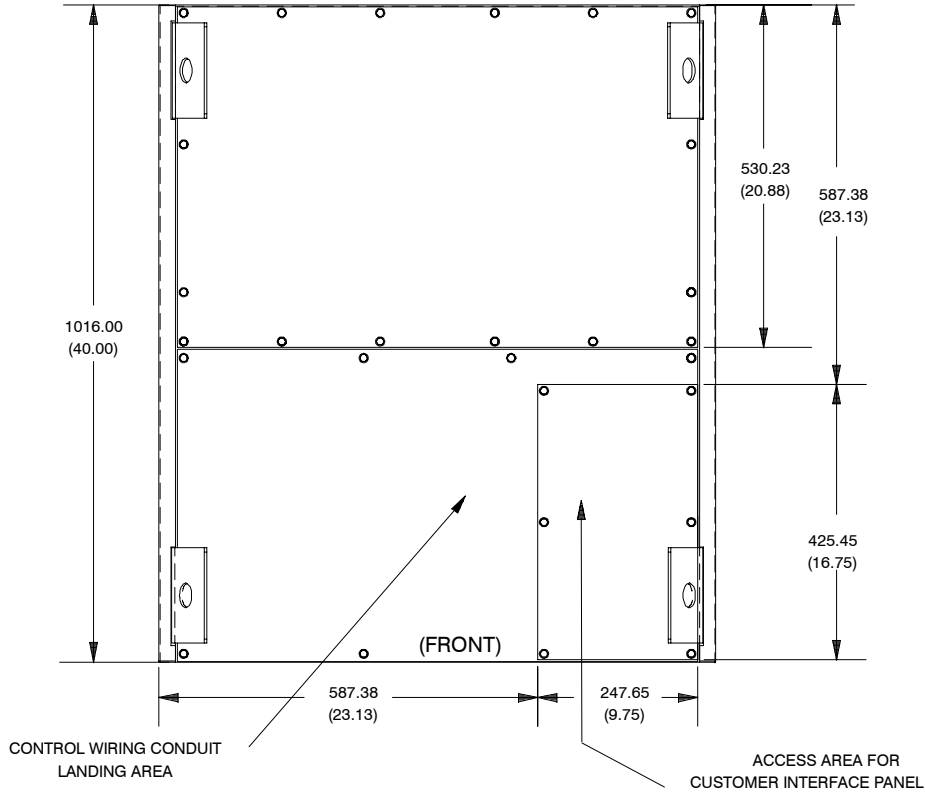

TOP EXTERIOR VIEW

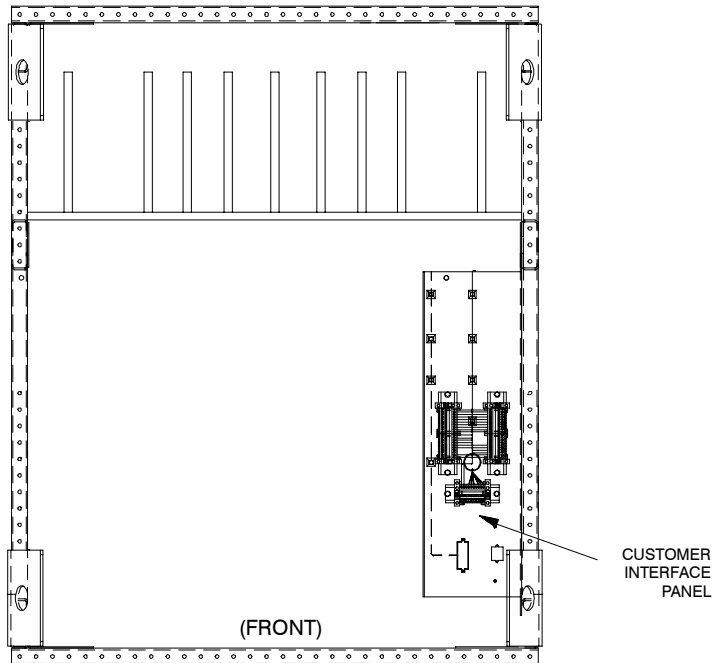

TOP INTERIOR VIEW

DESCRIPTION: POWERWARE SYNC CONTROL INTERFACE LOCATION FOR POWERWARE HOT SYNC – CAPACITY SYSTEM WITH 1200 AMP SBM		
DRAWING NO:	164201140-3	SHEET: 1 of 1
REVISION:	C	DATE: 121598

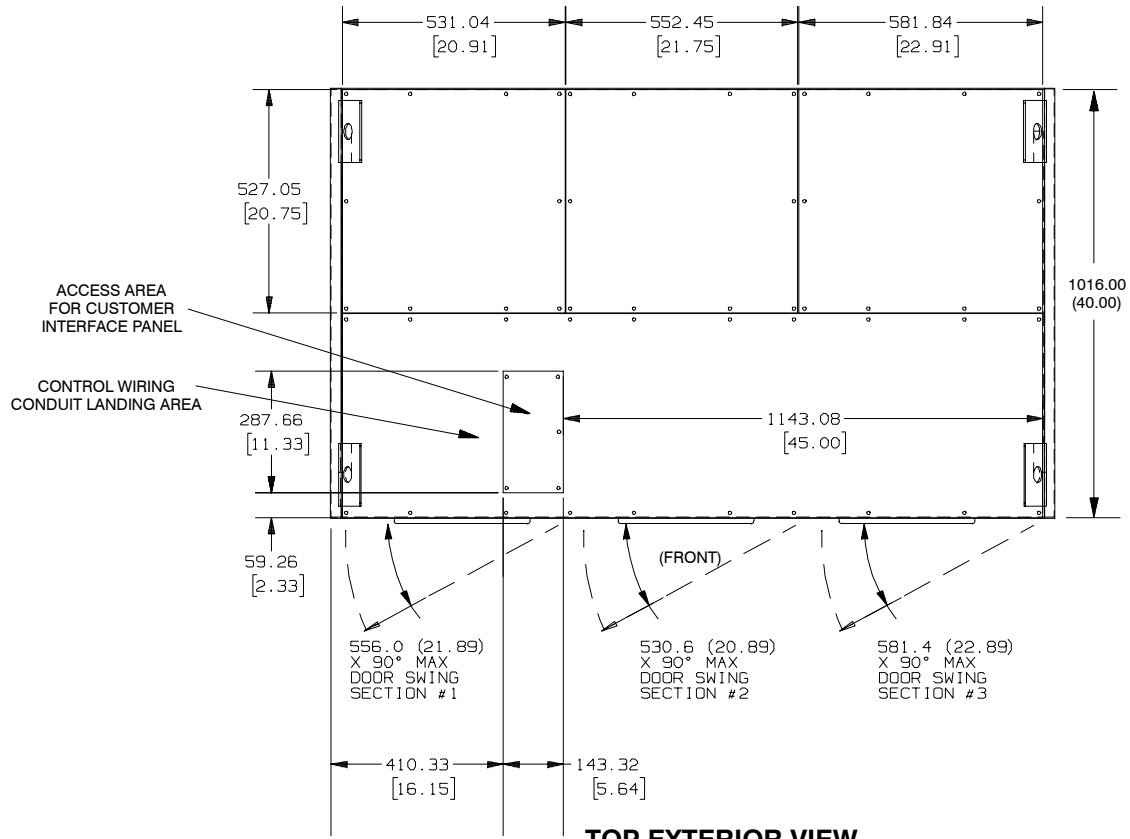

TOP EXTERIOR VIEW

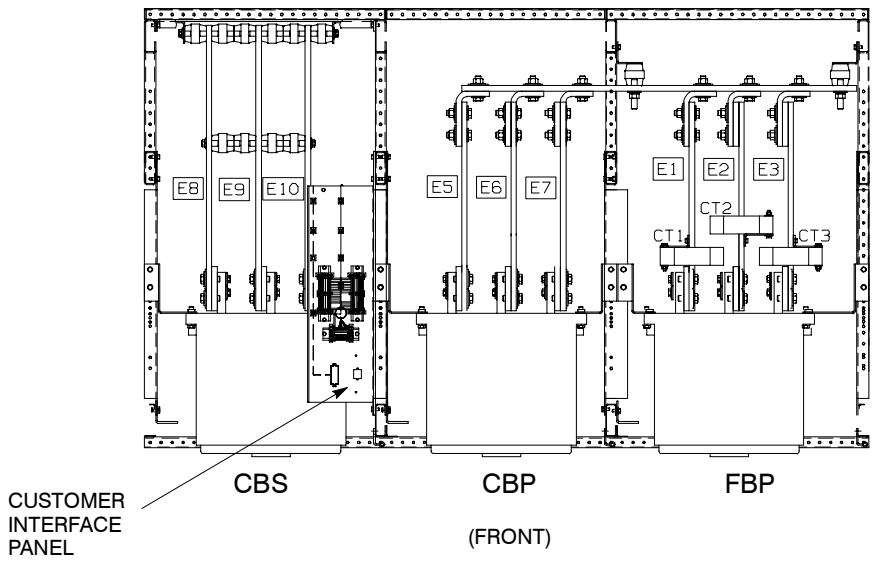

TOP INTERIOR VIEW

DESCRIPTION: POWERWARE SYNC CONTROL INTERFACE LOCATION FOR POWERWARE HOT SYNC – CAPACITY SYSTEM WITH 2000 AMP SBM		
DRAWING NO:	164201140-4	SHEET: 1 of 1
REVISION:	B	DATE: 121598

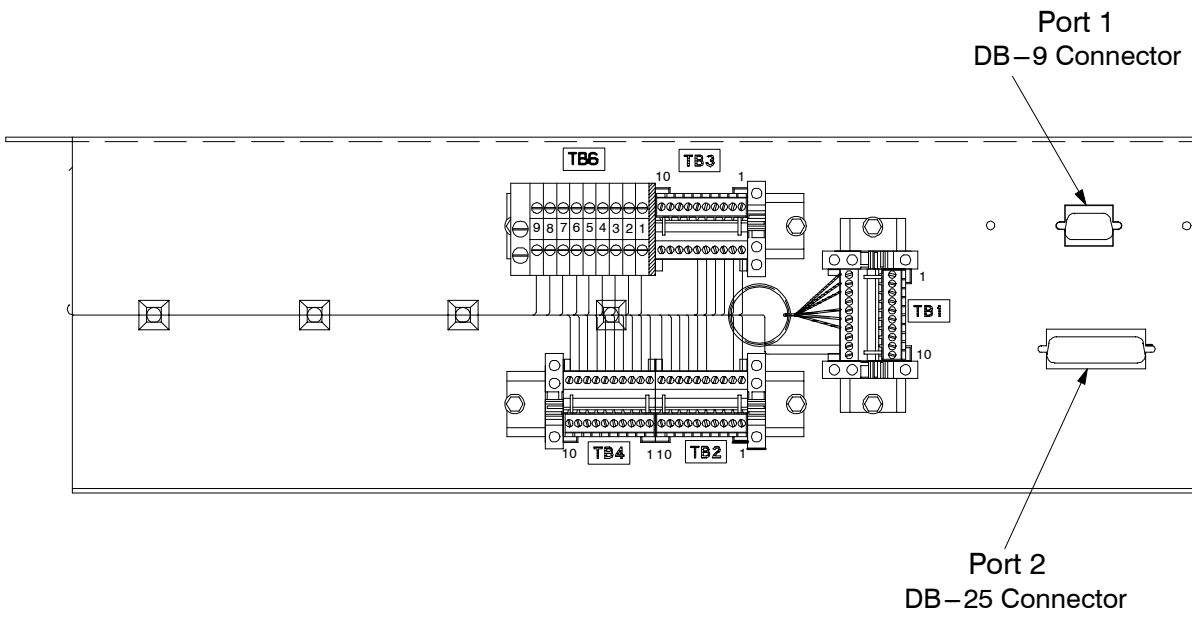

**1200 and 2000 Amp SBM
Customer Interface Panel
Top View**

<i>DESCRIPTION:</i> SBM CUSTOMER INTERFACE PANEL	
<i>DRAWING NO:</i> 164201140-5	<i>SHEET:</i> 1 of 1
<i>REVISION:</i> B	<i>DATE:</i> 031598

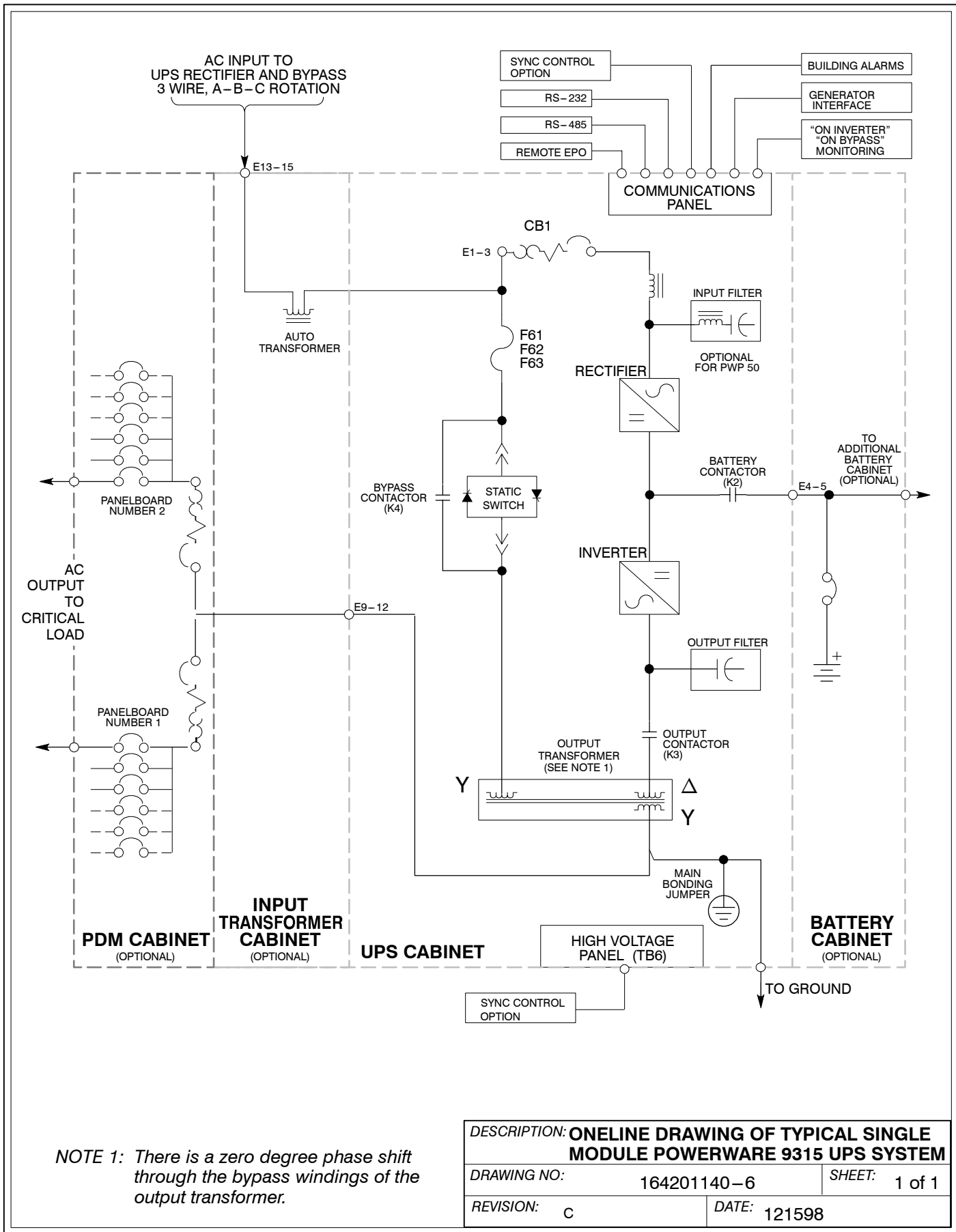

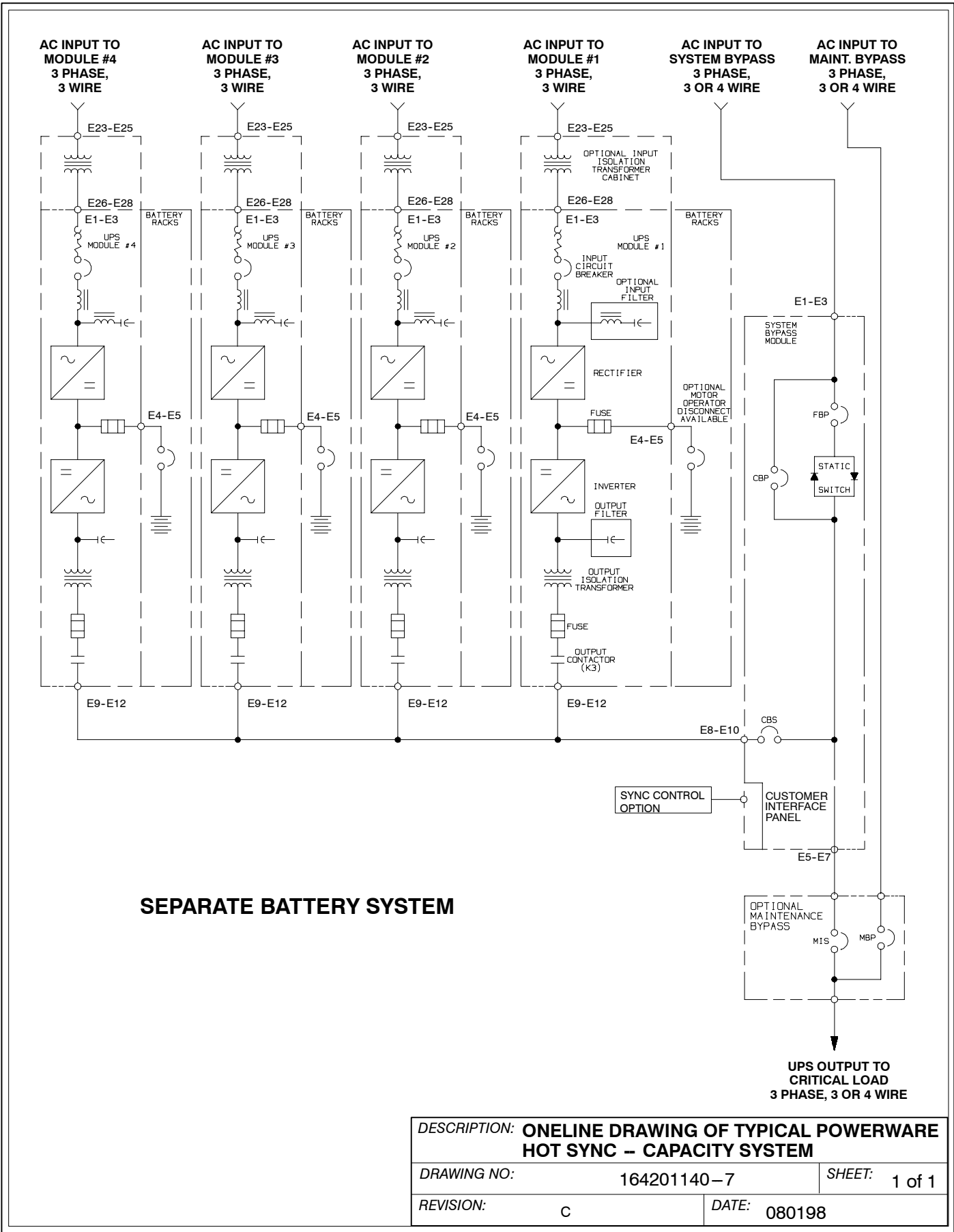

Read and understand the following notes while planning your installation:

1. Refer to national and local electrical codes for acceptable external wiring practices.
2. Material and labor for external wiring requirements are to be provided by others.
3. For external wiring requirements, including the minimum AWG size of external wiring, see the appropriate column in Table 1, 2, or 3.

<i>DESCRIPTION:</i>	INSTALLATION NOTES	
<i>DRAWING NO:</i>	164201140-8	<i>SHEET:</i> 1 of 1
<i>REVISION:</i>	C	<i>DATE:</i> 121598

SINGLE MODULE 30-500 POWERWARE 9315 UPS SYSTEM CONTROL WIRING INTERCONNECTIONS

From UPS - A (refer to drawing 164201140-2)	To Sync Control (refer to drawing 164201140-1)	Wire Size (AWG)	Voltage	Note
TB6-3	TB1-1	14	24VDC	Twist Together
TB6-4	TB1-2	14	24VDC	
TB6-5	TB1-4	14	480VAC	Twist Together
TB6-6	TB1-5	14	480VAC	
TB6-7	TB1-6	14	480VAC	
TB6-11	TB1-13	14	480VAC	Twist Together
TB6-12	TB1-14	14	480VAC	
TB6-13	TB1-15	14	480VAC	
TB6-8	TB1-16	14	480VAC	Twist Together
TB6-9	TB1-17	14	480VAC	
TB6-10	TB1-18	14	480VAC	
TB1-9	TB1-22	14	24VDC	Twist Together
TB1-10	TB1-23	14	24VDC	
TB1-7	TB1-26	14	24VDC	Twist Together
TB1-8	TB1-27	14	24VDC	
From UPS - B	To Sync Control	Wire Size (AWG)	Voltage	Note
TB6-3	TB1-1	14	24VDC	Twist Together
TB6-4	TB1-3	14	24VDC	
TB6-5	TB1-10	14	480VAC	Twist Together
TB6-6	TB1-11	14	480VAC	
TB6-7	TB1-12	14	480VAC	
TB6-11	TB1-7	14	480VAC	Twist Together
TB6-12	TB1-8	14	480VAC	
TB6-13	TB1-9	14	480VAC	
TB6-8	TB1-19	14	480VAC	Twist Together
TB6-9	TB1-20	14	480VAC	
TB6-10	TB1-21	14	480VAC	
TB1-9	TB1-24	14	24VDC	Twist Together
TB1-10	TB1-25	14	24VDC	
TB1-7	TB1-28	14	24VDC	Twist Together
TB1-8	TB1-29	14	24VDC	

Field Wiring Requirements:

- Minimum insulation rating: 600 volts
- Use 14 AWG wiring for interconnections between the Sync Control and the UPS modules
- Install using Class 1 wiring methods.

 CAUTION

Remove the following jumpers, if connected, from UPS module terminal block TB6 when installing the Sync Control:

<u>From</u>	<u>To</u>
TB6-5	TB6-8
TB6-6	TB6-9
TB6-7	TB6-10

DESCRIPTION: TABLE 1 – SINGLE MODULE POWERWARE 9315 UPS SYSTEM CONTROL WIRING INTERCONNECTIONS (30–500kVA only)		
DRAWING NO:	164201140–9	SHEET: 1 of 2
REVISION:	E	DATE: 021500

SINGLE MODULE 750Kva POWERWARE 9315 UPS SYSTEM CONTROL WIRING INTERCONNECTIONS				
From UPS - A (refer to drawing 164201140-2)	To Sync Control (refer to drawing 164201140-1)	Wire Size (AWG)	Voltage	Note
CUSTTB1-1	TB1-1	14	24VDC	Twist Together
CUSTTB1-2	TB1-2	14	24VDC	
CUSTTB2-1	TB1-4	14	480VAC	Twist Together
CUSTTB2-2	TB1-5	14	480VAC	
CUSTTB2-5	TB1-13	14	480VAC	Twist Together
CUSTTB2-6	TB1-14	14	480VAC	
CUSTTB2-3	TB1-16	14	480VAC	Twist Together
CUSTTB2-4	TB1-17	14	480VAC	
CUSTTB-6*	TB1-22	14	24VDC	Twist Together
CUSTTB-7*	TB1-23	14	24VDC	
CUSTP2-4	TB1-26	14	24VDC	Twist Together
CUSTP2-5	TB1-27	14	24VDC	
From UPS - B	To Sync Control	Wire Size (AWG)	Voltage	Note
CUSTTB1-1	TB1-1	14	24VDC	Twist Together
CUSTTB1-2	TB1-3	14	24VDC	
CUSTTB2-1	TB1-10	14	480VAC	Twist Together
CUSTTB2-2	TB1-11	14	480VAC	
CUSTTB2-5	TB1-7	14	480VAC	Twist Together
CUSTTB2-6	TB1-8	14	480VAC	
CUSTTB2-3	TB1-19	14	480VAC	Twist Together
CUSTTB2-4	TB1-20	14	480VAC	
CUSTTB-6*	TB1-24	14	24VDC	Twist Together
CUSTTB-7*	TB1-25	14	24VDC	
CUSTP2-4	TB1-28	14	24VDC	Twist Together
CUSTP2-5	TB1-29	14	24VDC	

*CUST TB located in Inverter Cabinet #2.

CAUTION

Remove the following jumpers, if connected, from UPS module terminal block TB2 when installing the Sync Control:

From	To
TB2-1	TB2-3
TB2-2	TB2-4

Field Wiring Requirements:

- Minimum insulation rating: 600 volts
- Use 14 AWG wiring for interconnections between the Sync Control and the UPS modules
- Install using Class 1 wiring methods.

DESCRIPTION: TABLE 1 – SINGLE MODULE POWERWARE 9315 UPS SYSTEM CONTROL WIRING INTERCONNECTIONS (750kVA only)	
DRAWING NO: 164201140-9	SHEET: 2 of 2
REVISION: E	DATE: 021500

POWERWARE HOT SYNC - CAPACITY CONTROL WIRING INTERCONNECTIONS				
From SBM - A (refer to drawings 164201140-3 and 164201140-4)	To Sync Control (refer to drawing 164201140-1)	Wire Size (AWG)	Voltage	Note
TB4-3	TB1-1	14	24VDC	Twist Together
TB4-4	TB1-2	14	24VDC	
TB6-1	TB1-4	14	480VAC	Twist Together
TB6-2	TB1-5	14	480VAC	
TB6-3	TB1-6	14	480VAC	
TB6-7	TB1-13	14	480VAC	Twist Together
TB6-8	TB1-14	14	480VAC	
TB6-9	TB1-15	14	480VAC	
TB6-4	TB1-16	14	480VAC	Twist Together
TB6-5	TB1-17	14	480VAC	
TB6-6	TB1-18	14	480VAC	
TB3-3	TB1-22	14	24VDC	Twist Together
TB3-4	TB1-23	14	24VDC	
TB3-1	TB1-26	14	24VDC	Twist Together
TB3-2	TB1-27	14	24VDC	
From SBM - B	To Sync Control	Wire Size (AWG)	Voltage	Note
TB4-3	TB1-1	14	24VDC	Twist Together
TB4-4	TB1-3	14	24VDC	
TB6-1	TB1-10	14	480VAC	Twist Together
TB6-2	TB1-11	14	480VAC	
TB6-3	TB1-12	14	480VAC	
TB6-7	TB1-7	14	480VAC	Twist Together
TB6-8	TB1-8	14	480VAC	
TB6-9	TB1-9	14	480VAC	
TB6-4	TB1-19	14	480VAC	Twist Together
TB6-5	TB1-20	14	480VAC	
TB6-6	TB1-21	14	480VAC	
TB3-3	TB1-24	14	24VDC	Twist Together
TB3-4	TB1-25	14	24VDC	
TB3-1	TB1-28	14	24VDC	Twist Together
TB3-2	TB1-29	14	24VDC	

CAUTION

Remove the following jumpers, if connected, from SBM terminal block TB6 when installing the Sync Control:

<u>From</u>	<u>To</u>
TB6-1	TB6-4
TB6-2	TB6-5
TB6-3	TB6-6

Field Wiring Requirements:

- Minimum insulation rating: 600 volts
- Use 14 AWG wiring for interconnections between the Sync Control and the SBM
- Install using Class 1 wiring methods.

DESCRIPTION:	TABLE 2 -- POWERWARE HOT SYNC -- CAPACITY SYSTEM CONTROL WIRING INTERCONNECTIONS	
DRAWING NO:	164201140-10	SHEET: 1 of 1
REVISION:	C	DATE: 121598

CUSTOMER REMOTE MONITORING SYSTEM WIRING INTERCONNECTIONS			
Function	From Sync Control	Wire Size (AWG)	Note
UPS System A Active Master Source	TB1-31	14	Twist Together
Common Return	TB1-30	14	
UPS System B Active Master Source	TB1-32	14	Twist Together
Common Return	TB1-30	14	
UPS System A Synchronized to Load B	TB1-33	14	Twist Together
Common Return	TB1-30	14	
UPS System B Synchronized to Load A	TB1-34	14	Twist Together
Common Return	TB1-30	14	
Load Sync Enabled	TB1-36	14	Twist Together
Common Return	TB1-35	14	

Note: Sync Control dry contacts are rated at 5–30 VDC/250 VAC at 2A per contact (maximum load).

Field Wiring Requirements:

- Minimum insulation rating: 600 volts
- Use 14 AWG wiring for interconnections between the Sync Control and the customer Remote monitoring system.
- Install using Class 1 wiring methods.

<i>DESCRIPTION:</i> TABLE 3 – CUSTOMER REMOTE MONITORING SYSTEM WIRING INTERCONNECTIONS	
<i>DRAWING NO:</i> 164201140-11	<i>SHEET:</i> 1 of 1
<i>REVISION:</i> C	<i>DATE:</i> 121598

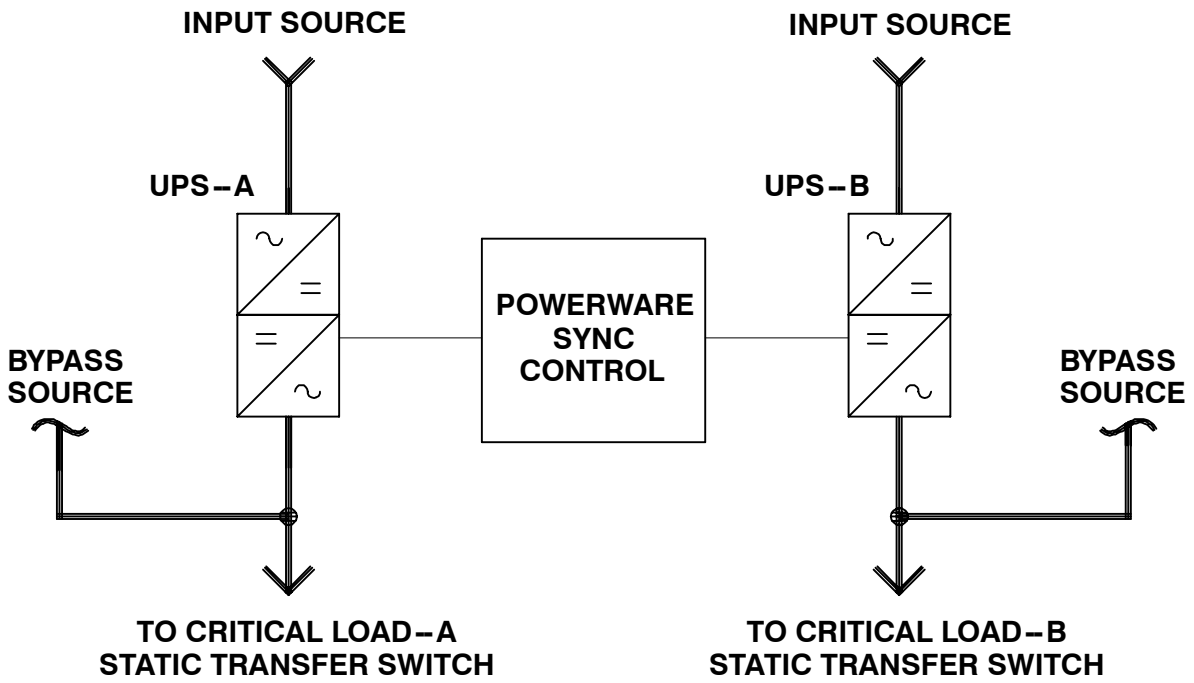

<i>DESCRIPTION:</i> SIMPLIFIED SINGLE MODULE POWERWARE 9315 UPS SYSTEM ONLINE		
<i>DRAWING NO:</i>	164201140-12	<i>SHEET:</i> 1 of 1
<i>REVISION:</i>	C	<i>DATE:</i> 121598

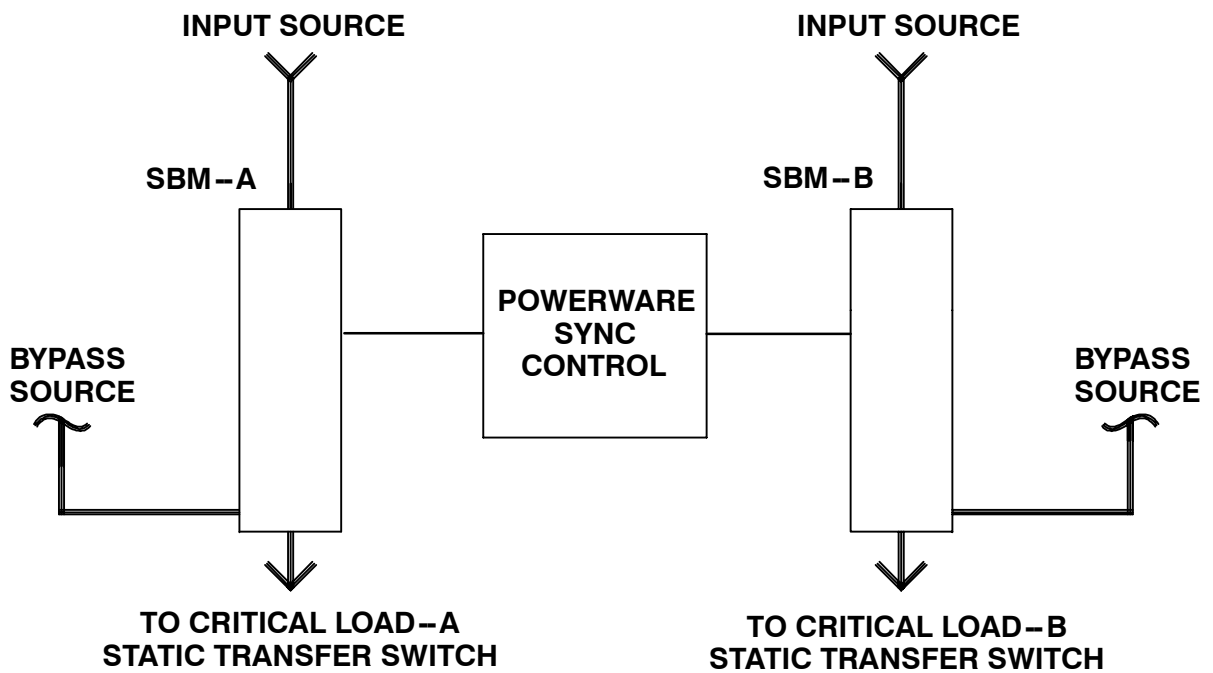

<i>DESCRIPTION:</i> SIMPLIFIED POWERWARE HOT SYNC – CAPACITY SYSTEM ONLINE		
<i>DRAWING NO:</i>	164201140–13	<i>SHEET:</i> 1 of 1
<i>REVISION:</i>	C	<i>DATE:</i> 121598

This Page Intentionally Left Blank.