

Liebert® NX™ 1+1 System

Product Specification/Installation Sheet



General

The Liebert NX UPS uses intelligent and reliable decentralized technology to achieve parallel operation of two modules of the same rating.

The 1+1 system is used to:

- Increase the reliability of the system to ensure adequate power supply to the critical load.
- Increase serviceability and allow the execution of maintenance operations and reparations without affecting the ordinary operating conditions of the system (depending on the redundancy level).



CAUTION

An external maintenance cabinet is strongly recommended to maintain the power supply to load in case of complete maintenance.

Conditions for Parallel System

1. Each UPS module should have the same rating, the same firmware and hardware version.
2. Each UPS module must have the same bypass source.
3. The outputs of all UPS modules are connected altogether.
4. The main inputs can be from different sources, but the phase rotation sequence of main inputs, bypass inputs and outputs must be correct and the same.

5. The parallel logic cable and load sharing cable must be connected in a ring correctly (see **Figure 2**).

Features of Parallel System

1. The hardware and firmware for parallel UPS module operation is standard in the Liebert NX, and the configuration can be set up by changing the settings in configuration software.
2. It is easy to install the parallel cables in a ring, providing high reliability and redundancy. And the intelligent paralleling logic provides the user with maximum flexibility. For example, shutting down or starting up the UPS modules in the parallel system can be done in any sequence. If an overload transfer occurs, the whole system can recover automatically from bypass mode after the overload is cleared.
3. The total load of the parallel system can be queried from each module's LCD screen.
4. Optional monitoring background software can treat the entire parallel system as a big single-module UPS, and provide corresponding management. It can also get the information for all modules by connecting to just one of the modules.

Figure 1 '1+1' System block diagram

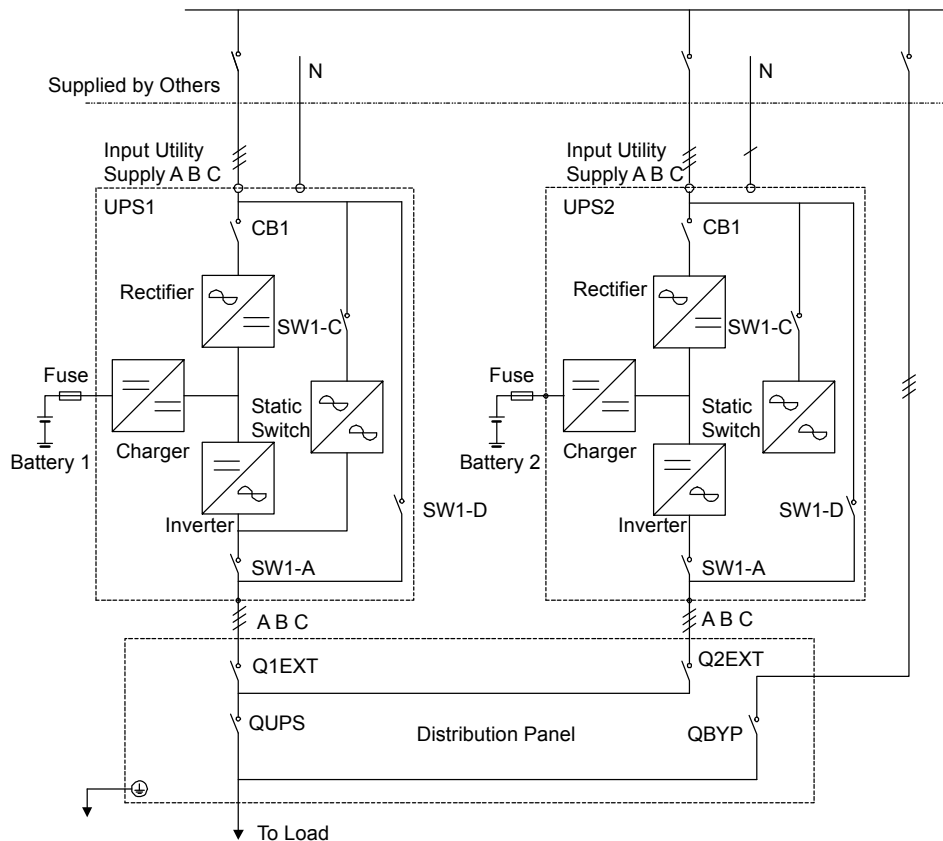

Operating Principles

Redundancy Paralleling

The redundancy parallel system can noticeably improve system reliability. In normal condition, neither UPS module works at full load. That means that even if the load is increased, the system will not transfer to bypass. When a UPS module shuts down due to any failure, the remaining UPS module can still power and protect the load. When redundancy is lost due to module failure or load increase, the parallel system will trigger an alarm.

Operation Modes Summary

The parallel system has operation modes such as Normal, Battery, Bypass and Maintenance Bypass.

All UPS modules in the 1+1 parallel system operate in coordination.

- **Normal Mode Operation**

The load is powered by the inverters of all the UPS modules in the system. If the frequency of bypass is within the synchronous range, the inverter will be synchronized with the bypass. Otherwise, the system will operate at nominal frequency.

- **Battery Mode Operation**

The batteries of all UPS modules power the load through their inverters. The system operates at nominal frequency.

- **Bypass Mode Operation**

The condition to transfer to bypass mode is the same as that for a single module system. The bypass of all the UPS modules powers the load.

- **Maintenance Bypass Mode Operation**

The sequence to transfer to maintenance bypass mode is the same as for transferring a single module system. The maintenance bypass switches should be switched On as synchronously as possible. Thus the system can be repaired without interrupting the power supply to critical load.

Intermodule Control

Two kinds of signals are used for the parallel cables:

- **Analog signals**—UPS output unbalanced current
- **Digital signals**—control logic signals, parallel cable status parallel control cables should be connected to the parallel board (M3) of all modules and form a ring to provide redundancy as shown in **Figure 2**.

Two types of parallel control cables are needed:

- **DB9** for analog signals with one end DB9/F and one end DB9/M.
- **DB25** for digital signals with one end DB25/F and one end DB25/M. These come in lengths of 15 ft., 25 ft. and 50 ft. (4.5, 7.6 and 15.2m).

Installation

The basic installation procedure of parallel system is the same as that for single module system. The following sections only introduce the installation procedures specific to the parallel system.

Cabinet Installation

Parallel system composed of two UPS modules

The two UPS modules that will form the 1+1 system should be placed side-by-side. Each battery cabinet is placed next to its corresponding UPS module.

Preliminary Checks

Each UPS module should have the same rating, the same firmware and the same hardware version.

Refer to the instructions in **Conditions for Parallel System on page 1**.

Protective Devices

Refer to the instructions in the Liebert NX installation manual, SL-25215.

Power Cables

Wiring of power cables is similar to that of single module system (see the Liebert NX installation manual, SL-25215). The bypass sources of all modules should be the same, and the outputs should be connected altogether correctly.

Parallel Control Cables



NOTE

The length and specifications of power cables including the bypass input cables and UPS output cables should be the same so the load can be shared evenly in bypass mode.

Make the connections below on the parallel logic board (M3) inside the Liebert NX:

- Connect one end of the DB-25 interconnecting cable to the X2_1 connector of UPS 1 and the other end to the X2_2 connector of UPS 2.
- Connect one end of the DB-25 interconnecting cable the X2_2 connector of UPS 1 and the other end to the X2_1 connector of UPS 2.
- Connect one end of the DB-9 interconnecting cable the X1_1 connector of UPS 1 and the other end to the X1_2 connector of UPS 2.
- Connect one end of the DB-9 interconnecting cable the X1_2 connector of UPS 1 and the other end to the X1_1 connector of UPS 2.

The connections are shown in **Figure 2**.

Figure 2 Connecting 1+1 system parallel control cables

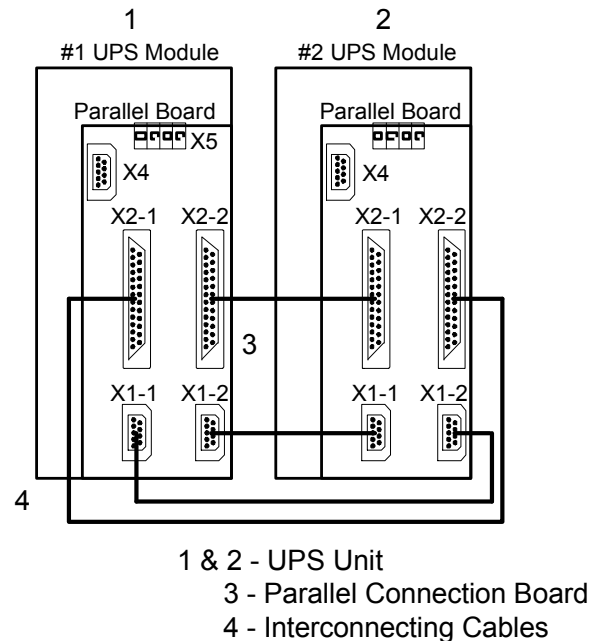

Commissioning a Parallel System



CAUTION

The operations in this section must be performed by authorized electricians or qualified technical personnel. If you have any difficulties, contact Emerson Network Power Liebert Services at 800-543-2378.

Check the input and output wiring of each UPS module. Ensure that the phase rotation sequence of the main inputs and the bypass inputs and outputs of each UPS module are the same. Ensure that the parallel cables are connected firmly.

It is assumed that the installation is complete, the system has been commissioned by authorized personnel and the external power isolators are closed. **Disconnect the load before startup.**

Start the UPS modules separately and set the parameters of each UPS module through configuration software. Pay particular attention to the parameters relevant to the parallel system:

- **UPS Configuration:** Each UPS module belonging to the parallel system should be set as Parallel configuration.
- **UPS ID No.:** Each UPS module should have a unique identification number in the parallel system.
- **Parallel system requisite UPS units:** Set the minimum number of UPS modules to support the expected load. For 1+1 systems this must be set to 1.

- **Parallel system redundant UPS units:** Set the number of redundant UPS modules. This will prevent the system from transferring to Bypass if a fault condition occurs on the Master UPS in the parallel system. For 1+1 systems, this must be set to 1.



NOTE

The settings should be the same for all modules within the parallel system, except the UPS ID No.

System Startup

1. Start each UPS normally as described in Liebert NX installation manual, SL-25215.
2. Turn On the inverter of each UPS module one at a time.
3. Apply the load after the last UPS module transfers to inverter. The total load can be determined through the LCD of either UPS.
4. Verify the load rate of each UPS module. If the load rates are roughly the same, then the parallel system may be assumed to be operating normally.

Emergency Power Off (EPO)

The external emergency stop facility is identical to that described for the single unit installation—that an individual emergency stop button is provided for each unit. Note that this is a Normally Open switch.



NOTE

If one module will not transfer to Inverter Mode long after its inverter is On, its output connection may not be good or its output phase rotation may not be coincident with that of other modules. At this time, the LCD for the UPS module will display “inverter asynchronous” and the inverter indicator will flash continuously. If either UPS module makes abnormal noise after it transfers to inverter, its parallel cables may be incorrectly connected.

Figure 3 Connecting EPO push button

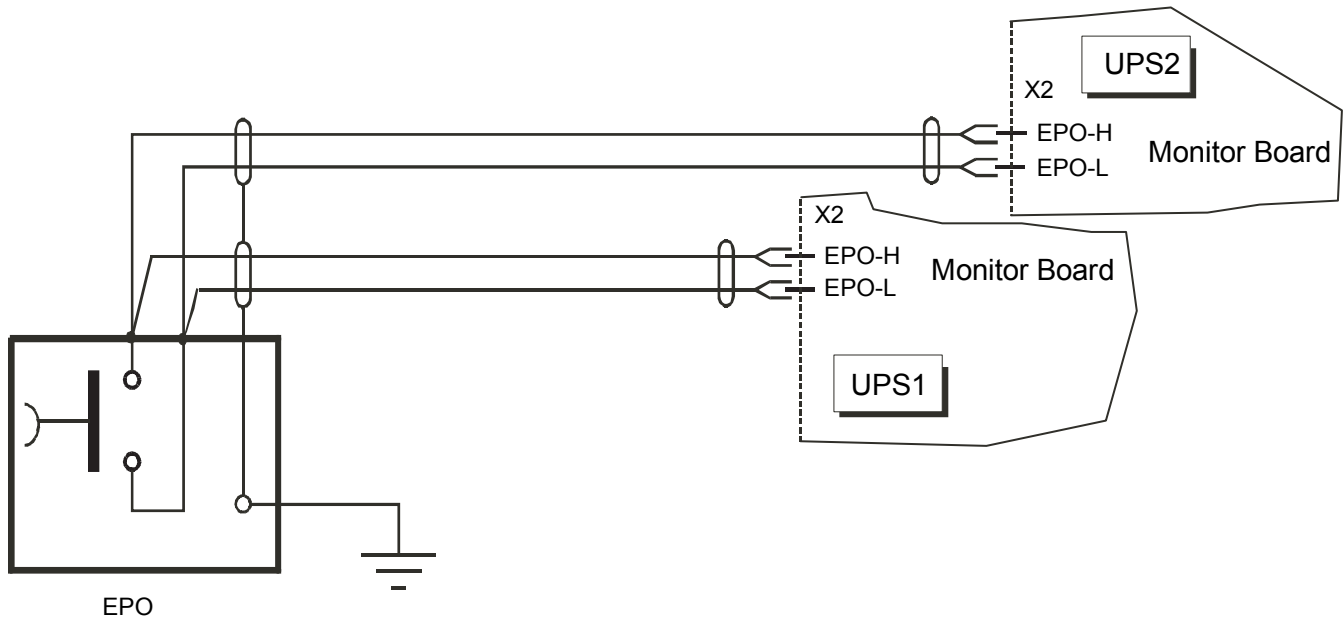

Liebert Corporation

1050 Dearborn Drive
P.O. Box 29186
Columbus, OH 43229

Telephone: 1-800-877-9222
Facsimile: 1-614-841-6022
www.liebert.com



© 2004 Liebert Corporation
All rights reserved throughout the world. Specifications subject to change without notice.

® Liebert is a registered trademark of Liebert Corporation. All names referred to are trademarks or registered trademarks of their respective owners.

SL-25246_REV1_04-11