

LIEBERT® NXL™ 500-750kVA, SINGLE-MODULE SYSTEMS SITE PLANNING DATA

Table 1 Site planning data—500-750kVA

UPS Rating		AC Input/Output Voltage	Rectifier AC Input Current		Bypass/Output AC Output Current		Required Battery Disconnect Rating (A)	Max. Battery Current at End of Discharge (A)	Max. Heat Dissipation Full Load, BTU/h (kW)	Dimensions	Approx. Weight Unpacked	Floor Loading Average
kVA	kW	VAC	Nom	Max	Nom	Max				WxDxH: in. (mm)	lb. (kg)	lb./ft. ² (kg/m ²)
500	450	480	643	804	601	752	1400	1241	124,805 (36.6)	111.6x39.4x76.8 (2835x1000x1950)	10,310 (4677)	337.6 (1650)
625	562.5	480	799	995	752	940	1600	1530	167,265 (49.0)	140.5x39.4x76.8 (3568x1000x1950)	13,650 (6192)	355 (1735)
750	675	480	975	1219	902	1128	2000	1845	213,587 (62.6)			
750	675	575	815	1018	753	941	2000	1851	215,790 (63.2)			
750	675	600	759	949	722	902	2000	1845	200,173 (58.7)			
See Notes below:			1,3,6,7,8,10,11		2,3,4,6,7,8,10,11		5,6,8,10,11		—	9	9	9

Notes for Table 1

- Nominal rectifier AC input current (considered continuous) is based on full rated output load. Maximum current includes nominal input current and maximum battery recharge current (considered non-continuous). Maximum input current is controlled by current limit setting, which is adjustable 25 to 125% of nominal input current.
- Bypass AC input and AC output current (considered continuous) is based on full rated output load. Maximum current includes nominal output current and overload current for 10 minutes.
- Feeder protection (by others) for rectifier AC input and bypass AC input is recommended to be provided by separate overcurrent protection devices.
- UPS output load cables must be run in separate conduit from input cables.
- Power cable from module DC bus to battery should be sized for a total maximum 2.0 volt line drop (power cable drop plus return cable drop as measured at the module) at maximum discharge current.
- Grounding conductors to be sized per NEC 250-95. Neutral conductors to be sized for full capacity-per NEC 310-16, Note 10-for systems with 4-wire loads and 20% minimum capacity for 3-wire loads.
- Rectifier AC Input: 3-phase, 3-wire, plus ground
Bypass AC Input: 3-phase, 4-wire, plus ground (3-wire plus ground in certain circumstances)
AC Output to Load: 3-phase, 3- or 4-wire, plus ground
Module DC Input from Battery: 2-wire (positive and negative), plus ground
- All wiring is to be in accordance with National and Local Electrical Codes.
- Minimum overhead clearance is 2 ft. (0.6m) above the UPS.
- Top or bottom cable entry through removable access plates. Cut plate to suit conduit size.
- Control wiring and power cables must be run in separate conduits. Control wiring must be stranded tinned conductors.



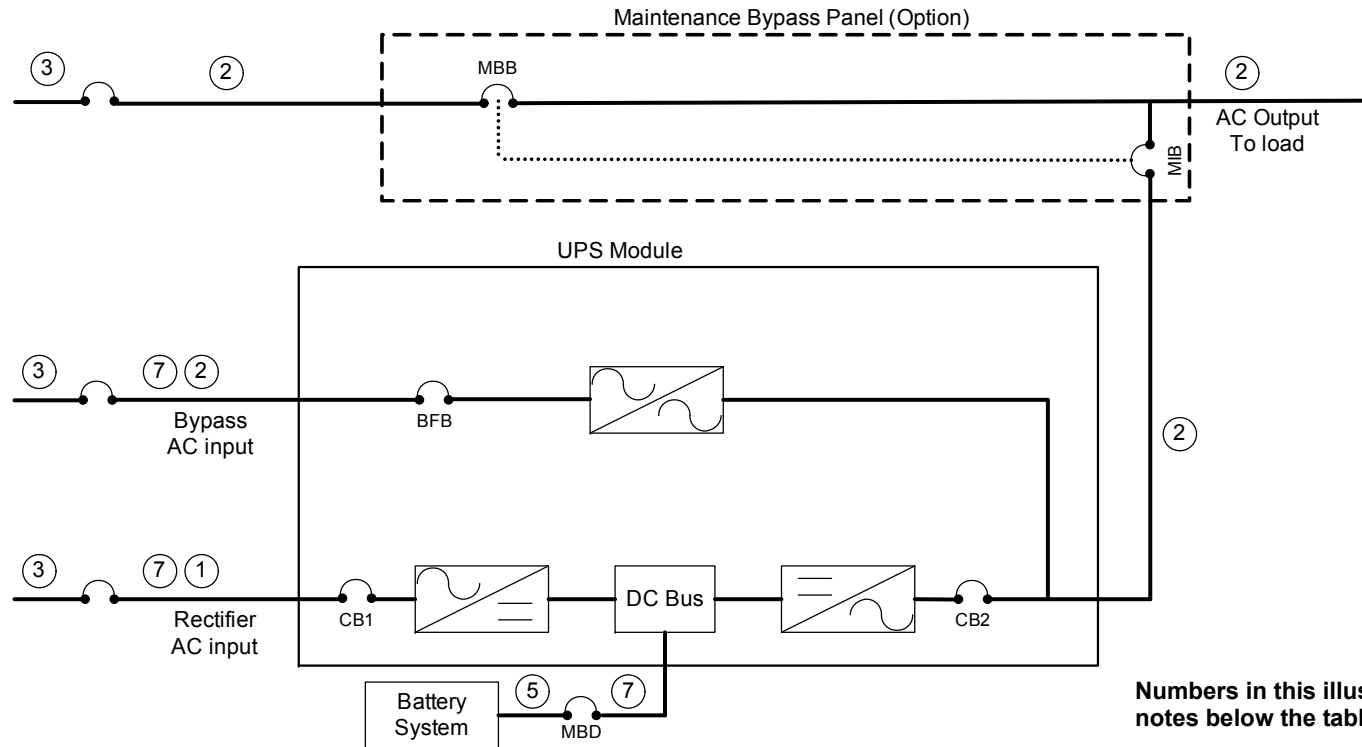

© 2009 Liebert Corporation
 All rights reserved throughout the world. Specifications subject to change without notice.
 ® Liebert is a registered trademark of Liebert Corporation.
 All names referred to are trademarks or registered trademarks of their respective owners.
 SL-25517_REV3_07-11 DRAFT

Technical Support / Service
 800-543-2378
 powertech@emersonnetworkpower.com
Web site: www.liebert.com

United States
 1050 Dearborn Drive
 P.O. Box 29186
 Columbus, OH 43229