

■ A technical manual from the experts
in *Business-Critical Continuity™*

NetSure™ ITM

Installation Manual — 48V DC UPS

Section 6040 (Issue 08, December 10, 2010)

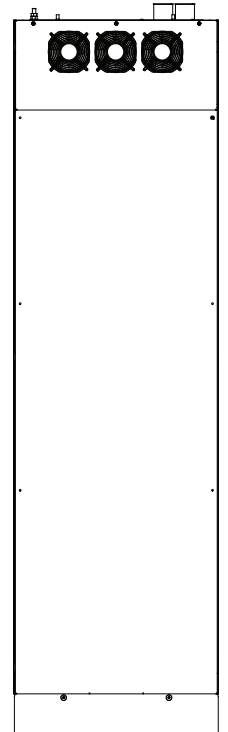
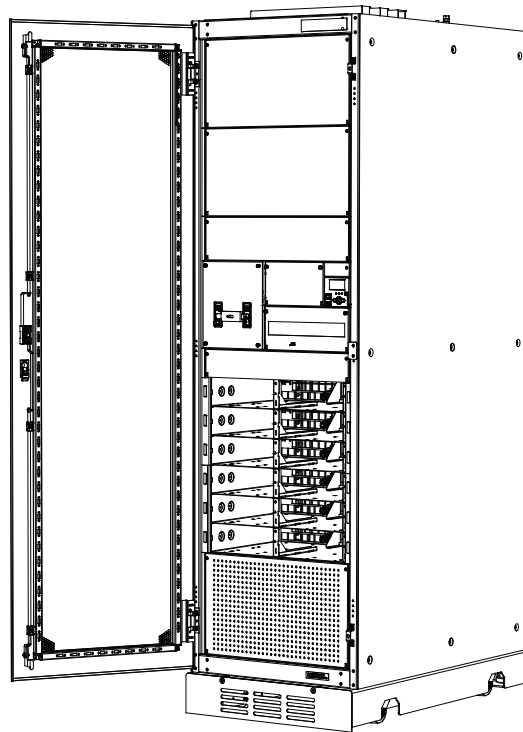
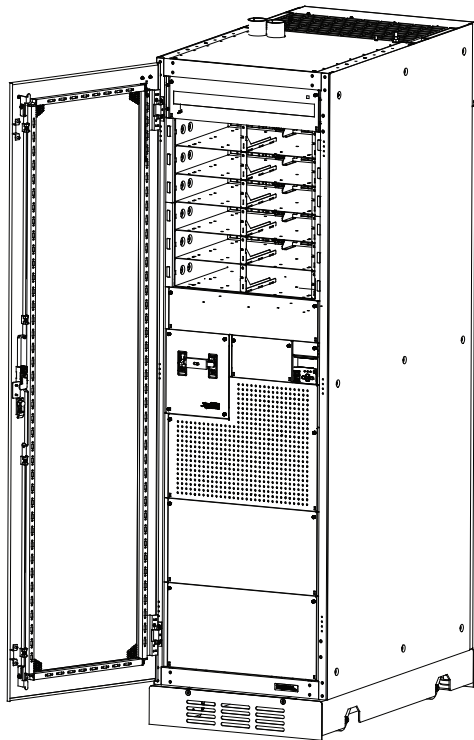

Business-Critical Continuity™, Emerson Network Power, and the Emerson Network Power logo are trademarks and service marks of Emerson Electric Co.

NetSure™, NetSpan™, NetReach™, NetXtend™, and NetPerform™ are trademarks of Emerson Network Power, Energy Systems, North America, Inc.

All other trademarks are the property of their respective owners.

The products covered by this instruction manual are manufactured and/or sold by Emerson Network Power, Energy Systems, North America, Inc.

The information contained in this document is subject to change without notice and may not be suitable for all applications. While every precaution has been taken to ensure the accuracy and completeness of this document, Emerson Network Power, Energy Systems, North America, Inc. assumes no responsibility and disclaims all liability for damages resulting from use of this information or for any errors or omissions. Refer to other local practices or building codes as applicable for the correct methods, tools, and materials to be used in performing procedures not specifically described in this document.

This document is the property of Emerson Network Power, Energy Systems, North America, Inc. and contains confidential and proprietary information owned by Emerson Network Power, Energy Systems, North America, Inc. Any copying, use or disclosure of it without the written permission of Emerson Network Power, Energy Systems, North America, Inc. is strictly prohibited.

TABLE OF CONTENTS

IMPORTANT SAFETY INSTRUCTIONS	1
1.0 INSPECTING THE EQUIPMENT AND STORING FOR DELAYED INSTALLATIONS	4
1.1 External Inspections	4
1.2 Internal Inspections	4
1.3 Storing for Delayed Installation	4
2.0 INSTALLATION DRAWINGS AND RECOMMENDED TOOLS AND TEST EQUIPMENT	6
2.1 Installation Drawings	6
2.2 Row-Based Installation Example	11
2.3 Recommended Tools and Test Equipment	12
3.0 POSITIONING THE DC UPS SYSTEM	13
3.1 General Requirements	13
3.2 General Guidelines for Positioning the DC UPS Modules	13
3.2.1 Cable Entry	13
3.2.2 Environmental Considerations	13
3.2.3 Mechanical Considerations	14
3.3 Floor Installation	14
3.4 Considerations in Moving the DC UPS Module	15
3.4.1 Transporting	15
3.4.2 Moving a DC UPS Module	15
3.4.3 Final Positioning	15
3.5 Overhead Cable Tray Rails	16
3.6 For Top DC Distribution Feed (Top Cabled) Modules Only: Installing the Supplied Air Duct Assembly	17
4.0 ELECTRICAL CONNECTIONS	18
4.1 Wiring Information and Guidelines	18
4.1.1 Cable Lengths (Floor or Cabinet Top to Connection Point Inside DC UPS Module)	18
4.1.2 Recommended Wire Sizes, Recommended Lugs, and Torque Requirements	18
4.1.3 Wiring Guidelines	18
4.2 Protective Covers	19
4.3 Wiring Connections Locations	20
4.4 Making Electrical Connections	22
4.4.1 Cabinet Grounding Connection	22
4.4.2 DC Output Distribution Connections	22
4.4.3 AC Input Power Connections	24
4.4.4 Optional Alarm/Control Connections (to Primary Module only)	26
4.4.5 ACU + Controller Ethernet Connection (to Primary Module only)	29
4.4.6 Optional Emergency Power Off (EPO) Connection (to Primary Module only)	30
4.4.7 Battery Connections	31
4.5 Making Module-to-Module -48VDC and Ground/Return Interconnections (if system consists of multiple DC UPS modules)	31
4.5.1 -48Vdc and Ground/Return Busbar Interconnects	31

4.6	Making Alarm/Control Interconnections between Modules (if system consists of multiple DC UPS modules).....	34
4.6.1	RS-485 Module-to-Module Interconnect	34
4.6.2	CAN-Bus Module-to-Module Interconnect	34
4.6.3	BLVD Module-to-Module Interconnect	35
5.0	INSTALLING PCUS	41
6.0	START-UP INSTRUCTIONS	42
6.1	General	42
6.2	Final Battery Connections	42
6.2.1	Introduction	42
6.2.2	Safety	42
6.2.3	Connecting Batteries	42
6.3	Initially Starting and Verifying DC UPS System Operation.....	45
6.3.1	Initially Starting the DC UPS System and Verifying System Operation.....	45
7.0	SPECIFICATIONS AND TECHNICAL DATA	46
7.1	Agency Approvals	46
7.2	Environmental	46
7.3	Mechanical Characteristics	46
7.4	Monitoring Capability	47
7.5	Electrical Characteristics.....	48
7.5.1	Termination Type, Recommended Wire Size, Recommended Lugs.....	48
7.5.2	Power Ratings.....	50
7.5.3	AC Input Specifications	50
7.5.4	DC Output Specifications.....	50
7.5.5	Battery Specifications	51
8.0	REVISION RECORD	52

FIGURES

Figure 1	Outline Drawing	7
Figure 2	Bottom DC Distribution Feed Modules	9
Figure 3	Top DC Distribution Feed Modules	10
Figure 4	NetSure™ ITM Row-Based DC UPS System Installation Example	11
Figure 5	Emerson Floor Stands	14
Figure 6	Mounting Locations for Overhead Cable Tray Rails.	16
Figure 7	Installing Air Duct Assembly	17
Figure 8	Protective Covers	19
Figure 9	Wiring Connections Locations (DC UPS Module with Bottom Feed DC Distribution)	20
Figure 10	Wiring Connections Locations (DC UPS Module with Top Feed DC Distribution)	21
Figure 11	Cabinet Grounding Connection	22
Figure 12	DC Output Connections	23
Figure 13	AC Input Power Connection Routing Options.	25
Figure 14	Installing Conduit Fittings when AC is Fed from the Top.	25
Figure 15	AC Input Power Connections	25
Figure 16	Alarm and Control Connections	26
Figure 17	ACU+ Controller RJ-45 Ethernet Port	29
Figure 18	EPO Jumper Location.	30
Figure 19	Module-Module Interconnect Busbars (DC UPS Module with Bottom Feed DC Distribution)	32
Figure 20	Module-Module Interconnect Busbars (DC UPS Module with Top Feed DC Distribution)	33
Figure 21	SM-BRC RS-485 Jumper Locations	34
Figure 22	Alarm/Control Cable Interconnects (cont'd on next page)	36
Figure 23	System Configuration and Communications Connections	38
Figure 24	Cabinet Interconnections	39
Figure 25	Signal Cabling and Switch Settings.	40
Figure 26	PCU Handle and Safety Latch	41
Figure 27	Making Final Battery Shelf Battery Interconnect Link Connections	43
Figure 28	Field Battery Monitoring Lead Connections to the SiteWeb™ BRC Unit.	44

TABLES

Table 1	DC UPS Module "Base Configuration Part Numbers" and "Configured System Spec. Numbers"	5
Table 2	Distance to Connection Points inside the DC UPS Module	18
Table 3	Programmable Digital Inputs	27
Table 4	Programmable Relay Outputs	28
Table 5	IB2 Board Communications Address Settings	29
Table 6	ACU+ Controller RJ-45 Ethernet Port	29
Table 7	DC UPS System Environmental Characteristics	46
Table 8	DC UPS System Mechanical Characteristics (per module)	46
Table 9	Shipping Dimensions and Weights	47
Table 10	AC Input and AC Input Grounding (per DC UPS module)	48
Table 11	Cabinet Frame Grounding (per DC UPS module).	48
Table 12	DC Distribution (Distribution Circuit Breaker Option - per circuit breaker position).	49
Table 13	DC Distribution (Distribution Fuse Option - per fuse position).	49
Table 14	Alarm/Control	49
Table 15	Power Ratings	50
Table 16	AC Input Specifications	50
Table 17	DC Output Specifications	50
Table 18	Battery Specifications.	51

IMPORTANT SAFETY INSTRUCTIONS

SAVE THESE INSTRUCTIONS

This manual contains important instructions that should be followed during installation of your Net-Sure™ ITM Row-Based DC UPS system.

Read this manual thoroughly before installing the DC UPS system. **Retain this manual for use by installing personnel.**



WARNING

The DC UPS system should be installed by a qualified technician in accordance with the information contained in this document.



WARNING

Special safety precautions are required for procedures involving handling and installation of the DC UPS system. Observe all safety precautions in this manual before handling or installing the DC UPS system.



WARNING

Exercise extreme care when handling DC UPS modules (cabinets) to avoid equipment damage or injury to personnel. The DC UPS module weighs 3240 lb. (1470 kg), fully loaded.

Be aware of module weight and locate center of gravity symbols  before handling the DC UPS module. Test lift and balance the module before transporting. Never tilt module more than 10 degrees from vertical.



WARNING

All power and control wiring should be installed by a qualified electrician. All power and control wiring must comply with the National Electrical Code (NEC) and applicable local codes.

Maximum load must not exceed that shown on the DC UPS module rating label.

Maximum output short circuit current is 7000 amperes.



WARNING

High Ground Leakage Current:

Ground connection is essential before connecting the input supply.

This equipment must be grounded in accordance with the NEC and applicable local codes.



CAUTION

Ground leakage current exceeds 3.5 mA and is less than 30 mA.

Transient and steady-state ground leakage currents, which may occur when starting the equipment, should be taken into account when selecting instantaneous residual current circuit breakers (RCCBs) or residual current devices (RCDs).

RCCBs must be selected sensitive to DC unidirectional pulses (Class A) and insensitive to transient current pulses.

Note also that the ground leakage currents of the load will be carried by this RCCB or RCD.



CAUTION

This equipment is fitted with RFI suppression filters.

This unit complies with the limits for a Class A digital device, pursuant to Part 15 Subpart J of the FCC rules. These limits provide reasonable protection against harmful interference in a commercial environment. This unit generates, uses and radiates radio frequency energy and, if not installed and used in accordance with this instruction manual, may cause harmful interference to radio communications. This unit is not designed for use in a residential area. Operation of this unit in a residential area may cause harmful interference that the User must correct at his own expense.



WARNING

In case of fire involving electrical equipment, use only carbon dioxide fire extinguishers or those approved for use in fighting electrical fires.

Battery Compartment Precautions

Batteries are factory installed in the DC UPS module. Final battery connections will be made by Emerson after the DC UPS module is installed. **DO NOT MAKE BATTERY CONNECTIONS.** The following precautions apply to the battery compartment that is part of the DC UPS module.



WARNING

Special safety precautions are required for procedures involving handling, installing, and servicing batteries. Observe all battery safety precautions presented here and in the battery instruction manual. These precautions should be followed implicitly at all times.



WARNING

A battery can present a risk of electrical shock and high short circuit current. Servicing of batteries should be performed or supervised only by properly trained and qualified personnel knowledgeable about batteries and the required precautions.

The following precautions should be observed when working on batteries:

- Remove watches, rings and other metal objects.
- Eye protection should be worn to prevent injury from accidental electrical arcs.
- Use tools with insulated handles.
- Wear rubber gloves and boots.
- Do not lay tools or metal parts on top of batteries.
- Disconnect charging source prior to connecting or disconnecting battery terminals.
- Determine if battery is inadvertently grounded. If the battery is inadvertently grounded, remove source from ground. Contact with any parts of a grounded battery can result in electrical shock. The likelihood of such shock can be reduced if such grounds are removed during installation and maintenance (applicable to equipment and remote battery supplies not having a grounded supply circuit).
- Risk of explosion if battery is replaced with an incorrect type. When replacing batteries, replace with the same manufacturer and type, or equivalent. See your local Emerson representative for a list of approved batteries.
- Dispose of used batteries according to the instructions provided with the batteries. Do not dispose of batteries in a fire. They may explode.

In addition to the hazard of electric shock, gas produced by batteries can be explosive and sulfuric acid can cause severe burns. Do not open or mutilate batteries. Released electrolyte is harmful to the skin and eyes, and is toxic. If electrolyte comes into contact with skin, the affected area should be washed immediately with large amounts of water.



WARNING

The DC UPS module's internal batteries are connected and energized even if the DC UPS module is turned OFF. Battery disconnect fuses are provided inside the DC UPS module. To minimize the risk of injury, remove the battery disconnect fuses before any off-line servicing is performed on the unit.



WARNING

DO NOT REMOVE BATTERY STRAPS. If a battery cell is replaced, ensure the battery strap is replaced and appropriately tighten.

- Battery compartments contain non-spillable batteries.
- Keep units upright.
- Do not stack.
- Do not tilt.

Failure to heed this warning could result in smoke, fire, or electric hazard.

Call Emerson before moving DC UPS modules (after initial installation).

1.0 INSPECTING THE EQUIPMENT AND STORING FOR DELAYED INSTALLATIONS

1.1 External Inspections

1. While the DC UPS system is still on the truck, inspect the equipment and shipping container(s) for any signs of damage or mishandling. Do not attempt to install the system if damage is apparent. If any damage is noted, file a damage claim with the shipping agency within 24 hours and contact Emerson Network Power (number located on last pages of this document) to inform them of the damage claim and the condition of the equipment.
2. Compare the contents of the shipment with the bill of lading. Report any missing items to the carrier and your local Emerson representative immediately.

1.2 Internal Inspections

1. Remove any packaging material, then visually examine the DC UPS system for transit damage, both internally and externally. Report any such damage to the shipper and to Emerson immediately.
2. Check the nameplate inside the DC UPS module (located on the front top right side with front door open) to verify that the "base configuration part number" and the "configured system spec. number" correspond to the units ordered. Record the DC UPS module identification numbers and serial number in the front of this manual. This information is necessary should service be required. See **Table 1**.



NOTE

The "base configuration part number" determines how the DC UPS module is physically configured and the "configured system spec. number" determines how the DC UPS module has been set up.

3. Check for loose connections or unsecured components in the module.
4. Check for shipping damage to internal components.

1.3 Storing for Delayed Installation

If the equipment will not be installed immediately, it must be stored indoors where the humidity is no higher than 95%. The storage area must protect the DC UPS system from excessive moisture.

For optimal battery life, store at a temperature between -4°F to +77°F (-20°C to +25°C) (see **7.2 - Environmental**).



CAUTION

If the batteries must remain disconnected from the DC UPS module for more than six (6) months, the batteries must be recharged before use. To charge the batteries, the batteries must be connected to the DC UPS module and the DC UPS module must be connected to utility power and started up by qualified personnel.

Table 1 DC UPS Module "Base Configuration Part Numbers" and "Configured System Spec. Numbers"

Base Configuration Part Numbers				
Part Number	Module	Distribution Feed	Distribution	No. of AC Inputs
FAB8010542/2	Primary	Top	(22) Circuit Breaker	1
FAB8010542/1	Primary	Top	(22) Circuit Breaker	2
FAB8010542/4	Primary	Top	(6) Fuse	1
FAB8010542/3	Primary	Top	(6) Fuse	2
FAB8010540/2	Primary	Bottom	(22) Circuit Breaker	1
FAB8010540/1	Primary	Bottom	(22) Circuit Breaker	2
FAB8010540/4	Primary	Bottom	(6) Fuse	1
FAB8010540/3	Primary	Bottom	(6) Fuse	2
FAB8010543/2	Expansion	Top	(22) Circuit Breaker	1
FAB8010543/1	Expansion	Top	(22) Circuit Breaker	2
FAB8010543/4	Expansion	Top	(6) Fuse	1
FAB8010543/3	Expansion	Top	(6) Fuse	2
FAB8010541/2	Expansion	Bottom	(22) Circuit Breaker	1
FAB8010541/1	Expansion	Bottom	(22) Circuit Breaker	2
FAB8010541/4	Expansion	Bottom	(6) Fuse	1
FAB8010541/3	Expansion	Bottom	(6) Fuse	2
Configured System Spec. Numbers				
Spec. Number	Description			
582145500-M1	Primary Module			
582145500-M2	1st Expansion Module			
582145500-M3	2nd Expansion Module			
582145500-M4	3rd Expansion Module			

2.0 INSTALLATION DRAWINGS AND RECOMMENDED TOOLS AND TEST EQUIPMENT

2.1 Installation Drawings

The diagrams in this section illustrate the key mechanical and electrical characteristics of the Net-Sure ITM DC UPS system.

General Notes Applicable to All Illustrations

1. All dimensions are in inches (millimeters).
2. Minimum clearance above unit required for air exhaust is 8 in. (203mm).
3. Keep module within 10 degrees of vertical while handling.
4. Top and bottom cable entry options available.
5. Color - black.
6. Unit bottom is structurally adequate for forklift handling.
7. M12 mounting holes used for seismic anchoring or floor stand.



NOTE

If floor stand is used, the weight of the unit must be supported under all casters.

8. The Primary Module includes side panels. For installations consisting of Expansion Module(s), one side panel on the Primary Module must be removed and be placed on the end Expansion Module.
9. Leveling feet are not designed to carry the full weight of the module.
10. Finger-tighten leveler against the floor, then tighten with a wrench less than 2 turns for friction fit against floor.
11. Control wiring, output cabling, and input cabling must be run separately.
12. Aluminum and copper-clad aluminum cables are not recommended.
13. All wiring is to be in accordance with the NEC and applicable local codes.

Figure 1 Outline Drawing

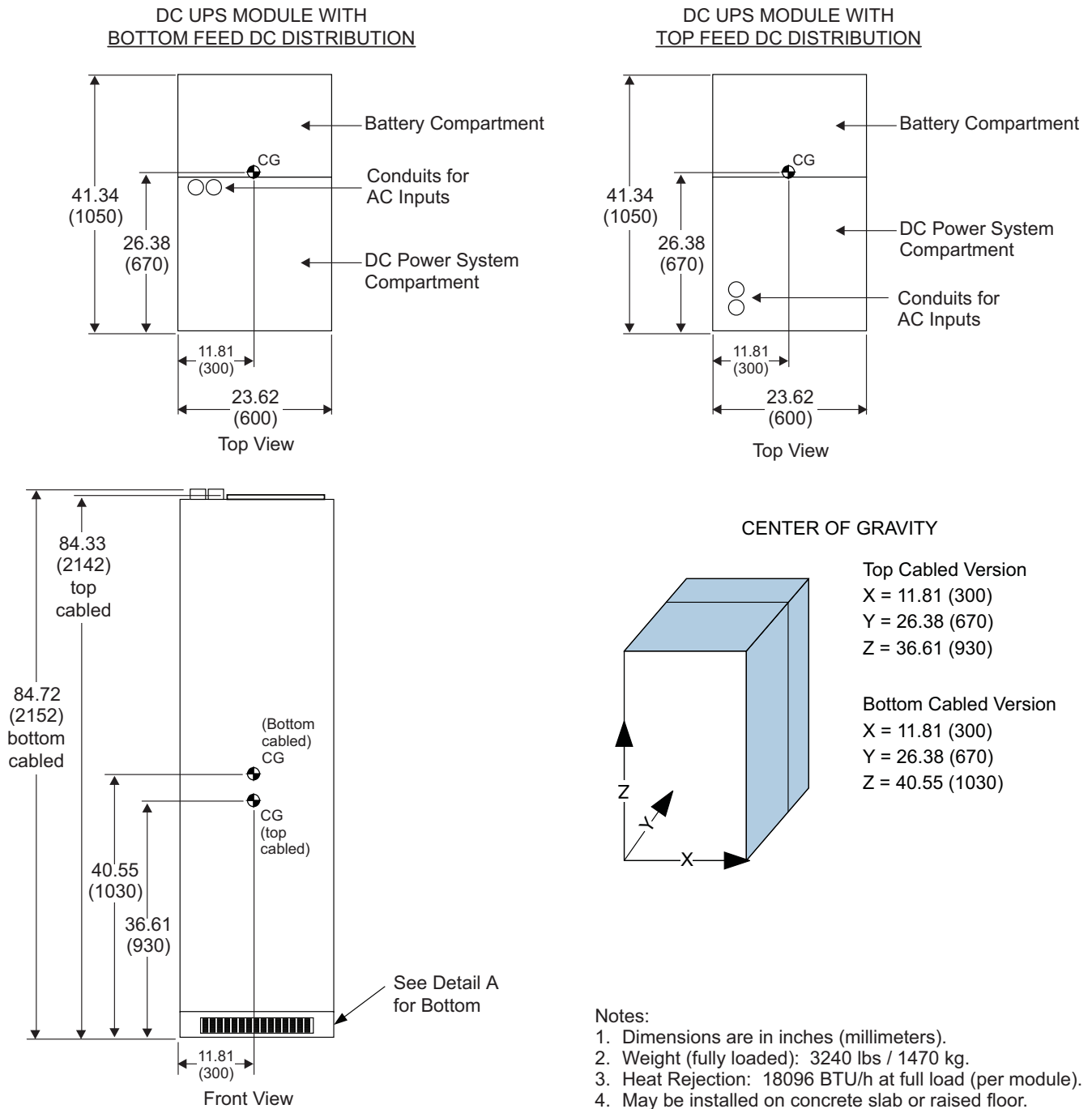
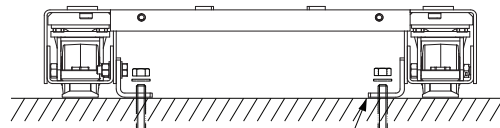

Figure 1, Detail A

ANCHORING



Anchoring bracket (4x)
used on concrete floor

(8X) Hilti HSV 1/2X4 1/2:
Item No.: 00384687

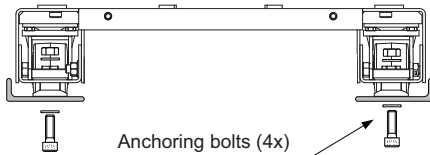

Anchoring bolts (4x)
used on raised floor

M12 x 1.75 x 70 Metric Socket Head Cap Screw.
(4X) Plain Finish with Allen Drive (hex drive) / Coarse
thread. Grade 12.9.

(4X) M12 X 1.75 Metric Hex Nuts - Grade 10.9 /
Coarse Thread / Zinc Plated.

(8X) M12 Metric Flat Washer. Grade 10.9 /
Zinc. D=28mm or 1 1/8".

Corresponding 1/2" Imperial Fasteners Can Also be Used



Hole through foot (4x) for
anchoring on raised floor

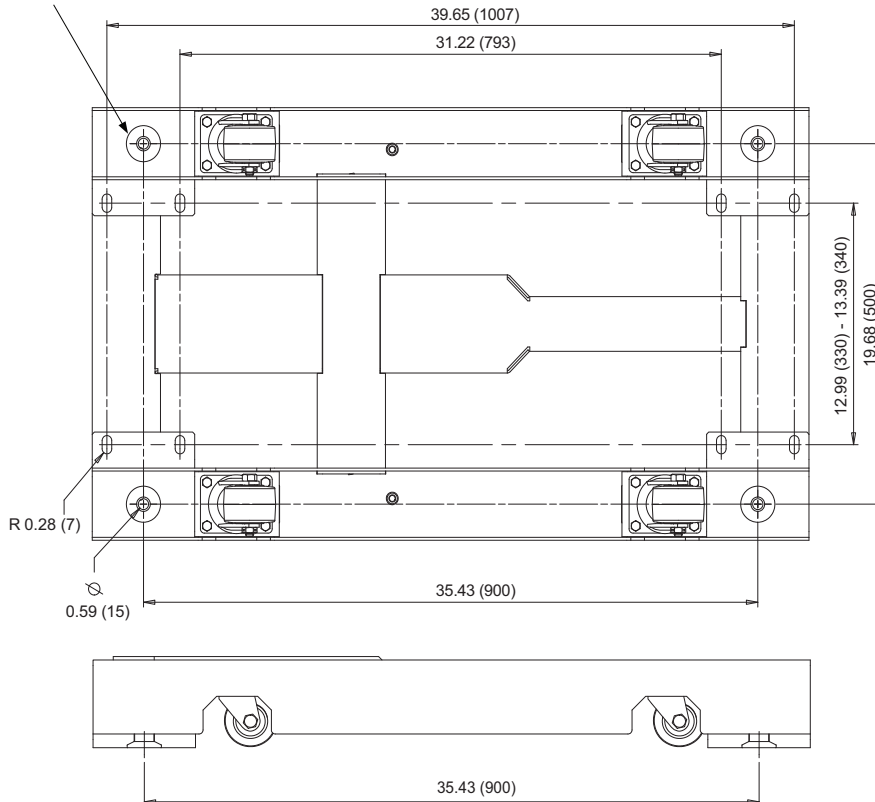

Figure 2 Bottom DC Distribution Feed Modules

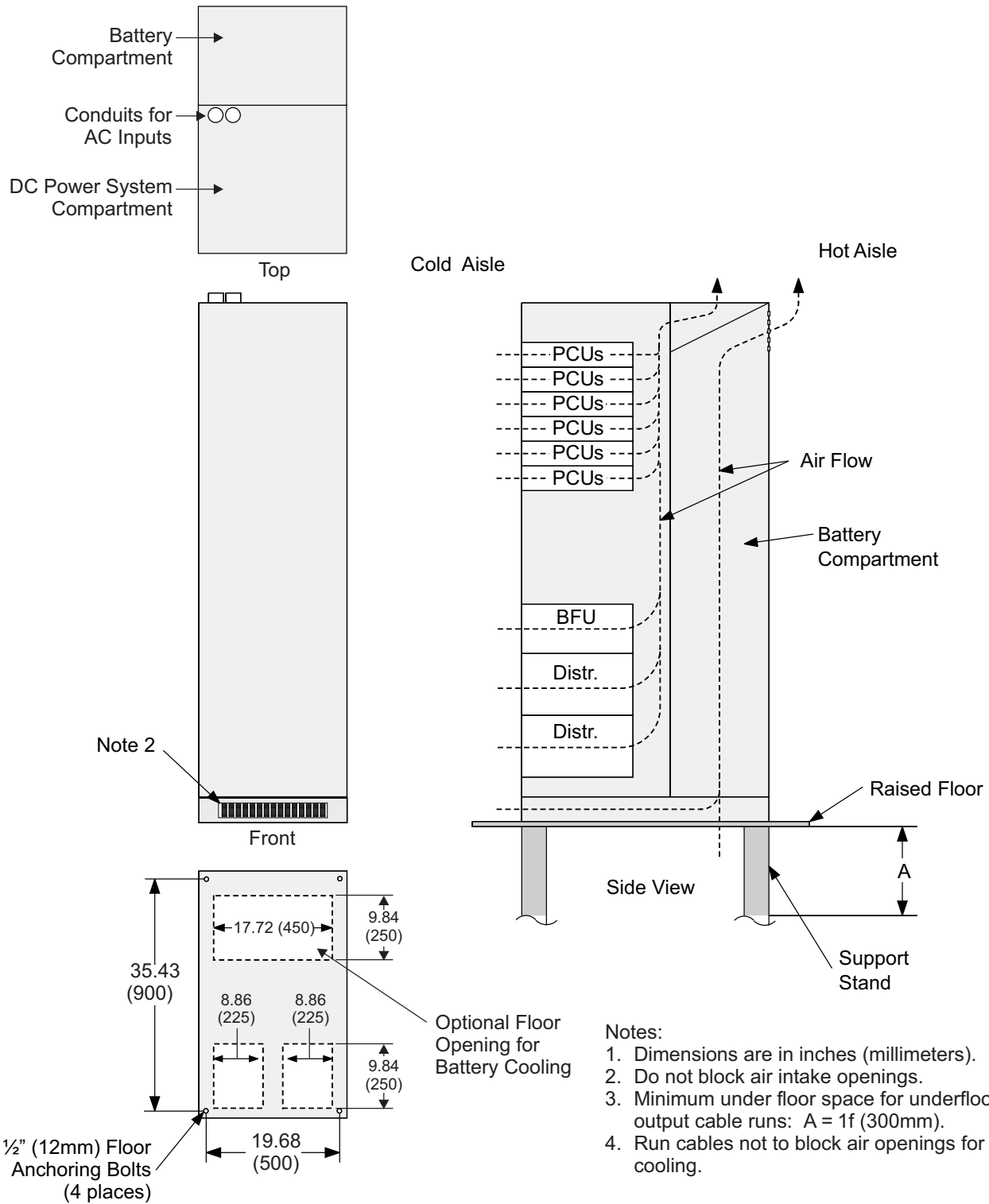
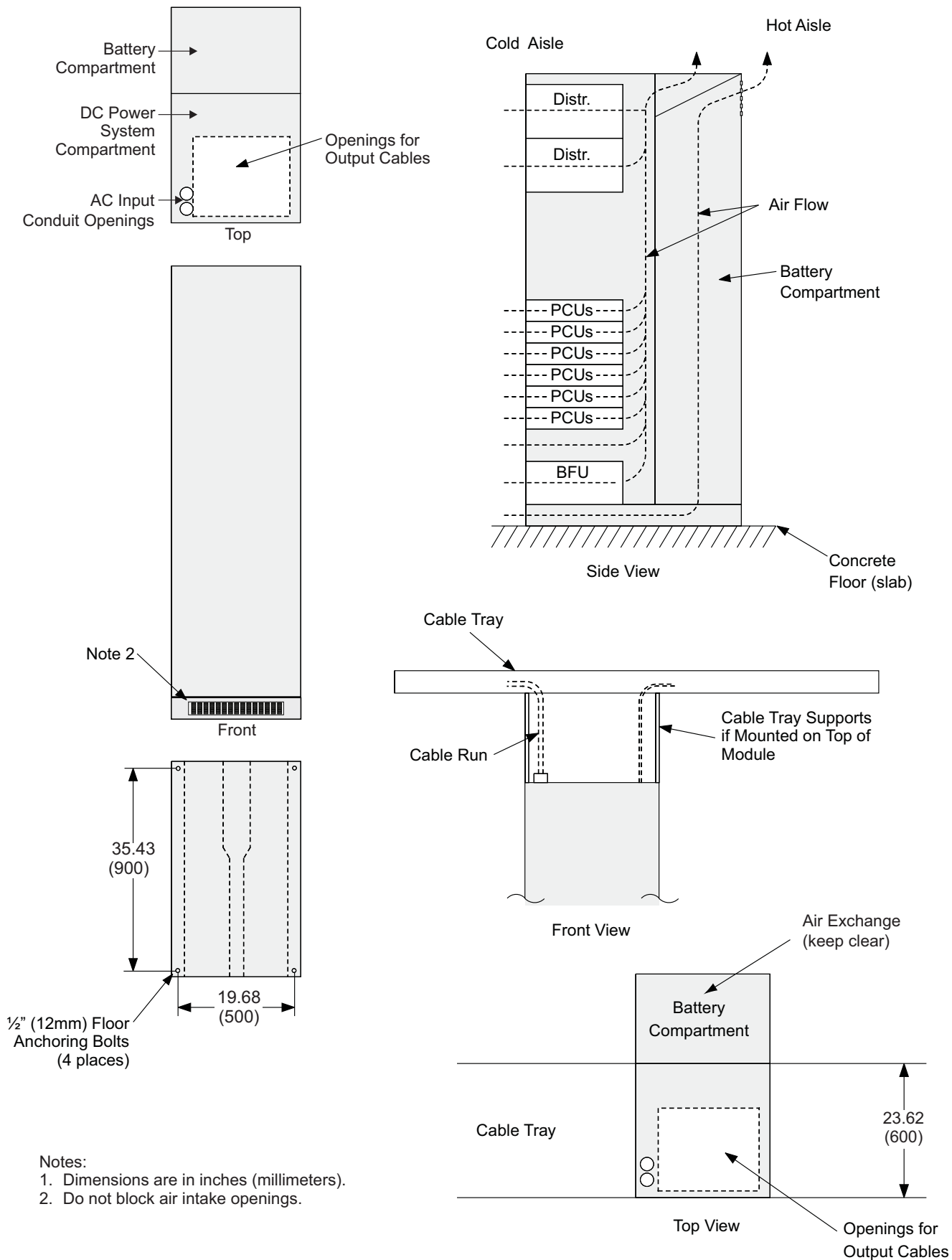

Figure 3 Top DC Distribution Feed Modules



- Notes:
1. Dimensions are in inches (millimeters).
 2. Do not block air intake openings.

2.2 Row-Based Installation Example

The NetSure ITM DC UPS system provides the flexibility to meet the needs of any data center.

The NetSure ITM DC UPS system is delivered fully configured for quick and easy field installation. Multiple DC UPS modules can easily be connected on site in order to increase capacity. Each module takes only 24" (w) x 41" (d) of floor space, including batteries and primary distribution. The NetSure ITM DC UPS system is typically installed in the middle or at the end of a row of server racks. This makes the system uniquely flexible and scalable. Deploy only the capacity that is initially needed; modules can be added at any time to any row configuration on the data center floor.

Figure 4 depicts a top distribution feed installation powering IT racks. Depending on your site and budget requirements, the NetSure ITM DC UPS solution can either be installed as a single deployment, or incrementally by row. In either scenario, DC distribution cabling to each rack is reduced by placing the NetSure ITM DC UPS in-the-row.

Whatever the physical layout of your data center, the NetSure ITM DC UPS allows for maximum space for IT equipment. With DC UPS building block modules, you can mix and match configurations and standard layouts to fit your available space.

Figure 4 NetSure™ ITM Row-Based DC UPS System Installation Example

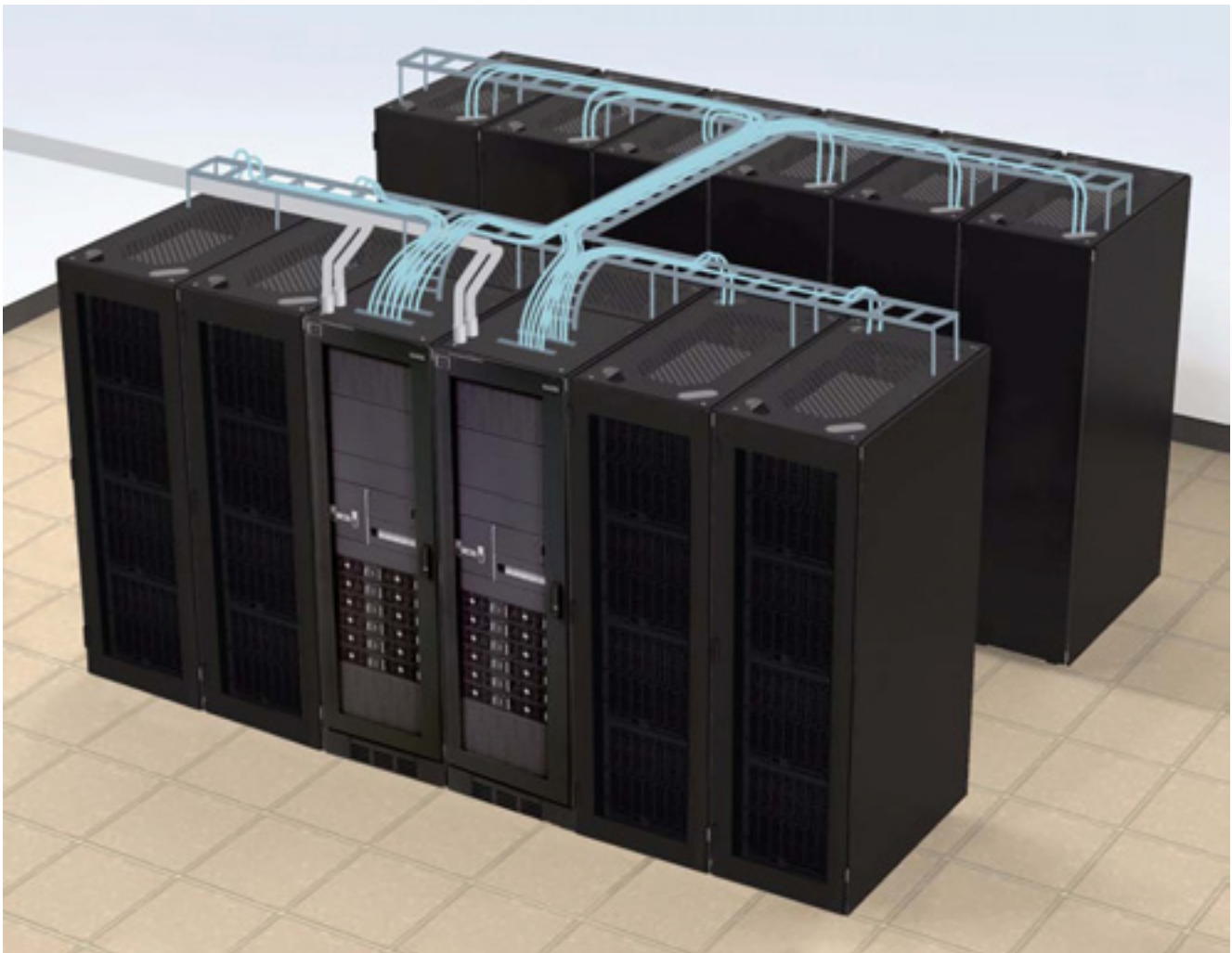

2.3 Recommended Tools and Test Equipment

The following tools and test equipment are recommended to install the DC UPS modules.

- Non-Contact Voltage Detector
- Digital Multimeter (DMM), 0 to 60 V dc, 0 to 600 V ac
- NO-OX-ID-A or Approved Equivalent
- Lineman's Scissors
- Lineman's Strippers
- Lineman's Cutters
- Electrician's Insulated Screwdrivers, Phillips, No. 1 and 2
- Electrician's Insulated Screwdrivers, Flat-Blade, Small and Large
- Adjustable Torque Wrench, 1/2" Drive, 0 in-lb to 800 in-lb
- Ratchet, 1/2" Drive
- Insulated Nut Driver Set
- Crimping Tool with Dies from 350 kcmil to 2 AWG
- Torx Screwdrivers or Bits: TX10 and TX20
- 17 mm Wrench or Socket for M10 Bolts and Nuts (for circuit breaker distribution)
- 19 mm Wrench or Socket for M12 Bolts and Nuts (for fuse distribution)
- 24 mm Wrench for Pallet.
- Hexagonal mm Bit for the Air Duct.
- Hexagonal Bit for the AC Input Breaker.

3.0 POSITIONING THE DC UPS SYSTEM

This section describes the environmental and mechanical considerations that must be taken into account when planning the positioning and cabling of the DC UPS system. This section also provides procedures for physical installation of the DC UPS cabinet.

Because every site is unique, some subsections present a guide to general procedures and practices that should be observed by the installing engineer, rather than step-by-step installation instructions.

3.1 General Requirements

- The installer should be familiar with the installation requirements and techniques to be used in securing the DC UPS module (cabinet) to the floor. It is up to the customer to determine the requirements for anchoring the cabinet to the specific type of floor at the site, select proper anchors, and to investigate the proper use of the anchor.
- This product is intended only for installation in a Restricted Access Location on or above a non-combustible surface.
- Front and rear access is required for installation and operation (see **Clearances** in this section).

3.2 General Guidelines for Positioning the DC UPS Modules

Choose a location for the DC UPS system that offers:

- Easy connection to inputs, outputs, and alarms.
- Air circulation sufficient to expel heat produced by the DC UPS system.
- Protection against moisture and excessive humidity.
- Protection against dust and other particulate matter.
- Enough space to service the DC UPS system (see **Clearances** in this section).
- Compliance with fire prevention regulations and practices.

3.2.1 Cable Entry

DC distribution and alarm cables enter the DC UPS module from the top or bottom, depending on module configuration (top distribution feed or bottom distribution feed).

AC input cables can enter either at the top or bottom. Conduit openings are provided in both locations.

3.2.2 Environmental Considerations

Before installing the DC UPS system, verify that the room satisfies the environmental conditions stipulated in **7.2 - Environmental**, paying particular attention to the ambient temperature and air exchange system. Also refer to **7.2 - Environmental** for details on heat dissipation.

The DC UPS system should be installed in a cool, dry, clean-air environment with adequate ventilation to keep the ambient temperature within the specified operating range +23°F to +95°F (-5°C to +35°C).

- Batteries are installed in the DC UPS module's battery compartment. Temperature is a major factor in determining battery life and capacity. Battery manufacturers recommend an operating temperature of 77°F (25°C). Ambient temperatures higher than this reduce battery life; temperatures lower than this reduce battery capacity. For optimal battery performance and service life, inlet air temperature to the battery compartment (from the front of the system) should be maintained between **+68°F to +77°F (+20°C to +25°C)**.

The DC UPS module is cooled by internal fans. Cooling air enters the system through the front of the unit and is exhausted out the top. To permit proper air flow and prevent overheating, do NOT block or cover the ventilation openings or blow air down onto the unit. Ventilation clearance above the unit must be a minimum of 8 in. (203mm).

3.2.3 Mechanical Considerations

The DC UPS system can be comprised of up to four (4) modules (cabinets), depending upon your power requirements. All modules used are the same size and are designed to be positioned side-by-side to form an aesthetically appealing equipment suite. The system always contains one (1) Primary Module. For increased power demands, up to three (3) Expansion Modules may be added. Locate the Primary Module at the far left or far right of the row. Remove the side panel from the Primary Module from the side that will face adjacent Expansion Modules. Place the first Expansion Module next to the Primary Module. Place additional Expansion Modules (if required) next to each other. Install the side panel removed from the Primary Module to the open side of the last Expansion Module in the row.



NOTE

*When the DC UPS system consists of multiple modules, the switches inside the modules are pre-set at the factory to identify the module as the Primary Module, 1st Expansion Module, 2nd Expansion Module, or 3rd Expansion Module. When placing modules, refer to the nameplate identification number (see **Table 1**) to ensure the Primary Module is placed on the end, and Expansion Modules are placed in sequential order.*

Clearances

There are no ventilation grilles on the sides of the DC UPS module. The DC UPS modules may be placed with the sides touching or against a wall.

To enable routine tightening of power terminations within the DC UPS module, make sure there is sufficient clearance in front and rear of the DC UPS module to permit free passage of personnel and that the front door can be fully opened.

Leave a minimum of 8 in. (203mm) between the top of the DC UPS module and the ceiling to permit adequate air circulation above the unit. Emerson recommends against using air conditioning or other systems that blow air onto the top of the unit.

Leave a minimum of 36 in. (914 mm) between the back of the DC UPS module and a wall to permit adequate air circulation for the battery compartment fans and facilitate maintenance access.

3.3 Floor Installation

Refer also to **3.1 - General Requirements**.

The diagrams in **2.0 - Installation Drawings and Recommended Tools and Test Equipment** show the location of holes in the base plate for bolting the DC UPS module to the floor.

If the module is to be placed on a raised floor, it should be mounted on a floor stand that will support the equipment point loading. Refer to the cabinet-bottom views in **2.0 - Installation Drawings and Recommended Tools and Test Equipment** to design this pedestal. Contact your ENP Sales Representative for a floor stand designed for this system (see **Figure 5**).

Figure 5 Emerson Floor Stands

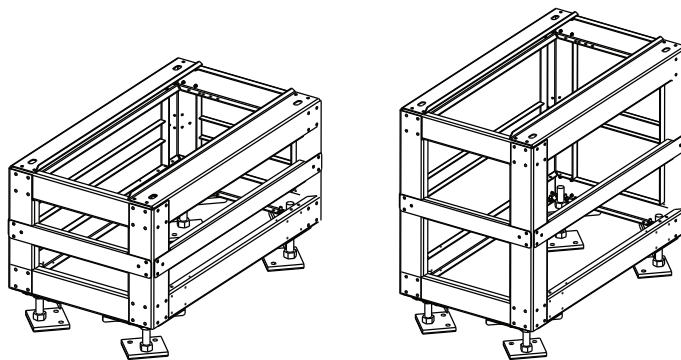

P/N 547822
24" Tall Floor Stand

P/N 547823
36" Tall Floor Stand

3.4 Considerations in Moving the DC UPS Module

3.4.1 Transporting

Ensure that the DC UPS module weight is within the designated surface weight loading (lb./ft² or kg/cm²) of any handling equipment. The DC UPS module weighs 3240 lb. (1470 kg), fully loaded.



WARNING

Ensure that any equipment that will be used to move the DC UPS module has sufficient lifting capacity. Ensure adequate personnel and lifting equipment are available when taking the module off its shipping pallet. The module presents a tipping hazard. Do not tilt the module further than 10 degrees from vertical.

The DC UPS module is fitted with casters. Take care to prevent movement when unbolting the module from its shipping pallet. The casters are strong enough for movement across even surfaces only. Casters may fail if they are subjected to shock loading, such as being dropped or rolled over holes in the floor or obstructions. Such failure may cause the unit to tip over, injuring personnel and damaging the equipment.



WARNING

Batteries are factory installed in the DC UPS module's battery compartment. Care must be taken when maneuvering modules with batteries. Keep such moves to a minimum. See **Battery Compartment Precautions on page 2**.

3.4.2 Moving a DC UPS Module

Cabinet Preparation

1. Inspect the cabinet as described in **1.1 - External Inspections** and **1.2 - Internal Inspections**.
2. Remove the front and rear bottom panels to gain access to the bolts securing the cabinet to the pallet.

Moving DC UPS Module from Shipping Pallet

Use lifting equipment, such as a forklift or similar equipment, appropriately rated for the weight of the load to move the DC UPS cabinet from its shipping pallet.

When moving a DC UPS cabinet with a forklift or similar equipment, make sure that the fork is of sufficient length for the pallet size and capable of lifting the cabinet. Also use a forklift with adjustable forks or a narrow type.

1. Close the front door.
2. Slide the forklift into place.
3. Unbolt the cabinet from the pallet.
4. Lift the cabinet. The pallet should drop off from its own weight.
5. Carefully move the DC UPS module to its installation location or set the DC UPS module down on its casters if it is to be rolled into position.

Moving DC UPS Module to Installation Location

The DC UPS module may be rolled on its casters when moving the unit a short distance. For longer distances, move the DC UPS module with a forklift or similar equipment to ease the relocation and to reduce vibration.

3.4.3 Final Positioning

Note that the DC UPS modules sit on four casters. When the DC UPS module has been finally positioned, ensure that the adjustable stops are set so that the DC UPS module will remain stationary and stable.

3.5 Overhead Cable Tray Rails

Refer to **Figure 6** for mounting locations for overhead cable tray rails.

Figure 6 Mounting Locations for Overhead Cable Tray Rails

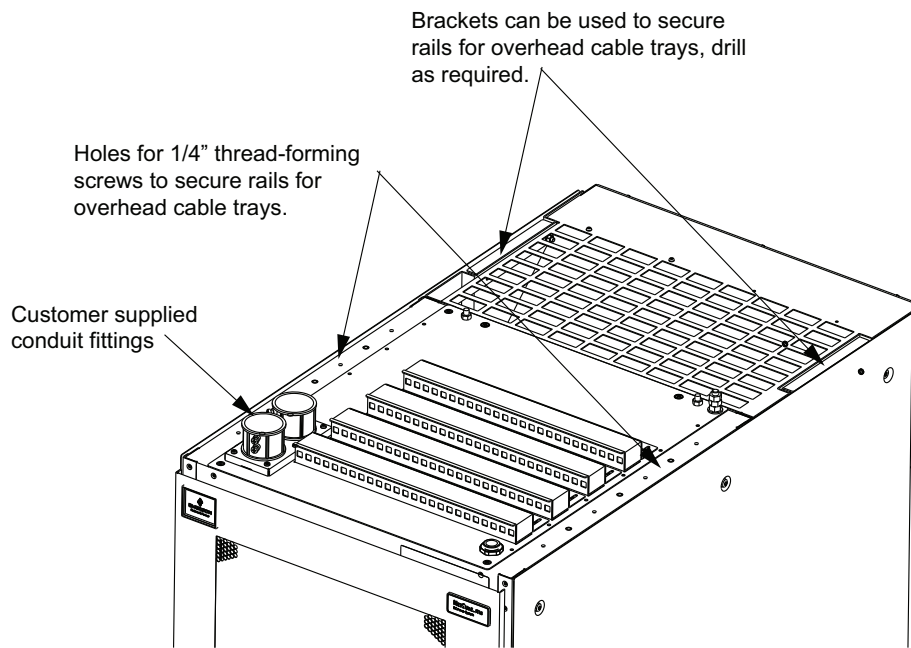

3.6 For Top DC Distribution Feed (Top Cabled) Modules Only: Installing the Supplied Air Duct Assembly

The Air Duct Assembly must be installed in DC UPS modules configured for top DC distribution feed (top cabled). The Air Duct Assembly allows air to be drawn from the bottom front of the DC UPS module and up into the battery compartment for cooling. Refer to **Figure 7**, and install the supplied Air Duct Assembly.

Figure 7 Installing Air Duct Assembly

Note: If AC power cables are fed from the bottom, install AC power cables before installing air duct.

Note: The rubber parts of the air duct assembly may be lubricated with water before sliding the air duct halves into place.

Procedure:

- 1) Remove bottom front and rear panels from the DC UPS module.
- 2) Partially slide the half of the air duct assembly with vents into the front bottom compartment of the DC UPS module (power compartment bottom).
- 3) Install and secure the supplied bracket with the supplied screws.
- 4) Slide the half of the air duct assembly with vents completely into the DC UPS module, and secure with the supplied screws.

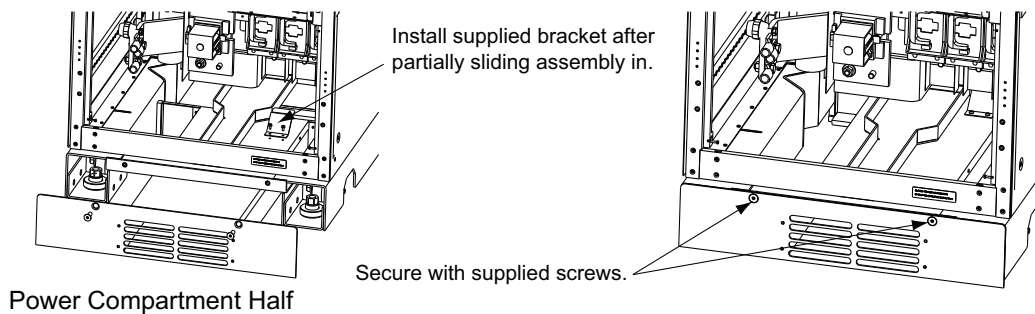

- 5) Slide the remaining half of the air duct assembly into the rear bottom compartment of the DC UPS module (battery compartment bottom).
- 6) Secure the air duct half just installed with the supplied screws.

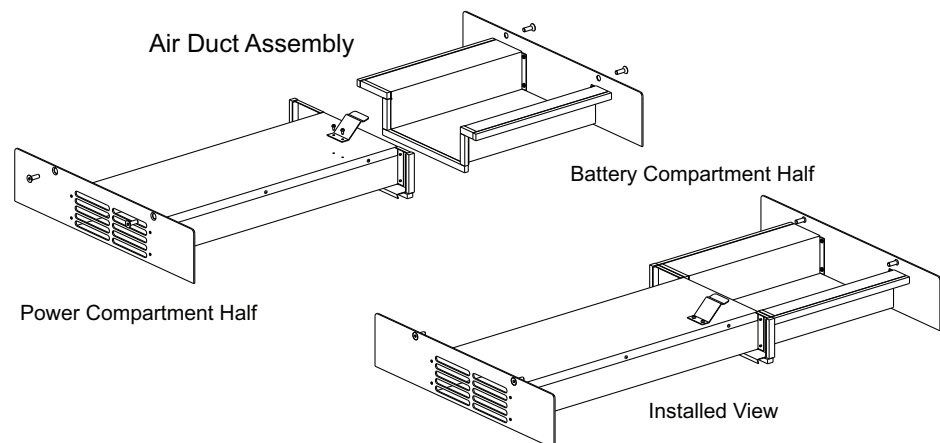
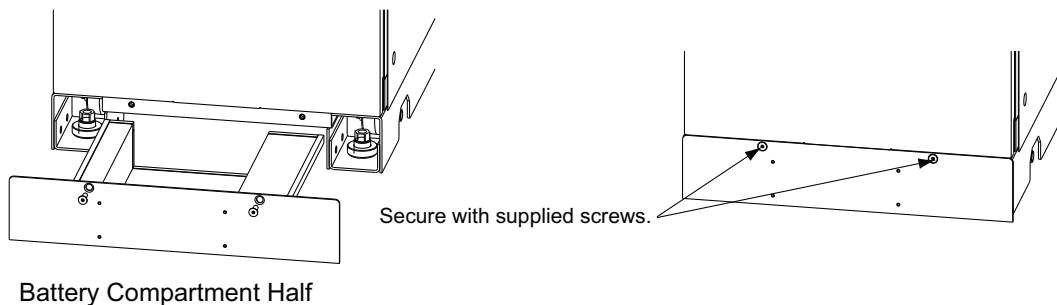

4.0 ELECTRICAL CONNECTIONS

The DC UPS system requires grounding, DC output distribution, AC input power, alarm/control, and battery wiring once it has been mechanically installed.

If the system consists of multiple DC UPS modules, battery and ground/return busbars must be interconnected and alarm/control interconnect wiring between modules must be made.

4.1 Wiring Information and Guidelines

4.1.1 Cable Lengths (Floor or Cabinet Top to Connection Point Inside DC UPS Module)

To help calculate the total cable length required, refer to **Table 2** for the distance from the floor or cabinet top to selected connection points inside the DC UPS module. Determine the cable length required to reach the DC UPS module, then add the appropriate length from the table and adequate slack for repair and maintenance.

Table 2 Distance to Connection Points inside the DC UPS Module

Connection Point inside DC UPS Module	Distance - Bottom DC Distribution Feed Module		Distance - Top DC Distribution Feed Module	
	From Floor in. (mm)	From Top of Module in. (mm)	From Floor in. (mm)	From Top of Module in. (mm)
AC Input	79 (2000)	138 (3500)	157 (4000)	59 (1500)
DC Output	28 (700)	N/A	N/A	28 (700)
Grounding	79 (2000)	138 (3500)	157 (4000)	59 (1500)
Alarm/Control	59 (1500)	N/A	N/A	47 (1200)

4.1.2 Recommended Wire Sizes, Recommended Lugs, and Torque Requirements

The main factors affecting the choice and size of wires are voltage, current (also taking into account overcurrent), room temperature, and installation conditions.

The power cables of the system must be sized with respect to the following:

- **AC Input Cables** - The AC input cables must be sized for the module's maximum input current.
- **DC Output Distribution Cables** - The DC output distribution cables must be sized for the module's output breakers or fuses.
- **Battery Cables** - The DC UPS module contains a battery compartment. Battery cables are factory supplied and sized accordingly.

Refer to **Termination Type, Recommended Wire Size, Recommended Lugs on page 48** for recommended wire sizes and recommended lugs. Refer to the illustrations in this section for torque requirements.



NOTE

The above referenced section gives nominal currents for determining the size of DC UPS module power cables. Other important factors to consider include cable route length and coordination with protective devices.

4.1.3 Wiring Guidelines

The following are guidelines only and are superseded by the NEC and applicable local codes where applicable.

- The grounding cable connecting the DC UPS module to the main ground system must follow the most direct route possible.
- Consider using paralleled smaller cables for heavy currents—this can ease installation.

- When laying power cables, do not form coils; this will help avoid increasing formation of electro-magnetic interference. Positive and negative cables should be run together.
- Alarm/control wiring and power wiring must be run separately. Output and input cables must be run separately.

4.2 Protective Covers

Wiring connection access requires removing protective covers from the DC UPS module. When making electrical connections, remove the appropriate protective cover, as shown in **Figure 8**.

Replace all protective covers after all electrical connections have been made and checked.

Figure 8 Protective Covers

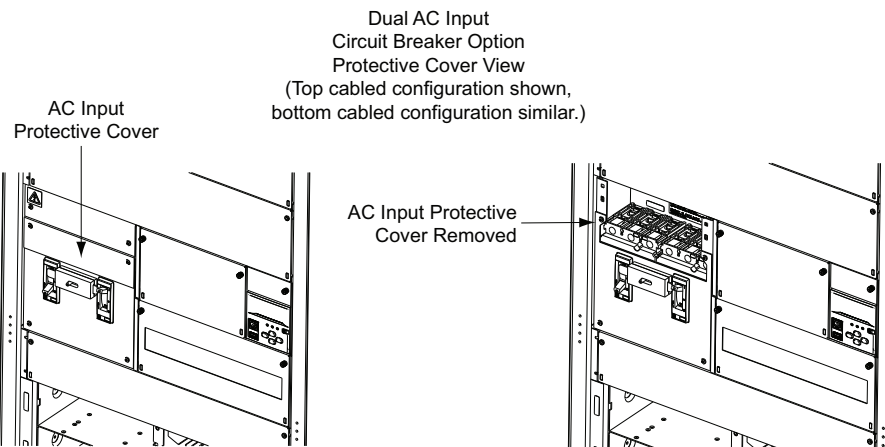
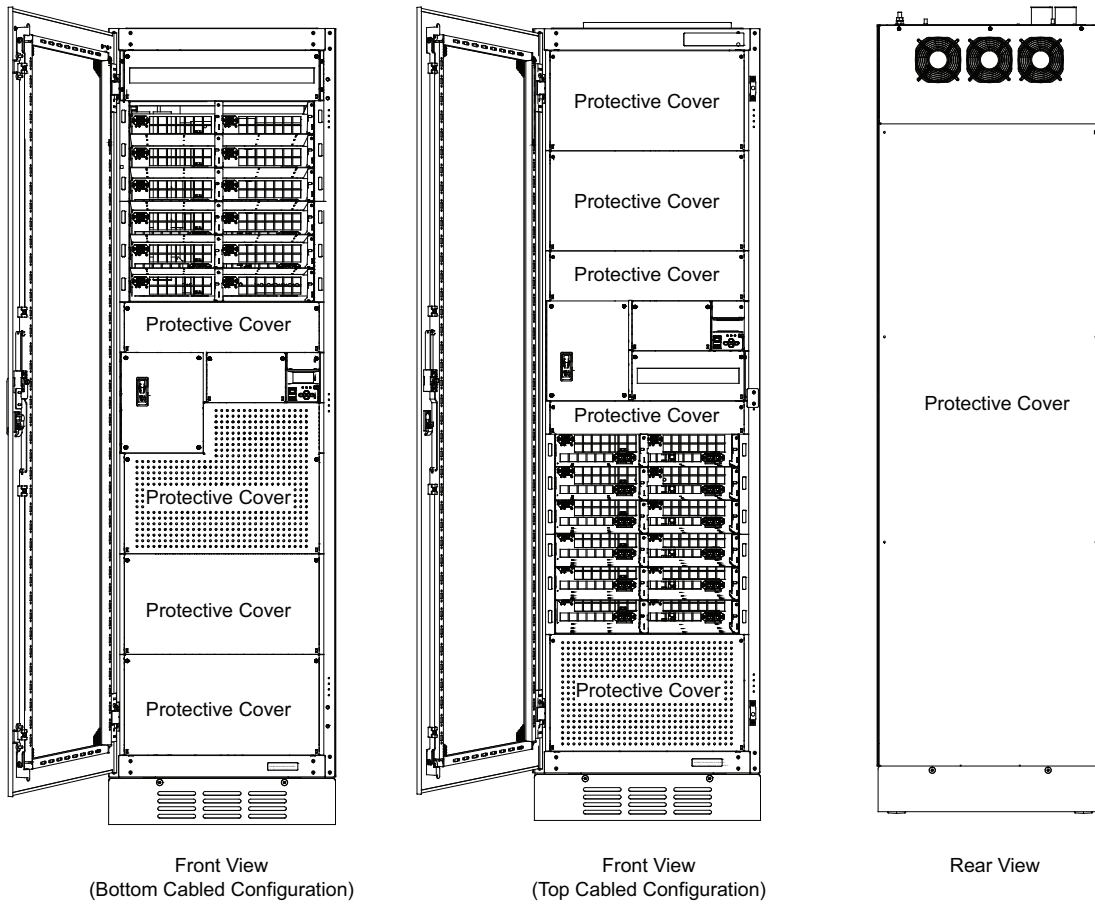

4.3 Wiring Connections Locations

The DC UPS module input and output cable connections are easily accessible from the front of the unit for installation. Refer to **Figure 9**, **Figure 10**, **Figure 11**, **Figure 12**, **Figure 13**, **Figure 15**, **Figure 16**, **Figure 17**, and **Figure 18** for connection locations. The DC UPS module contains a battery compartment. Battery cables are factory supplied and connected to the DC UPS module. Final connections to the batteries are made in the procedure in **6.2 - Final Battery Connections**. Battery connections are done from the rear of the DC UPS module.

Figure 9 Wiring Connections Locations (DC UPS Module with Bottom Feed DC Distribution)

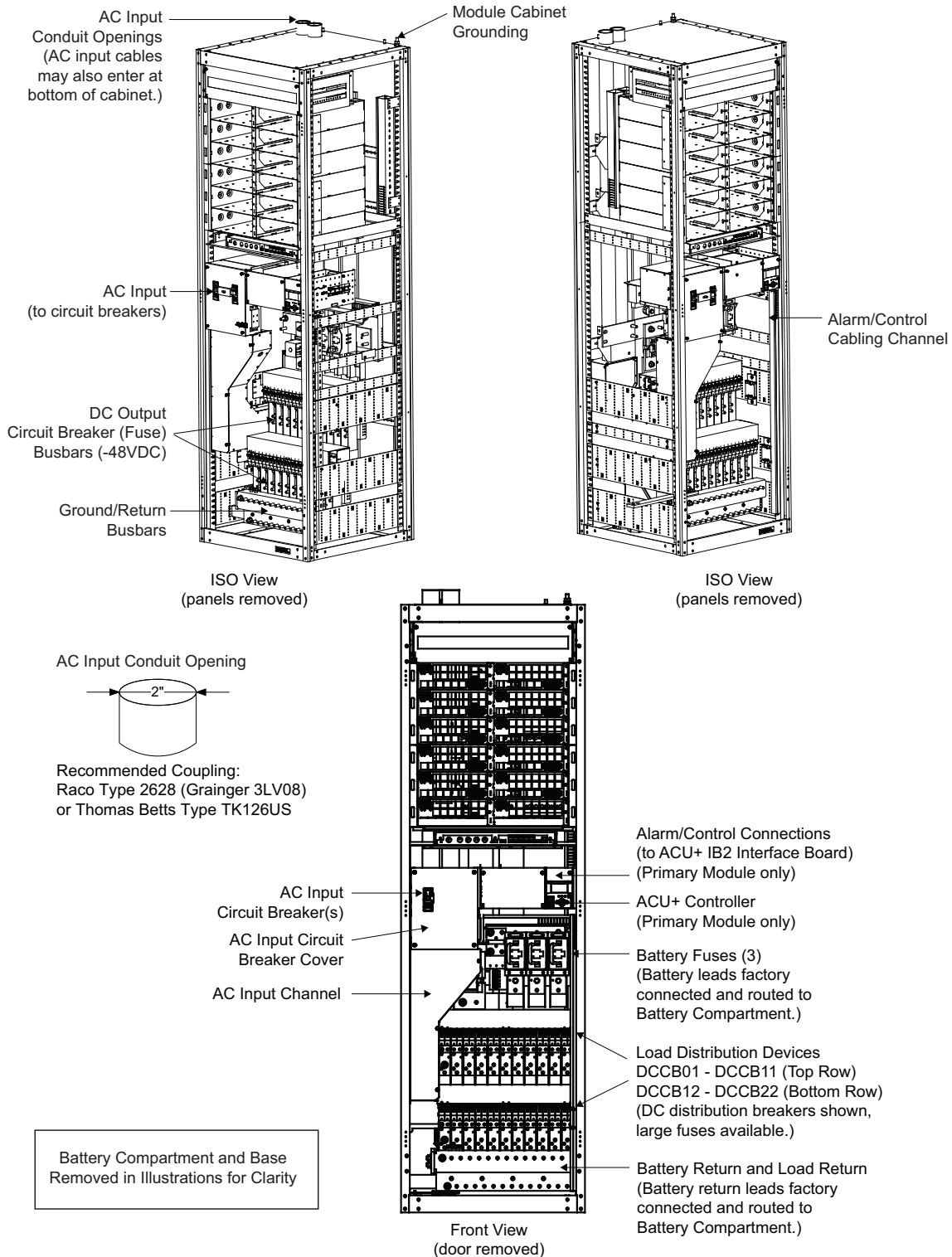
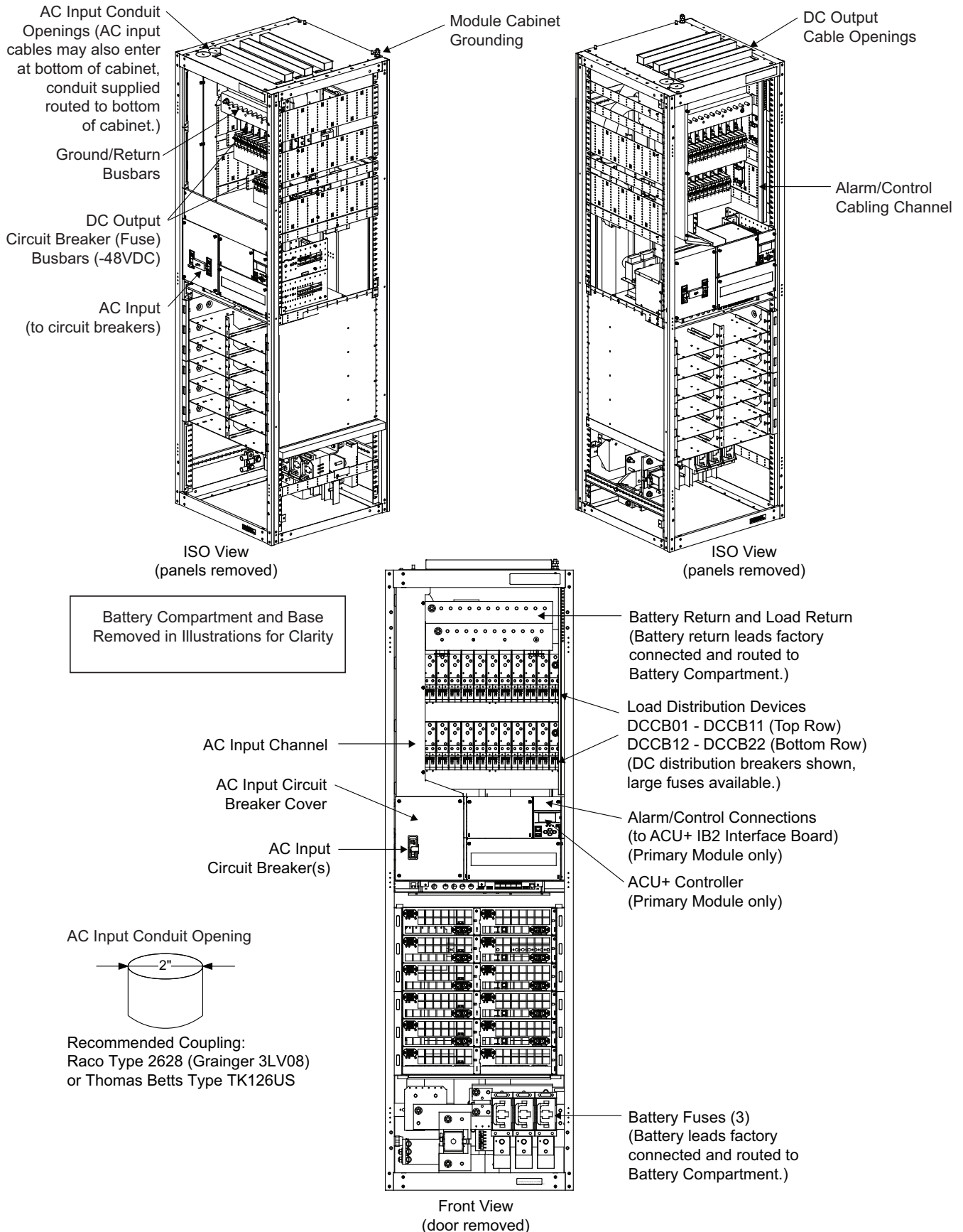

Figure 10 Wiring Connections Locations (DC UPS Module with Top Feed DC Distribution)



4.4 Making Electrical Connections



CAUTION

The electrical connections described in this section must be performed by authorized electricians or qualified technical personnel. Follow the NEC and applicable local codes. If you have any difficulties, contact your local Emerson representative or Emerson Services.

Before making electrical connections, do the following for each DC UPS module.

- Open the front door. For bottom cable installations, remove the lower front panel. For all installations, remove protective panels as required (see **4.2 - Protective Covers**).
- Ensure the main AC input circuit breaker(s) is in the OFF position.
- Ensure all PCU AC input circuit breakers are in the OFF position.
- Ensure the three (3) battery disconnect fuses are removed.
- Ensure all distribution circuit breakers are in the OFF position or distribution fuses are removed.

4.4.1 Cabinet Grounding Connection

The cabinet grounding connection is made to a stud located on the top of the DC UPS module, as shown in **Figure 11**. A cabinet grounding cable must be connected to this stud, per site requirements. Tighten the connection to the torque indicated in **Figure 11**.

Each module also contains a separate stud located on each side to connect the supplied grounding strap between DC UPS modules, if desired.

All modules and cable conduit should be grounded in accordance with the NEC and all applicable local codes.



WARNING

Failure to follow proper grounding procedures can result in electric shock hazard to personnel or the risk of fire, should a ground fault occur.



NOTE

Proper grounding significantly reduces electromagnetic interference problems in systems.

Figure 11 Cabinet Grounding Connection

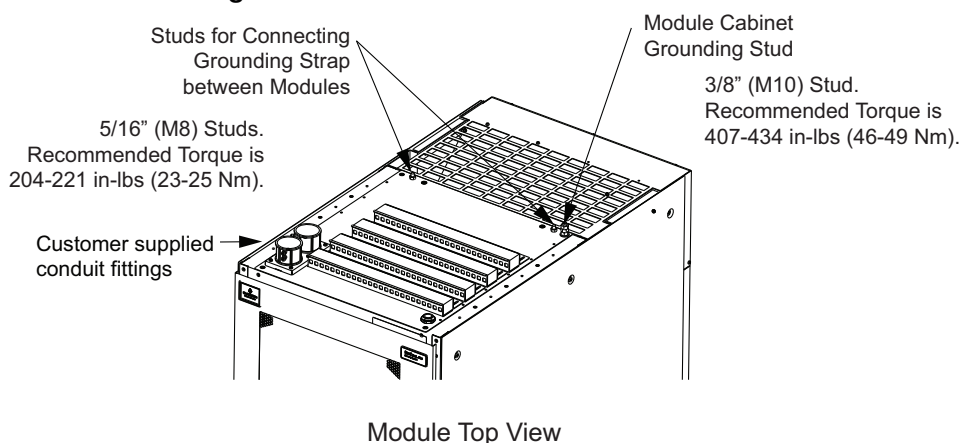

4.4.2 DC Output Distribution Connections

Connect the DC output distribution cables between the DC UPS module and the loads as required. These connections are made to the output circuit breaker or fuse busbars and the ground/return busbar, as shown in **Figure 9** or **Figure 10**. Refer to **Figure 12** for a view of the busbar terminations. Tighten the connections to the torque indicated in **Figure 12**.



WARNING

If the load equipment will not be ready to accept power on the arrival of the commissioning engineer, then ensure that the system output cables are safely isolated.

Figure 12 DC Output Connections

DISTRIBUTION CIRCUIT BREAKERS

DC UPS MODULE WITH
TOP FEED DC DISTRIBUTION

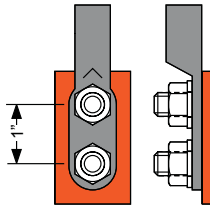

DC Output (-48Vdc)
(per distribution position)
to distribution device busbar

DC UPS MODULE WITH
BOTTOM FEED DC DISTRIBUTION

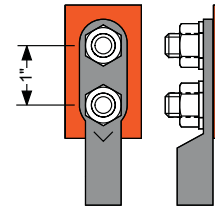

DC Output Return
(per distribution position)
to ground/return busbars

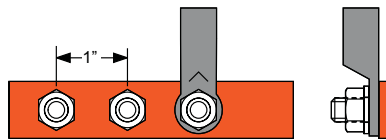
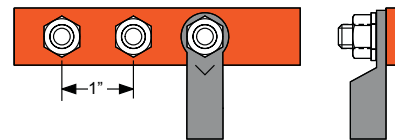

Terminals are 3/8" (M10) studs.
Recommended Torque is 407-434 in-lbs (46-49 Nm).

DISTRIBUTION FUSES
(optional)

DC UPS MODULE WITH
TOP FEED DC DISTRIBUTION

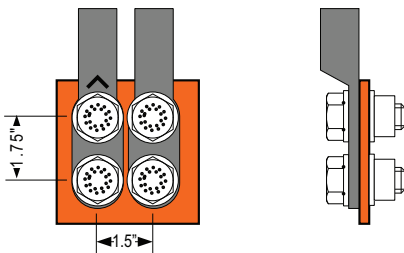

DC Output (-48Vdc)
(per distribution position)
to distribution device busbar

DC UPS MODULE WITH
BOTTOM FEED DC DISTRIBUTION

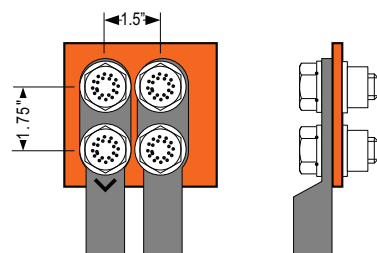

DC Output Return
(per distribution position)
to ground/return busbars

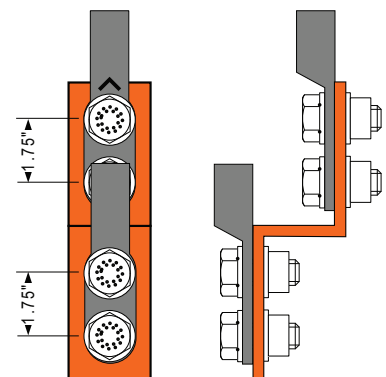
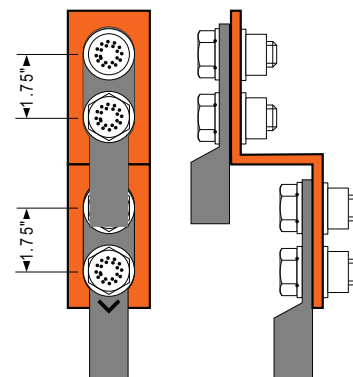

Terminals are 1/2" (M12) studs.
Recommended Torque is 690-743 in-lbs (78-84 Nm).

4.4.3 AC Input Power Connections



WARNING

AC input power connections must be performed by a qualified electrician.

Before connecting AC input cables to the DC UPS module, ensure that you are aware of the location and operation of the overcurrent protection devices that connect these cables to the power distribution panel. Before connecting AC input cables, de-energize and lockout or tagout these overcurrent protection devices.

Do not apply AC input power to the DC UPS module before the arrival of the commissioning engineer.

AC Input Overcurrent Protective Device



CAUTION

To reduce the risk of fire, connect AC input only to a circuit provided with correct amperes maximum branch circuit overcurrent protection in accordance with the NEC, ANSI/NFPA 70.

External overcurrent protection for the AC input circuit is to be provided by the customer. Refer to **AC Input Specifications on page 50** for maximum input current ratings. Each DC UPS module is provided with one or two internal 150A AC input circuit breaker.

AC Input Connections

AC input leads can enter the DC UPS module from the top or from the bottom. Refer to **Figure 13** for an AC input routing diagram. **Figure 14** provides a diagram for installing conduit fittings when AC is fed from the top.

One or two AC input breakers are provided (depending on module configuration). Refer to **Figure 15** for an AC input connections diagram. Tighten the connections to the torque indicated in **Figure 15**. Note that a cover needs to be removed to access the circuit breakers as shown in **Figure 8**.

- Connect Feed A AC input supply cables between the power distribution panel and the DC UPS module's internal Feed A input circuit breaker (Feed A: L1, L2, L3 terminals).
- If the DC UPS module is configured for two AC input feeds, connect the optional Feed B AC input supply cables between the power distribution panel and the DC UPS module's internal Feed B input circuit breaker (Feed B: L1, L2, L3 terminals).

Figure 13 AC Input Power Connection Routing Options

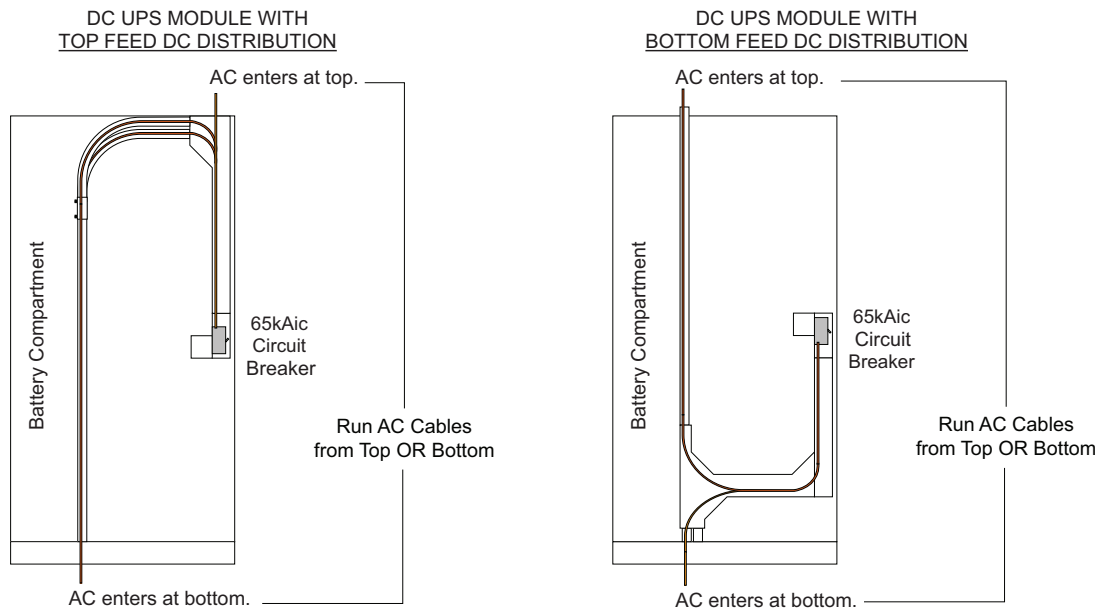

Figure 14 Installing Conduit Fittings when AC is Fed from the Top

1) Remove cover plate.

2) Install one or two customer provided conduit fittings to supplied conduit plate.

3) Secure conduit plate with conduit fittings installed to top of cabinet.

Note: Cut cover plate in half if only one conduit being installed.

Note: If only one conduit being installed, re-install plate that was cut in half.

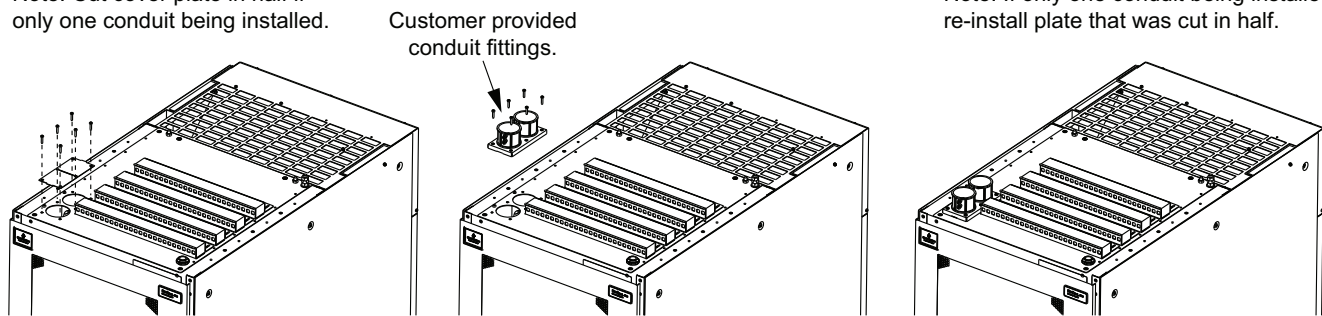
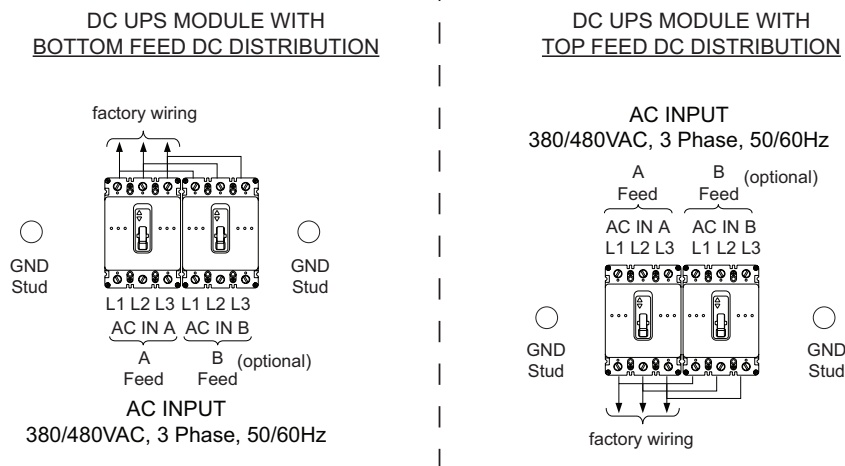

Figure 15 AC Input Power Connections



One or two AC input circuit breakers are provided (depending on module configuration).
 Two ground studs (5/16" [M8]) are provided attached to the sides of the enclosure surrounding the AC input circuit breaker(s).
 Recommended torque is 124 in-lbs (14 Nm) for AC input circuit breaker connection.
 Recommended torque is 204-221 in-lbs (23-25 Nm) to grounding studs.

4.4.4 Optional Alarm/Control Connections (to Primary Module only)

Alarm/control connections are made to the ACU+ Controller Customer Interface Board (IB2). The IB2 board provides connection points for digital inputs and relay outputs. System required connections are factory wired to the IB2 board. The customer may wire to un-used digital input and relay outputs, if desired. The IB2 board is located in an enclosure above the ACU+ Controller (see **Figure 9** or **Figure 10**). To access these connections, loosen the captive fastener on the front of the enclosure and slide the IB2 board partially out of the shelf. Note that a wireway is provided to route the wires to the IB2 board, as shown in see **Figure 9** or **Figure 10**. Connect external alarm/control wiring to terminal blocks J3-J9 of the IB2 board, as required. Refer to **Figure 16**.

Figure 16 Alarm and Control Connections

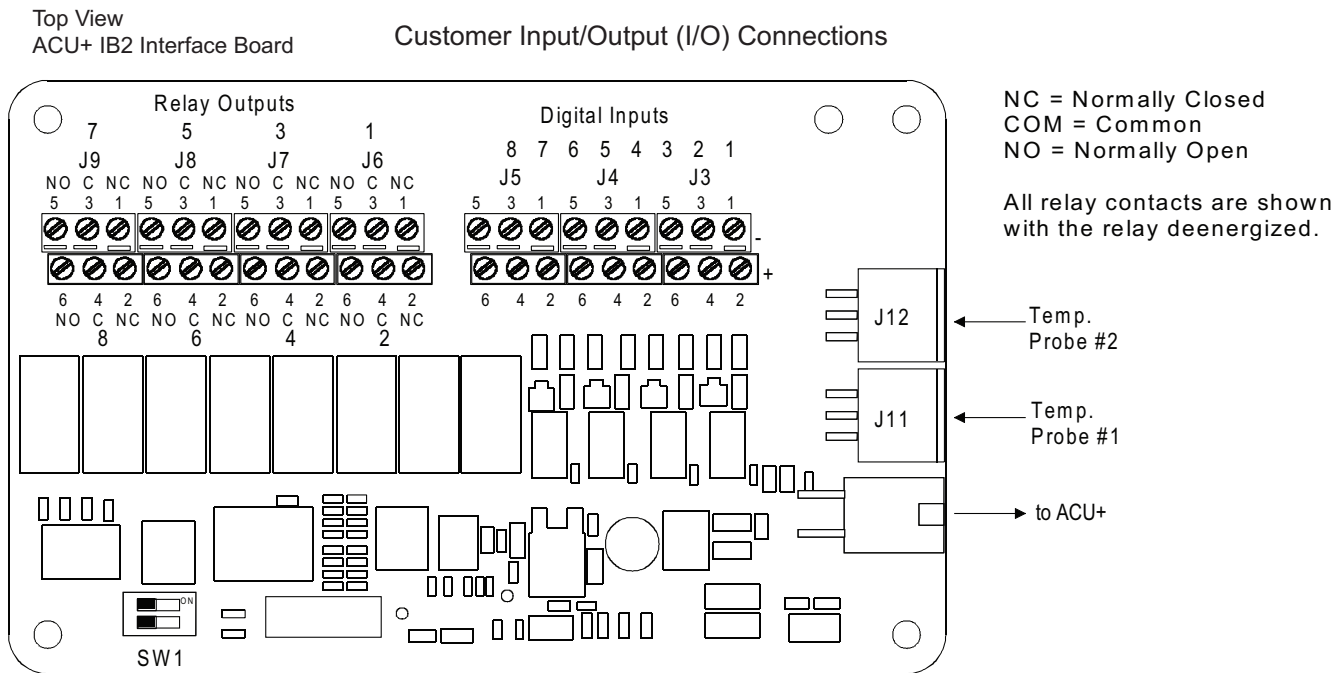

Terminals are M2 screws.
Recommended Torque is 1.92-2.16 in-lbs (0.22-0.25 Nm).
Wire size range is 26 AWG to 16 AWG (0.14 mm² to 1.0 mm²).

Digital Input Connections

Up to eight (8) digital inputs may be connected to the IB2 board. Digital inputs that have factory connections are listed in **Table 3**. A blank column in **Table 3** is also provided if you want to document custom connections to un-used digital inputs.

- Observe proper polarity per **Table 3**. For example, if alarm No. 1 uses a BR+ signal, the alarm lead must be connected on the + terminal of input 1 and a continuous -48V signal must be connected on the - terminal of input 1. Inversely, if alarm No. 1 uses a -48V signal, the alarm lead must be connected on the - terminal of input 1 and a continuous BR+ signal must be connected on the + terminal of input 1.
- The digital inputs can be configured to provide an alarm when the signal is applied (HIGH) or removed (LOW), as described in the DC UPS User Manual.

Table 3 Programmable Digital Inputs

Programmable Digital Input	Pin No.		Dedicated to...	Customer Custom Digital Input
1	J3-1	–	Available for Customer Custom Digital Input	
	J3-2	+		
2	J3-3	–	Available for Customer Custom Digital Input	
	J3-4	+		
3	J3-5	–	Available for Customer Custom Digital Input	
	J3-6	+		
4	J4-1	–	PCU EPO	factory wired
	J4-2	+		
5	J4-3	–	Fan Supply Alarm	factory wired
	J4-4	+		
6	J4-5	–	Fan Alarm	factory wired
	J4-6	+		
7	J5-1	–	Available for Customer Custom Digital Input	
	J5-2	+		
8	J5-3	–	Available for Customer Custom Digital Input	
	J5-4	+		
--	J5-5			--
	J5-6			

Relay Output Connections

The IB2 board provides eight (8) programmable alarm relays with Form-C contacts. Default relay assignments are documented in **Table 4**. A blank column in **Table 4** is also provided if you want to document a custom configuration. Alarm relay contacts are rated for 2A @ 30VDC and 0.5A @ 125VAC (60W maximum power consumption).

- Each relay can be individually configured to activate for any system alarm condition.
- Refer to DC UPS User Manual for programming instructions.

Table 4 Programmable Relay Outputs

Programmable Relay Output	Pin No.		Alarms Assigned to this Relay (Default)	Alarms Assigned to this Relay (Custom)
1	J6-5	NO	All alarms programmed with alarm severity of "major alarm". Relay de-energizes during an alarm condition.	
	J6-3	COM		
	J6-1	NC		
2	J6-6	NO	All alarms programmed with alarm severity of "minor alarm". Relay de-energizes during an alarm condition.	
	J6-4	COM		
	J6-2	NC		
3	J7-5	NO	All alarms programmed with alarm severity of "observation alarm". Relay energizes during an alarm condition.	
	J7-3	COM		
	J7-1	NC		
4	J7-6	NO	Available for Customer Custom Setting	
	J7-4	COM		
	J7-2	NC		
5	J8-5	NO	Available for Customer Custom Setting	
	J8-3	COM		
	J8-1	NC		
6	J8-6	NO	Available for Customer Custom Setting	
	J8-4	COM		
	J8-2	NC		
7	J9-5	NO	Available for Customer Custom Setting	
	J9-3	COM		
	J9-1	NC		
8	J9-6	NO	Available for Customer Custom Setting	
	J9-4	COM		
	J9-2	NC		

IB2 Board DIP Switch Settings (for reference only)

Dip Switch SW1 on the IB2 board is used to set the communications address for this board (**Table 5**). In this system, both switches of SW1 are to be set in the OFF position. Refer to **Figure 16** for SW1 location.

Table 5 IB2 Board Communications Address Settings

DIP Switch SW1		Board Number
1	2	
OFF	OFF	1
ON	OFF	2
OFF	ON	3
ON	ON	na

IB2 Board LED Indicators (for reference only)

The IB2 board has a green LED indicator which is lit in normal operation and flashes when the IB2 board is communicating with the Controller.

4.4.5 ACU + Controller Ethernet Connection (to Primary Module only)

The ACU+ Controller provides a Web Interface via an Ethernet connection to a TCP/IP network. An RJ-45 10BaseT jack is provided on the front of the ACU+ Controller for connection into a customer's network running TCP/IP. This jack has a standard Ethernet pin configuration scheme, twisted pair. Refer to **Figure 9** or **Figure 10** for location of the ACU+. Refer to **Figure 17** for location and **Table 6** for pinouts of the Ethernet port. Use shielded Ethernet cable (grounded at both ends). Note that the ACU+ Controller's RJ-45 jack is connected to chassis ground.

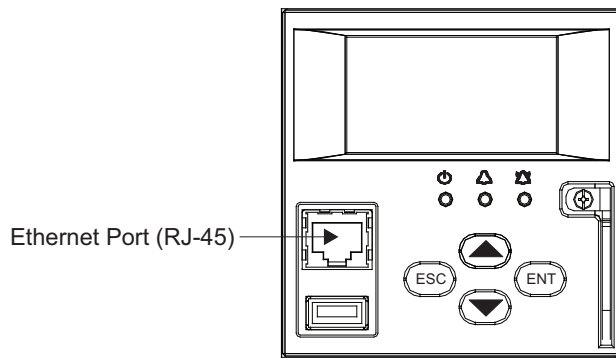
Figure 17 ACU+ Controller RJ-45 Ethernet Port**Table 6 ACU+ Controller RJ-45 Ethernet Port**

Port Pin Number	Name	Definition
1	Tx+	Write Signal +
2	Tx-	Write Signal -
3	Rx+	Read Signal +
4	--	no connection
5	--	no connection
6	Rx-	Read Signal -
7	--	no connection
8	--	no connection

4.4.6 Optional Emergency Power Off (EPO) Connection (to Primary Module only)

The DC UPS module has an Emergency Power Off (EPO) function operated by a remote contact provided by the User.

If the EPO function is desired, locate the EPO jumper in the Primary Module (see **Figure 18**). Remove the EPO jumper (the jumper connects from the bottom terminal of the EPO terminal block and the bottom of EPO Fuse F11). Connect a customer provided external normally closed switch between the bottom terminal of the EPO terminal block and the bottom of the EPO Fuse.

The following occurs when the EPO switch is opened.

- The battery LVD contactor in each DC UPS module opens, disconnecting the battery from each module.
- The PCUs in each DC UPS module shut down after 5 seconds.



WARNING

The EPO circuit operates with -48Vdc. There is -48Vdc present on the terminals the EPO jumper connects to. There is -48Vdc present on these same terminals that an external EPO switch will be connected to.



NOTE

The external EPO switch wiring must be double-insulated. The wire must be 600V, 18-16 AWG stranded for maximum runs between 82 and 197 feet (25-60m), respectively.

The Emergency Stop action within the DC UPS module opens the battery LVD contactor and shuts down the PCUs. It does not internally disconnect the input power supply. To disconnect ALL power to the DC UPS module, open the upstream feeder breaker(s) when the remote EPO is activated.

Figure 18 EPO Jumper Location

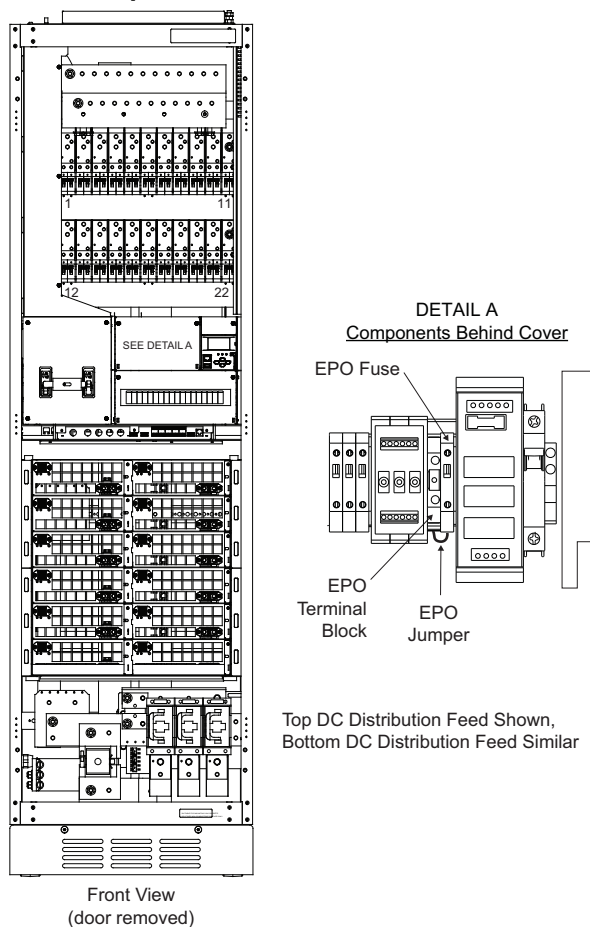

4.4.7 Battery Connections

Batteries are factory installed and connected. Final connections to the batteries are made in the procedure presented in **6.2 - Final Battery Connections**.

4.5 Making Module-to-Module -48VDC and Ground/Return Interconnections (if system consists of multiple DC UPS modules)

4.5.1 -48Vdc and Ground/Return Busbar Interconnects

1. Install the provided -48Vdc Interconnect Busbar(s) between the -48Vdc busbars located in each adjacent DC UPS module. Refer to **Figure 19** (DC UPS module with bottom feed DC distribution) and **Figure 20** (DC UPS module with top feed DC distribution). Torque to the values listed in the illustrations.
2. Install the provided Ground/Return Interconnect Busbar(s) between the ground/return busbars located in each adjacent DC UPS module. Refer to **Figure 19** (DC UPS module with bottom feed DC distribution) and **Figure 20** (DC UPS module with top feed DC distribution). Torque to the values listed in the illustrations.

Figure 19 Module-Module Interconnect Busbars (DC UPS Module with Bottom Feed DC Distribution)

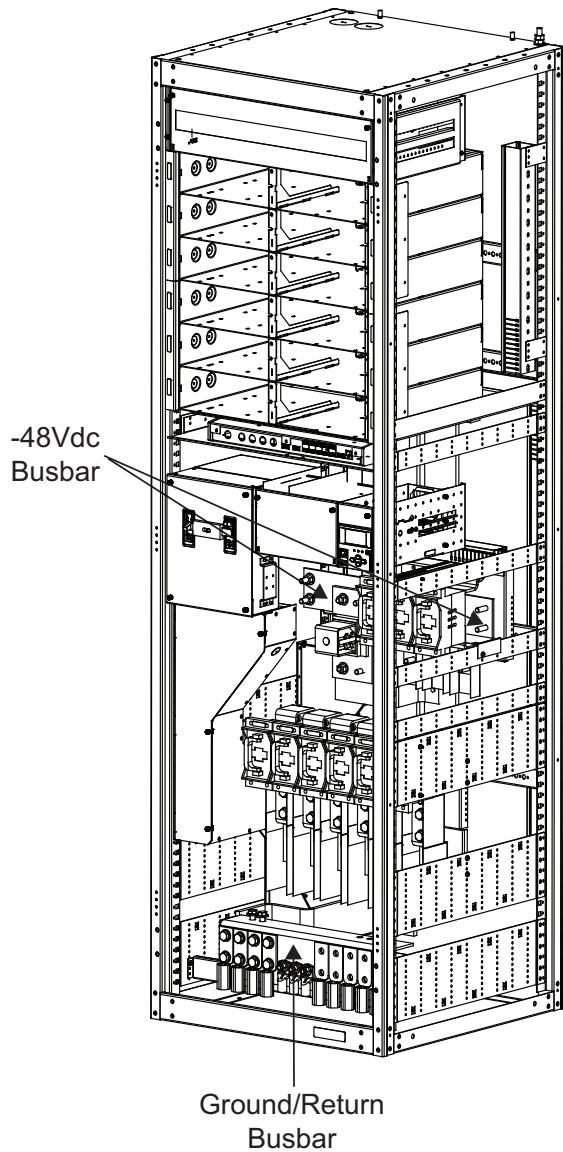

-48Vdc Busbar

Hardware Build-Up

M10 Nut
(electro zinc treatment with bright chromate)

M10 Belleville Lock Washer
DIN 6796-10.5 STEEL
(electro zinc treatment with bright chromate)

Torque to 418 in-lbs (47.3 Nm)



Ground/Return Busbar

Hardware Build-Up

M10 x 30mm Bolt
(electro zinc treatment with bright chromate)

M10 Belleville Lock Washer
DIN 6796-10.5 STEEL
(electro zinc treatment with bright chromate)

Torque to 418 in-lbs (47.3 Nm)

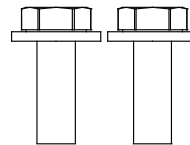

Battery Compartment and Base
Removed in Illustrations for Clarity

-48Vdc Interconnect Busbar
(can be installed on left and/or
right side of module)

Ground/Return Interconnect Busbar
(can be installed on left and/or
right side of module)

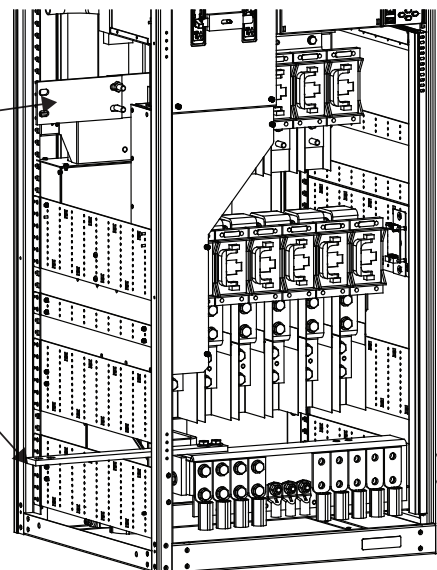
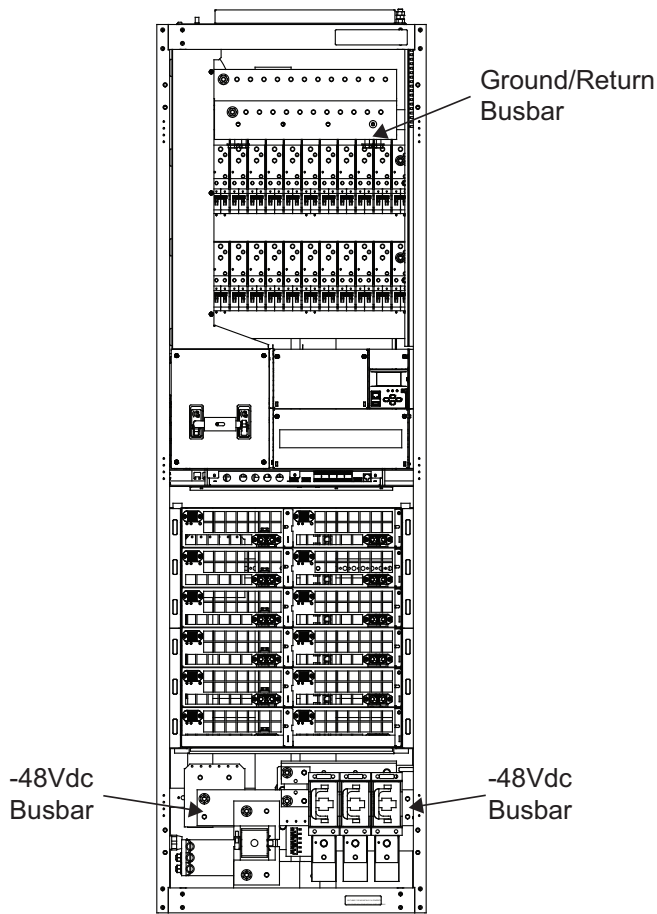

Figure 20 Module-Module Interconnect Busbars (DC UPS Module with Top Feed DC Distribution)



-48Vdc Busbar

Hardware Build-Up

M10 Nut
(electro zinc treatment with bright chromate)

M10 Belleville Lock Washer
DIN 6796-10.5 STEEL
(electro zinc treatment with bright chromate)

Torque to 418 in-lbs (47.3 Nm)



Ground/Return Busbar

Hardware Build-Up

M10 x 30mm Bolt
(electro zinc treatment with bright chromate)

M10 Belleville Lock Washer
DIN 6796-10.5 STEEL
(electro zinc treatment with bright chromate)

Torque to 418 in-lbs (47.3 Nm)

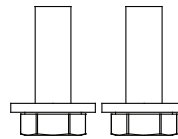

Battery Compartment and Base
Removed in Illustrations for Clarity

Ground/Return Interconnect Busbar
(can be installed on left and/or
right side of module)

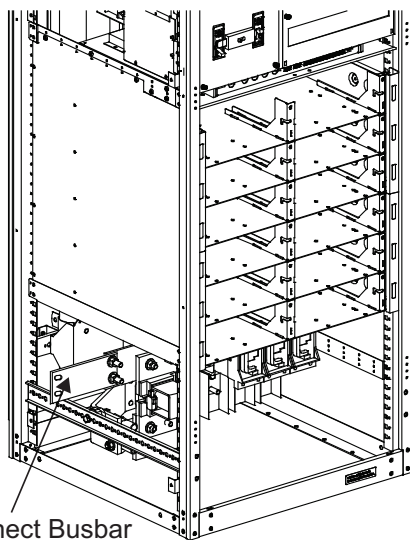

-48Vdc Interconnect Busbar
(can be installed on left and/or
right side of module)

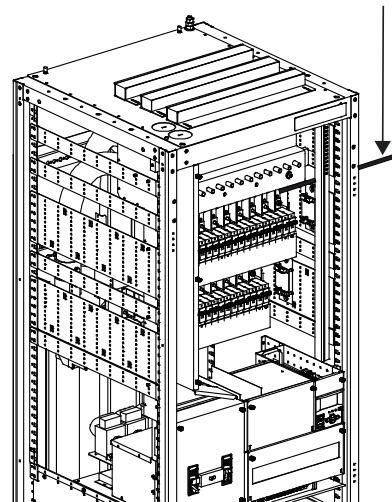

4.6 Making Alarm/Control Interconnections between Modules (if system consists of multiple DC UPS modules)

Make the following module-to-module alarm/control interconnections as required. Refer to **Figure 22** for an interconnect diagram. See also the *Cabinet Interconnections* illustration in **Figure 23**, **Figure 24**, and **Figure 25**.

4.6.1 RS-485 Module-to-Module Interconnect

Primary Module to 1st Expansion Module

1. Locate the long RS-485 interconnect cable (RPM 628 415/2) (yellow/white wire twisted pair) coiled up on the right side of the Primary Module.
2. Route this cable through the openings in the sides of the cabinets to the 1st Expansion Module.
3. Connect this cable to the mating RS-485 interconnect cable connected to the SM-AC located in the 1st Expansion Module (yellow/white wire twisted pair).

1st Expansion Module to 2nd Expansion Module

1. Locate the long RS-485 interconnect cable (RPM 628 415/2) (yellow/white wire twisted pair) coiled up on the right side of the 1st Expansion Module.
2. Route this cable through the openings in the sides of the cabinets to the 2nd Expansion Module.
3. Connect this cable to the mating RS-485 interconnect cable connected to the SM-AC located in the 2nd Expansion Module (yellow/white wire twisted pair).

Additional Expansion Modules

1. Make similar connections between each adjacent Expansion Module.

SM-BRC RS-485 Termination Resistor Setting in Last DC UPS Module

1. A jumper on the SM-BRC circuit board is used for selecting a termination resistor for the RS-485 connection. RS-485 termination is disabled when the jumper is across pins 1 and 2 (default). It is enabled when the jumper is across pins 2 and 3. See **Figure 21** for the location of the jumper.

In most cases, RS-485 termination is not necessary because maximum baud rate is 19200 bps (default is 9600). RS-485 termination is recommended when intermittent communications occur.

If there are intermittent communications errors, it is recommended to set the termination resistor on the SM-BRC in the last module to the enabled position (jumper between pins 2 and 3) instead of the factory disabled position (jumper between pins 1 and 2).

Figure 21 SM-BRC RS-485 Jumper Locations



4.6.2 CAN-Bus Module-to-Module Interconnect

CAN-Bus End Resistor (move only if more than one DC UPS module)

1. Locate the short CAN-Bus interconnect cable jumper connected to the SM-DU+ in the Primary Module (black/white wire twisted pair located behind the SM-DU+ sheetmetal enclosure and

exiting the top of the SM-DU+). Remove the CAN-Bus End Resistor plugged into this cable only if there are Expansion Modules.

2. Locate the short CAN-Bus interconnect cable jumper connected to the SM-DU in the last (end) Expansion Module (black/white wire twisted pair located behind the SM-DU sheetmetal enclosure). Plug the CAN-Bus End Resistor into this cable.

1st Expansion Module to Primary Module

1. Locate the long CAN-Bus interconnect cable (RPM 628 351/1) coiled up on the right side of the 1st Expansion Module (black/white wire twisted pair).
2. Route this cable through the openings in the sides of the cabinets to the Primary Module.
3. Route this cable through the top lip of the Primary Module's SM-DU+ sheetmetal enclosure.
4. Connect this cable to the mating CAN-Bus interconnect cable connected to the SM-DU+ in the Primary Module (black/white wire twisted pair located behind the SM-DU+ sheetmetal enclosure and exiting the top of the SM-DU+).

2nd Expansion Module to 1st Expansion Module

1. Locate the long CAN-Bus interconnect cable (RPM 628 351/1) coiled up on the right side of the 2nd Expansion Module (black/white wire twisted pair).
2. Route this cable through the openings in the sides of the cabinets to the 1st Expansion Module.
3. Connect this cable to the mating CAN-Bus interconnect cable connected to the SM-DU in the 1st Expansion Module (black/white wire twisted pair located behind the SM-DU sheetmetal enclosure).

Additional Expansion Modules

1. Make similar connections between each remaining Expansion Module.

4.6.3 BLVD Module-to-Module Interconnect

1st Expansion Module to Primary Module

1. Locate the BLVD control interconnect cable (RPM 628 466/3) coiled up on the right side of the 1st Expansion Module (the Expansion Module's BLVD cable is factory connected to the bottom connector on the LVD Relay Board, and exits at the back of the LVD Relay Board's sheetmetal enclosure).
2. Route this cable through the openings in the sides of the cabinets to the Primary Module.
3. Route the cable through the back of the Primary Module's LVD Relay Board sheetmetal enclosure.
4. Connect this cable to the mating BLVD control interconnect cable (RPM 628 465/3) in the Primary Module (the Primary Module's BLVD cable is factory connected to the bottom connector located on the LVD Relay Board).

2nd Expansion Module to 1st Expansion Module

1. Locate the BLVD control interconnect cable (RPM 628 466/3) coiled up on the right side of the 2nd Expansion Module (the Expansion Module's BLVD cable is factory connected to the bottom connector on the LVD Relay Board, and exits at the back of the LVD Relay Board's sheetmetal enclosure).
2. Route this cable through the openings in the sides of the cabinets to the 1st Expansion Module.
3. Route the cable through the back of the 1st Expansion Module's LVD Relay Board sheetmetal enclosure.
4. Connect this cable to the mating BLVD control interconnect cable (RPM 628 465/3) in the 1st Expansion Module (the 1st Expansion Module's BLVD cable is factory connected to the bottom connector located on the LVD Relay Board).

Additional Expansion Modules

1. Make similar connections between each remaining Expansion Module.

Figure 22 Alarm/Control Cable Interconnects (cont'd on next page)

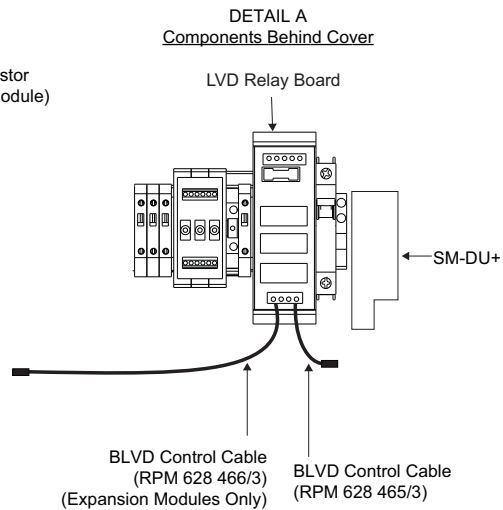
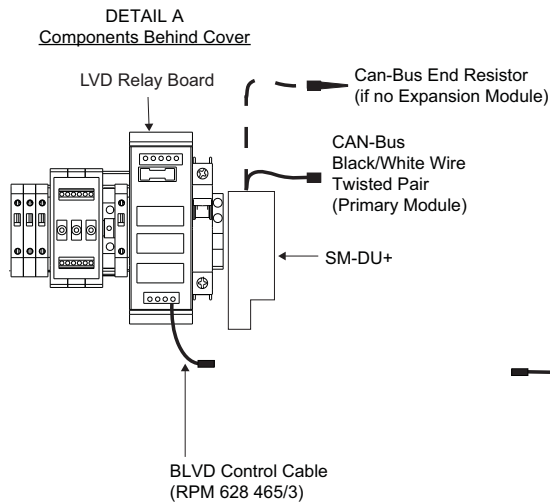
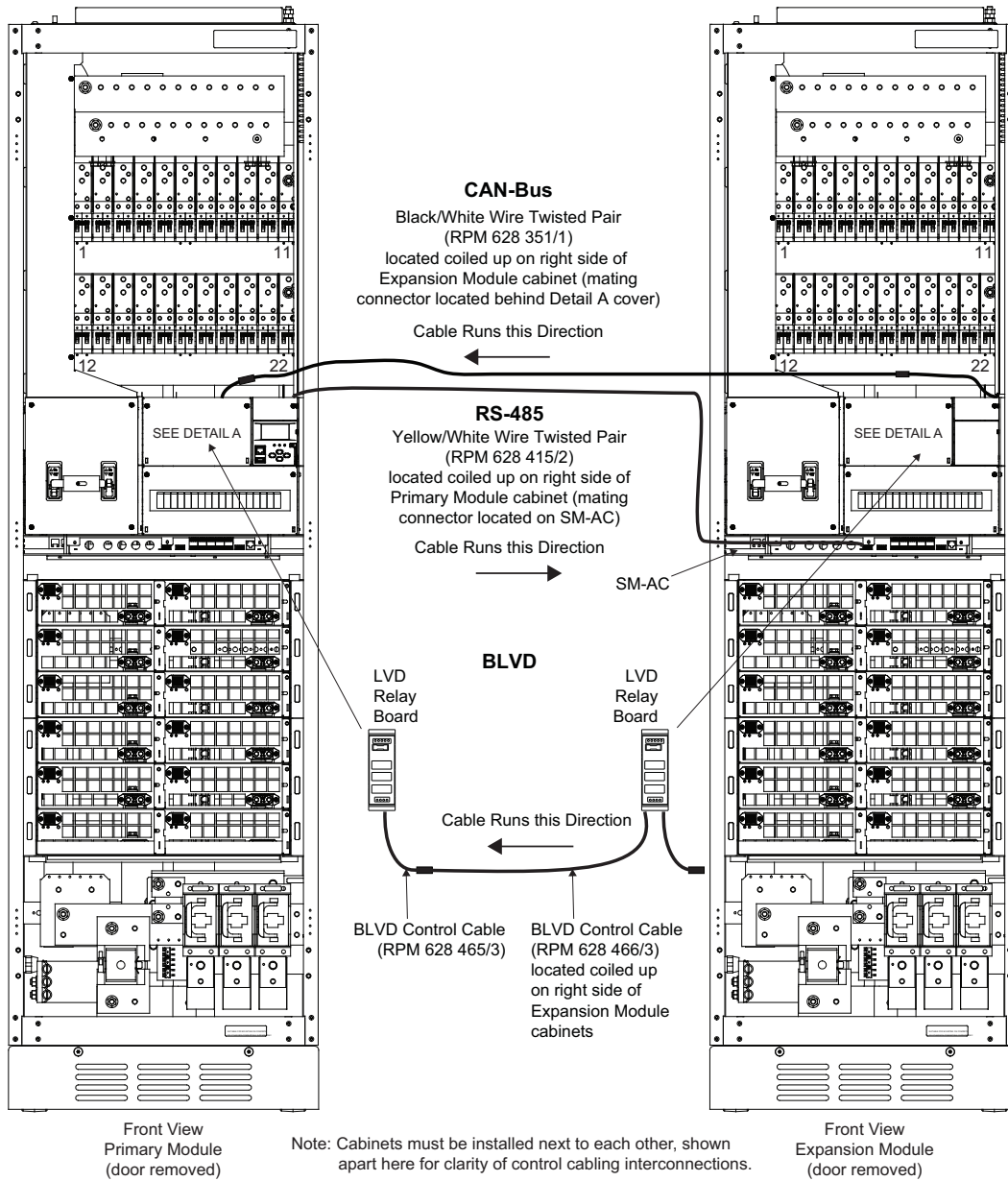

Figure 18 Alarm/Control Cable Interconnects (cont'd from previous page)

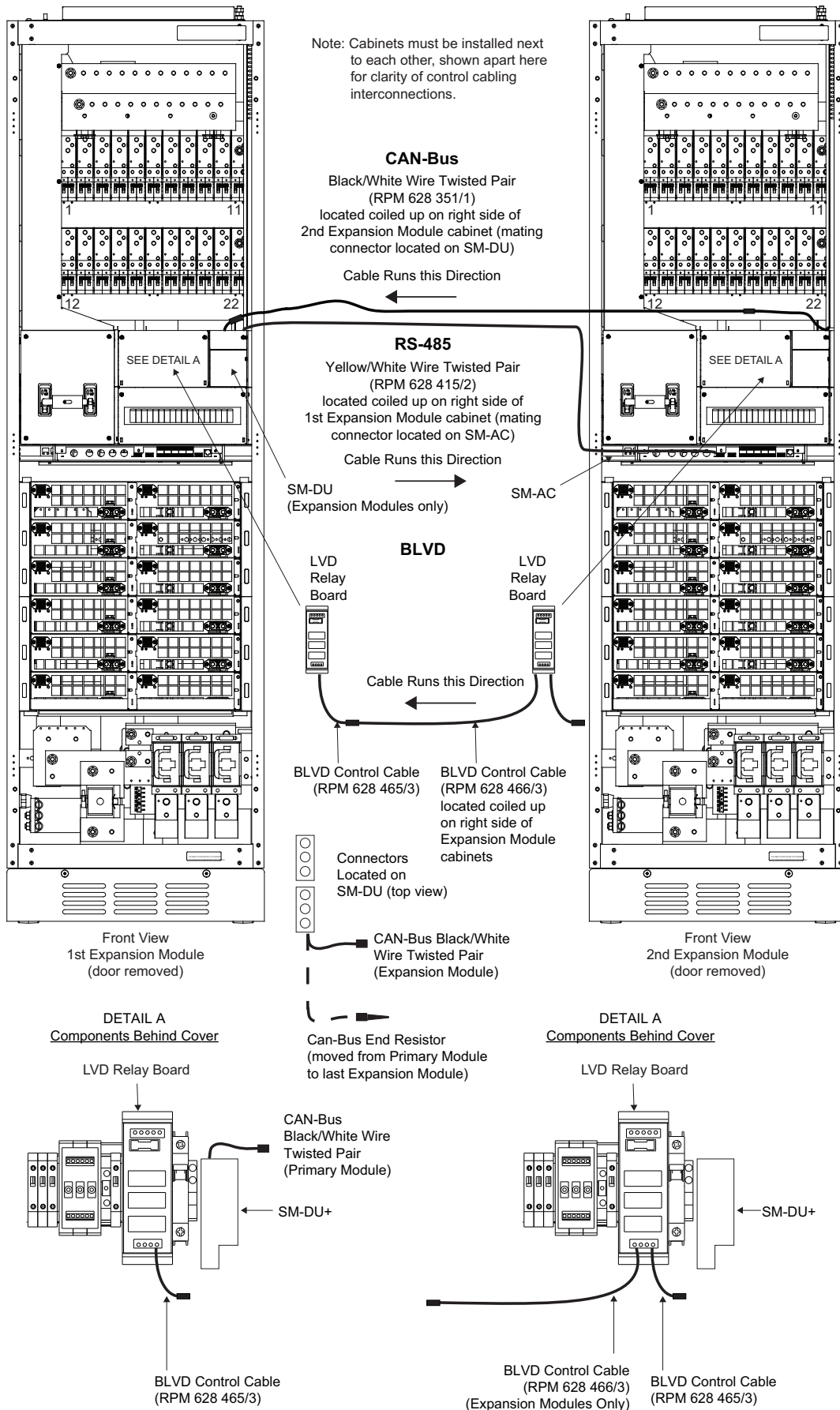
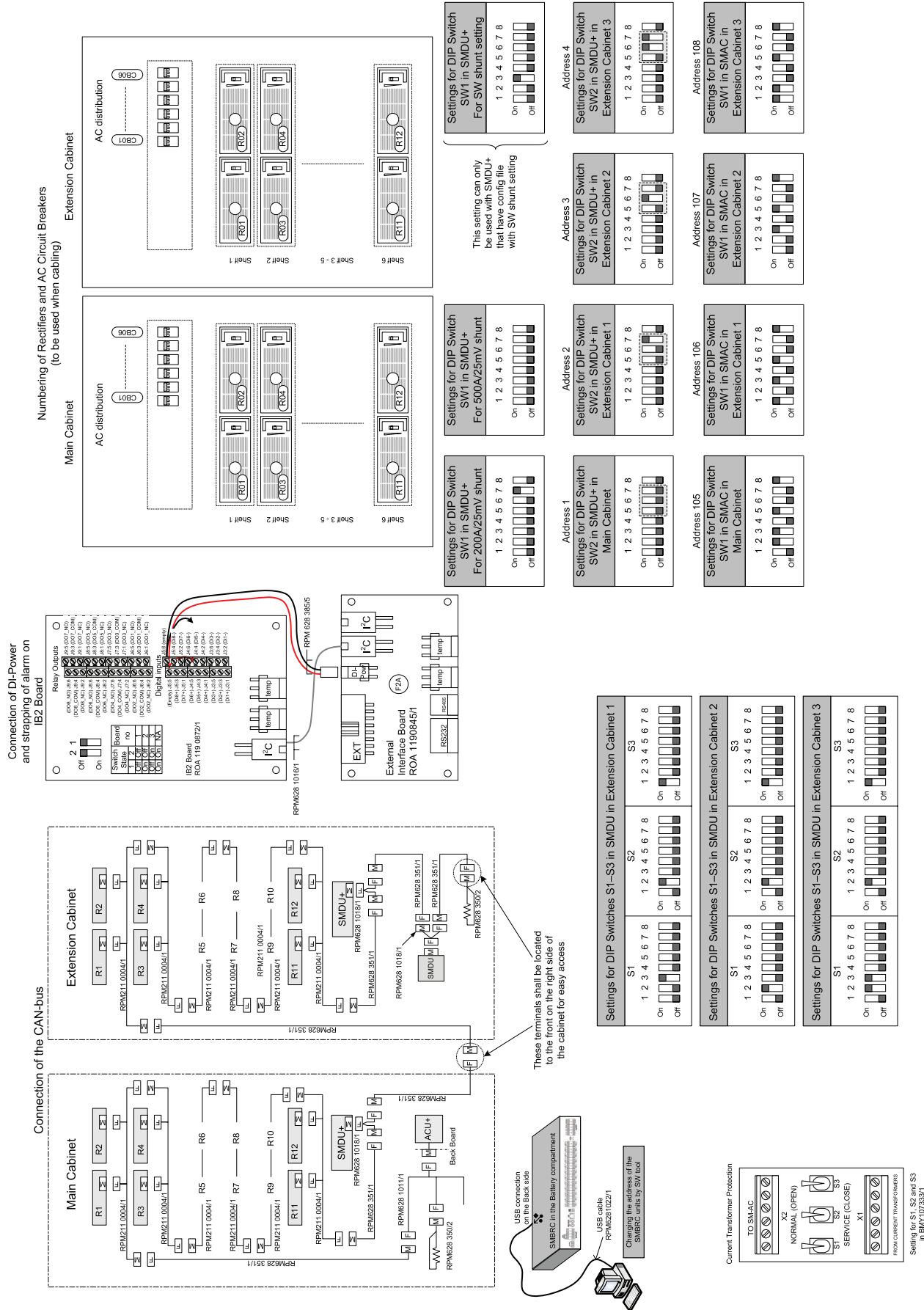

Figure 23 System Configuration and Communications Connections



Figure 25 Signal Cabling and Switch Settings



5.0 INSTALLING PCUs



WARNING

In order to prevent damage to the latching mechanism, do not use excessive force on the PCU handle when pushing the PCU into the cabinet.

PCUs are hot swappable. They can be installed with the system operating.

Procedure

1. Place the PCU into an unoccupied mounting position without sliding it in completely.
2. Push the “Safety Latch Release” located on the front of the PCU "UP". Refer to **Figure 26** for an illustration.
3. Gently push the PCU into the mounting location until it stops.
4. Note that the PCU will NOT be completely seated in the mounting location until the next step is performed.
5. Push the “Safety Latch Release” located on the front of the PCU "DOWN". Gently push the PCU into the mounting location until it is completely seated.
6. Push the PCU's handle in and secure the PCU to the cabinet by tightening the captive fastener located on the handle.
7. Repeat the above steps for each PCU being installed in the DC UPS module.
8. After the PCUs are physically installed, they are ready for operation immediately after power is supplied to them.

Figure 26 PCU Handle and Safety Latch

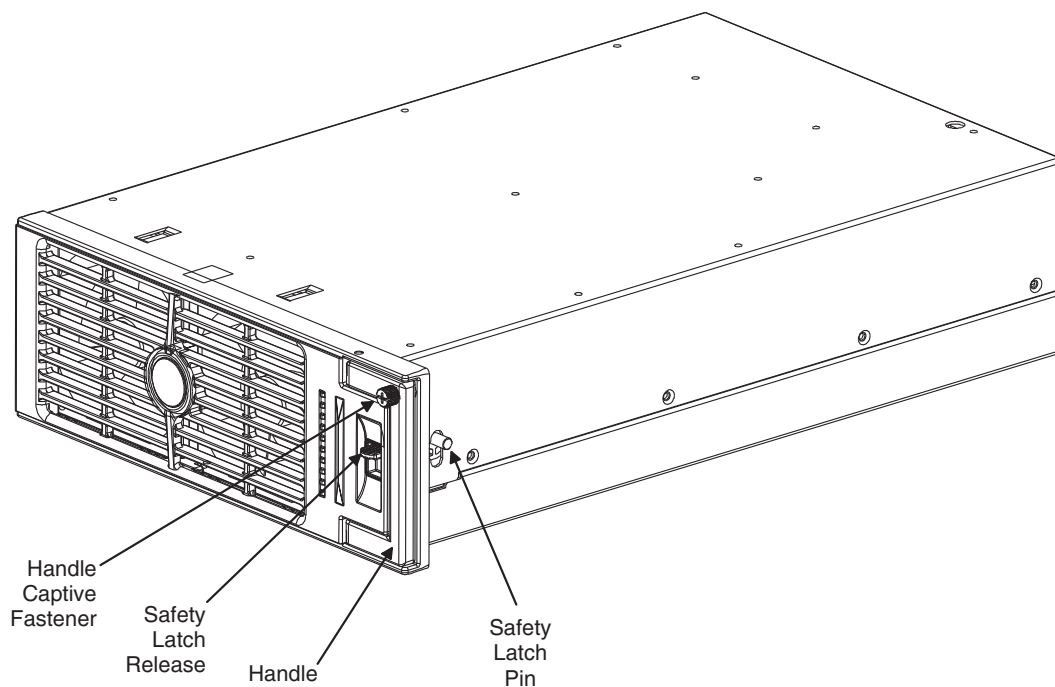

6.0 START-UP INSTRUCTIONS

6.1 General

The NetSure ITM DC UPS system must be fully installed and commissioned before startup. The start-up procedure consists of making final battery connections, initially starting the system, and verifying system operation. Emerson Network Power will perform ALL start-up procedures, including making final battery connections.

The following are general guidelines for Emerson technicians.

6.2 Final Battery Connections

6.2.1 Introduction

Each DC UPS module contains a battery compartment. The battery compartment consists of six battery shelves that house (4) 6V batteries, each. Batteries are factory installed and wired for (3) -48VDC battery strings. Also provided is a 800A battery disconnect fuse for each string.

6.2.2 Safety

Special care should be taken when working with the batteries associated with the DC UPS module. See the precautions in the battery instruction manual and in **Battery Compartment Precautions** at the beginning of these instructions.

6.2.3 Connecting Batteries

Battery Leads

The batteries are factory installed and most battery interconnections are factory made. The following interconnections need to be made during installation to complete the battery electrical path to the DC UPS module. Initial battery torque is 97 in-lbs (11 Nm) for the Emerson EB4 6V200.

1. Refer to **Figure 27** and connect the supplied Battery Interconnect Links between the indicated Battery Shelves. For each connection:
 - a. Install the faston ring lugs on top of the battery links as shown in **Figure 27**.
 - b. Tighten the connections to the torque indicated in **Figure 27**.
 - c. Place the plastic cover over the battery terminals and interconnect link.
2. Refer to **Figure 27** and connect the factory wired battery monitoring leads to the previously installed faston terminals.
3. Check the torque on all remaining battery terminals (factory connections). Torque to value indicated in **Figure 27**.

DO NOT INSTALL THE BATTERY FUSES BEFORE THE EQUIPMENT HAS BEEN COMMISSIONED AND THE PROCEDURE IN "6.3.1 - Initially Starting the DC UPS System and Verifying System Operation" IS PERFORMED.

Figure 27 Making Final Battery Shelf Battery Interconnect Link Connections
DC UPS Module Rear View (Battery Compartment)

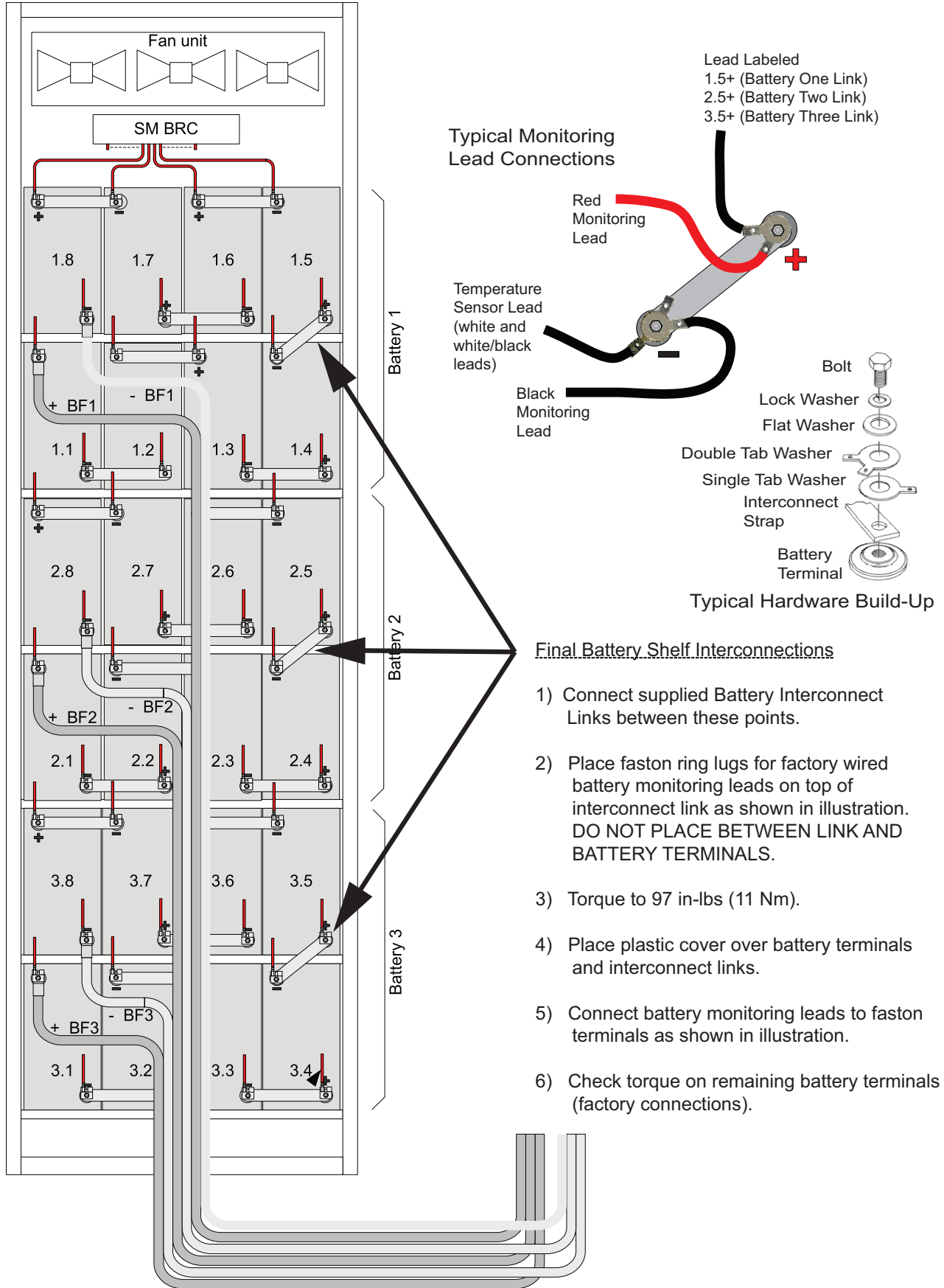

Field Battery Monitoring Lead Connections to the "SiteWeb™ BRC with Alber Technology" Unit

Battery monitoring leads are factory connected to the mating halves of the "SiteWeb™ BRC with Alber Technology" unit's Load Inputs terminal blocks labeled 1, 3, 5, 7 and 2, 4, 6, 8. The DC UPS module is factory shipped with the mating halves of the BRC's Load Inputs terminal blocks labeled 1, 3, 5, 7 and 2, 4, 6, 8 disconnected. This is to prevent the batteries from discharging when the system is not powered.

When the DC UPS module is to be placed into service, open the battery compartment's top rear access panel. Locate the disconnected connectors labeled "Load Inputs 1, 3, 5, 7" and "Load Inputs 2, 4, 6, 8". Plug these connectors into the back of the BRC, as shown in **Figure 28**. Repeat this procedure for each DC UPS module in the system.



NOTE

If the system is powered down for an extended period of time, remove the Battery Fuses and disconnect the BRC's "Load Inputs Terminal Block 1, 3, 5, 7" and "Load Inputs Terminal Block 2, 4, 6, 8" so that the batteries do not discharge.

Figure 28 Field Battery Monitoring Lead Connections to the SiteWeb™ BRC Unit

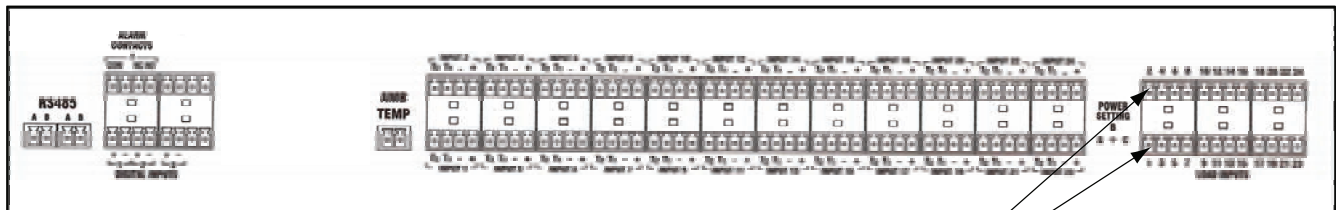
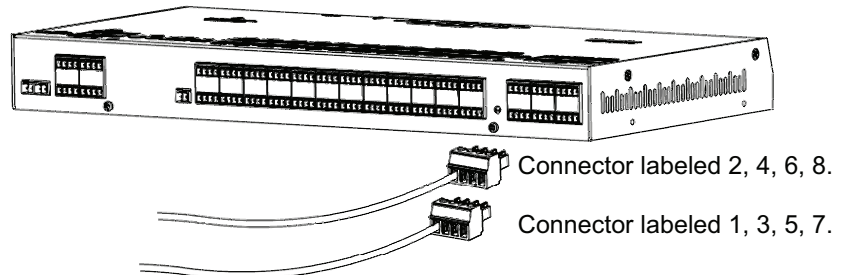

Rear View BRC

Field Battery Monitoring Lead Connections

The DC UPS module is factory shipped with the mating halves of the BRC's Load Inputs terminal blocks 1, 3, 5, 7 and 2, 4, 6, 8 disconnected. When ready to place the module into service, locate and plug the mating halves of the BRC's Load Inputs terminal blocks 1, 3, 5, 7 and 2, 4, 6, 8 here.

6.3 Initially Starting and Verifying DC UPS System Operation



WARNING

During this procedure the output terminals will become live.

If any load equipment is connected to the DC UPS module output terminals, please check with the load user and ascertain whether it is safe to apply power to the load. If the load is not ready to receive power, then ensure that it is safely isolated from the DC UPS module output terminals.

6.3.1 Initially Starting the DC UPS System and Verifying System Operation

Procedure

1. Open the front door on each DC UPS module.
2. Apply AC input power to each DC UPS module by closing the external AC disconnect(s) or protective device(s) that supplies power to each DC UPS module. If the dual AC input feed option is furnished, there will be two (2) devices per DC UPS module.
3. On each DC UPS module, close the main AC input circuit breaker. If the dual AC input feed option is furnished, a safety latch is provided on the circuit breakers to prevent both circuit breakers from being placed in the ON position. Slide the latch over to allow the desired circuit breaker to be turned ON.
4. On each DC UPS module, close all PCU AC input circuit breakers. Note that each circuit breaker feeds two (2) PCUs.
5. In the Primary DC UPS module, once the ACU+ Controller is powered on, a starting... screen appears followed by a language screen.

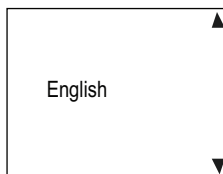

Press “▲” or “▼” to select the desired language. Press **ENT** to confirm the selection. If no key is pressed within 30 seconds, the ACU+ Controller automatically selects the displayed language. Refer to the DC UPS User Manual (Section 6047) for ACU+ Controller local menu operating instructions.

Once initialized, the ACU+ Main Screen displays.

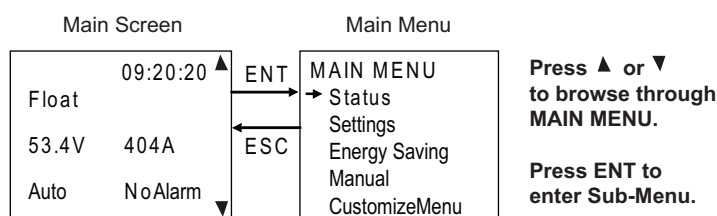

6. With an external meter, measure battery voltage.
7. Adjust the system's float voltage to within approximately 0.5V of battery voltage.
8. In each DC UPS module, install the three battery disconnect fuses.
9. Adjust the system's float voltage to 54.5Vdc.
10. In each DC UPS module, place each distribution circuit breaker to the ON position or install all distribution fuses.
11. In the Primary DC UPS module, verify that there are no alarms present on the ACU+ local display.

7.0 SPECIFICATIONS AND TECHNICAL DATA

7.1 Agency Approvals

The NetSure ITM DC UPS system has the following agency approval ratings:

- EN 60 950-1:2006
- UL 60 950-1
- UL 1801 (This unit is UL Listed ["c UL"] as a DC Power Distribution Center. This unit meets the requirements of CSA 22.2, No. 225 and is tested and Certified by UL ["c UL"] as a Custom Built Power Distribution Center.)

7.2 Environmental

The NetSure ITM DC UPS system is designed to operate under the following environmental conditions without damage or degradation in electrical operating characteristics:

Table 7 DC UPS System Environmental Characteristics

System Operating Temperature	+23 °F to +95 °F (-5 °C to +35 °C) Recommended Operation with Battery (Air Inlet): +68 °F to +77 °F (+20 °C to +25 °C)
System Storage Temperature (optimal)	-4 °F to +77 °F (-20 °C to +25 °C)
Relative Humidity	0 to 95%, non-condensing
Operating Elevation	6562 ft (2000m) at full power
Audible Noise	< 60dB
Heat Rejection at Full Load	18,096 BTU/hr. (5.3kW) per module
EMI	FCC Class A

7.3 Mechanical Characteristics

Table 8 DC UPS System Mechanical Characteristics (per module)

Form Factor	Rack
Unit Dimensions	Inches: 83H x 24W x 41D (Millimeters: 2100H x 600W x 1040D)
Unit Weight	3240 lb (1470 kg)
Airflow	560 CFM (950 m3/h)
Cable Entry	Bottom or Top
Color	Black (Z-0350)
Protection Grade (with open/closed front doors)	IP 20

Table 9 Shipping Dimensions and Weights

System Size	70KW	140KW	210KW	280KW
Module w/ Batteries	(1) Module: <u>Inches:</u> 92H x 29W x 47D <u>Millimeters:</u> 2337H x 737W x 1194D <u>Weight:</u> 3307lb (1500kg)	(2) Modules, per module: <u>Inches:</u> 92H x 29W x 47D <u>Millimeters:</u> 2337H x 737W x 1194D <u>Weight:</u> 3307lb (1500kg)	(3) Modules, per module: <u>Inches:</u> 92H x 29W x 47D <u>Millimeters:</u> 2337H x 737W x 1194D <u>Weight:</u> 3307lb (1500kg)	(4) Modules, per module: <u>Inches:</u> 92H x 29W x 47D <u>Millimeters:</u> 2337H x 737W x 1194D <u>Weight:</u> 3307lb (1500kg)
PCUs	12 PCUs: <u>Pallet (12 PCUs):</u> <u>Inches:</u> 22H x 44W x 48D <u>Millimeters:</u> 559H x 1118W x 1219D <u>Weight:</u> 258lb (117kg)	24 PCUs: <u>Pallet (24 PCUs):</u> <u>Inches:</u> 38H x 44W x 48D <u>Millimeters:</u> 965H x 1118W x 1219D <u>Weight:</u> 486lb (220kg)	36 PCUs: <u>1st Pallet (30 PCUs):</u> <u>Inches:</u> 46H x 44W x 48D <u>Millimeters:</u> 1168H x 1118W x 1219D <u>Weight:</u> 600lb (272kg) <u>2nd Pallet (6 PCUs):</u> <u>Inches:</u> 14H x 44W x 48D <u>Millimeters:</u> 356H x 1118W x 1219D <u>Weight:</u> 144lb (65kg)	48 PCUs: <u>1st Pallet (30 PCUs):</u> <u>Inches:</u> 46H x 44W x 48D <u>Millimeters:</u> 1168H x 1118W x 1219D <u>Weight:</u> 600lb (272kg) <u>2nd Pallet (18 PCUs):</u> <u>Inches:</u> 30H x 44W x 48D <u>Millimeters:</u> 762H x 1118W x 1219D <u>Weight:</u> 372lb (169kg)

7.4 Monitoring Capability

Standard: Web-based monitoring, alarm reporting via SNMP, and integration with SiteScan via SiteLink-E module.

Optional: Energy Master Remote Supervision.

7.5 Electrical Characteristics

7.5.1 Termination Type, Recommended Wire Size, Recommended Lugs

AC Input

Table 10 AC Input and AC Input Grounding (per DC UPS module)

AC Input				
Input Voltage	Maximum Input Current	Terminal Type	Recm. Wire Size ¹	Conduit Size
480Vac	92A	Screw Clamp	2/0 AWG	2"
400Vac	110A			
380Vac	116A			
AC Input Grounding				
Input Voltage	Bolt Size	Recm. Wire Size ¹	Conduit Size	Recommended Lug (Thomas & Betts P/N)
				Compression 1-Hole; 3/8" Bolt
480Vac	5/16" (M8)	1/0 AWG	2"	54109
400Vac				

¹ Wire sizes based on recommendations of the American National Standards Institute (ANSI) approved National Fire Protection Association's (NFPA) National Electrical Code (NEC). Table 310-16 for copper wire at 90°C conductor temperature operating in ambient of 35°C was used. For other operating ambient temperatures, refer to the NEC. For operation in countries where the NEC is not recognized, follow applicable codes.

Equipment grounding conductors must be provided with the AC input conductors supplied to the module. Frame ground terminals must be connected to earth ground, not power system neutral.

Equipment grounding conductor size based on recommendations of the NEC Table 250-122 for copper wire. When aluminum or copper clad aluminum grounding conductor is used, refer to Table 250 122 for increased conductor size. For operation in countries where the NEC is not recognized, follow applicable codes.

Cabinet Frame Grounding

Table 11 Cabinet Frame Grounding (per DC UPS module)

Bolt Size	Recm. Wire Size	Recommended Lug (Thomas & Betts P/N)
		Compression 1-Hole; 3/8" Bolt
3/8" (M10)	6 AWG	54136

DC Distribution

Table 12 DC Distribution (Distribution Circuit Breaker Option - per circuit breaker position)

OCP Device Rating	Maximum Output Current @ 54V	Terminal	Bolt Size	Recm. Wire Size ¹	Lug Requirement	Recommended Lug (Thomas & Betts P/N)
100A	80A	Load	3/8" (M10)	1/0 AWG	2-Hole, 1" Centers	54209
		Return			1-Hole	54109
150A	120A	Load		1/0 AWG	2-Hole, 1" Centers	54209
		Return			1-Hole	54109
175A	140A	Load		2/0 AWG	2-Hole, 1" Centers	54210
		Return			1-Hole	54110
200A	160A	Load		3/0 AWG	2-Hole, 1" Centers	54211
		Return			1-Hole	54111

¹ Wire sizes based on recommendations of the American National Standards Institute (ANSI) approved National Fire Protection Association's (NFPA) National Electrical Code (NEC). Table 310-16 for copper wire at 75°C conductor temperature operating in ambient of 35°C was used. For other operating ambient temperatures, refer to the NEC. For operation in countries where the NEC is not recognized, follow applicable codes. Sizes assume one layer of cables in open cable tray. Alternate sizing may be required for other installation configurations. Refer to the NEC or contact Emerson Services (contact information provided at the end of this document).

Table 13 DC Distribution (Distribution Fuse Option - per fuse position)

OCP Device Rating	Maximum Output Current @ 54V	Terminal	Bolt Size	Recm. Wire Size ¹	Lug Requirement	Recommended Lug (Thomas & Betts P/N)
200	160	Load	1/2" (M12)	3/0 AWG	2-Hole, 1.75" Centers	54265
		Return				
500	400	Load		(2) 250 kcmil		
		Return				(2) 54275

¹ Wire sizes based on recommendations of the American National Standards Institute (ANSI) approved National Fire Protection Association's (NFPA) National Electrical Code (NEC). Table 310-16 for copper wire at 75°C conductor temperature operating in ambient of 35°C was used. For other operating ambient temperatures, refer to the NEC. For operation in countries where the NEC is not recognized, follow applicable codes. Sizes assume one layer of cables in open cable tray. Alternate sizing may be required for other installation configurations. Refer to the NEC or contact Emerson Services (contact information provided at the end of this document).

Battery

The battery cables are factory provided and sized accordingly.

Alarm/Control

Table 14 Alarm/Control

Screw Size	Recm. Wire Size
M2	24-16 AWG

7.5.2 Power Ratings

Table 15 Power Ratings

Power Rating	Primary Module 1	Expansion Module 2	Expansion Module 3	Expansion Module 4
Full	70 kW	70 kW	70 kW	70 kW
N + 1	64 kW	70 kW	70 kW	70 kW

7.5.3 AC Input Specifications

Table 16 AC Input Specifications

Phase	3
Power Factor	0.99 at full load, 0.98 at 50% load
Frequency	45-65 Hz
Input Voltage – Nominal	400 / 480V, 3 wire + ground
Input Voltage – Range	304-530 VAC; shall withstand up to 600 VAC input without damage.
Internal AC Input Breaker Size	150A
Internal AC Input Breaker AIC Rating	65,000A
Max Input Current / Module	Nominal 480V: 115A @ 384V; 92A @ 480V Nominal 400V: 138A @ 320V; 110A @ 400V Nominal 380V: 145A @ 304V; 116A @ 380V
Inrush Current	Inrush current does not exceed 150% of the rated input steady state peak value.
Total Harmonic Distortion	<5% from 50-100% of load

7.5.4 DC Output Specifications

Table 17 DC Output Specifications

Voltage	Normal Operation: -54.5 VDC (battery float) Nominal: -48VDC Range: -42 to -58 VDC
System Efficiency	92.5% peak (system level including branch distribution losses)
Energy Optimization Mode; Intelligent Power Matching	Allows operation at near-peak efficiency down to 5% overall load.
Distribution Types	22 Circuit Breakers, 100-200A each; Optional: 6 Fuses, 100-500A each

7.5.5 Battery Specifications

Table 18 Battery Specifications

Type	VRLA, Emerson Excellence EB4, 200 Ah
Arrangement	3 strings; eight 6V blocks per string
Backup Time	See backup time table at various loads.
Design Life	15 years @ 20°C; 10 years @ 25°C
Recharge Time (to 97% of nominal capacity)	Less than 3 hours for > 35% load; Less than 4 hours > 15% load.
MECHANICAL	
<u>Dimensions</u>	
Depth:	377 mm, including connectors and covers
Width:	135 mm, including ventilation spacing
Height:	250 mm
Weight:	37 kg
CAPACITY	
<u>Constant Power Discharge @ 20°C (w/cell):</u>	
<u>End Voltage</u>	<u>Operating Time To End Voltage (minutes)</u>
Per Cell	600 480 360 300 240 180 120 60
<u>Constant Current Discharge @ 20°C (A):</u>	
<u>End Voltage</u>	<u>Operating Time To End Voltage (minutes)</u>
Per Cell	600 480 360 300 240 180 120 60
OTHER TECHNICAL FEATURES	
	<ul style="list-style-type: none"> • Valve-regulated lead-acid battery with AGM technology. • Validation in accordance with IEC 896-2.

Battery Back-up Time (minutes)				
Load	Single module 70kW	Two modules 140kW	Three modules 210kW	Four modules 280kW
10kW	130	300	480	630
20kW	55	130	210	300
30kW	28	90	130	180
40kW	17	55	90	130
50kW	12	41	70	100
64kW	7	24	50	75
70kW	3	21	43	69
80kW		17	34	55
90kW		14	27	47
100kW		12	22	40
110kW		10	19	34
120kW		8	17	28
134kW		6	16	25
140kW		3	14	22
150kW			12	19
160kW			10	17
170kW			9	15
180kW			8	14
190kW			7	13
204kW			4	11
210kW			2	10
220kW				9
230kW				9
240kW				8
250kW				7
260kW				6
274kW				3
280kW				1

8.0 REVISION RECORD

Issue	Change Number (ECO)	Description of Change
08	--	Pre-Release

NetPerform™ Optimization Services

At Emerson Network Power, we understand the importance of reliable equipment – it's critical to both your business and your bottom line. That is why we offer a wide array of services to meet all of your network infrastructure needs.

Technical Support

Email	DCpower.TAC@Emerson.com OSP.TAC@Emerson.com	Answers technical product and system questions; determines status of warranties and contractual agreements for repair.
Phone	1.800.800.5260	

Services - Design, Deployment & Optimization

Email	ES.Services@Emerson.com	Provides quotes and bid responses, order placement and scheduling for design, and deployment and optimization services.
Phone	1.800.800.1280, option 7	
FreedomCare	Secure.EmersonNetworkPower.com	Download service & maintenance reports online.

Spare Parts

Email	DCpower.Spares@Emerson.com OSP.Spares@Emerson.com	Pricing and PO processing of spare parts, including but not limited to breakers, cables, fuses, rectifier fans, misc. breaker and fuse panels, enclosure fans, doors & switches, etc.
Phone	1.800.800.1280, option 5	

DC Power Depot Repair

Email	DCpower.Repair@Emerson.com	Creates and processes RMAs, determines lead times and pricing, provides repair shipping information and status.
Phone	1.800.800.1280, option 6	

DC Power Product Training

Email	DCpower.Training@Emerson.com	Requests for quotes, order placement and scheduling.
Phone	1.800.800.1280, option 8	

For More Information

To learn more about service offerings from Emerson Network Power, please contact your sales representative, call 1-800-800-1280 option 7, email ES.Services@Emerson.com or visit www.EmersonNetworkPower.com/EnergySystems.

Emerson (NYSE: EMR), based in St. Louis, is a global leader in bringing technology and engineering together to provide innovative solutions for customers in industrial, commercial, and consumer markets through its network power, process management, industrial automation, climate technologies, and appliance and tools businesses. For more information, visit: Emerson.com.

Emerson Network Power, a business of Emerson (NYSE:EMR), is the global leader in enabling *Business-Critical Continuity*™ from grid to chip for telecommunication networks, data centers, health care and industrial facilities. Emerson Network Power provides innovative solutions and expertise in areas including AC and DC power, precision cooling, embedded computing and power, integrated racks and enclosures, power switching and controls, infrastructure management, and connectivity. All solutions are supported globally by local Emerson Network Power service technicians. For more information on Emerson Network Power's full suite of solutions specifically supporting the communications network infrastructure, visit: EmersonNetworkPower.com/EnergySystems.

Learn more about the NetSure™ ITM DC UPS from Emerson at: EmersonNetworkPower.com/NetSureITM.

Emerson Network Power

Energy Systems, North America

4350 Weaver Parkway, Warrenville, IL 60555

Toll Free: 800-800-1280 (USA and Canada)

Telephone: 440-246-6999 **Fax:** 440-246-4876

Web: EmersonNetworkPower.com/EnergySystems

EnergyNet: Secure.EmersonNetworkPower.com

Emerson Network Power.

The global leader in enabling *Business-Critical Continuity*™.

- | | | | |
|-------------------|--|------------------------------|-------------------------------|
| ■ AC Power | ■ Embedded Computing | ■ Outside Plant | ■ Racks & Integrated Cabinets |
| ■ Connectivity | ■ Embedded Power | ■ Power Switching & Controls | ■ Services |
| ■ DC Power | ■ Infrastructure Management & Monitoring | ■ Precision Cooling | ■ Surge Protection |

EmersonNetworkPower.com