

Liebert Npower™ 30 to 130 kVA
Innovative UPS Technology for Maximum Power Quality

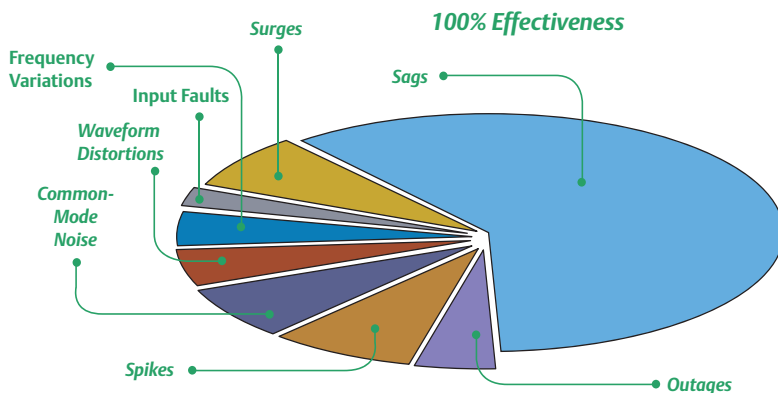

We've re-invented the double-conversion UPS

Today's business processes cannot be interrupted. Businesses are buying and selling around the world, around the clock, every day. Even 40-hours-per-week operations need the reliability and maintainability of true 24x7 infrastructure during those 40 hours. That's why the cornerstone of your infrastructure should be the most reliable and advanced 3-phase UPS in its power range: the Liebert Npower.



Output Waveform, 0-100% Step Load

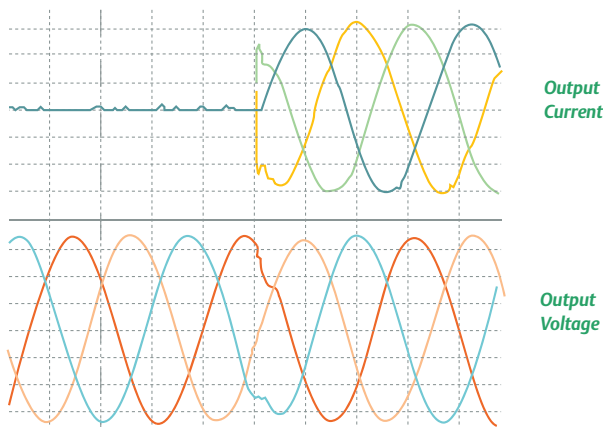

Reliability Comes First

Reliability is a Liebert family tradition. All Liebert three-phase UPS products use double-conversion technology and all have field-proven critical bus Mean Time Before Failure (MTBF) in excess of one million hours.

Double Conversion for 100% Protection

The UPS must support your business processes by providing clean, reliable uninterrupted power. A true double-conversion UPS is the only way to guard against the full spectrum of power disturbances. Anything less is a compromise.

Single-conversion UPS products (off-line, line-interactive and some self-proclaimed "online" topologies) cannot provide complete protection. Common-mode noise and frequency variations will pass straight through to the critical load. In addition, single-conversion products are vulnerable to input faults.

ActiveStar™ Controls for World-Class Performance

The Liebert Npower has truly spectacular operating performance, unmatched by any UPS in the industry. The all-digital ActiveStar controls are DSP-based and feature unique, patent-pending technology. The Npower makes fast adjustments to changing loads, including subcycle pulse-width corrections to keep the output voltage waveform nearly flawless.

Output voltage distortion (THD) typically measures less than 2.5%, under worst-case high-crest-factor, non-linear loads. The Npower is rugged enough to handle load branch faults, input faults, 100% step loads, PDU startup inrush and motor-load startup.

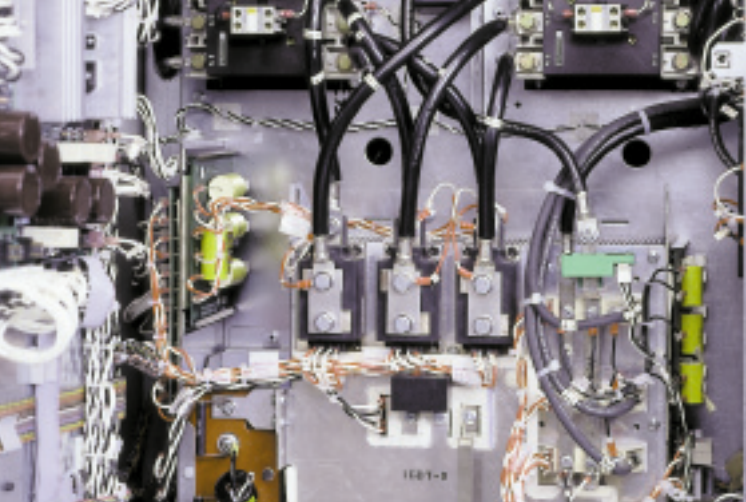

Exceptional Overload Performance

The combination of rugged inverter and continuous-rated static switch gives the Liebert Npower exceptional overload capability. By itself, the Npower inverter can supply up to 200% of rated capacity for 10 cycles and 150% for a full minute while maintaining a true sinusoidal waveform to the load. It can also handle up to 125% of rated capacity for ten minutes. Even during bolted faults, the ActiveStar controls are able to limit inverter output current to safe levels.

The internal static switch has two operating modes. For faults or transformer inrush currents, the static switch operates in the pulsed-parallel mode: the inverter remains connected while the static switch supplements inverter current with power from the bypass source. If the load continues to exceed the overload rating of the inverter, the static switch operates in the continuous-duty mode.

When Npower is used in the 1+1 Redundant configuration, the full overload capacity of both modules is available to source fault current or handle momentary overloads. The inverters and static bypass switches work in parallel to support the critical load. Total power available will be limited by the rating and settings of the system output breaker in the Paralleling Cabinet. This breaker is typically set for the output rating of a single Npower module.

Overload capability of Liebert Npower UPS as a percent of nominal rating

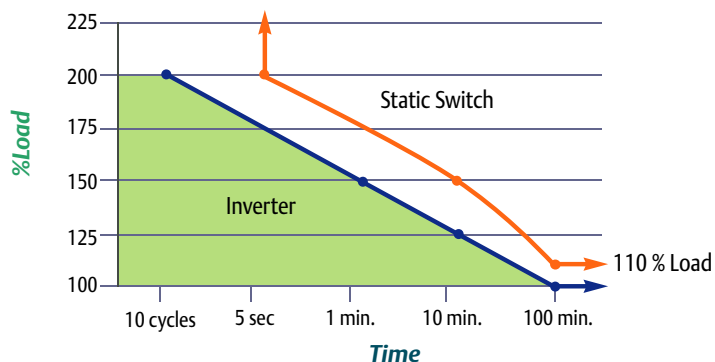

Rating of the internal static switch in amps

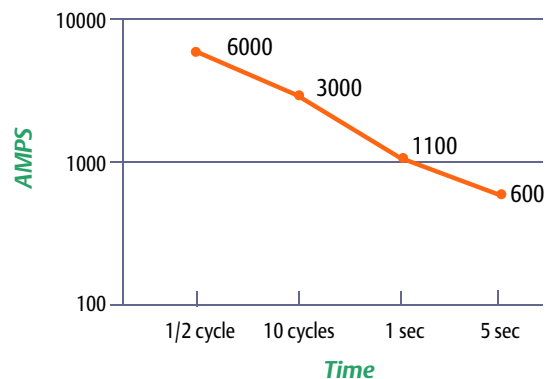

The overload curves above tell a remarkable story. The upper curve represents inverter capability as a function of overload versus time. The inverter remains on-line providing regulated power output at full voltage at every point of the overload/time curve. The lower curve represents the capabilities of the internal static switch. If the load moves beyond the line representing inverter capacity, the static switch will support the load to the full extent of its capacity.

The static switch has truly exceptional fault-clearing capacity, as shown in the second chart above. All Liebert Npower models have static switches rated for 6000 amps for the first half cycle, 3000 amps for 10 cycles, 1100 amps for one second and 600 amps for 5 seconds.

ActiveStar™ Controls for World-Class Performance

ActiveStar is a DSP-based control system that makes the UPS behave like a model citizen. ActiveStar controls the entire power train, including the Rectifier, DC Bus, Inverter and Static Switch. This makes the Liebert Npower very aware of its environment, and able to make intelligent adjustments.

Rectifier and DC Bus

The rectifier has an unusually large window of usable input voltage. Liebert Npower is able to operate at full load without discharging the batteries even when input voltage drops 20% below nominal. The feed-forward frequency control of the rectifier allows it to track the output of an unstable generator.

When the rectifier senses a large load step, it makes sub-cycle corrections to its phase angle and immediately begins drawing more power into the DC bus. This minimizes the effect of short-duration "hits" on the battery string and extends battery life.

At lower load levels, ActiveStar disconnects the input filter capacitors, to keep from presenting a leading power factor to the utility or to the standby genset. As the load increases, ActiveStar reconnects the capacitors, to optimize the input power factor and minimize harmonic currents reflected back to the input source.

Npower takes very good care of its batteries, with temperature compensated charging and other important features. As mentioned earlier, the rectifier responds quickly to load steps, reducing the

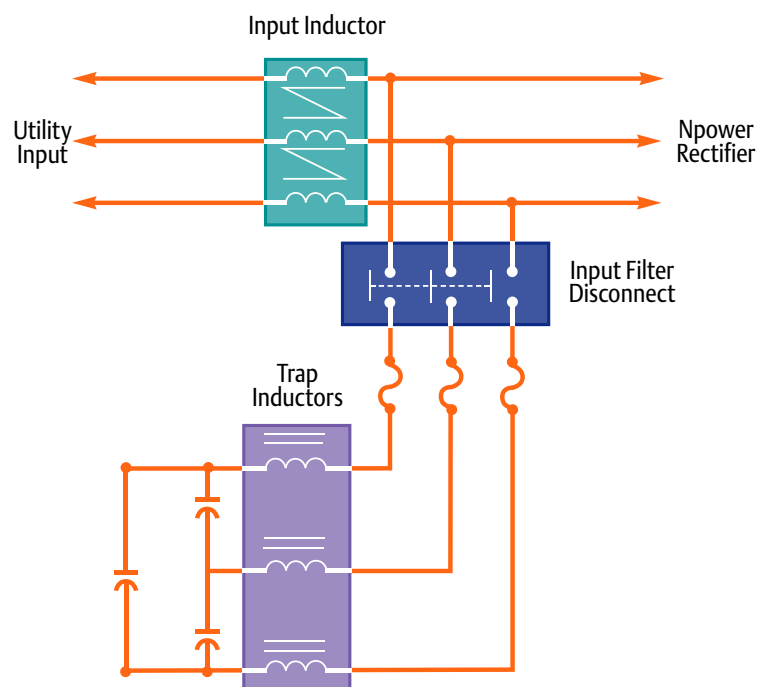

number of short-duration battery "hits," which can greatly reduce battery life expectancy. In addition, the Npower can schedule regular battery self-test procedures, to verify that the battery string is capable of supporting the connected load.

The internal battery cycle monitor records the duration, kW and battery end voltage for every battery discharge event. This enables you to evaluate battery

performance and see how hard your batteries are working in this application.

The ActiveStar controls also optimize battery performance during longer discharge periods. During longer battery discharge events, the Npower gradually increases the low-battery shutdown voltage. This prevents the batteries from being discharged too deeply, and incrementally improves battery service life.

ActiveStar Inverter Elements

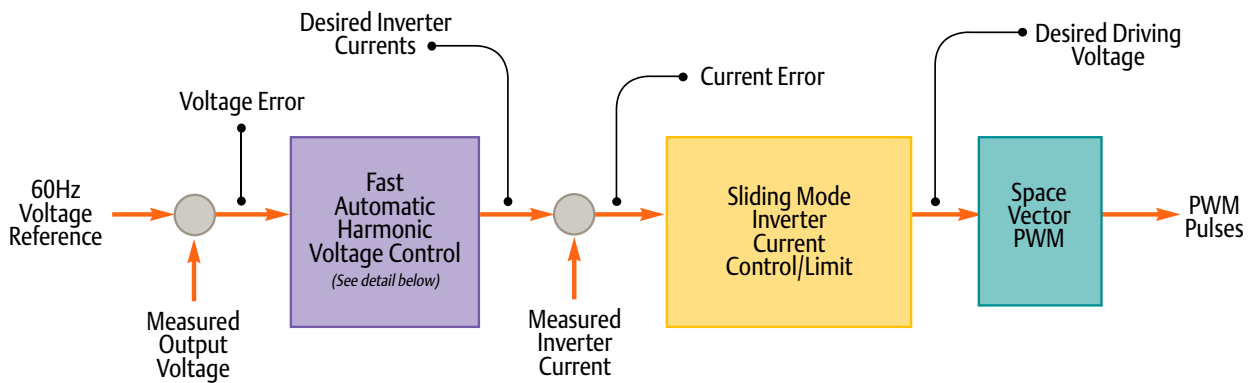

Inverter

The ActiveStar inverter controls have three elements, Voltage Harmonic Control, Sliding Mode Inverter Current Control, and Space-Vector PWM Inverter.

Voltage Harmonic Control compares the actual UPS output voltage to a 60Hz reference signal. It senses the content of load-generated harmonics and components introduced by unbalanced loads, and computes the compensating signals necessary to eliminate them. The Stabilizer then computes the amount of current necessary to force the voltage error to zero and ensure system stability.

The Sliding-Mode Current Control takes the output from the Stabilizer and determines the driving voltage necessary to make inverter currents follow what the voltage control desires. The Current Control corrects errors between desired and actual current in a single PWM pulse. On a bolted fault, this allows the inverter to limit its current at a safe level, rather than requiring immediate shutdown when bypass is not available. ActiveStar compensates once per PWM pulse (50 times per line cycle) compared to older UPS technology, which limits currents by gradually reducing its 60 Hz voltage reference once per line cycle (1/60 sec.).

Details of Fast Automatic Harmonic Voltage Control

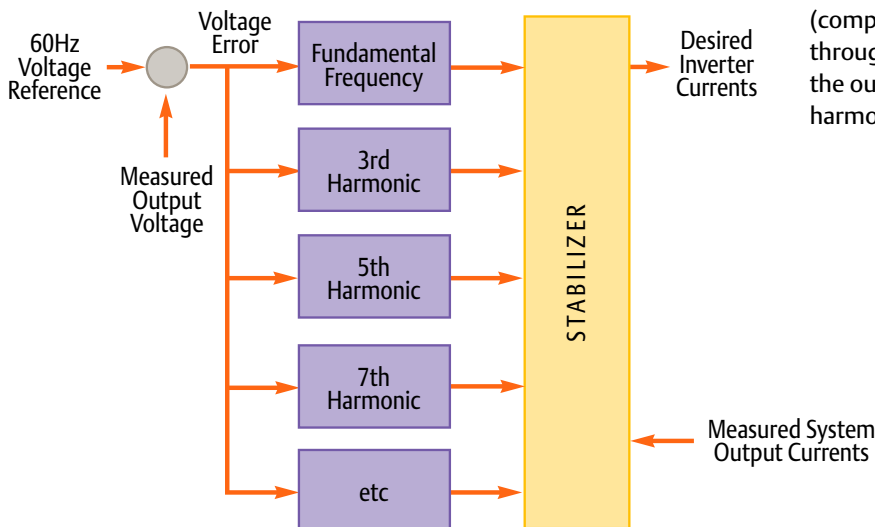

ActiveStar constantly monitors the harmonics being reflected by the customer's load equipment, and cancels them electronically. The inverter sources (compensates for) the harmonics as it sends pulses through the output isolation transformer. As a result, the output transformer never directly experiences the harmonics, and runs cooler and quieter.

Liebert Npower: The Best Value in a Mid-Range UPS

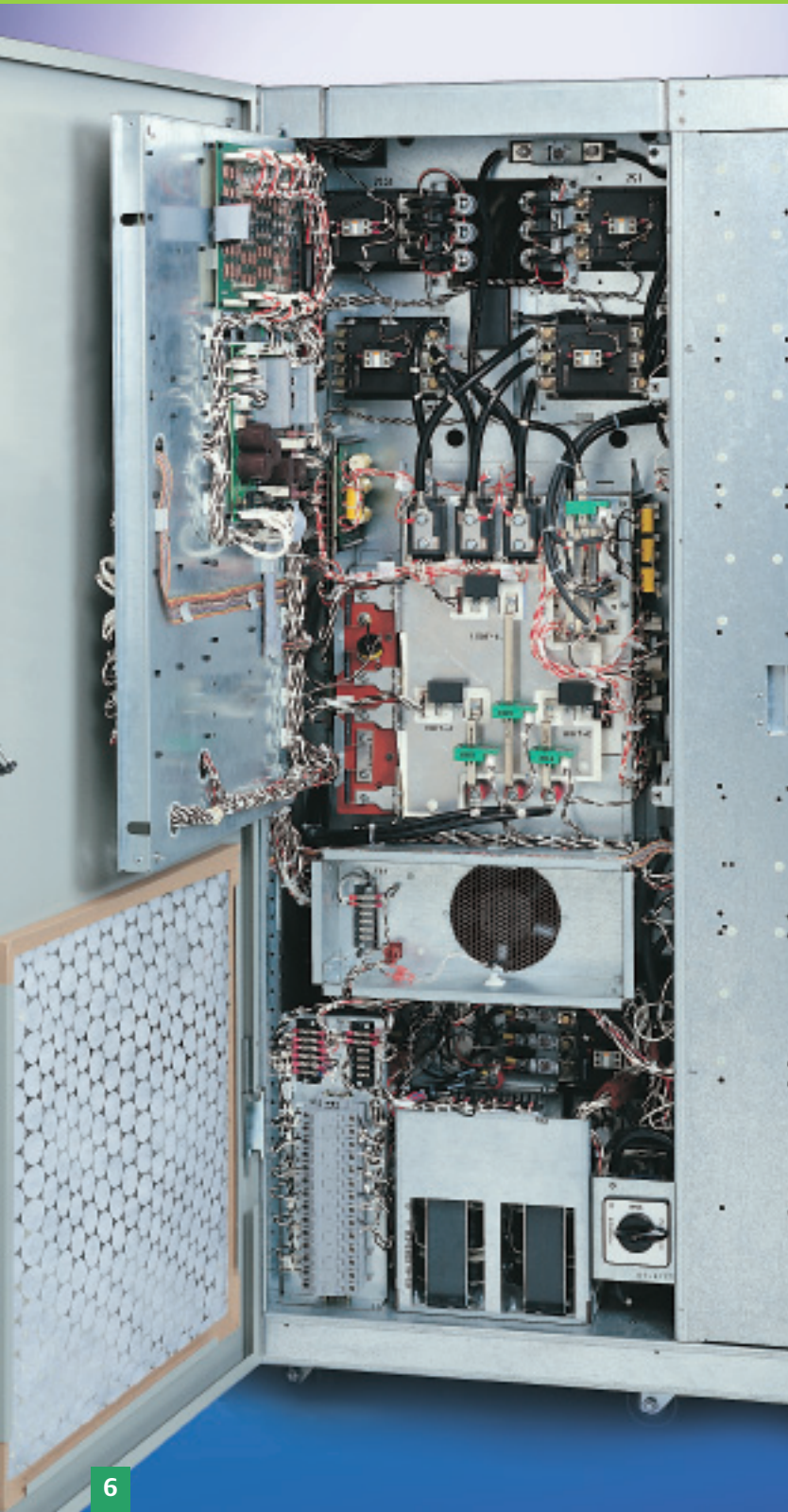

The Liebert Npower gives you more UPS for about the same initial cost as lesser products. Furthermore, the Npower will usually cost significantly less over the lifetime of the product. The value comes from several elements: exceptional protection, higher efficiency, lower installation, maintenance and operating costs, smaller total system footprint and more standard features.

Higher Efficiency in Real-World Applications

Critical applications require a UPS to have an input filter (to reduce input current distortion) and an output isolation transformer (to isolate your critical load), while powering non-linear (high-crest-factor) loads at less than the rated capacity of the UPS.

The fully equipped Liebert Npower has excellent efficiency – typically between 92% and 93.5% – while powering high-crest-factor loads between 50 and 100% of its rated capacity. Furthermore, the input power factor is exceptionally high, typically 0.95 to 0.96 for models with 480 VAC input.

In this power range (up to 130 kVA), the only way to exceed 93.5% efficiency is to leave out something important. Some competitors omit the output isolation transformer; others put your critical load at risk with their single-conversion UPS products. Only you can decide if the claimed savings justify the risk.

High-Availability Configurations

The Liebert Npower UPS can be used reliably as a single module and in various redundant configurations. The Npower 1+1 Redundant option, described on pages 10-11 of this brochure, is a cost-effective parallel-redundant system. Parallel redundancy improves maintainability and fault tolerance, thereby enhancing system availability.

For the ultimate in high-availability systems, Npower can be applied in various distributed-redundant (dual-bus) configurations, using Liebert's unique Load Bus Sync™ option. Both Load Bus Sync and 1+1 Redundant configurations can be factory-installed or retrofitted to existing Npower installations.

Easy to Purchase and Install



The Liebert Npower can be as simple or complete as you need it to be. With matching battery cabinets, maintenance bypass cabinets, Slim-Line power distribution cabinets and Paralleling Cabinets, the Npower can be a bolt-together system.

All bolt-on cabinets have casters and leveling feet, to simplify installation. Furthermore, power cables and control wiring harnesses between cabinets are included for all cabinets (except Paralleling Cabinets), saving time and cost.

Smallest Complete-System Footprint

The Liebert Npower achieves a small footprint despite being a full-featured, double-conversion UPS. Furthermore, Liebert understands that real systems have battery cabinets, maintenance bypass cabinets and some type of power distribution cabinets. Therefore, our design goal was to build complete systems, in all their variant forms, in the smallest practical size consistent with good engineering practices. Consider this:

- No size penalty for 208 VAC input or output. For each kVA rating, all input voltages and all output voltages fit in the same size package.
- Input isolation and bypass isolation transformers fit inside the same package.
- Battery trays slide out the front for maintenance.
- Bypass isolation transformers can also be built into your maintenance bypass cabinet.
- The Slim Line distribution unit adds just 10 inches to the width of the UPS module, but gives you 42 or 84 poles.

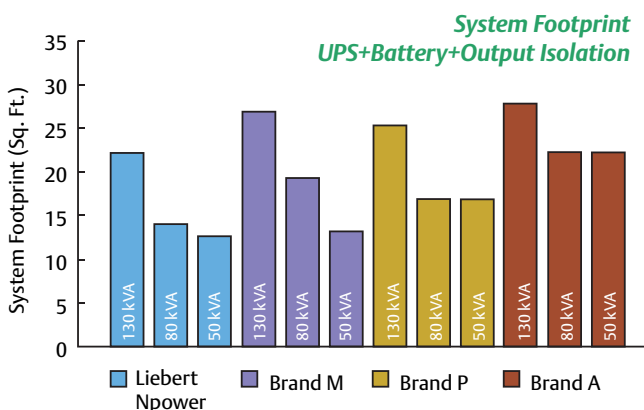

Liebert Npower: Configurations for Any Application

Input and Output Configurations

Single or Dual Input:

- Single-input UPS products are often favored in this power range (30 to 130 kVA). This is the simplest and lowest-cost solution. It features a single input bus, with both the input and bypass circuits fed from the same external feeder breaker.
- Dual-input UPS products have separate busses for the rectifier input and the bypass circuit. This adds a measure of fault tolerance, because a single external breaker failure will not cause the load to fail. It also adds cost: an additional input feeder breaker and more input cabling.

Isolated or Non-Isolated Neutral

Proper grounding is essential for reliable UPS operation. The installing contractor must ensure the integrity of the ground and neutral connections and select the UPS best suited for the facility.

The Liebert Npower can be ordered with or without an isolated bypass neutral. With an isolated neutral, the UPS contains an internal bypass isolation transformer and does not require an input neutral brought in from the service entrance. Shown below are the various configurations and their applications:

- A non-isolated neutral is the lowest-cost option, but requires the installing contractor to pull a neutral line from service entrance. This configuration can support three-wire or four-wire-plus-ground loads where the input and output voltages are the same.
- An isolated neutral with Delta-Wye isolation transformer is able to support 3-wire or 4-wire-plus-ground loads of any sort. The output is phase-shifted 30 degrees from the input.
- An isolated neutral with Wye-Wye isolation transformer is able to support 3-wire loads at the supply voltage. The output is in phase with the input. This configuration cannot support 4-wire loads.

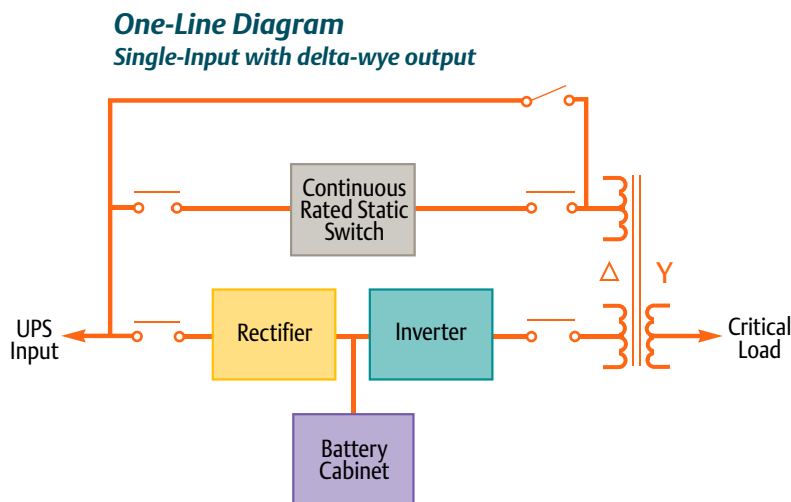

Specific Configurations

Single Input Configurations

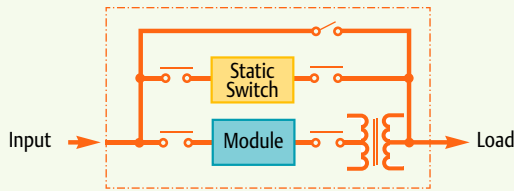

Configuration A & B With Non-Isolated Bypass

This configuration is for applications where the input is 4-wire plus ground. Output voltage must be the same as the input voltage. This configuration cannot have the neutral-to-ground bond at the UPS module. The output is 4-wire plus ground. The output is in phase with the input.

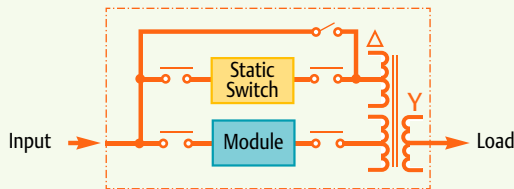

Configuration D & E With Load Neutral Isolation

This configuration is for applications where the UPS provides isolation on both the inverter and the bypass circuit. This configuration has the neutral-to-ground bond at the UPS module. The input is 3-wire plus ground, and the output is 4-wire plus ground. The output is 30° phase-shifted from the input.

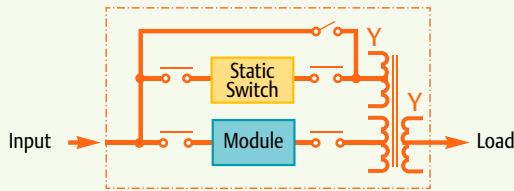

Configurations R & S With Load Neutral Isolation

This configuration is for applications with 480 VAC input and 480 VAC output, and there are no line-to-neutral loads. The UPS provides isolation on both the inverter and the bypass circuit. This configuration has the neutral-to-ground bond at the UPS module. The input and output are both 3-wire plus ground. The output is in phase with the input.

Dual Input Configurations

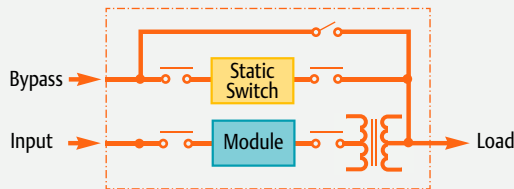

Configuration A & B: With Non-Isolated Bypass

This configuration is for applications where the bypass input is 4-wire plus ground. Output voltage must be the same as the bypass input voltage. The rectifier input is 3-wire plus ground. The output is 4-wire plus ground. The output is in phase with the bypass input.

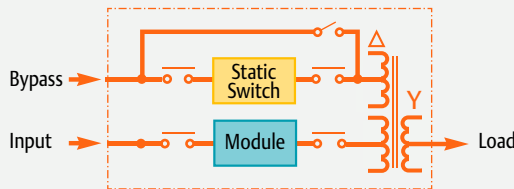

Configurations D & E: With Load Neutral Isolation

This configuration is for applications where the UPS provides isolation on both the inverter and the bypass circuit. This configuration has the neutral-to-ground bond at the UPS module. The rectifier and bypass inputs are 3-wire plus ground, and the output is 4-wire plus ground. The output is 30° phase-shifted from the bypass input.

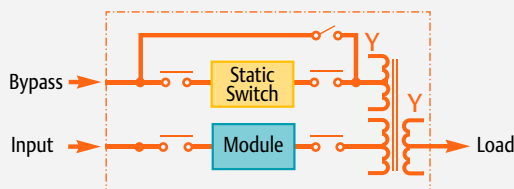

Configurations R & S: With Load Neutral Isolation

This configuration is for applications with 480 VAC bypass input and 480 VAC output and there are no line-to-neutral loads. The UPS provides isolation on both the inverter and the bypass circuit. This configuration has the neutral-to-ground bond at the UPS module. The rectifier and bypass inputs and the output are all 3-wire plus ground. The output is in phase with the bypass input.

Npower 1+1 Redundant: A Simpler Way to Improve Availability

The Liebert Npower 1+1 Redundant system is an elegantly simple way to create a parallel-redundant UPS without the cost or complexity of external system controls. Adding a redundant UPS module to a single-module system improves maintainability, because the second module can support the load while the first is being serviced. A redundant module also improves fault tolerance, because a single failure will still leave an intact UPS to support the critical load.

Liebert has nearly 30 years of experience building multi-module UPS systems, but the majority of these systems have system-level controls. These controls are necessary for large-scale power systems, but are less important for smaller systems. The Liebert Npower 1+1 Redundant system strikes a good balance between the simplicity of a single module and the performance of a multi-module system.

No System-Level Controls

All control logic is contained within the individual modules. Unlike conventional multi-module systems, there is no system-level LCD panel or static bypass switch. The module-level static bypass switches work in coordination to provide exceptional overload protection, plus seamless transfers between bypass and online operating modes.

Furthermore, the traditional system control cabinet is replaced by a simple paralleling cabinet. Normal operations can be handled efficiently at the individual module control panels.

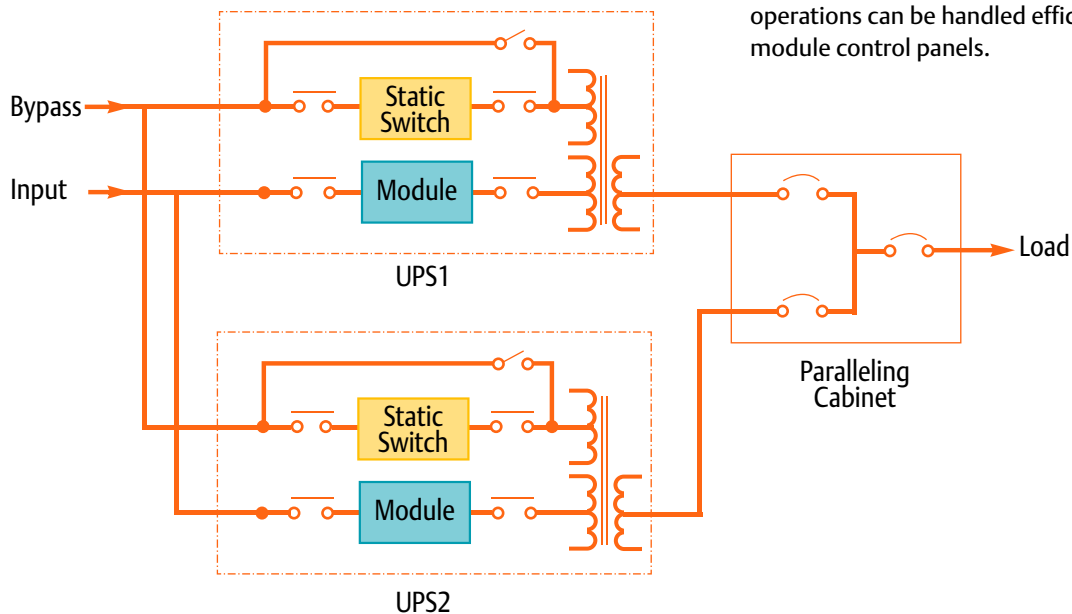

Paralleling Cabinets: Better Solutions

Liebert Npower 1+1 Paralleling Cabinets feature three circuit breakers: two module disconnect breakers and a system output breaker. The third breaker meets NEC requirements for a system output breaker. Some competitor products only have the two module disconnect breakers. This forces the installing contractor to size, purchase, coordinate, install and run conduit to an external output breaker.

Our standard wall-mounted panelboards give great flexibility in component placement. Consult your Liebert sales representative for optional cabinet configurations.

Better than Wireless

Both UPS modules in a Liebert Npower 1+1 system are completely independent. They function as true peers, rather than as master or slave.

A single Category 5 Ethernet cable connects the modules. The cable enables the modules to “learn” and calibrate themselves during initial system start-up. After start-up, the cable optimizes system communications and performance in several areas. It enables the modules to load share with a precision of +/- 1%. It also enables the modules to load share during battery discharge, improving battery runtimes by 15-30%.

Although it enhances system performance, the cable is not required for system operation. Should the cable become severed or disconnected, the Npower modules will continue to share load within +/- 5% (typically within +/- 3%). The system will continue to provide conditioned power to the critical load without interruption. Likewise, the modules will still be capable of automatic fault isolation, and the operator can still perform manual transfers to and from bypass.



In summary, Liebert system designers chose the performance advantages of a wired paralleling system, but the wires were not permitted to become a failure mode.

New or Retrofit

All configurations of Liebert Npower modules can be used in 1+1 Redundant systems. New systems can be ordered with all the components included. Installed systems can be retrofitted with a simple kit.

Liebert Monitoring Solutions: When You Need To Know

Liebert has built advanced monitoring and communications capabilities into the Liebert Npower UPS system. Liebert monitoring and control products allow you to take full advantage of these features. You will find a full range of monitoring and control systems, communications modules and other equipment designed to interface with a variety of communication protocols, operating platforms and building management systems. Knowing what is happening with your power equipment, so you can keep it at peak operating efficiency, is vital to system reliability.

Important facility operational and status information needs to be communicated by different means with varying levels of importance. This is why Liebert gives you so many ways to supervise your enterprise:

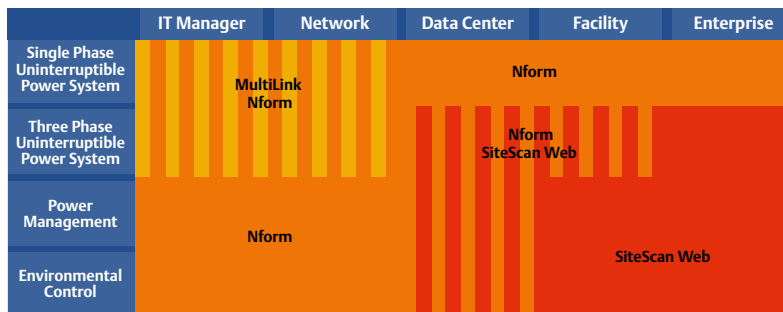

Liebert SiteScan™ Web Enterprise Monitoring Systems

Liebert SiteScan™ Web is a comprehensive critical systems monitoring solution dedicated to ensuring reliability through graphics, event management and data extrapolation. The standard Web interface allows users easy access from “anywhere” at “anytime.”

- Single and multi-site applications.
- Event management and unit control.
- Trend and historical data captures and reporting.
- Full ASHRAE BACnet compatibility.
- Java based.
- Windows 2000 and XP compatible.

Network-Based Monitoring Systems

The Nform family of monitoring software and communications hardware solutions combines the coverage of facility monitoring with the efficiency of a network-based system. They provide a cost-effective, centralized monitoring solution flexible enough to support your critical system configurations while utilizing your existing distributed infrastructure.

Stand-Alone Monitoring Solutions

UPS shutdown software, as well as autonomous microprocessor controlled modules, are available to provide supervision, control and remote alarm notification for Liebert power equipment.

Network-Based Monitoring Systems

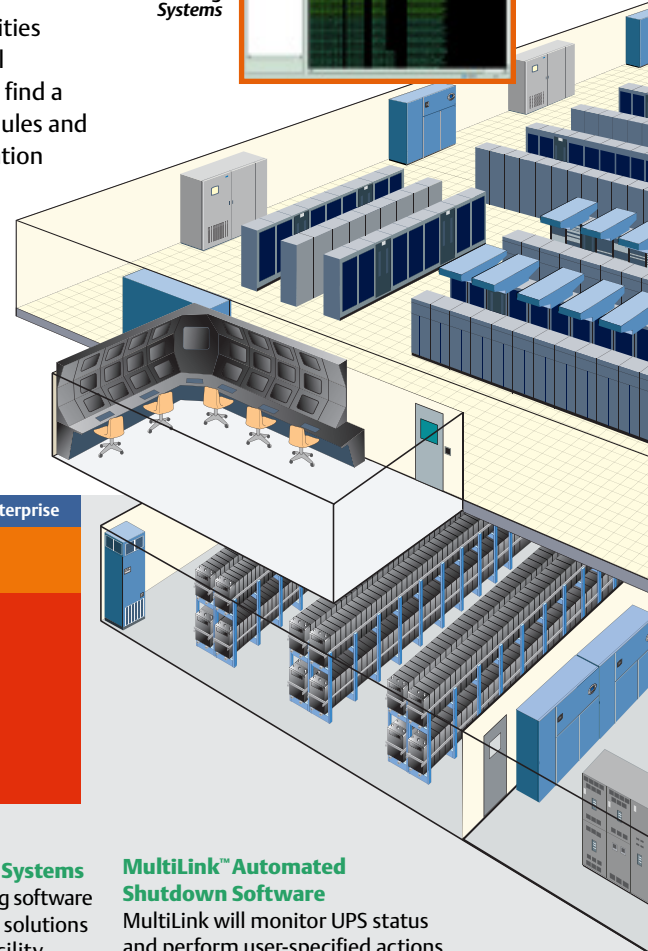
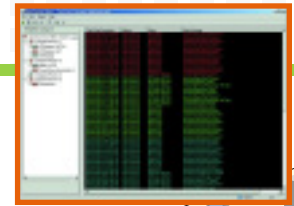

MultiLink™ Automated Shutdown Software

MultiLink will monitor UPS status and perform user-specified actions to execute notifications and provide automated, unattended system shutdown to protect critical data during extended power outages.

Universal Monitor

All-purpose microprocessor-based alarm and notification unit that allows a variety of Liebert equipment to be monitored and controlled both remotely and locally from a single point.

Emerson Network Power Service Business

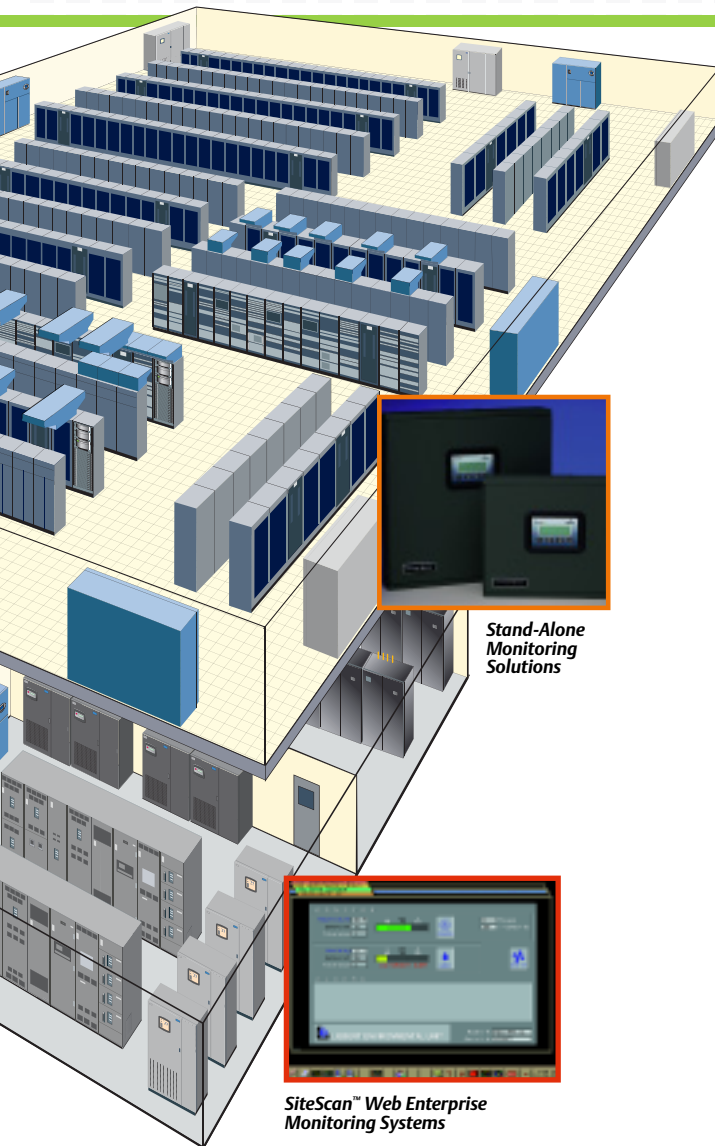

Enterprise Remote Monitoring Service

An integrated solution from Emerson Network Power, our Enterprise Remote Monitoring Service integrates four key competencies to maximize availability:

- Alarm Management, Diagnostics and Response
- Predictive Maintenance
- Enterprise-Wide Support
- Industry-Leading Service

Alarm Management, Diagnostics and Response

We'll manage alarm activity based on a pre-defined set of escalation procedures. Our specialists review all alarm activity from your enterprise and evaluate them as an integrated system. And, our 24x7 Customer Response Center is ready to respond to any alarm precisely when it occurs.

Predictive Maintenance

Our High Availability Response Center polls your equipment on regular intervals. Our certified engineers analyze the trended data points over time to reveal maintenance that could be required—identifying issues before they become problems.

Enterprise-Wide Support

We can monitor all your critical support equipment—regardless of manufacturer or location.

Industry-Leading Service

The service business of Emerson Network Power is the largest service organization in the world dedicated to maximizing availability of infrastructure required for mission-critical systems. We offer:

- Global service with over 2000 certified OEM engineers / technicians
- 2-hour mean time to respond
- Web-based monitoring and reporting
- 24x7 Customer Response Center
- Global multi-tiered new parts availability

General Specifications

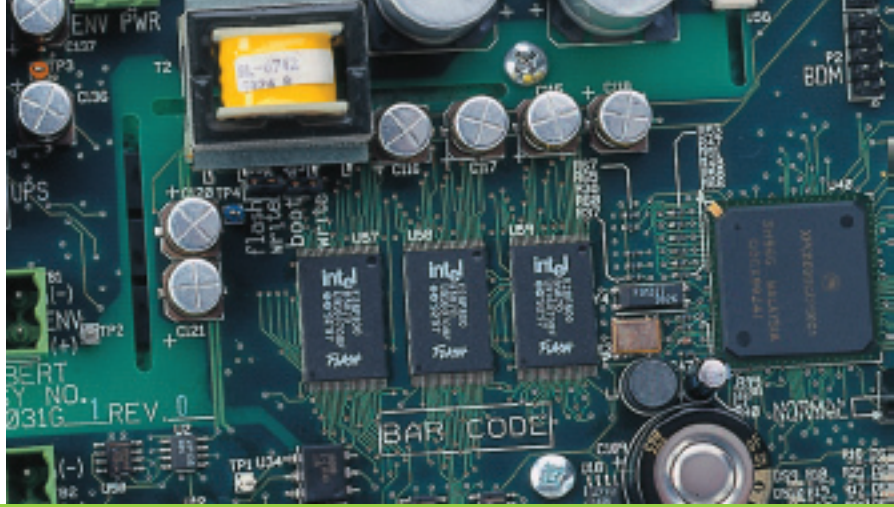

Specifications

UPS Rating		Battery	Maximum Heat	Dimensions (WxDxH) ²		Approximate Weight ³	
kVA	kW	Nominal (VDC)	Dissipation At Full Load (BTU/Hr) ¹	Inches	MM	Pounds	KG
30	24	480	8,500	31.7x32.5x71	805x825x1800	2,200	1,000
40	32	480	11,000	31.7x32.5x71	805x825x1800	2,200	1,000
50	40	480	14,000	31.7x32.5x71	805x825x1800	2,200	1,000
65	52	480	18,000	39.4x32.5x71	1000x825x1800	2,700	1,225
80	64	480	22,000	39.4x32.5x71	1000x825x1800	2,700	1,225
100	80	480	26,000	49.2x32.5x71	1250x825x1800	3,800	1,725
130	104	480	33,000	49.2x32.5x71	1250x825x1800	3,800	1,725

¹ Heat dissipation figures are for worst-case configurations (including 208 VAC, input and output), supporting 100% load at rated power factor.

² Dimensions and weights do not include battery or maintenance bypass cabinets.

³ Weights are for heaviest models, with 208 VAC input.

Liebert Npower Matching Battery Cabinet

Model	Run Time (minutes)							Dimensions (WxDxH)		Weight	
	30 kVA	40kVA	50kVA	65kVA	80kVA	100kVA	130kVA	inches	mm	lbs	kg
1FJ	12	7	-	-	-	-	-	25x32.5x71	635x825x1800	1,600	725
1HJ	21	14	10	7	5	-	-	25x32.5x71	635x825x1800	1,800	815
1LJ	28	20	14	8	5	-	-	25x32.5x71	635x825x1800	2,350	1,065
1MJ	36	25	18	12	8	5	-	25x32.5x71	635x825x1800	2,350	1,065
1PJ	53	38	28	20	15	10	-	25x32.5x71	635x825x1800	3,000	1,360
1PJ (130)	-	-	-	-	-	-	7	49x32.5x71	1250x825x1800	3,350	1,520
1RJ	62	45	34	25	19	13	9	49x32.5x71	1250x825x1800	3,700	1,680
1UJ	72	52	39	30	23	17	12	49x32.5x71	1250x825x1800	4,000	1,815
1WJ	104	74	55	40	33	25	16	49x32.5x71	1250x825x1800	5,050	2,290
2PJ	126	83	67	50	38	28	-	(2) 25x32.5x71	(2) 635x825x1800	6,000	2,720
2PJ (130)	-	-	-	-	-	-	20	(2) 49x32.5x71	(2) 1250x825x1800	6,700	3,040
2RJ	144	104	76	55	45	35	25	(2) 49x32.5x71	(2) 1250x825x1800	7,400	3,360
2UJ	156	111	90	67	52	40	30	(2) 49x32.5x71	(2) 1250x825x1800	8,000	3,630
2WJ	-	-	-	97	74	55	40	(2) 49x32.5x71	(2) 1000x825x1800	10,100	4,580
3PJ	204	145	108	78	63	48	-	(3) 25x32.5x71	(3) 635x825x1800	9,000	4,080
3PJ (130)	-	-	-	-	-	-	35	(3) 49x32.5x71	(3) 1250x825x1800	10,050	4,560
3RJ	223	161	129	94	72	54	39	(3) 49x32.5x71	(3) 1250x825x1800	11,100	5,340
3UJ	265	187	142	105	81	65	48	(3) 49x32.5x71	(3) 1250x825x1800	12,000	5,445
3WJ	421	302	217	157	154	94	69	(3) 49x32.5x71	(3) 1250x825x1800	15,150	6,870
4PJ	301	206	154	111	90	68	-	(4) 25x32.5x71	(4) 635x825x1800	12,000	5,440
4PJ (130)	-	-	-	-	-	-	50	(4) 49x32.5x71	(4) 1250x825x1800	13,400	6,080
4RJ	329	224	182	134	102	77	55	(4) 49x32.5x71	(4) 1250x825x1800	14,800	6,720
4UJ	377	266	201	147	111	91	67	(4) 49x32.5x71	(4) 1250x825x1800	16,000	7,260
4WJ	480	423	320	222	180	135	97	(4) 49x32.5x71	(4) 1250x825x1800	20,200	9,160

Input

Voltage: 208, 220, 240, 480 or 600 VAC, 60 Hz. 3-phase, 3-or 4-wire plus ground

Voltage Range: +10, -15% (no battery discharge at -20%)

Frequency Range: 60 Hz, ± 5 Hz

Current Distortion: 10% maximum reflected THD at full load with optional input filter. 30% THD without filter.

Current Limit: 115% of full load input current

Current Walk-in: 20 seconds to full load.

Power Factor: Up to 0.96 lagging at full load with optional input filter. 0.80 lagging minimum at full load without optional input filter.

Surge Protection: Sustains input surges without damage, per criteria listed in ANSI C62.41-1980, A & B (IEEE 587).

Output

Voltage: 208, 220, 240, 480 or 600 VAC, 60 Hz, 3-phase, 4-wire plus ground.

Voltage Adjustment Range: $\pm 5\%$.

Voltage Regulation:

$\pm 0.5\%$ for balanced load

$\pm 1.0\%$ for 100% unbalanced load.

Dynamic Regulation: $\pm 2.5\%$ deviation for 100% load step. $\pm 1\%$ for loss or return of AC input.

Transient Response Time: Recover to steady state within 1 cycle.

Voltage Distortion: For linear loads, 1% THD. Less than 2.5% THD for 100% nonlinear loads (3:1 crest factor) without kVA/kW derating.

Phasing Balance: $120^\circ \pm 0.5^\circ$ for balanced load. $120^\circ \pm 1^\circ$ for 100% unbalanced load. Frequency Regulation: $\pm 0.1\%$.

Load Power Factor Range: 1.0 to 0.7 lagging without derating.

Overload: 125% of full load for ten minutes. 150% for one minute with true sinusoidal waveform.

Environmental

Operating Temperature: 0° to 40°C (UPS), 20° to 30°C (battery)

Non-Operating Temperature: -20°C to 70°C .

Relative Humidity: 0-95% non-condensing

Operating Altitude: Up to 6,600 feet (2000 meters) without derating.

Acoustical Noise: Less than 65 dBA typical, measured 1 meter from the unit.

Standards

ETL Listed to UL 1778 and UL 924 UPS standards, and CSA certified. Meets current requirements for safe high-performance UPS operation.

Standard Features

Like other Liebert UPS products, the Liebert Npower includes some features that are options (or not available) for some competitors:

- True double-conversion topology, for protection against 100% of power \disturbances.
- Internal bypass switch enables you to isolate the UPS for maintenance.
- Continuous-duty static switch performs in pulsed-parallel mode for supplying fault current and momentary overloads, and can operate continuously for longer-duration events.
- Internal output isolation transformer protects your critical load from \common-mode noise and harmful DC offsets. In some configurations, it \provides a separately derived source, to support 4-wire loads without having to pull a neutral line from the \service entrance.
- Automatic input filter disconnect isolates the input filter capacitors at light loads to avoid presenting a leading power factor to the utility or backup generator.
- Backlit LCD graphic display enables easy navigation between the graphic mimic screen and the menu screens.
- Event Log can display up to 512 time-and-date-stamped alarm events.
- Battery self-test helps verify the battery's readiness to carry the critical load.
- Battery temperature-compensated charging prevents overcharging in high ambient operating temperature or undercharging in cold weather.

- Battery Cycle Monitor records up to 132 battery discharge events.
- Battery Time Remaining feature displays backup time remaining at present connected load.
- On-generator battery charge limit reduces recharge current until the utility AC power is restored.
- Front-panel control of all configuration and field-adjustment options simplify installation and maintenance.
- Top-and-bottom cable entry gives the installer more options for equipment location.
- Two-hole bus bar landing space and accessible terminal blocks for options can simplify installation.
- Casters under the unit are helpful when a forklift is not readily available.
- One-button startup for simpler operation.

Options and Accessories

- Matching valve-regulated lead-acid battery packs
- Matching maintenance bypass cabinet
- Matching bolt-on power distribution unit, with one or two 42-pole panels
- Input filter/power factor correction
- Internally mounted input isolation transformer
- Load Bus Sync™ Systems
- 1+1 Redundant Systems
- Flooded rack-mounted battery systems
- SNMP, SiteScan and other communications interfaces:
- Remote monitor panel
- Alarm status contacts
- Customer alarm inputs

Ensuring The High Availability Of Mission-Critical Data And Applications.

Emerson Network Power, the global leader in enabling business-critical continuity, ensures network resiliency and adaptability through a family of technologies – including Liebert power and cooling technologies – that protect and support business-critical systems. Liebert solutions employ an adaptive architecture that responds to changes in criticality, density and capacity. Enterprises benefit from greater IT system availability, operational flexibility, and reduced capital equipment and operating costs.

Liebert Corporation

1050 Dearborn Drive
P.O. Box 29186
Columbus, Ohio 43229
800 877 9222 Phone (U.S. & Canada Only)
614 888 0246 Phone (Outside U.S.)
614 841 6022 FAX

Via Leonardo Da Vinci 8
Zona Industriale Tognana
35028 Piove Di Sacco (PD)
Italy
39 049 9719 111 Phone
39 049 5841 257 FAX

Emerson Network Power Asia Pacific
7/F., Dah Sing Financial Centre
108 Gloucester Rd, Wanchai
Hong Kong
852 25722201 Phone
852 28029250 FAX

liebert.com

24 x 7 Tech Support

800 222 5877 Phone
614 841 6755 (outside U.S.)

While every precaution has been taken to ensure accuracy and completeness in this literature, Liebert Corporation assumes no responsibility, and disclaims all liability for damages resulting from use of this information or for any errors or omissions.

© 2005 Liebert Corporation. All rights reserved throughout the world. Specifications subject to change without notice.

All names referred to are trademarks or registered trademarks of their respective owners.

© Liebert and the Liebert logo are registered trademarks of the Liebert Corporation.

SL-24529 (R11/06) Printed in USA

Emerson Network Power.

The global leader in enabling Business-Critical Continuity™.

- AC Power
- Embedded Computing
- Outside Plant
- Racks & Integrated Cabinets
- Connectivity
- Embedded Power
- Power Switching & Controls
- Services
- DC Power
- Monitoring
- Precision Cooling
- Surge Protection