

Liebert®Nfinity™ Maintenance Bypass Cabinet

User Manual



TABLE OF CONTENTS

IMPORTANT SAFETY INSTRUCTIONS	1
GLOSSARY OF SYMBOLS	2
1.0 GENERAL DESCRIPTION	3
1.1 System Description	3
1.1.1 Features	3
1.1.2 Standard Components	3
1.1.3 Options	3
2.0 MODES OF OPERATION	7
2.1 UPS Mode	7
2.2 Bypass Mode	7
3.0 MAJOR COMPONENTS	8
3.1 Bypass Switch	8
3.2 User Selectable Output Distribution	8
3.2.1 Optional Transformer	8
4.0 PREPARATION	9
4.1 Inspection	9
4.2 Environment	9
4.3 Required Setup Equipment	9
4.4 Site Preparation	9
5.0 UNLOADING	10
5.1 Unloading the Liebert Nfinity Maintenance Bypass Cabinet	10
5.2 Stationary Mounting	11
6.0 CABLE INSTALLATION	12
6.1 Wiring Preparation	12
6.2 Preparing Internal Wiring	12
6.3 Dual Source Configuration	12
6.4 Removing the Cover Plates	14
6.5 Power Cable Installation	14
6.6 REPO Connection	14
6.7 Input and Output Wiring	15
7.0 OPERATION	20
7.1 Start-Up and Initialization	20
7.2 Shutting Down the UPS	20
7.3 Transferring the System from UPS to Maintenance Bypass Operation	20
7.4 Transferring the System from Maintenance Bypass to UPS Operation	20

8.0	MAINTENANCE	21
8.1	Proper Care	21
8.2	Scheduled Maintenance	21
8.2.1	Replacing Fan Filters—Transformer Models Only	21
9.0	SPECIFICATIONS	22

FIGURES

Figure 1	Front view	4
Figure 2	Rear view (without transformer)	5
Figure 3	Rear view (with transformer)	6
Figure 4	Bypass operation modes	7
Figure 5	Clearances	9
Figure 6	Jumper removal—transformer models and non-transformer models	12
Figure 7	Liebert Nfinity Maintenance Bypass Cabinet with transformer	13
Figure 8	Liebert Nfinity Maintenance Bypass Cabinet without transformer	13
Figure 9	Electrical connections—transformer model MBC	16
Figure 10	Electrical connections—non-transformer model MBC	17
Figure 11	Connecting Liebert Nfinity to Liebert Nfinity Maintenance Bypass with transformer	18
Figure 12	Connecting Liebert Nfinity to a Liebert Maintenance Bypass Cabinet without transformer ...	19

TABLES

Table 1	Common receptacle and hardwire options	8
Table 2	Maintenance Bypass Cabinet physical data	9
Table 3	Liebert Nfinity power cable and protection ratings	14

IMPORTANT SAFETY INSTRUCTIONS

SAVE THESE INSTRUCTIONS

This manual contains important instructions that should be closely followed during installation and maintenance of this Maintenance Bypass Cabinet.

This product is designed for commercial/industrial use only. This product is not intended for use with life support and other designated “critical” devices. Maximum load must not exceed that shown on the UPS and the Maintenance Bypass Cabinet rating label.



WARNING

Lethal voltages may be present within this unit even when it is apparently not operating. Observe all cautions and warnings in this manual. Failure to do so may result in serious injury or death. Never work alone.

The Liebert Nfinity Maintenance Bypass Cabinet is designed for use on properly grounded (earthed) 208/240VAC, 60Hz supply, for installation by qualified personnel. This UPS equipment is intended to be installed by a qualified / certified electrician who must review and approve customer supplied wiring, circuit breakers, intended loads and verify correct input, output and grounded (earthed) connections to ensure compliance with technical standards and national and local electrical codes. Installation instructions and warning notices are located in the Installation section of this manual.



WARNING

To reduce the risk of fire:

- The NMB1x and NMB4x models must be connected to a circuit provided with 100 amperes maximum branch circuit overcurrent protection in accordance with applicable national and local electrical codes.
- The NMB5x and NMB8x models must be connected to a circuit provided with 125 amperes maximum branch circuit overcurrent protection in accordance with applicable national and local electrical codes.

Operate the UPS equipment in an indoor environment only in an ambient temperature range of 32°F to 104°F (0°C to 40°C). Install it in a clean environment, free from conductive contaminants, moisture, flammable liquids, gases, or corrosive substances.

Never block or insert any object into the ventilation holes or other openings.

GLOSSARY OF SYMBOLS



Risk of Electrical Shock



Indicates Warning or Caution Followed by Important Instructions

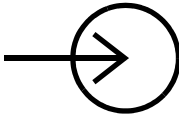

AC Input

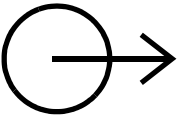

AC Output



Requests the user to consult the manual



Equipment Grounding Conductor



ON



OFF

1.0 GENERAL DESCRIPTION

Congratulations on your purchase of Liebert's Nfinity™ Maintenance Bypass Cabinet with Configurable Output Distribution. As with every Liebert product, we stand behind our quality. If you have any questions concerning this Maintenance Bypass Cabinet, please feel free to contact your local dealer, Liebert representative, or call the appropriate Technical Support number listed on the back of this manual.

To ensure proper installation and operation of this unit, please read this manual thoroughly.

Installation must be done by a qualified/certified electrician, but general operation may be performed without special training.

1.1 System Description

The Liebert Nfinity Maintenance Bypass Cabinet is intended for use with the Liebert Nfinity UPS. Typical applications include supporting workstations, servers, network, telecom or other sensitive electronic equipment.

The Liebert Nfinity Maintenance Bypass Cabinet was designed to provide maximum system availability to business critical equipment. The Liebert Nfinity Maintenance Bypass Cabinet allows for transfer of connected loads to an alternate power path allowing full isolation of the UPS. The UPS can then be turned "OFF" and removed from service with no interruption of power to connected loads.

1.1.1 Features

- Supports up to 20 kVA loads
- High speed transfer switch
- Compact design
- Highly configurable
- Multiple power path indicators

1.1.2 Standard Components

- Casters and leveling feet
- Easily accessible terminal blocks
- Supports Lockout/Tagout Program
- Support/mounting brackets for additional stability
- Provisions for hardwire output
- Dual-source compatible for increased availability

1.1.3 Options

- Output transformer for isolation
- Field-installable output distribution

Figure 1 Front view

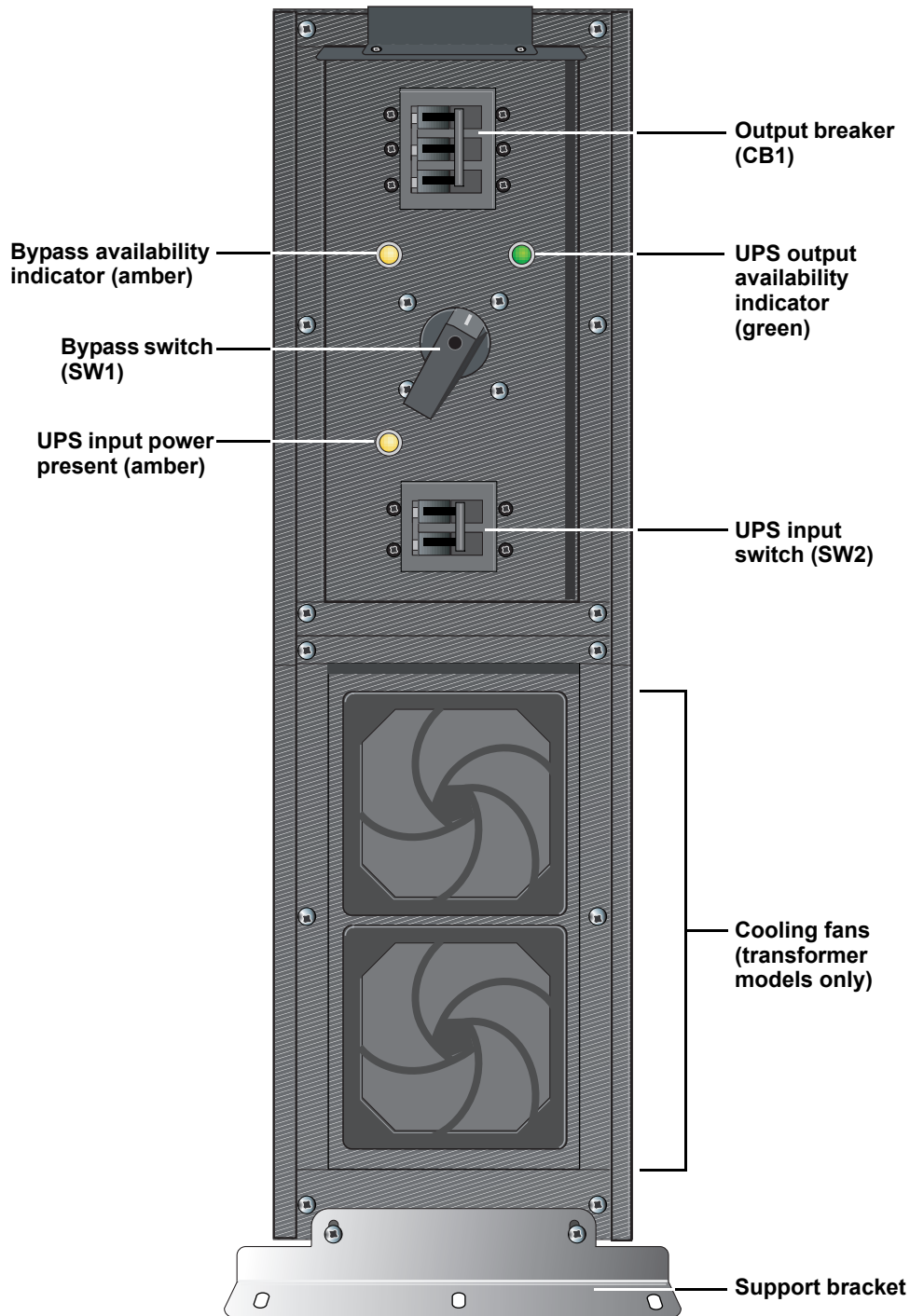

Figure 2 Rear view (without transformer)

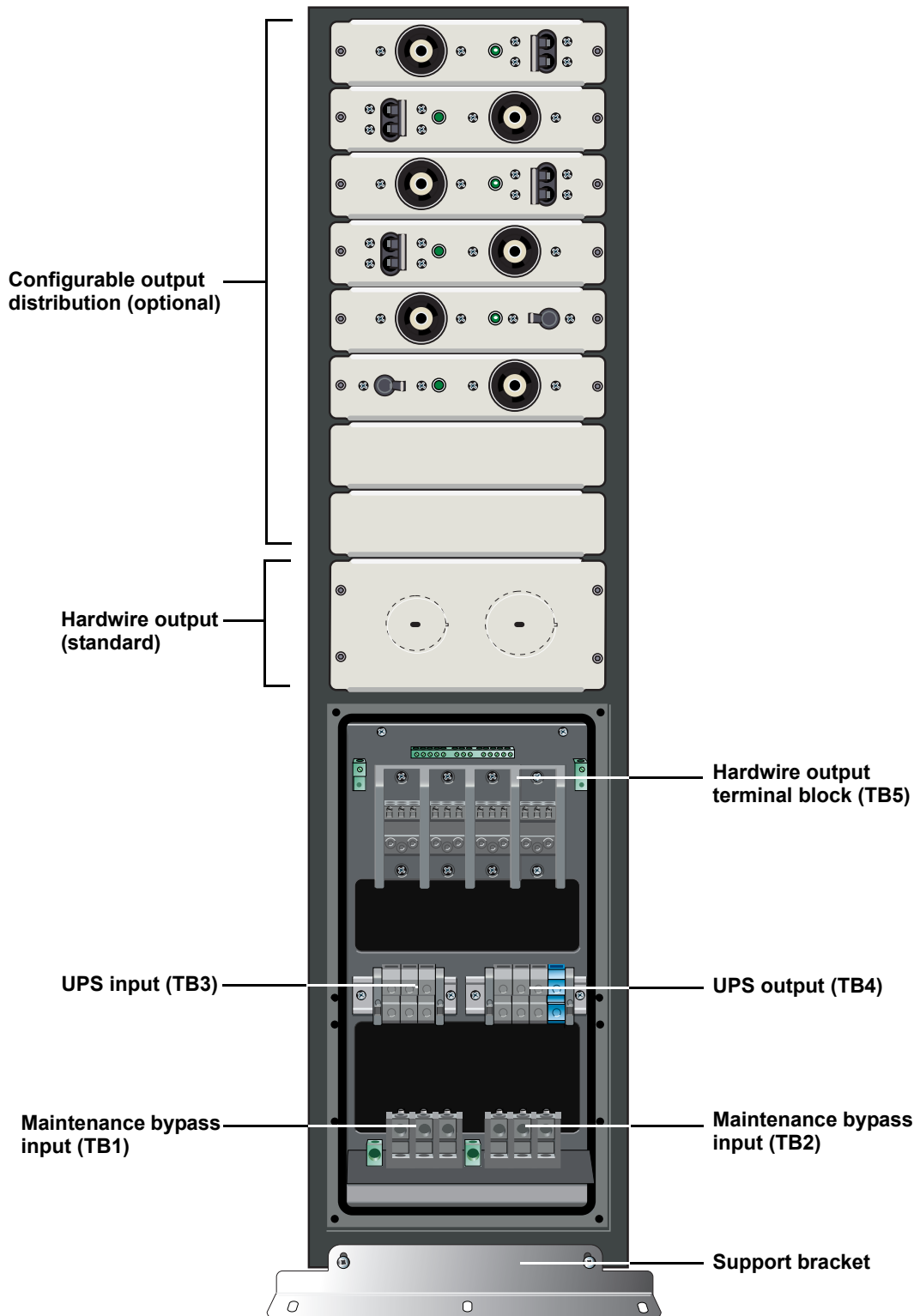
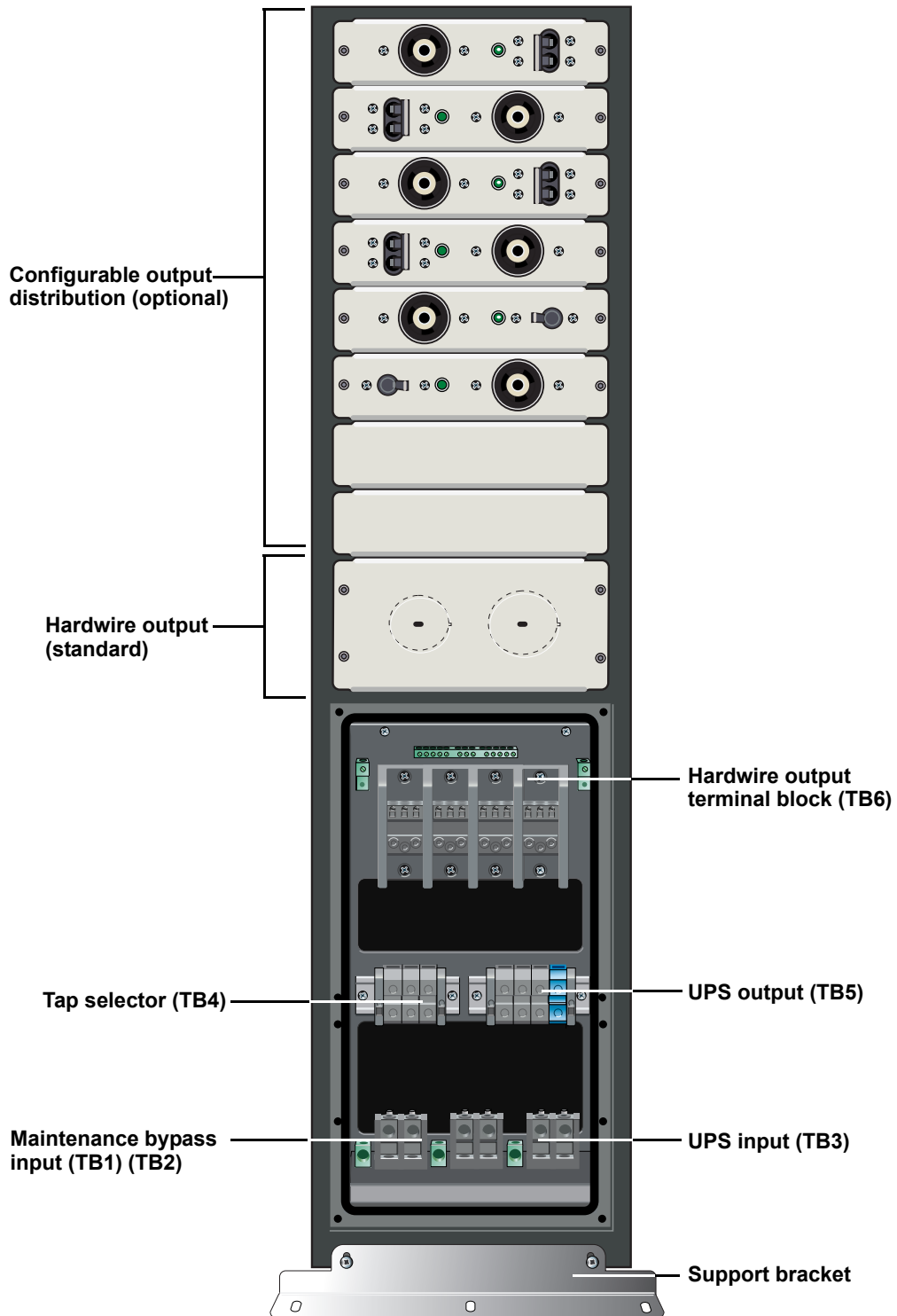

Figure 3 Rear view (with transformer)



2.0 MODES OF OPERATION

The Liebert Nfinity Maintenance Bypass Cabinet is designed to operate in two modes: UPS Mode and Bypass Mode.

2.1 UPS Mode

While the Liebert Nfinity Maintenance Bypass Cabinet is in UPS Mode, the UPS is supplying the connected load with continuous, high quality AC power. In this mode of operation, the load is protected by the UPS. The Bypass Switch rotated toward the green lamp indicates this mode.

2.2 Bypass Mode

When the Liebert Nfinity Maintenance Bypass Cabinet is in the Bypass Mode, it provides an alternate path for power to the connected equipment. Should the UPS need to be taken out of service for limited maintenance or repair, manual activation of the bypass will cause an immediate transfer of the equipment from the UPS inverter to the bypass source.

The amber lamp illuminated in the Maintenance Bypass Switch compartment indicates bypass is available. In this mode of operation the load is NOT protected by the UPS. The Bypass Switch rotated toward the amber lamp indicates this mode. See **7.0 - Operation** for instructions on use.

Figure 4 Bypass operation modes

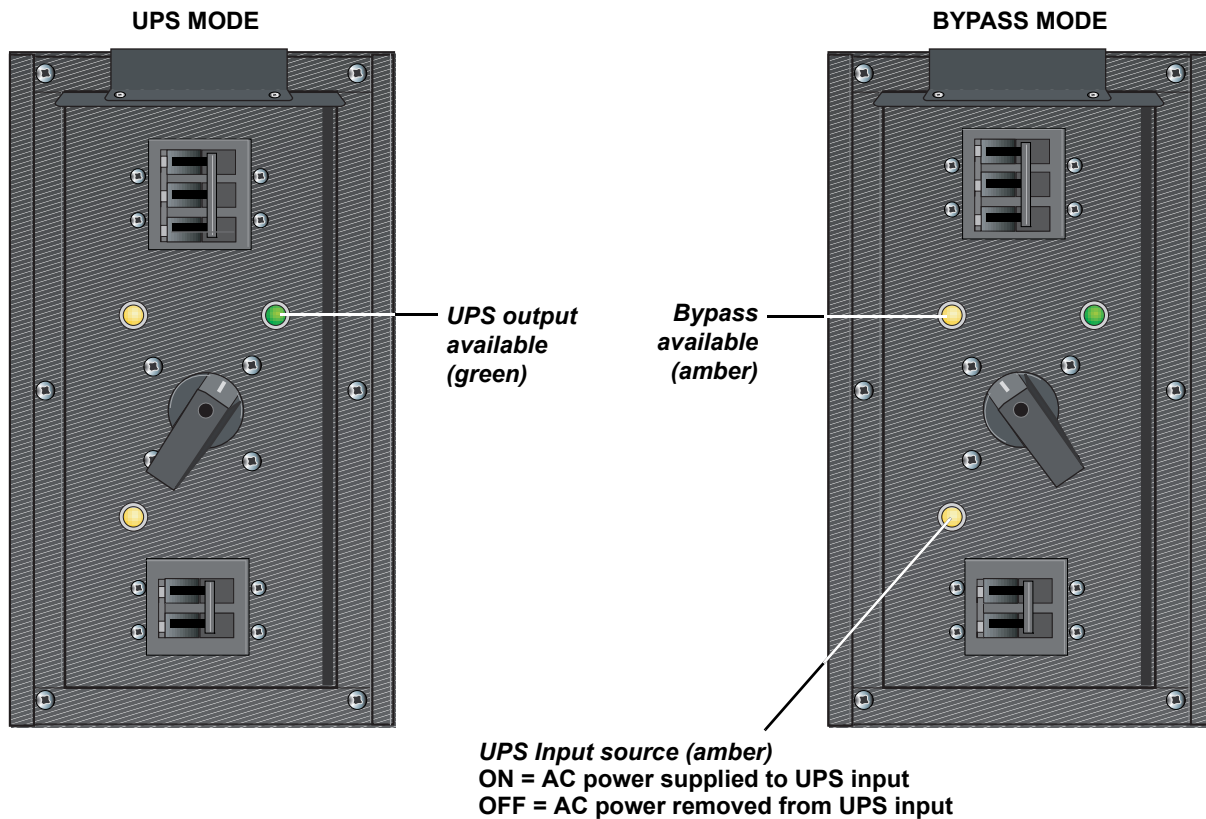

3.0 MAJOR COMPONENTS

The following is a general description of each component and its functions. Please review this section carefully, as it will give you a better understanding as to how the Liebert Nfinity Maintenance Bypass Cabinet operates.

3.1 Bypass Switch

The Bypass Switch allows easy and rapid transfer of connected loads between the UPS and Bypass source.

3.2 User Selectable Output Distribution

Several receptacle and hardwire options are available as user selectable output distribution. These are factory configured when ordered and also allow for field upgrades.

Table 1 Common receptacle and hardwire options

15 Amp Options	20 Amp Options	30 Amp Options
5-15R2	5-20R2 (T-slot)	L5-30R
L5-15R2	L5-20R	L6-30R-208
6-15R2-208	L6-20R-208	L6-30R-240
6-15R2-240	L6-20R-240	L14-30R-240
L6-15R2-208	L14-20R-240	30A, 120V, 1 pole breaker w/ 1/2" & 3/4" knockouts
L6-15R2-240	20A, 120V, 1 pole breaker w/ 1/2" & 3/4" knockouts	30A, 208V, 2 pole breaker w/ 1/2" & 3/4" knockouts
15A, 120V, 1 pole breaker w/ 1/2" & 3/4" knockouts	20A, 208V, 2 pole breaker w/ 1/2" & 3/4" knockouts	30A, 240V, 2 pole breaker w/ 1/2" & 3/4" knockouts
15A, 208V, 2 pole breaker w/ 1/2" & 3/4" knockouts	20A, 240V, 2 pole breaker w/ 1/2" & 3/4" knockouts	
15A, 240V, 2 pole breaker w/ 1/2" & 3/4" knockouts		

Other Options

- Single Position Blanking Plate
- Hardwire Option

3.2.1 Optional Transformer

Models offering a transformer are designed to accept the same input voltage as the UPS and provide 240 / 208 / 120 / 120 output. Models with transformers are provided with redundant cooling fans and user serviceable fan filters. The fans operate only when the system is in Bypass mode.

4.0 PREPARATION

These installation instructions provide all the information needed for positioning the Liebert Nfinity Maintenance Bypass Cabinet (including environmental requirements) and for connecting the input and output power cables.

4.1 Inspection

Upon receiving the Liebert Nfinity Maintenance Bypass Cabinet, examine the packaging for any signs of mishandling or damage. If any damage is noted, contact your local dealer or Liebert representative and notify your carrier.

4.2 Environment

The Liebert Nfinity Maintenance Bypass Cabinet environment must be free of conductive contaminants and excessive moisture (water condensation), flammable vapors, chemical fumes, or corrosive gases and liquids.

4.3 Required Setup Equipment

The tools below are required in order to properly set up your Liebert Nfinity Maintenance Bypass Cabinet:

- pallet jack
- 1/2" (13 mm) wrench
- torque wrench
- flat-head screwdriver
- #2 Phillips screwdriver
- 3/16" (5 mm) Allen wrench

4.4 Site Preparation

When deciding where to locate your Maintenance Bypass Cabinet, consider the weight and size of the unit. Make sure that the structural integrity of the floor can withstand the weight. Refer to the table below for dimensional considerations:

Table 2 Maintenance Bypass Cabinet physical data

Dimensions		
Model	With Transformer	Without Transformer
W x D x H In (mm)	9.5 x 26.5 x 30.4 (241.3 x 673.1 x 772.16)	
Weight	287 lb (130 kg)	85 lb (38 kg)

Check to make sure that your Liebert Nfinity Maintenance Bypass Cabinet will be located in a well-ventilated area with at least 12 inches (304mm) in front of and behind it. Transformer based models are forced air cooled with the aid of two internal cooling fans.

Figure 5 Clearances

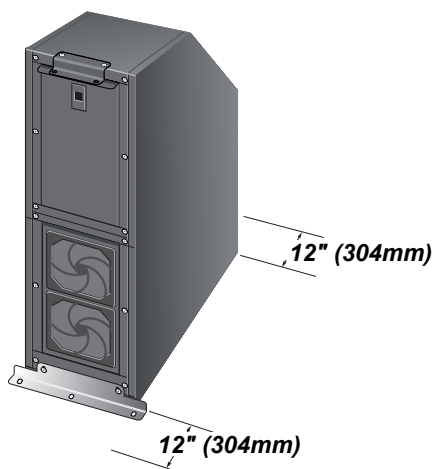

5.0 UNLOADING

The unit frame is bolted to the shipping pallet to ensure safety. Liebert recommends using a pallet jack to transport the unit to its operating location prior to unbolting the unit.

5.1 Unloading the Liebert Nfinity Maintenance Bypass Cabinet



CAUTION

This Liebert Nfinity Maintenance Bypass Cabinet is heavy (see weight in **Table 2**). At least two people should assist to unload it from the pallet.

1. Once the Liebert Nfinity Maintenance Bypass Cabinet is near the desired operating location, remove the cardboard cover.
2. Use a 1/2" (13mm) wrench to remove the eight mounting bolts (four per bracket) from the pallet brackets. Remove mounting brackets from the pallet and Liebert Nfinity Maintenance Bypass Cabinet. Keep brackets and bolts for future transportation of the Liebert Nfinity Maintenance Bypass Cabinet or for securing the cabinet to the floor.
3. Remove the metal ramp from the bottom of the pallet, rotating it 180°. Fit ramp onto opposite side of pallet (in slot) as shown below.

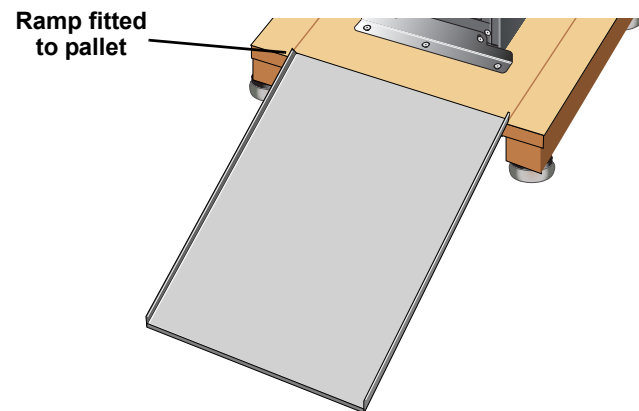
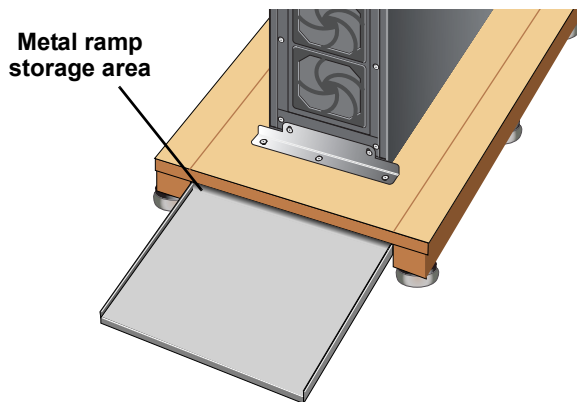
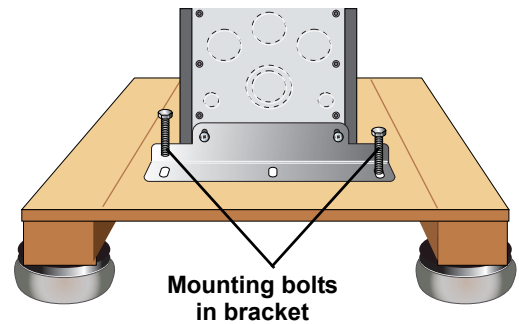

4. Using two people, slowly roll the Liebert Nfinity Maintenance Bypass Cabinet down the ramp until the unit is on a level surface (see below, left).
5. Once the Liebert Nfinity Maintenance Bypass Cabinet is in the desired location, adjust the leveling feet to secure its position (see below, right).

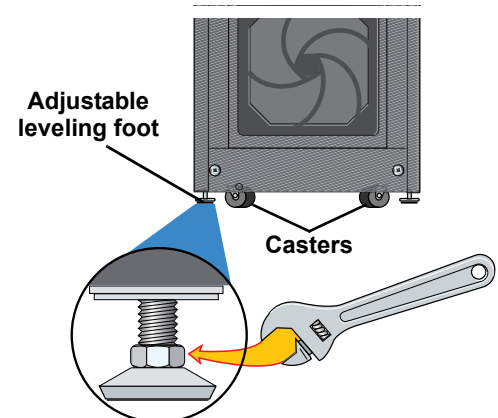
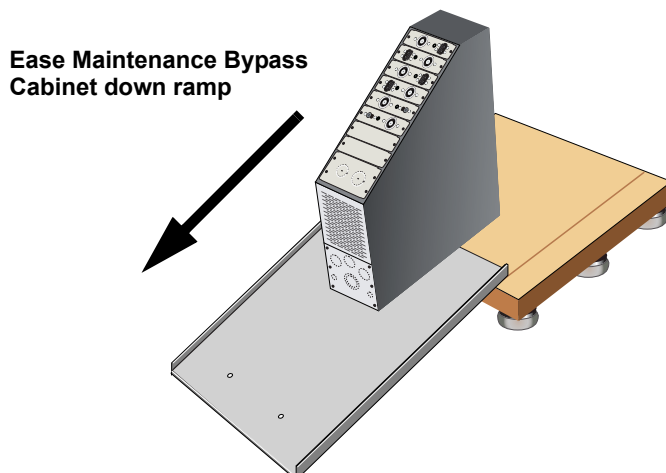

5.2 Stationary Mounting

Additional stability can be added by bolting the mounting brackets (used in shipping) to the floor.

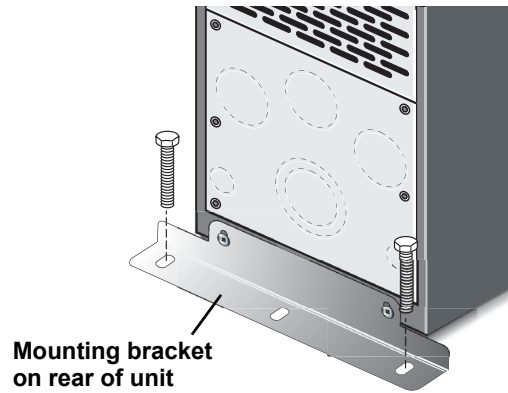

For greater stability, use a higher-grade bolt. Refer to the dimensions below when drilling holes for stationary mounting.

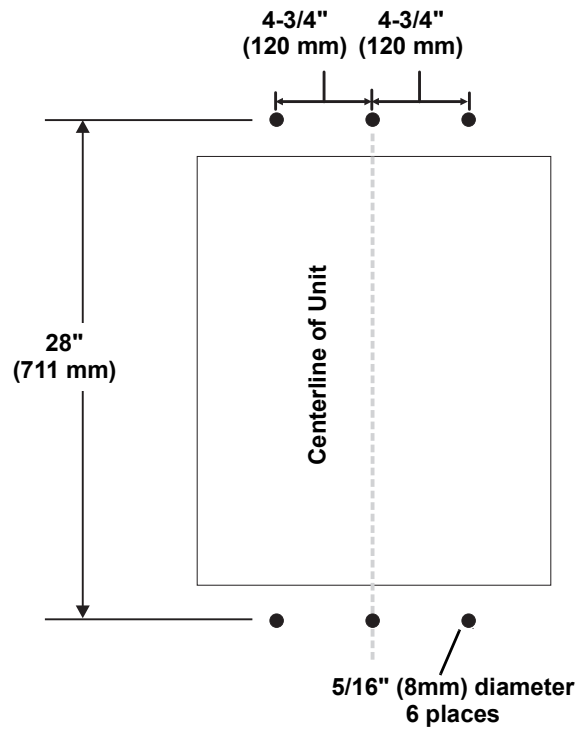

Top View of Liebert Nfinity
Maintenance Bypass Cabinet

6.0 CABLE INSTALLATION

6.1 Wiring Preparation



WARNING

Please read this section thoroughly before attempting to install wiring to this unit.

Be sure that the unit is not connected to any AC mains power source or UPS before installing any wiring to this unit. This Liebert Nfinity Maintenance Bypass Cabinet should be installed by a qualified / certified electrician.

6.2 Preparing Internal Wiring

The Liebert Nfinity Maintenance Bypass Cabinet is factory-configured for single-source installations. If your installation requires dual-source capabilities, the Liebert Nfinity Maintenance Bypass Cabinet's wiring must be modified.

6.3 Dual Source Configuration

Modifying the wiring consists of removing the jumpers between TB1 and TB2 as described below:

1. Remove cover plates.
2. Identify TB1 and TB2.
3. Using a 3/16" Allen wrench, loosen terminal mounting jumpers between TB1 and TB2.
4. Remove jumpers and retighten terminals to 50 in-lb.
5. Connect primary source to TB2 and secondary source to TB1.

Figure 6 Jumper removal—transformer models and non-transformer models

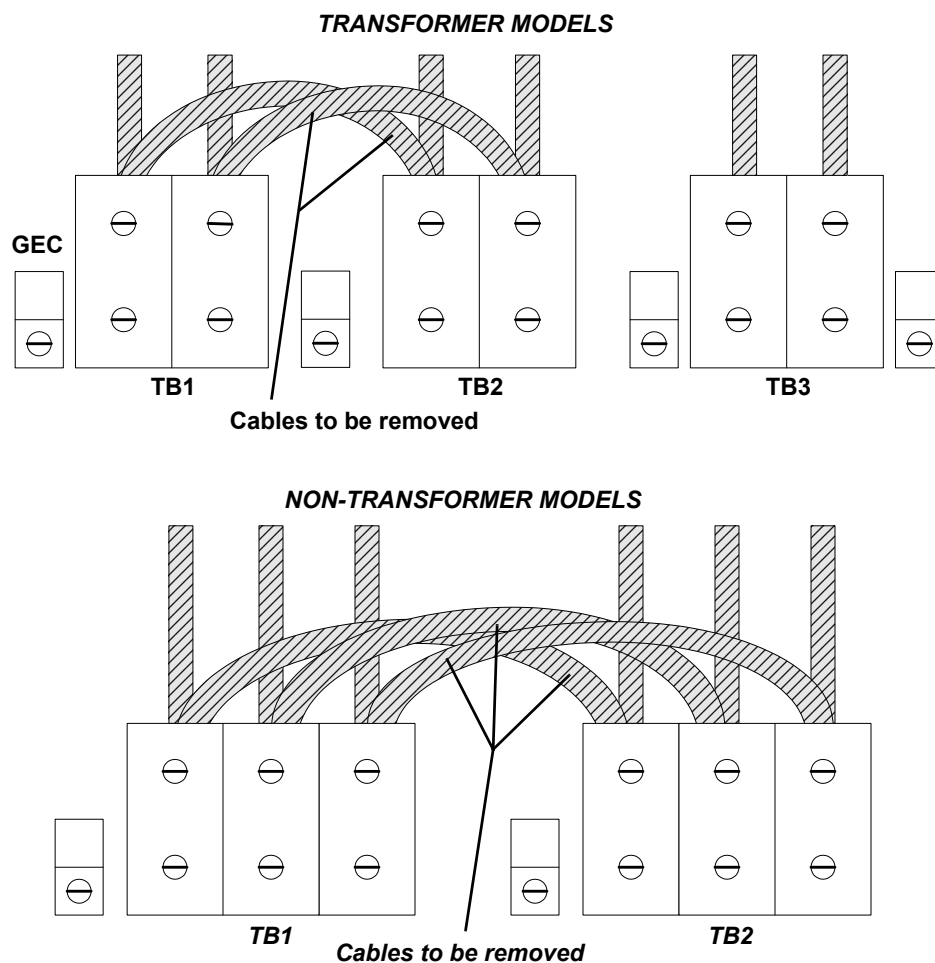

Figure 7 Liebert Nfinity Maintenance Bypass Cabinet with transformer

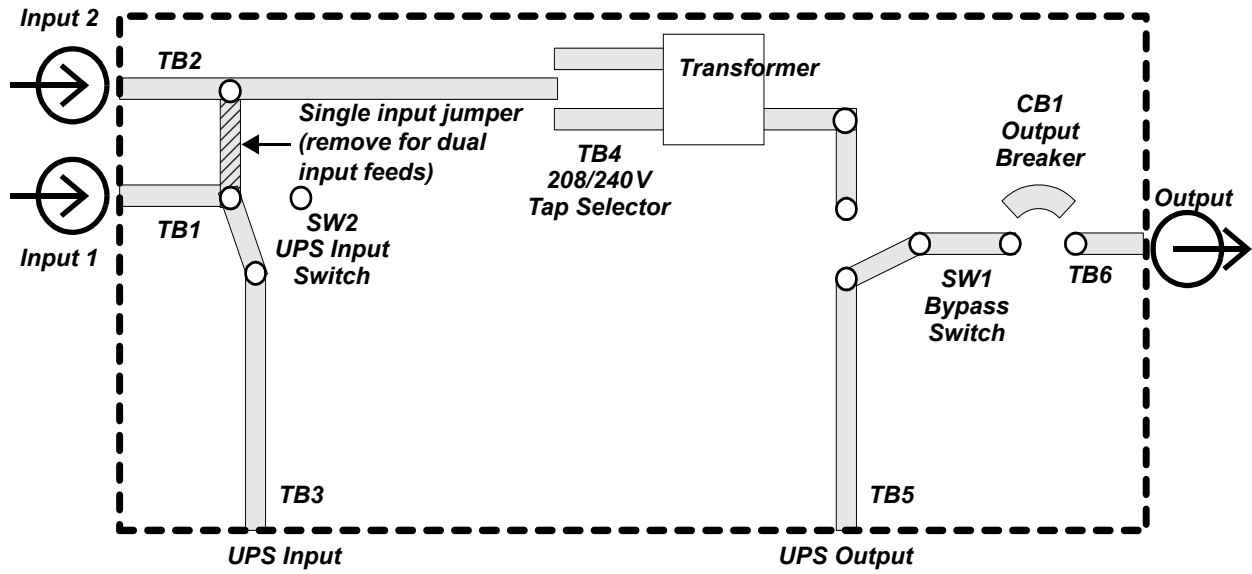
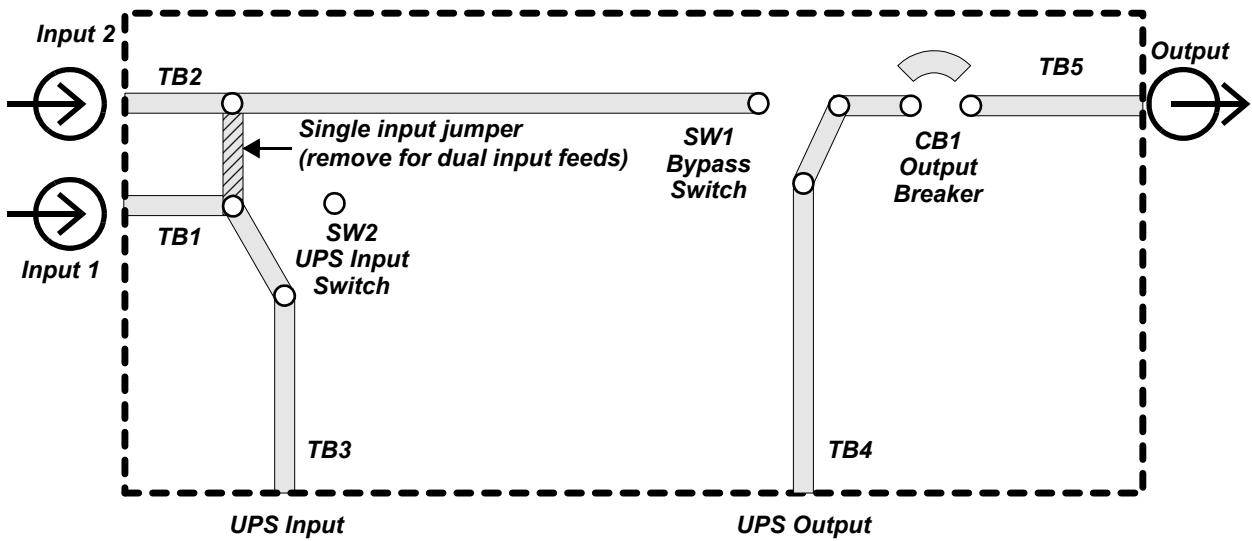

Figure 8 Liebert Nfinity Maintenance Bypass Cabinet without transformer



6.4 Removing the Cover Plates

On the back of the Liebert Nfinity Maintenance Bypass Cabinet, cover plates are over the input and output terminals (see illustration at right). Remove these using a phillips screwdriver. Keep screws and plates to one side.

6.5 Power Cable Installation

Refer to **Table 3** below when selecting cables.

Table 3 Liebert Nfinity power cable and protection ratings

Models NMB1x & NMB4x	
Max Input Current	100 A
Input Protection	100 A
Max Output Current	100 A
Input/ Output Terminal Details	Max: 2/0 (70 mm ²) Min: 6 AWG (16 mm ²)
Models NMB5x & NMB8x	
Max Input Current	125 A
Input Protection	125 A
Max Output Current	125 A
Input/ Output Terminal Details	Max: 2/0 (70 mm ²) Min: 6 AWG (16 mm ²)

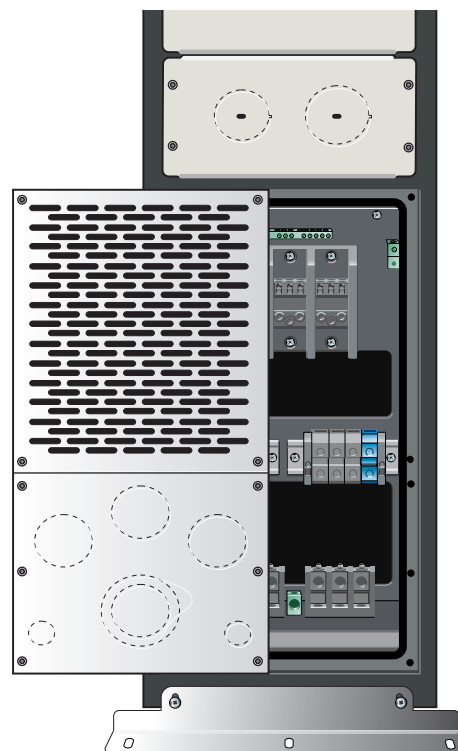

NOTES

If an output transformer is fitted, the Liebert Nfinity Maintenance Bypass has a five-cycle inrush current that is 10 times the rated output current. This must be taken into account when selecting the overload protection device at the AC input supply distribution point. To avoid random tripping on start up, it is recommended that the AC input supply be protected with a circuit breaker capable of withstanding this initial inrush.

Transient and steady state earth leakage currents may occur when starting the equipment. This should be taken into account when selecting ground current detection devices, as these will carry the earth leakage currents of both the UPS equipment and the load.

6.6 REPO Connection

Refer to the Liebert Nfinity user manual for information on connecting the REPO.

6.7 Input and Output Wiring



NOTE

Input wiring must be installed using conduit.

208 input voltage jumper—if only the connections for 208 VAC are made between the UPS and the Liebert Nfinity Maintenance Bypass, the 208 input voltage jumper must be installed for proper operation. To install this jumper, place the jumper wire provided in the accessory kit between Pin 1 and Pin 2 on TB4.

To connect the input wiring:

1. Locate the input wiring access (see illustration at right).
2. Remove the knockout and pull the three/four input wires through it, allowing some slack for installation.
3. Secure the conduit to the rear panel of the Liebert Nfinity Maintenance Bypass Cabinet.
4. Input power cables connect to hex terminals on the input terminal block.
5. Insert the ground (earth) wire through the earth lug and tighten it to the proper torque value (120 in-lb). Then connect the wires to the block connections as shown at right. Using a torque wrench, turn the screws clockwise until tightened to the proper torque value (50 in-lb).

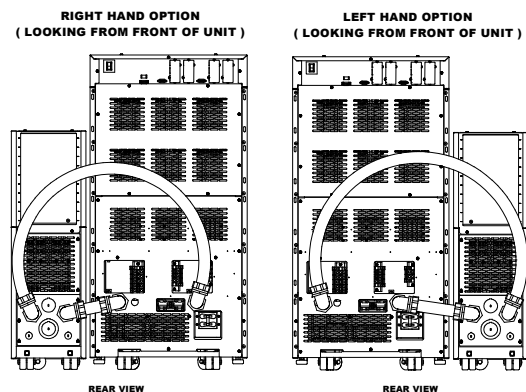
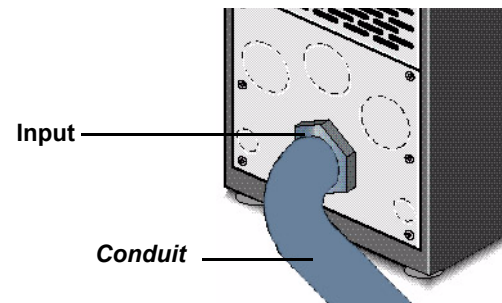

NOTE

The Liebert Nfinity UPS and Liebert Nfinity Maintenance Bypass with transformer contain an isolation transformer that generates a neutral conductor for the connected equipment. The UPS and Maintenance Bypass with transformer are a separately derived source and contain a neutral-to-ground bonding jumper. A grounding electrode conductor (GEC) must be installed in accordance with national and local wiring codes and regulations.

Figure 10 Electrical connections—non-transformer model MBC

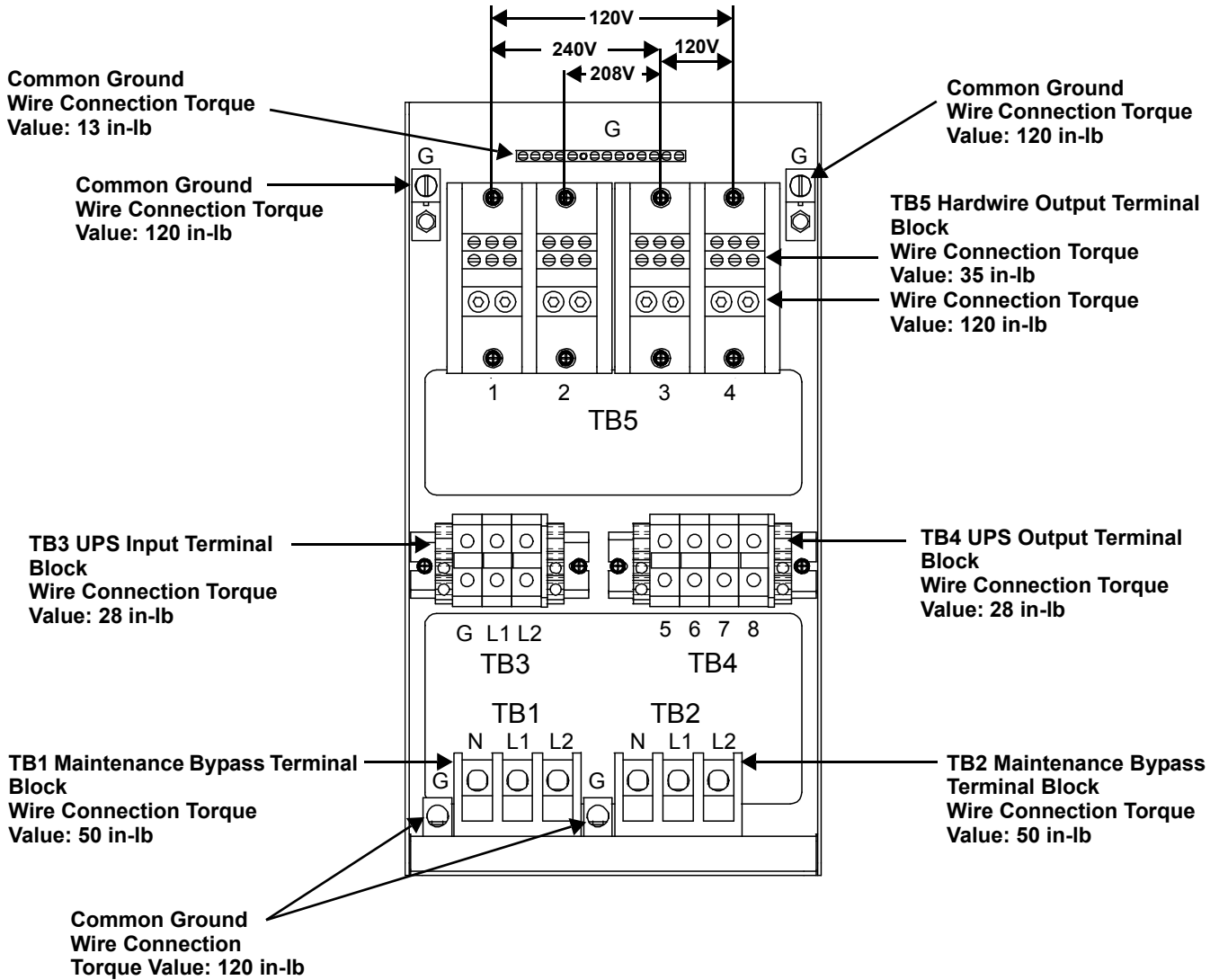
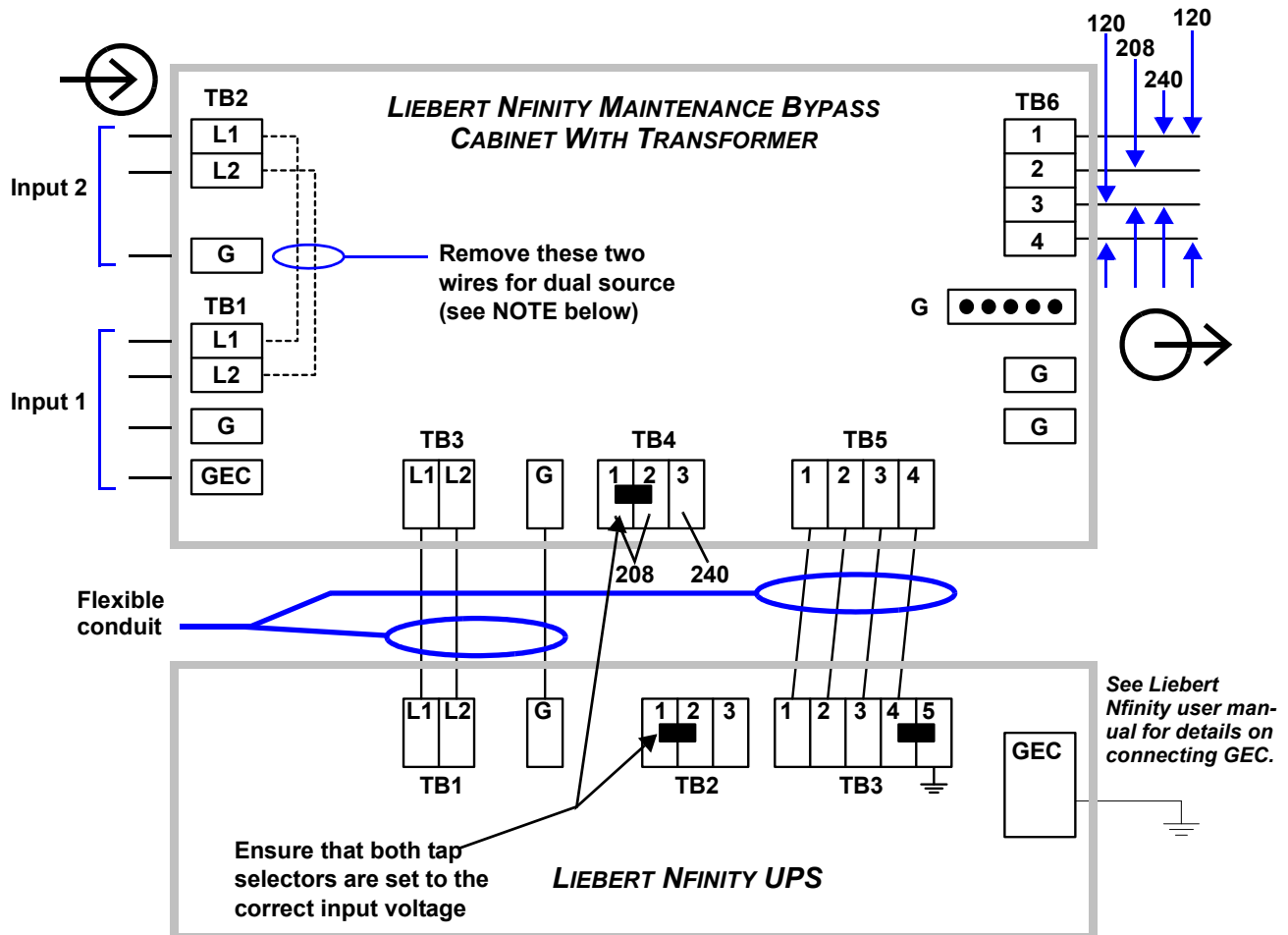
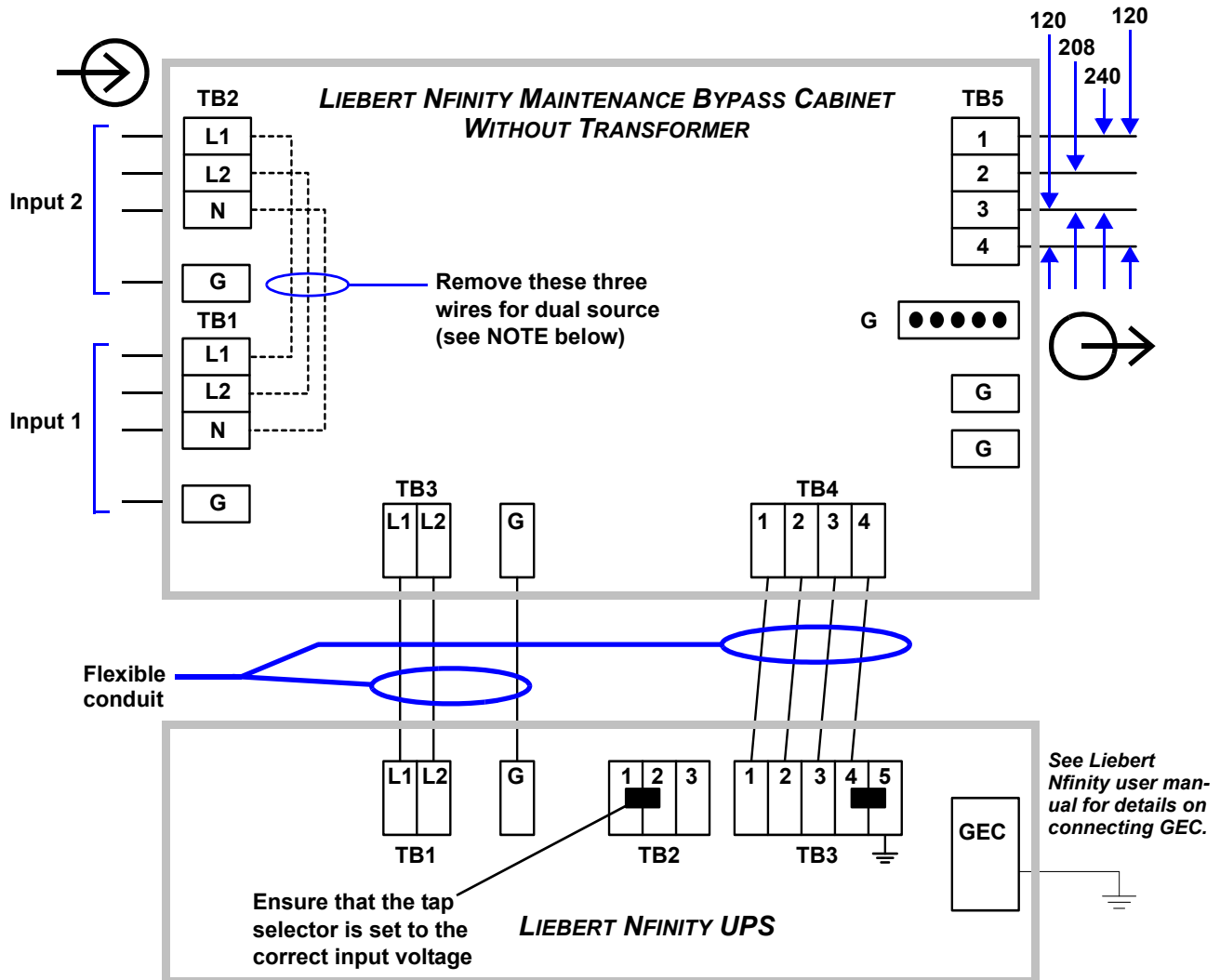

Figure 11 Connecting Liebert Nfinity to Liebert Nfinity Maintenance Bypass with transformer

**NOTE**

1. **SINGLE-SOURCE FEED**—If feeding the Liebert Nfinity Maintenance Bypass Cabinet from a single source, the input connection may be made to either TB1 or TB2.
2. **DUAL-SOURCE FEED**—If feeding the Liebert Nfinity Maintenance Bypass Cabinet from a dual source, the UPS input supply connection must be made to TB1 and the bypass input supply connection must be made to TB2. The jumpers between TB1 and TB2 must be removed.
3. If connected equipment is a combination of 208 VAC and 120 VAC, use a three-phase panel board connected to the output terminal TB6.

Figure 12 Connecting Liebert Nfinity to a Liebert Maintenance Bypass Cabinet without transformer

**NOTE**

1. **SINGLE-SOURCE FEED**—If feeding the Liebert Nfinity Maintenance Bypass Cabinet from a single source, the input connection may be made to either TB1 or TB2.
2. **DUAL-SOURCE FEED**—If feeding the Liebert Nfinity Maintenance Bypass Cabinet from a dual source, the UPS input supply connection must be made to TB1 and the bypass input supply connection must be made to TB2. The jumpers between TB1 and TB2 must be removed.
3. If connected equipment is a combination of 208 VAC and 120 VAC, use a three-phase panel board connected to the output terminal TB5.

7.0 OPERATION

7.1 Start-Up and Initialization

To start up the Liebert Nfinity UPS while it is connected to the Liebert Nfinity Maintenance Bypass:

1. Set the Maintenance Bypass switch (SW1) to the UPS position on the Liebert Nfinity Maintenance Bypass Cabinet.
2. Close the UPS Source Switch (SW2) on the Liebert Nfinity Maintenance Bypass Cabinet.
3. Close the output circuit breaker (CB1) on the Liebert Nfinity Maintenance Bypass Cabinet.
4. Close the input circuit breaker (CB1) on the UPS.
5. On the UPS, close the Control Enable switch (SW2).
6. After the UPS has initialized, turn the UPS output on by pushing the Standby button.

7.2 Shutting Down the UPS

To power down the UPS system:

1. Turn the UPS output Off by pushing the Standby button.
2. Open the Control Enable switch (SW2) on the UPS.
3. Open the input circuit breaker (CB1) on the UPS.
4. Open the UPS Source Switch (SW2) on the Liebert Nfinity Maintenance Bypass Cabinet.
5. Open the output circuit breaker (CB1) on the Liebert Nfinity Maintenance Bypass Cabinet.

7.3 Transferring the System from UPS to Maintenance Bypass Operation

1. Verify that the amber Bypass lamp is illuminated
2. Turn the Bypass Switch (SW1) to the bypass position on the Liebert Nfinity Maintenance Bypass Cabinet. The connected equipment is now powered from the bypass source and **is not protected**.

7.4 Transferring the System from Maintenance Bypass to UPS Operation

1. Close the UPS Source Switch (SW2) on the Liebert Nfinity Maintenance Bypass Cabinet.
2. Close the input circuit breaker (CB1) on the UPS.
3. Close the Control Enable Switch (SW2) on the UPS.
4. Turn the UPS output On by pushing the Standby button on the UPS.
5. Verify that the green UPS lamp is illuminated.
6. Turn the Bypass Switch to the UPS position on the Liebert Nfinity Maintenance Bypass Cabinet.

8.0 MAINTENANCE

8.1 Proper Care

Keeping your Liebert Nfinity Maintenance Bypass Cabinet operating properly is imperative to optimal performance and life of the unit. It is recommended that a certified technician perform preventive and corrective maintenance. Liebert Global Services (LGS) is dedicated to ensuring the highest level of performance and unmatched support for your Liebert Nfinity Maintenance Bypass Cabinet. Contact an LGS representative for services to guarantee maximum reliability and system availability.

8.2 Scheduled Maintenance

Liebert recommends performing the following maintenance at least monthly:

- Check, clean and replace filters.
- Verify that airflow is not obstructed.

Liebert recommends performing the following maintenance annually:

- Verify all power connections.
- Verify that all output distribution modules are operating properly.

8.2.1 Replacing Fan Filters—Transformer Models Only

The Liebert Nfinity Maintenance Bypass Cabinet intake fans contain filters that will need to be replaced or cleaned periodically, depending on the surrounding environment. Check by noting the condition of the two filters. If filters are dirty, replace or wash them. The filters may be taken out of the UPS for replacement or cleaning by removing the plastic cover over the filter frame. Use caution when replacing filters when fans are running.

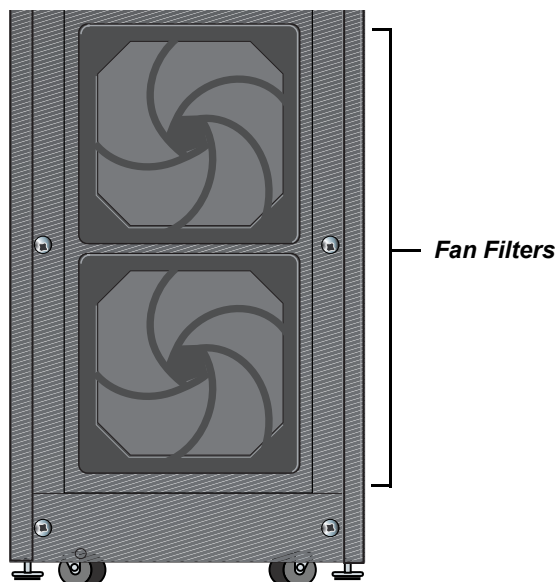

The fan filters are washable and may be reused. To wash these filters, place them under a running faucet (with the dirty side down) to remove dirt and dust. Blot dry with a towel and allow to air-dry before reusing it.

9.0 SPECIFICATIONS

General & Environmental		Rating			
Unit Rating		kVA	Models NMB1x and NMB4x = 18		
			Models NMB5x and NMB8x = 20		
		Amps	Models NMB1x and NMB4x = 100 max		
			Models NMB5x and NMB8x = 125 max		
Safety Standards			UL 1778, c-UL		
Mechanical					
Dimensions		Width	In (mm)	9.5 (241)	
		Depth		26.5 (700)	
		Height		30.4 (775)	
		Weight	lb (kg)	287 (130) transformer model	85 (39) transformerless model
Environmental					
Operating Temperature (max)		F (C)	32° - 104° (0° - 40°)		
Relative Humidity		%	0-95% non-condensing		
Maximum Operating Altitude		Ft (M)	10,000 (3000)		
Input Data					
Nominal Input Voltage		VAC	208 or 240		
Input Frequency (nominal)		Hz	60		
Input Frequency Range		Hz	55-65		
Output Data			208/240	240	208
Output Voltage		VAC	120/120/208/240	120/120/240*	120/120/208*
Transfer Time		msec	<4 msec typical		
Output Frequency		Hz	60		

* Transformerless model requires neutral input

Ensuring The High Availability Of Mission-Critical Data And Applications.

Emerson Network Power, the global leader in enabling business-critical continuity, ensures network resiliency and adaptability through a family of technologies—including Liebert power and cooling technologies—that protect and support business-critical systems. Liebert solutions employ an adaptive architecture that responds to changes in criticality, density and capacity. Enterprises benefit from greater IT system availability, operational flexibility and reduced capital equipment and operating costs.

Technical Support / Service Web Site

www.liebert.com

Monitoring

800-222-5877

Liebert.monitoring@emerson.com

Outside the US: 614-841-6755

Single-Phase UPS

800-222-5877

upstech@emersonnetworkpower.com

Outside the US: 614-841-6755

Three-Phase UPS

800-543-2378

powertech@emersonnetworkpower.com

Environmental Systems

800-543-2778

Outside the United States

614-888-0246

Locations

United States

1050 Dearborn Drive

P.O. Box 29186

Columbus, OH 43229

Europe

Via Leonardo Da Vinci 8

Zona Industriale Tognana

35028 Piove Di Sacco (PD) Italy

+39 049 9719 111

Fax: +39 049 5841 257

Asia

7/F Dah Sing Financial Centre

108 Gloucester Road

Wanchai

Hong Kong

852 2572 2201

Fax: 852 2519 9210

While every precaution has been taken to ensure the accuracy and completeness of this literature, Liebert Corporation assumes no responsibility and disclaims all liability for damages resulting from use of this information or for any errors or omissions.

© 2008 Liebert Corporation

All rights reserved throughout the world. Specifications subject to change without notice.

® Liebert is a registered trademark of Liebert Corporation.

All names referred to are trademarks or registered trademarks of their respective owners.

SL-23960_REV05_03-09

Emerson Network Power.

The global leader in enabling *Business-Critical Continuity*.

■ AC Power

■ Embedded Computing

■ Outside Plant

■ Racks & Integrated Cabinets

■ Connectivity

■ Embedded Power

■ Power Switching & Controls

■ Services

■ DC Power

■ Monitoring

■ Precision Cooling

■ Surge Protection

EmersonNetworkPower.com

Business-Critical Continuity, Emerson Network Power and the Emerson Network Power logo are trademarks and service marks of Emerson Electric Co.

©2008 Emerson Electric Co.