

## SITE PLANNING DATA, SERIES 610, 500-750kVA, MULTI-MODULE SYSTEMS

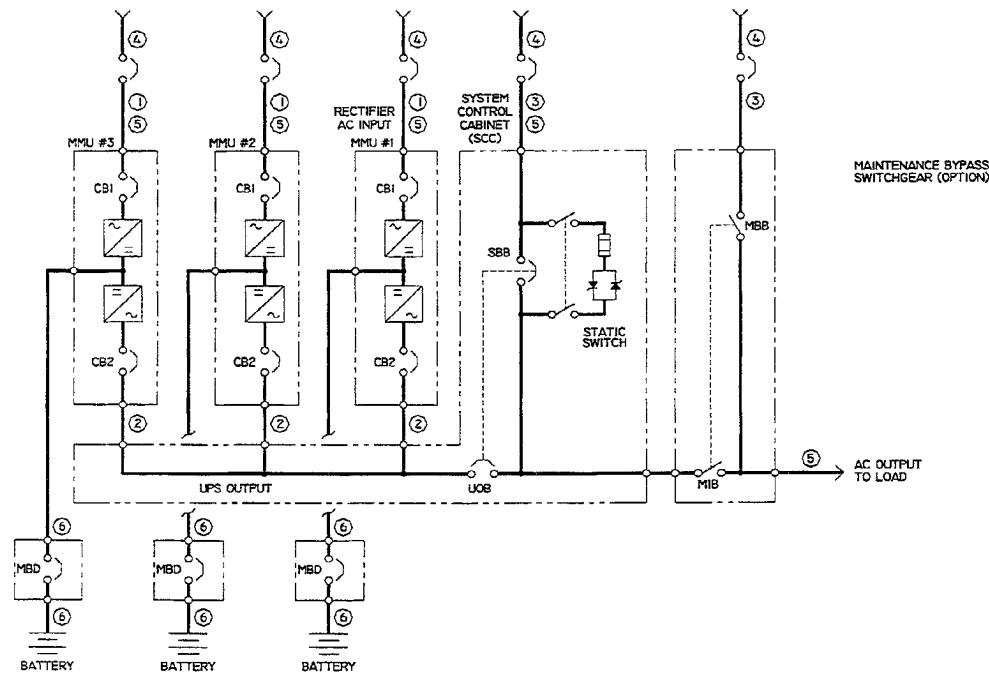

### Notes for Tables 1 - 2

- Nominal rectifier AC input current (considered continuous) is based on full rated output load. Maximum current includes nominal input current and maximum battery recharge current (considered noncontinuous). Continuous and noncontinuous current limits are defined in NEC 100. Maximum input current is controlled by current limit setting which is adjustable 100 to 125% of nominal input current—except 750kVA/675kW, for which the maximum is adjustable 100 to 115% of nominal. Standard factory setting is 115%.
  - Nominal AC output current (considered continuous) is based on full rated output load. Maximum current includes nominal output current and overload current for 10 minutes.
  - Bypass AC input current (considered continuous) is based on full rated output load.
  - Feeder protection (by others in external equipment) for rectifier AC input and bypass AC input is recommended to be provided by separate overcurrent protection devices.
  - UPS output load cables must be run in separate conduit from input cables.
  - Power cable from module DC bus to battery should be sized for a total maximum 2.0 volt line drop (power cable drop plus return cable drop as measured at the module) at maximum discharge current.
  - Grounding conductors to be sized per NEC 250-122. Neutral conductors to be sized for full capacity—per NEC 310-15 (b)(4)—for systems with 4-wire loads and half capacity for systems with 3-wire loads.
- (7 continued)
- NOTE:** A neutral conductor is required from each Multi-Module Unit output to the System Control Cabinet and from each SCC to the Power-Tie™ cabinet, if applicable. See grounding diagrams in the Installation Manual.
- Rectifier AC Input: 3-phase, 3-wire, plus ground
  - AC Output to Load: 3-phase, 3- or 4-wire, plus ground
  - Bypass AC Input to SCC: 3-phase, 4-wire, plus ground (3-wire plus ground in certain circumstances)
  - Module DC Input from Battery: 2-wire (positive and negative), plus ground
  - Module Input to SCC: 3-phase, 4-wire, plus ground
  - All wiring is to be in accordance with National and Local Electrical Codes.
  - Minimum overhead clearance is 2 ft. (0.6m) above the UPS.
  - Top or bottom cable entry through removable access plates. Cut plate to suit conduit size.
  - Control wiring and power cables must be run in separate conduits. Control wiring must be stranded tinned conductors.
  - 7% maximum reflected input harmonic current and 0.92 lagging input power factor at full load with optional input filter.  
4% maximum reflected input harmonic current and 0.92 lagging input power factor at full load with optional 12-pulse rectifier and optional input filter.
  - Dimensions and weights do not include the System Control Cabinet required for Multi-Module Systems.

**Table 1 Site planning data—600V input**

UPS Rating		AC Output Voltage	Options		Rectifier AC Input Current		Inverter Output Current		Required Battery Disconnect Rating (A)	Max. Battery Current at End of Discharge (A)	Max. Heat Dissipation Full Load BTU/h (kWH)	Dimensions	Approx. Weight Unpacked	Floor Loading Concentrated Loading
kVA	kW	VAC	Input Filter	Input Xformer	Nom	Max	Nom	Max				WxDxH: in. (mm)	lb. (kg)	lb./ft. 2 (kg/m <sup>2</sup> )
500	400	600	NO	NO	484	605	481	601	1000	1079	94,900 (27.8)	72x39x78 (1829x991x1981)	6110 (2771)	313 (1528)
500	400	600	YES	NO	449	561	481	601	1000	1079	99,600 (29.2)		6310 (2862)	324 (1582)
500	400	600	NO	YES	490	612	481	601	1000	1079	118,700 (34.8)	96x39x78 (2438x991x1981)	8710 (3951)	335 (1636)
500	400	600	YES	YES	454	567	481	601	1000	1079	123,570 (36.2)		8910 (4042)	343 (1675)
500	450	600	NO	NO	545	681	481	601	1200	1214	106,750 (31.3)	72x39x78 (1829x991x1981)	6130 (2781)	314 (1533)
500	450	600	YES	NO	505	631	481	601	1200	1214	112,050 (32.8)		6330 (2871)	325 (1587)
500	450	600	NO	YES	551	688	481	601	1200	1214	133,550 (39.1)	96x39x78 (2438x991x1981)	9030 (4096)	347 (1694)
500	450	600	YES	YES	510	638	481	601	1200	1214	139,010 (40.7)		9230 (4187)	355 (1733)
625	500	600	NO	NO	602	753	601	752	1400	1349	108,950 (31.9)	108x39x78 (2743x991x1981)	7805 (3540)	300 (1465)
625	500	600	YES	NO	559	699	601	752	1400	1349	118,650 (34.7)		8025 (3640)	309 (1509)
625	500	600	NO	YES	609	761	601	752	1400	1349	128,450 (37.6)	120x39x78 (3048x991x1981)	10485 (4756)	323 (1577)
625	500	600	YES	YES	564	705	601	752	1400	1349	134,400 (39.4)		10705 (4856)	329 (1606)
750	600	600	NO	NO	723	903	722	902	1600	1619	130,700 (38.3)	108x39x78 (2743x991x1981)	8405 (3812)	323 (1577)
750	600	600	YES	NO	671	839	722	902	1600	1619	142,350 (41.7)		8625 (3912)	332 (1621)
750	600	600	NO	YES	730	913	722	902	1600	1619	154,150 (45.1)	120x39x78 (3048x991x1981)	11485 (5210)	353 (1723)
750	600	600	YES	YES	677	846	722	902	1600	1619	161,250 (47.2)		11705 (5309)	360 (1758)
750	675	600	NO	YES	822	945	722	902	1600	1822	173,400 (50.8)		11785 (5346)	363 (1772)
750	675	600	YES	YES	762	876	722	902	1600	1822	181,400 (53.1)		12005 (5445)	369 (1802)
<b>See Notes (p. 1):</b>			13	—	1,4,5,7,8,9,11,12		2,3,5,7,8,9,11,12		6	6,8,9,11,12	—		14	14

Table 2 Site planning data—480V input

UPS Rating		AC Output Voltage	Options		Rectifier AC Input Current		Inverter Output Current		Required Battery Disconnect Rating (A)	Max. Battery Current at End of Discharge (A)	Max. Heat Dissipation Full Load BTU/h (kWH)	Dimensions	Approx. Weight Unpacked	Floor Loading Concentrated Loading
kVA	kW	VAC	Input Filter	Input Xformer	Nom	Max	Nom	Max				WxDxH: in. (mm)	lb. (kg)	lb./ft. 2 (kg/m <sup>2</sup> )
500	400	480	NO	NO	602	753	601	752	1000	1079	87,150 (25.5)	72x39x78 (1829x991x1981)	5710 (2590)	293 (1431)
500	400	480	YES	NO	558	698	601	752	1000	1079	91,790 (26.9)		5910 (2681)	303 (1479)
500	400	480	NO	YES	612	765	601	752	1000	1079	110,700 (32.4)	96x39x78 (2438x991x1981)	8710 (3951)	335 (1636)
500	400	480	YES	YES	567	709	601	752	1000	1079	115,550 (33.8)		8910 (4042)	343 (1675)
500	450	480	NO	NO	677	847	601	752	1200	1214	98,050 (28.7)	72x39x78 (1829x991x1981)	5730 (2599)	294 (1435)
500	450	480	YES	NO	628	785	601	752	1200	1214	103,250 (30.2)		5930 (2690)	304 (1484)
500	450	480	NO	YES	688	861	601	752	1200	1214	124,550 (36.5)	96x39x78 (2438x991x1981)	9030 (4096)	347 (1694)
500	450	480	YES	YES	638	798	601	752	1200	1214	129,950 (38.1)		9230 (4187)	355 (1733)
625	500	480	NO	NO	749	936	752	940	1400	1349	99,300 (29.1)	108x39x78 (2743x991x1981)	7405 (3359)	285 (1391)
625	500	480	YES	NO	694	867	752	940	1400	1349	105,050 (30.8)		7625 (3459)	293 (1431)
625	500	480	NO	YES	757	946	752	940	1400	1349	118,650 (34.7)	120x39x78 (3048x991x1981)	10485 (4756)	323 (1577)
625	500	480	YES	YES	701	877	752	940	1400	1349	124,500 (36.5)		10705 (4856)	329 (1606)
750	600	480	NO	NO	898	1123	902	1128	1600	1619	119,200 (34.9)	108x39x78 (2743x991x1981)	8005 (3631)	308 (1504)
750	600	480	YES	NO	833	1041	902	1128	1600	1619	126,100 (36.9)		8225 (3731)	316 (1543)
750	600	480	NO	YES	908	1135	902	1128	1600	1619	142,350 (41.7)	120x39x78 (3048x991x1981)	11485 (5210)	353 (1723)
750	600	480	YES	YES	842	1052	902	1128	1600	1619	149,400 (43.7)		11705 (5309)	360 (1758)
750	675	480	NO	YES	1022	1175	902	1128	1600	1822	160,150 (46.9)		11785 (5346)	363 (1772)
750	675	480	YES	YES	947	1089	902	1128	1600	1822	168,100 (49.2)		12005 (5445)	369 (1802)
<b>See Notes (p. 1):</b>			13	—	1,4,5,7,8,9,11,12		2,3,5,7,8,9,11,12		6	6,8,9,11,12	—		14	14

## System Control Cabinets

Multi-Module Systems are provided with a System Control Cabinet. Cabinets are available to match load current. **Table 3** shows dimensions and weights for SCCT cabinets.

**Table 3 System Control Cabinet data - SCCT**

Type	Amps	Overall dimensions - WxDxH: in. (mm)	Weight - lb. (kg)
SCCT	560-1200	37x37x78 (940x940x1981)	1000 (454)
SCCT	1600	62x48x78 (1575x1219x1981)	1525 (692)
SCCT	2000	62x48x78 (1575x1219x1981)	2850 (1293)
SCCT	2500-3000	62x60x78 (1575x1524x1981)	3100 (1406)
SCCT	4000	138x60x78 (3505x1524x1981)	5850 (2653)

© 2005 Liebert Corporation  
 All rights reserved throughout the world. Specifications subject to change without notice.

® Liebert and the Liebert logo are registered trademarks of Liebert Corporation.  
 All names referred to are trademarks or registered trademarks of their respective owners.

SL-25146 (1/05) Rev. 1



### Liebert Corporation

1050 Dearborn Drive  
 P.O. Box 29186  
 Columbus, OH 43229

Telephone: 1-800-877-9222  
 Facsimile: 1-614-841-6022  
[www.liebert.com](http://www.liebert.com)

