

Liebert Series 610™ UPS

Installation Manual - 300-450kVA, 60Hz, Three Phase Multi-Module

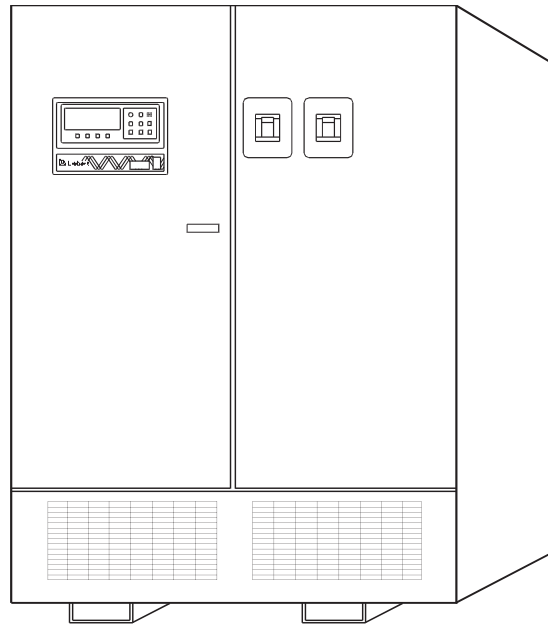

BATTERY CABINET PRECAUTIONS

The following warning applies to all battery cabinets supplied with UPS systems. Additional warnings and cautions applicable to battery cabinets may be found in:

- **Important Safety Instructions**—page 1
- **Section 2.0 - Unloading and Handling**
- **Section 5.0 - Battery Installation**



WARNING

Internal battery strapping must be verified by manufacturer prior to moving a battery cabinet (after initial installation).

- Battery cabinets contain non-spillable batteries.
- Keep units upright.
- Do not stack.
- Do not tilt.

Failure to heed this warning could result in smoke, fire or electric hazard.

Call 1-800-LIEBERT prior to moving battery cabinets (after initial installation).

CONTACTING LIEBERT FOR SUPPORT

To contact Liebert Global Services for information or repair service in the United States, call 1-800-LIEBERT (1-800-543-2378). Liebert Global Services offers a complete range of start-up services, repair services, preventive maintenance plans and service contracts.

For repair or maintenance service outside the 48 contiguous United States, contact Liebert Global Services, if available in your area. For areas not covered by Liebert Global Services, the authorized distributor is responsible for providing qualified, factory-authorized service.

For LGS to assist you promptly, please have the following information available:

Part numbers: _____

Serial numbers: _____

Rating: _____

Date purchased: _____

Date installed: _____

Location: _____

Input voltage/frequency: _____

Output voltage/frequency: _____

Battery reserve time: _____

TABLE OF CONTENTS

BATTERY CABINET PRECAUTIONS	INSIDE FRONT COVER
CONTACTING LIEBERT FOR SUPPORT	INSIDE FRONT COVER
IMPORTANT SAFETY INSTRUCTIONS	1
1.0 INSTALLATION CONSIDERATIONS	3
1.1 Types of System Control Cabinets	5
2.0 UNLOADING AND HANDLING	6
3.0 INSPECTIONS	7
3.1 External Inspections	7
3.2 Internal Inspections and Shipping Material Removal	7
4.0 EQUIPMENT LOCATION	8
5.0 BATTERY INSTALLATION	9
5.1 Battery Safety Precautions	9
5.2 Battery Safety Precautions in French Per CSA Requirements	10
5.3 Battery Cabinets	11
5.4 Open-Rack Batteries	12
6.0 OPTIONAL TRANSFORMER CABINET	13
7.0 CONFIGURING YOUR NEUTRAL AND GROUND CONNECTIONS	14
7.1 Preferred Grounding Configuration, Wye-Connected Service	15
7.2 Alternate Grounding Configuration, Wye-Connected Service	16
7.3 Preferred Grounding Configuration With Isolated Bypass	17
7.4 Alternate Grounding Configuration, Non-Isolated	18
7.5 Grounding Configuration, Corner-Grounded Delta or Impedance-Grounded Wye	19
7.6 Preferred Grounding Configuration, Battery Systems	21
8.0 WIRING CONSIDERATIONS	22
8.1 Power Wiring	23
8.2 Control Wiring	25
8.3 Battery Wiring	26
9.0 WIRING CONNECTIONS	27
9.1 Specific Connections	27
10.0 WIRING INSPECTION	29
11.0 INSTALLATION DRAWINGS	32
APPENDIX A - SITE PLANNING DATA, SERIES 610, 300-450KVA, MULTI-MODULE SYSTEMS	83

FIGURES

Figure 1	Multi-Module 300 to 450kVA UPS.	4
Figure 2	UPS Multi-Module Unit block diagram	5
Figure 3	System Control Cabinets	5
Figure 4	Preferred grounding configuration, wye-connected service	15
Figure 5	Alternate grounding configuration, wye-connected service	16
Figure 6	Preferred grounding configuration with isolated bypass	17
Figure 7	Alternate grounding configuration, non-isolated	18
Figure 8	Preferred grounding configuration, corner-grounded delta or impedance-grounded wye	19
Figure 9	Preferred grounding configuration, impedance-grounded wye	20
Figure 10	Preferred grounding configuration, battery systems	21
Figure 11	Power single line diagrams, Multi-Module configurations*	24
Figure 12	One-line diagram, two-module parallel system with two-breaker maintenance bypass	32
Figure 13	One-line diagram, four-module parallel system with three-breaker maintenance bypass	33
Figure 14	Outline drawing, 300kVA Multi-Module UPS	34
Figure 15	Terminal details, 300kVA Multi-Module UPS	35
Figure 16	Outline drawing, 300kVA Multi-Module UPS with input ISO transformer cabinet (optional)	36
Figure 17	Terminal details, 300kVA Multi-Module UPS with input ISO transformer cabinet (optional)	37
Figure 18	Outline drawing, 400kVA Multi-Module UPS	38
Figure 19	Terminal details, 400kVA Multi-Module UPS	39
Figure 20	Outline drawing, 450kVA Multi-Module UPS, 480V input, 480V output	40
Figure 21	Terminal details, 450kVA Multi-Module UPS, 480V input, 480/277V output	41
Figure 22	Outline drawing, 400 & 450kVA Multi-Module UPS with input ISO transformer cabinet (optional)	42
Figure 23	Terminal details, 400 & 450kVA Multi-Module UPS with input ISO transformer cabinet (optional)	43
Figure 24	Base mounting patterns, 300-450kVA modules	44
Figure 25	Line-up detail, 300-450kVA Multi-Module System with input isolation transformer cabinet.	45
Figure 26	Battery power pack system	46
Figure 27	Battery power pack, Size A.	47
Figure 28	Line-up detail, 300-500kVA Single- or Multi-Module System with battery cabinets.	48
Figure 29	Outline drawing, System Control Cabinet (SCCT), 200-1200A	49
Figure 30	Base mounting patterns, System Control Cabinet (SCCT), 200-1200A	50
Figure 31	Outline drawing, System Control Cabinet (SCCT), 1600-2000A	51
Figure 32	Base mounting patterns, System Control Cabinet (SCCT), 1600-2000A	52
Figure 33	Outline drawing, System Control Cabinet (SCCT), 2500-3000A	53
Figure 34	Base mounting patterns, System Control Cabinet (SCCT), 2500-3000A	54
Figure 35	Outline drawing, System Control Cabinet (SCCT), 4000A	55
Figure 36	Base mounting patterns, System Control Cabinet (SCCT), 4000A	56
Figure 37	Control connection location diagram, Multi-Module System, 300-500kVA.	57
Figure 38	Control connection location diagram, SCCT	58
Figure 39	Control wiring, external interconnect diagram, Multi-Module System.	59
Figure 40	Control wire list, external interconnections, standard wiring, Multi-Module System, UPS module, Cable Group #1.	60
Figure 41	Control wire list, external interconnections, standard wiring, Multi-Module System, System Control Cabinet, Part 1 of 3, Cable Groups #2 & #3	61
Figure 42	Control wire list, external interconnections, standard wiring, Multi-Module System, System Control Cabinet, Part 2 of 3, Cable Groups #5 & #6	62
Figure 43	Control wire list, external interconnections, standard wiring, Multi-Module System, System Control Cabinet, Part 3 of 3, Cable Group #8	63

Figure 44	Control wire list, external interconnections, Multi-Module System, remote status panel option, Cable Group #4	64
Figure 45	Control wire list, external interconnections, Multi-Module System (SCC with momentary duty static switch), customer alarm interface option, Cable Group #9	65
Figure 46	Control wire list, external interconnections, Multi-Module System, alarm status contacts option, Cable Group #14.	66
Figure 47	Control wire list, external interconnections, Multi-Module System, battery temperature sensor option, Cable Group #15	67
Figure 48	Control wire list, external interconnections, Multi-Module System, maintenance bypass interlock option, Cable Group #7	68
Figure 49	Control wire list, external interconnections, Multi-Module System, SNMP interface option, Cable Group #26	69
Figure 50	Control wire list, external interconnections, Multi-Module System, Module 1/SCC, Cable Groups #20 & #21	70
Figure 51	Control wire list, external interconnections, Multi-Module System, Module 2/SCC, Cable Groups #20 & #21	71
Figure 52	Control wire list, external interconnections, Multi-Module System, Module 3/SCC, Cable Groups #20 & #21	72
Figure 53	Control wire list, external interconnections, Multi-Module System, Module 4/SCC, Cable Groups #20 & #21	73
Figure 54	Control wire list, external interconnections, Multi-Module System, Module 5/SCC, Cable Groups #20 & #21	74
Figure 55	Control wire list, external interconnections, Multi-Module System, Module 6/SCC, Cable Groups #20 & #21	75
Figure 56	Outline drawing, single-breaker module battery disconnect, 175-250A, 600VDC circuit breaker	76
Figure 57	Outline drawing, dual-breaker module battery disconnect, 175-250A, 600VDC circuit breaker	77
Figure 58	Outline drawing, single-breaker module battery disconnect, 300, 450, 600, 800, 1000, 1200A	78
Figure 59	Outline drawing, dual-breaker module battery disconnect, 300 & 450A	79
Figure 60	Outline drawing, dual-breaker module battery disconnect, 600, 800, 1000, 1200A	80
Figure 61	Outline drawing, remote status panel, surface mount	81

TABLES

Table 1	Abbreviations for circuit breakers	25
Table 2	Power wiring terminals, factory supplied	29
Table 3	Torque specifications	29
Table 4	Field-supplied lugs	30
Table 5	Table 310-16, National Electrical Code (Reprint)	31
Table 6	Site planning data—600V input.	84
Table 7	Site planning data—480V input.	85
Table 8	System Control Cabinet data - SCCT	86
Table 9	Site planning data—208V input.	86

IMPORTANT SAFETY INSTRUCTIONS

SAVE THESE INSTRUCTIONS

This manual contains important instructions that should be followed during installation of your Series 610 UPS and batteries.



WARNING

Exercise extreme care when handling UPS cabinets to avoid equipment damage or injury to personnel. The UPS module weight ranges from 4150 to 8320 lbs. (1882 to 3774kg), including input transformer. The battery cabinets weigh from 3150 to 5400 lbs. (1429 to 2449kg).

Locate center of gravity symbols  and determine unit weight before handling each cabinet. Test lift and balance the cabinets before transporting. Maintain minimum tilt from vertical at all times.

Slots at the base of the modules and battery cabinets are intended for forklift use. Base slots will support the unit only if the forks are completely beneath the unit.

System Control Cabinets (SCCs) have holes intended for rigging bars or chains. Prevent chains or cables from contacting cabinet by using spreader bar and adequate padding.

Follow all battery safety precautions when installing, charging or servicing batteries. In addition to the hazard of electric shock, gas produced by batteries can be explosive and sulfuric acid can cause severe burns.

In case of fire involving electrical equipment, use only carbon dioxide fire extinguishers or those approved for use in fighting electrical fires.

Extreme caution is required when performing maintenance.

Be constantly aware that the UPS system contains high DC as well as AC voltages.

Check for voltage with both AC and DC voltmeters prior to making contact.

Read this manual thoroughly, paying special attention to the sections that apply to your installation, before working with the UPS. **Retain this manual for use by installing personnel.**



WARNING

Under typical operation and with all UPS doors closed, only normal safety precautions are necessary. The area around the UPS system should be kept free of puddles of water, excess moisture and debris.

Special safety precautions are required for procedures involving handling, installation and maintenance of the UPS system and the battery. Observe all safety precautions in this manual before handling or installing the UPS system. Observe all precautions in the Operation and Maintenance Manual, before as well as during performance of all maintenance procedures. Observe all battery safety precautions before working on or near the battery.

This equipment contains several circuits that are energized with high voltage. Only test equipment designed for troubleshooting should be used. This is particularly true for oscilloscopes. Always check with an AC and DC voltmeter to ensure safety before making contact or using tools. Even when the power is turned Off, dangerously high potential electric charges may exist at the capacitor banks and at the batteries.

All power and control wiring should be installed by a qualified electrician. All power and control wiring must comply with the NEC and applicable local codes.

ONLY qualified service personnel should perform maintenance on the UPS system. When performing maintenance with any part of the equipment under power, service personnel and test equipment should be standing on rubber mats. The service personnel should wear insulating shoes for isolation from direct contact with the floor (earth ground).

One person should never work alone, even if all power is removed from the equipment. A second person should be standing by to assist and summon help in case an accident should occur.



CAUTION

This unit complies with the limits for a Class A digital device, pursuant to Part 15 Subpart J of the FCC rules and EN550022. These limits provide reasonable protection against harmful interference in a commercial environment. This unit generates, uses and radiates radio frequency energy and, if not installed and used in accordance with this instruction manual, may cause harmful interference to radio communications. Operation of this unit in a residential area may cause harmful interference that the user must correct at his own expense.



NOTE

Materials sold hereunder cannot be used in the patient vicinity (i.e., cannot be used where UL 60601-1, cUL 60601-1 or IEC 60601-1 is required). Medical Applications such as invasive procedures and electrical life support equipment are subject to additional terms and conditions.

1.0 INSTALLATION CONSIDERATIONS

Install your Series 610 UPS in accordance with the submittal drawing package and the following procedures.

A Liebert authorized representative must perform the initial system check-out and start-up to ensure proper system operation. Equipment warranties will be voided unless system start-up is performed by a Liebert authorized representative. Contact your local Liebert sales representative or Liebert Global Services at 1-800-LIEBERT to arrange for system start-up.



CAUTION

Read this manual thoroughly before attempting to wire or operate the unit. Improper installation is the most significant cause of UPS start-up problems.

Do not install this equipment near gas or electric heaters. It is preferable to install the UPS in a restricted location to prevent access by unauthorized personnel.

1. Proper planning will speed unloading, location and connection of the UPS. Refer to **Figures 14** through **61** and **Appendix A**.
2. Be certain that the floor at the final equipment location and along the route (inside the facility) to the installation site can support the cabinet weight and the weight of any moving equipment. The modules weigh from 4150 to 8320 lbs. (1882 to 3774kg). The battery cabinets weigh from 3150 to 5400 lbs. (1429 to 2449kg). The System Control Cabinets weigh from 1000 to 5850 lbs. (454 to 2653kg). Refer to **Appendix A**. For switchgear weights, refer to your submittal package.



WARNING

Locate center of gravity symbols  and determine unit weight before handling cabinet.

3. Plan the route to ensure that the unit can move through all aisleways and doorways and around corners without risking damage. If the modules and batteries must be moved by elevator, check the size of the door openings and the weight-carrying capacity of the elevator.
4. Refer to information later in this manual regarding the optional battery cabinets and Transformer Cabinets. **Observe all battery safety precautions when working on or near the battery.**
5. Use the shortest output distribution cable runs possible, consistent with logical equipment arrangements and with allowances for future additions if planned.
6. Recommended ambient operating temperature is 77°F (25°C). Relative humidity must be less than 95%, non-condensing. Note that room ventilation is necessary, but air conditioning may not be required. Maximum ambient operating temperature is 104°F (40°C) without derating. The batteries should not exceed 77°F (25°C). At elevations above 4000 ft. (1219m), temperature derating may be required for full power output—consult your Liebert sales representative or call 1-800-LIEBERT.
7. Even though your Liebert UPS unit is at least 92-94% efficient, the heat output is substantial. For more specific information, see **Appendix A**. Be sure environmental conditioning systems can accommodate this BTU load, even during utility outages.
8. The installer should attempt to balance the load between the three output phases. The UPS will operate safely with an unbalanced load, but will give optimum performance if the three output phases are loaded within 20 percent of each other.
9. During normal UPS operations, short-term overload current demand from the bypass source may reach 10x the UPS output current rating. This overload current demand may be caused by the magnetizing inrush current of one or more downstream transformers or faults on downstream branch circuits. The instantaneous trip point(s) of the upstream bypass feeder breaker(s) must be set to support these temporary overloads. The magnitude of short-term overload bypass current demand is typically six to eight times the UPS current rating, but must be determined by analysis on a per-site basis. This analysis, generally known as an End-to-End Fault Coordination Study, must be done by a Registered Professional Engineer experienced in this activity and familiar with local codes and related requirements.



NOTE

While Liebert can provide typical guidelines, the responsibility for the proper breaker trip settings outside of the Liebert-manufactured UPS equipment resides with the owner. Contact Liebert Global Services at 1-800-LIEBERT for further details.

10. A breaker coordination study should be performed to ensure proper handling of fault currents.



NOTE

The instantaneous trip setting of the breaker feeding the SCC bypass input should be high enough to accommodate short-duration overloads. The bypass static switch inside the SCC can draw up to 10 times the system's rated current for up to three cycles.

Figure 1 Multi-Module 300 to 450kVA UPS

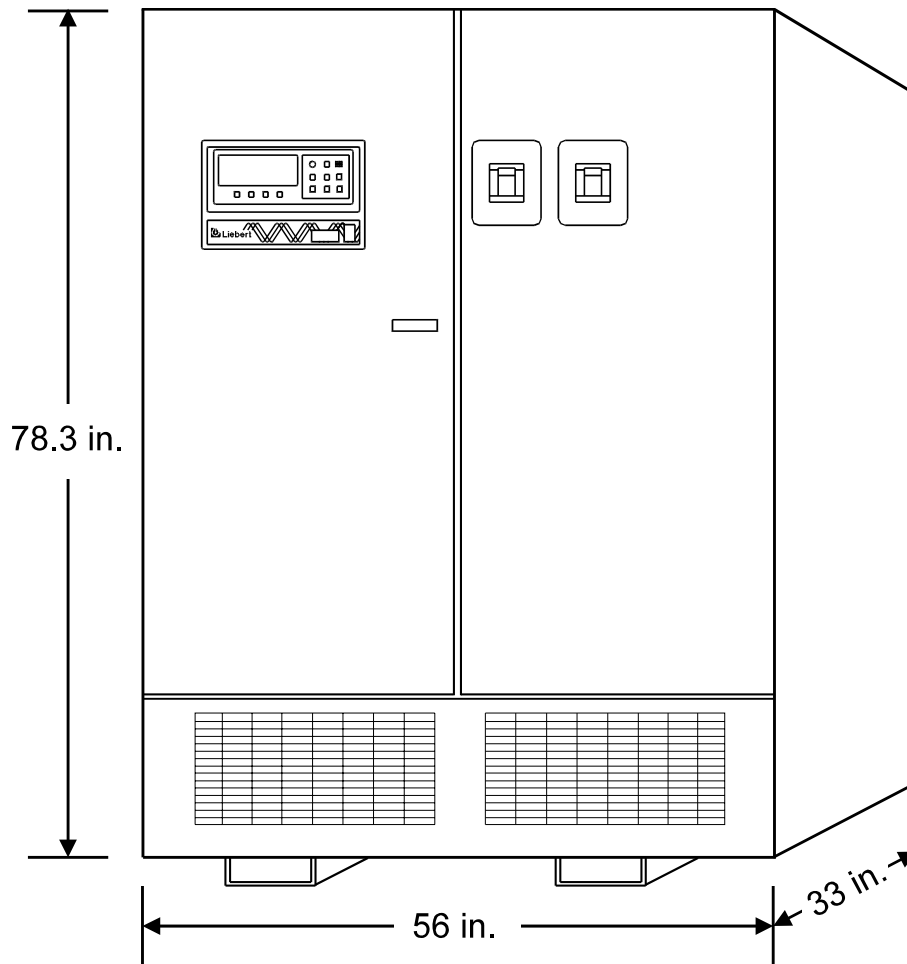
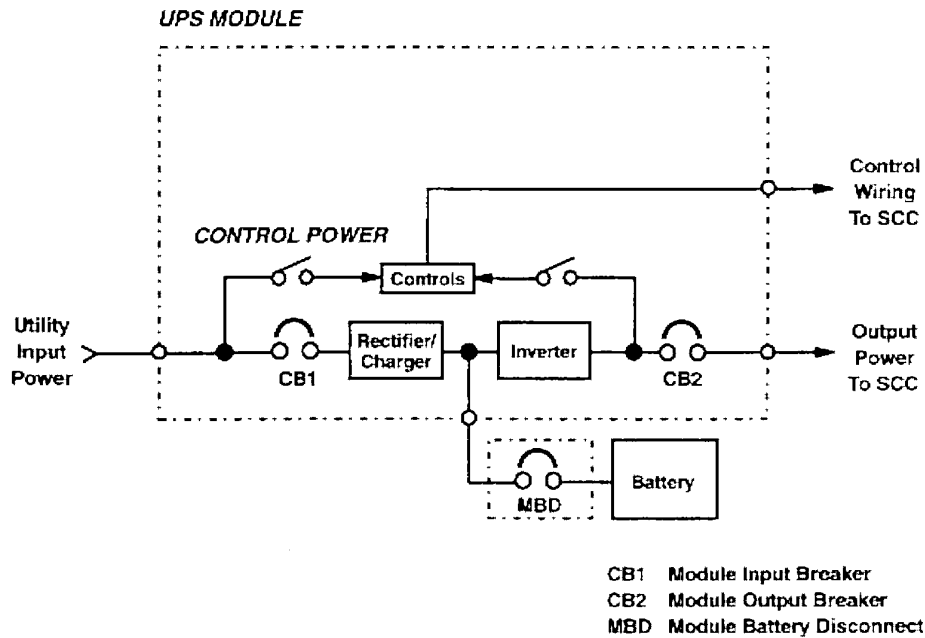

Figure 2 UPS Multi-Module Unit block diagram



1.1 Types of System Control Cabinets

1. **SCCT** is a stand-alone cabinet containing system control logic for up to six UPS modules, static bypass switch, manually operated disconnects for the static bypass switch, and two motor-operated system breakers. The SCCT is painted the same color as the Liebert UPS, but does not match the sheet metal style of the UPS. For SCCT dimensions, refer to **Table 9**.
2. **SCCI** has the system control logic, circuit breakers and static bypass switch integrated into a switchboard cabinet manufactured by others.
3. **SCCC** is an integrated configuration like the SCCT with the static bypass switch rated for continuous duty.

Figure 3 System Control Cabinets

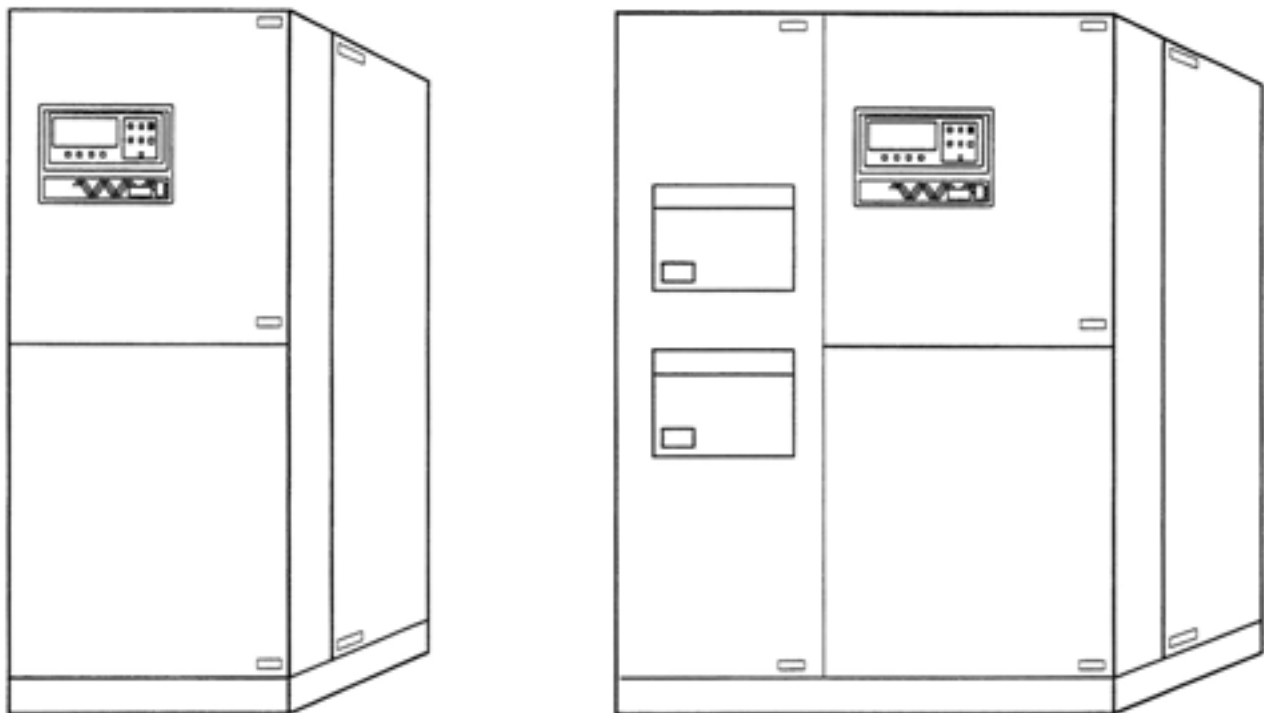

2.0 UNLOADING AND HANDLING

UPS modules are shipped in one cabinet to allow ease of handling. Because the weight distribution in the cabinet is uneven, use extreme care during handling and transport. Your installation may also include battery cabinets and a System Control Cabinet.

**NOTE**

Integrated SCC/Switchgear will be shipped in sections and require proper match up of sections, as identified by labels and drawings.

**WARNING**

Exercise extreme care when handling UPS cabinets to avoid equipment damage or injury to personnel. The UPS module weight ranges from 4150 to 7920 lbs. (1882 to 3592kg). Battery cabinets weigh from 3060 to 5300 lbs. (1388 to 2404kg).

Locate center of gravity symbols before handling cabinet. Test lift and balance the cabinet before transporting. Maintain minimum tilt from vertical at all times.

Slots at the base of the modules and battery cabinets are intended for forklift use. Base slots will support the unit only if the forks are completely beneath the unit.

System Control Cabinets (SCCs)/Switchgear have holes intended for rigging bars or chains (see your submittal package for switchgear drawings). Prevent chains or cables from contacting cabinet by using spreader bar and adequate padding.

To reduce the possibility of shipping damage, cabinets are shored with 2-by-4 bracing, secured with screw-type nails. This shoring must be carefully removed prior to unloading.

**CAUTION**

Extreme care is necessary when removing shoring braces. Do not strike cabinet with hammers or other tools.

3.0 INSPECTIONS

3.1 External Inspections

1. While the UPS system is still on the truck, inspect the equipment and shipping container(s) for any signs of damage or mishandling. Do not attempt to install the system if damage is apparent. If any damage is noted, file a damage claim with the shipping agency within 24 hours and contact Liebert Global Services at 1-800-LIEBERT to inform them of the damage claim and the condition of the equipment.
2. Compare the contents of the shipment with the bill of lading. Report any missing items to the carrier and to Liebert Global Services immediately.
3. Remove equipment from truck using appropriate handling precautions and equipment.
4. Locate cabinet keys. Depending upon equipment type, the keys will either reside in a plastic bag marked "Packing slip enclosed" on a front door of the cabinet, or be taped to a circuit breaker handle protruding through the front of the cabinet.

3.2 Internal Inspections and Shipping Material Removal

1. Verify that all items have been received.
2. If spare parts were ordered, verify arrival.
3. Open doors and remove cabinet panels to check for shipping damage to internal components.
4. Check for loose connections or unsecured components in the cabinet(s).
5. Check for installation of circuit breaker line safety shields. There should be no exposed circuit breaker terminals when the cabinet doors are opened.
6. Check for any unsafe condition that may be a potential safety hazard.
7. UPS modules are shipped with internally mounted shipping brackets. The shipping brackets (painted orange) must be removed from the rear (remove rear panels). The installer must remove the orange shipping brackets before final equipment placement, particularly if rear access will be restricted.



CAUTION

- Failure to remove orange shipping brackets from transformers may cause restricted airflow within the UPS. This could cause overheating or reduction of UPS capacity. In some cases, it could cause damage to the UPS module, and such damage would not be covered under the factory warranty. If you foresee a situation where the UPS will be relocated in the near future, the brackets should be removed and stored elsewhere until they are needed.
8. Check the nameplate/ratings label on the inside of the Module and SCC control section doors to verify that the model numbers correspond with those specified. Record the model numbers and serial numbers in the front of this installation manual. A record of this information is necessary should servicing be required.

4.0 EQUIPMENT LOCATION

1. Handle cabinet(s) in accordance with the safety precautions in this manual, especially in these sections:

- **Battery Cabinet Precautions**—inside front cover
- **Important Safety Instructions**—page 1
- **2.0 - Unloading and Handling**—page 6
- **5.0 - Battery Installation**—page 9

Use a suitable material handling device to move the cabinet to its final location. Exercise extreme care because of the uneven weight distribution. Carefully lower the cabinet to the floor.

2. Verify that the UPS system is installed in a clean, cool and dry location.
3. Installation and serviceability will be easier if adequate access is provided on all sides of the equipment, but only front access is required.
 - a. Verify that there is adequate clearance to open cabinet doors—4 ft. (1.2m) is recommended. NEC requires sufficient clearance in front of the equipment to fully open all doors without restriction. See drawings and local codes. SCCT requires front and rear or one-side access for installation and maintenance.
 - b. Verify that there is adequate area in front of circuit breakers to perform maintenance. Check installation drawings for location of breakers. Check with local codes.
 - c. Verify that there is adequate clearance above all cabinets to allow exhaust air to flow without restriction. The minimum clearance is 2 ft. (0.6m), unobstructed by conduit or any other items. Liebert recommends against using upflow air conditioning systems or any system that blows air down onto the top of the modules.
4. Align the UPS cabinet, battery cabinets (if used) and optional transformer and maintenance bypass cabinets, as shown in the Line-Up Detail drawings (**Figures 25 and 28**) and your submittal package.
5. Connect the cabinets, internal cables and busbars, if applicable. Internal control connections should be left disconnected for later installation by Liebert LGS Customer Engineers.

5.0 BATTERY INSTALLATION

5.1 Battery Safety Precautions

Servicing of batteries should be performed or supervised by personnel knowledgeable of batteries and the required precautions. Keep unauthorized personnel away from batteries.

When replacing batteries, use the same number and type of batteries.



CAUTION

Lead-acid batteries contain hazardous materials. Batteries must be handled, transported and recycled or discarded in accordance with federal, state and local regulations. Because lead is a toxic substance, lead-acid batteries must be recycled rather than discarded.

Do not open or mutilate the battery or batteries. Released electrolyte is harmful to the skin and eyes. It is toxic. Do not dispose of battery or batteries in a fire. The battery may explode.

Do not install any batteries that are cracked, leaking or show other signs of damage. Contact Liebert Global Services or your local Liebert representative.

A battery can present a risk of electrical shock and high short circuit current. The following precautions should be observed when working on batteries:

- Remove watches, rings and other metal objects.
- Use tools with insulated handles.
- Wear rubber gloves and boots.
- Do not lay tools or metal parts on top of batteries.
- Disconnect charging source prior to connecting or disconnecting battery terminals.
- Determine if battery is inadvertently grounded. If inadvertently grounded, remove source of ground. Contact with any part of a grounded battery can result in electrical shock. The likelihood of such shock will be reduced if such grounds are removed during installation and maintenance.

Lead-acid batteries can present a risk of fire because they generate hydrogen gas. The following procedures should be followed:

- DO NOT SMOKE when near batteries.
- DO NOT cause flame or spark in battery area.
- Discharge static electricity from body before touching batteries by first touching a grounded metal surface.
- After replacing battery jars in a battery cabinet, replace the retaining straps that hold the jars in place on the shelves. This will limit accidental movement of the jars and connectors should the cabinet ever need to be repositioned or relocated. Regular maintenance of the battery module is an absolute necessity. Periodic inspections of battery and terminal voltages, specific gravity and connection resistance should be made. Strictly follow the procedures outlined in the battery manufacturer's manual, available on the manufacturer's Web site.

5.2 Battery Safety Precautions in French Per CSA Requirements

Instructions Importantes Concernant La Sécurité Conserver Ces Instructions



AVERTISSEMENT

Respecter toutes les consignes de sécurité applicables à l'installation, le chargement ou l'entretien des batteries. En plus du danger de chocs électriques, le gaz produit par les batteries peut exploser dégageant de l'acide sulfurique qui peut entraîner de très graves brûlures.

Toute opération d'entretien/réparation des batteries doit être exécutée ou supervisée par un personnel qualifié dans le domaine et en prenant toutes les précautions nécessaires. Tenir le personnel non autorisé à l'écart des batteries.



ATTENTION

Les batteries acide-plomb contiennent des substances toxiques dangereuses. Les batteries doivent être manipulées, transportées et recyclées ou jetées conformément à la réglementation en vigueur aux niveaux national et local. Le plomb étant toxique, les batteries acide-plomb doivent être recyclées et non jetées.

Ne pas ouvrir ni endommager la ou les batteries. Les électrolytes diffusés sont dangereux pour la peau et les yeux. Ils sont toxiques. Ne pas jeter la ou les batteries dans le feu. Risque d'explosion.

Ne jamais installer de batteries avec des cellules fissurées ou endommagées. Contacter Liebert Global Services ou le représentant agréé Liebert local.

Une batterie peut poser un risque de choc électrique et de courant élevé provoqué par un court-circuit. Respecter les précautions suivantes lors de travaux sur les batteries:

- Enlever montres, bagues ou autres objets métalliques.
- Utiliser des outils dont les poignées sont isolées.
- Porter des gants et des bottes en caoutchouc.
- Ne pas poser d'outils ou d'objets métalliques sur les batteries.
- Déconnecter la source de chargement avant de connecter ou de déconnecter les bornes de batterie.
- Vérifier que la batterie n'a pas été mise à la masse par inadvertance. Si elle est mise à la masse, éliminer la source de masse. Tout contact avec des composants de batterie mise à la masse peut entraîner un choc électrique. Éliminer le risque de chocs électriques potentiels en retirant les sources de masse avant l'installation et la maintenance.

Les batteries acide-plomb peuvent représenter un risque d'incendie puisqu'elles génèrent de l'hydrogène. Respecter les procédures suivantes:

- NE PAS FUMER près des batteries.
- NE PAS générer de flammes ou d'étincelles près des batteries.
- Éliminer l'électricité statique du corps avant de manipuler les batteries en touchant d'abord une surface métallique mise à la terre.

L'électrolyte est un acide sulfurique dilué qui est dangereux au contact de la peau et des yeux. Ce produit est corrosif et aussi conducteur électrique. Les procédures suivantes devront être observées:

- Porter toujours des vêtements protecteurs ainsi que des lunettes de protection pour les yeux.
- Si l'électrolyte entre en contact avec la peau, nettoyer immédiatement en rincant avec de l'eau.
- Si l'électrolyte entre en contact avec les yeux, arroser immédiatement et généreusement avec de l'eau. Demander pour de l'aide médicale.
- Lorsque l'électrolyte est renversée, la surface affectée devrait être nettoyée en utilisant un agent neutralisant adéquat. Une pratique courante est d'utiliser un mélange d'approximativement une livre (500 grammes) de bicarbonate de soude dans approximativement un gallon (4 litres) d'eau. Le mélange de bicarbonate de soude devra être ajouté jusqu'à ce qu'il n'y ait plus apparence de réaction (mousse). Le liquide résiduel devra être nettoyé à l'eau et la surface concernée devra être asséchée.

5.3 Battery Cabinets

Optional battery cabinets are available from Liebert and other qualified vendors. Consult your submittal package for details.

Several models of optional battery cabinets with varying run times are available. Each model is 78" (1981mm) high and has forklift slots. Refer to **Figures 26** through **28**. The battery cabinet cells range from 90 to 150 ampere-hours. The same model battery cabinet may be paralleled in multiple cabinet strings for additional capacity. Battery capacity (in minutes) at your installation will depend on cabinet model, number of cabinets and amount of critical load on the UPS.



NOTE

Battery cabinets are 33 in. (838mm) deep, compared to 35 in. (889mm) deep for the 300-450kVA UPS modules. They may be installed adjacent to the UPS module, but will not be an exact bolt-up match, as would be the case with 150-225kVA modules.

1. **Handling.** The battery cabinet weighs from 3060 to 5300 lbs. (1388 to 2404kg). Forklift slots are provided for ease of handling.
2. **Cabinet Inspection.** Remove all panels and visually inspect the batteries, bus connections, and cabinet for any damage. If any foam blocks were placed between shelves to restrain movement during shipment, remove them now. **Exercise caution—voltage is present within the battery cabinet even before installation.** If there are signs of damage, do not proceed. Call Liebert Global Services at 1-800-LIEBERT.
3. **Battery Storage.** The batteries used in the battery cabinet retain their charge well. The batteries can be stored indoors in a temperature-controlled environment, for up to six months without any appreciable deterioration. Self-discharge rate of the batteries is approximately 3% per month when the batteries are stored in temperatures of 59°F to 77°F (15-25°C). If the battery cabinet must be stored for longer than six months, contact Liebert Global Services. The battery cabinet should never be stored outdoors or on a loading dock.
4. **Installation.** Battery cabinets can be located conveniently next to each UPS module. The front-access-only-design eliminates side and rear service clearance requirements.
5. **Reinstallation.** If at any time it becomes necessary to move the battery cabinet to another location, contact Liebert Global Services to inspect the internal battery hold-down straps.
6. **Environment.** Locate the battery cabinet in a clean, dry environment. Recommended temperature range for optimum performance and lifetime is 68°F to 77°F (20-25°C).
7. **Service Clearance.** Allow front access to the battery cabinet at all times for maintenance and servicing. Electrical codes require that the battery cabinet be installed with no less than 3 ft. (1m) of clearance at the front of the cabinet when operating. Side and rear panels do not require service clearance.
8. **Side Panels.** To connect battery cabinets together, remove the protective side panels by removing the retaining screws that hold the side panels in place.
9. **Cables.** Multiple battery cabinets may be bolted together in a daisy-chain configuration. Cables for this setup may be run between paralleled battery cabinets through cutouts in the top of the cabinets, eliminating the need for external conduit runs. **Route cables before moving cabinets into final position for bolting together.** Low voltage control wiring must be kept separate from the power wiring. Remove top panels for access, if required. No top or bottom entry cables are required, except for remotely located cabinets, which require conduits. The final connections, including power and control wiring, between the last battery cabinet and the UPS system must be run externally in the 300-450kVA systems. Refer to **Figures 26** through **28** or your submittal drawings for instructions on wiring cabinets in parallel.



NOTE

The 300-750kVA UPS module is approximately 2 to 6 in. (51-152 mm) deeper than the battery cabinet and is not designed to bolt directly to it.

10. **Grounding.** The battery cabinets have ground studs near the busbar connections. Use an equipment grounding conductor to connect the lugs of the cabinets together and to connect the cabinets to the ground busbar in the UPS module.

5.4 Open-Rack Batteries

When batteries other than Liebert battery cabinets are used, a remote battery disconnect switch with overcurrent protection is required per the National Electrical Code. Refer to Required Battery Disconnect Rating in the site planning data tables in **Appendix A** for recommended overcurrent protection ratings. Contact your Liebert sales representative for more information.

1. Install battery racks/cabinets and batteries per manufacturer's installation and maintenance instructions.
2. Verify battery area has adequate ventilation and battery operating temperature complies with manufacturer's specification. Installations using vented lead-acid batteries **MUST** have adequate ventilation to remove explosive gases per local and national codes.
3. Low voltage control wiring must be kept separate from power wiring and run in separate conduits.
4. Ensure that battery racks are properly grounded according to code requirements in your area.

If you have any questions concerning batteries, battery racks or accessories, contact your local sales representative or Liebert Global Services at 1-800-LIEBERT.



CAUTION

Cables between batteries and the UPS modules should be run in matched pairs, positive-with-negative, within each conduit or cable run. Grouping like-polarity cables together (i.e., positive-with-positive and negative-with-negative) can cause stress or damage to the cables, conduit or buswork.

6.0 OPTIONAL TRANSFORMER CABINET

The optional transformer cabinet is a free-standing enclosure that must be bolted to the right side of the UPS module. Forklift slots are included in the cabinet base for ease of handling. Power and control cables for UPS system interconnections are provided with each cabinet.

The optional Transformer Cabinet (**Figures 16, 17, 22, 23 and 25**) encloses the Rectifier Isolation Transformer. The cabinet is cooled by fans, with a disposable filter at the bottom.

7.0 CONFIGURING YOUR NEUTRAL AND GROUND CONNECTIONS

Improper grounding is the largest single cause of UPS installation and start-up problems. This is not an easy subject, since grounding techniques vary significantly from site to site, depending on several factors. The questions you should ask are:

- What is the configuration of the input power source? Most of the recommended schemes for UPS grounding require grounded-*wye* service. The UPS system requires a bypass neutral for sensing and monitoring the quality of the bypass input. If the building service is anything other than a grounded *wye* system (corner grounded delta or impedance grounded *wye*), contact your Liebert representative for details about the Isolated Neutral kits for the System Control Cabinet and UPS modules.

WARNING

If the building service feeding the UPS is any configuration other than those mentioned above, contact your Liebert representative or Liebert Global Services immediately.

A Power-Tie or distributed redundant system has different grounding requirements from stand-alone UPS modules. If using one of those systems, refer to Liebert's Power-Tie configuration user manual, SL-30030.

- What are the UPS input and output voltages? Systems with 480 VAC input and output have significantly different needs from systems with 208/208 VAC.
- What is the connected load? Does the critical load consist of one or more Power Distribution Units (PDUs)? Do the PDUs have isolation transformers?

Proper grounding should be based on NEC Section 250, but safe and proper equipment operation requires further enhancements. The following pages detail Liebert's recommendations for grounding various system configurations to ensure optimal UPS system performance.

NOTE

*Some UPS modules are equipped with input isolation transformers. However, these transformers have no effect upon any system grounding considerations. These modules will be grounded exactly as shown in **Figures 4 through 10**.*

CAUTION

The UPS ground lug must be solidly connected to the service entrance ground by an appropriately sized wire conductor per NEC Article 250. Each conduit or raceway containing phase conductors must also contain a ground wire, both for UPS input and output, which are solidly connected to the ground terminal at each termination point. Conduit-based grounding systems tend to degrade over time. Therefore, using conduit as a grounding conductor for UPS applications may degrade UPS performance and cause improper UPS operation.

7.1 Preferred Grounding Configuration, Wye-Connected Service

The most common configuration of Series 610 UPS Multi-Module Systems is with 480 VAC input, 480 VAC output and a connected load consisting of multiple Power Distribution Units (PDUs) with isolation transformers in the PDUs to produce 208 VAC. For Canadian customers, the UPS modules usually have 600 VAC input and output. The same principles apply if the connected load is an isolation transformer feeding various loads. **Figure 4** shows a typical installation. The Maintenance Bypass Switchgear is shown separately for clarity, but may be contained within the System Control Cabinet (SCC)/switchgear.

Notice that the UPS module input and the system bypass input are connected to a grounded-wye service. In this configuration, the UPS module is not considered a separately derived source.

All of the UPS module output neutrals are solidly connected to the SCC neutral. A parity-sized neutral is recommended between the UPS module and the SCC for best system performance. The SCC neutral is solidly connected to the building service neutral, which is bonded to the grounding conductor at the service entrance equipment.

The isolation transformers in the PDUs are considered a separately derived source. Therefore the PDU neutral should be bonded to the PDU grounding conductor and connected to a local grounding electrode in compliance with NEC 250-26. (PDUs are connected to the critical load output of the SCC, but are not shown in **Figure 4** for clarity.)

Figure 4 Preferred grounding configuration, wye-connected service

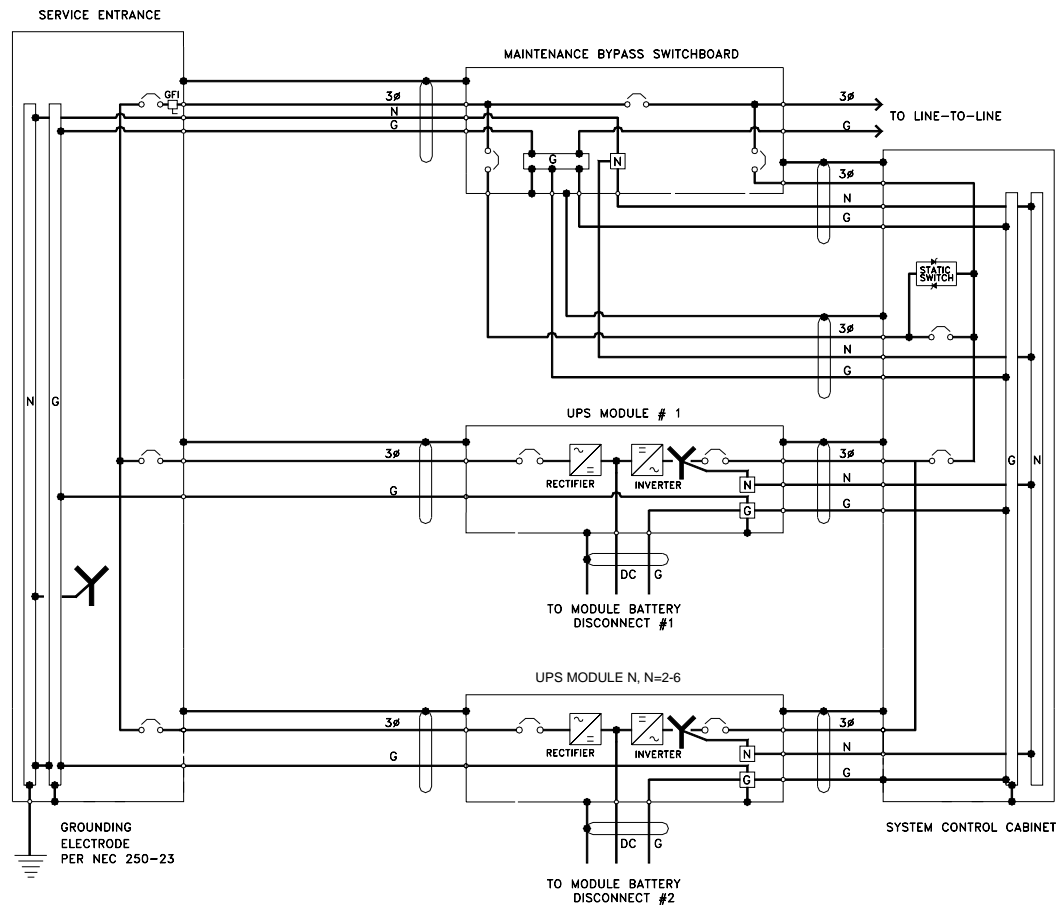

NOTE

Impedance-grounded wye sources require an Isolated Neutral Kit in addition to the grounding and neutral conductors shown above—see 7.5 - Grounding Configuration, Corner-Grounded Delta or Impedance-Grounded Wye.



NOTE

If there is a 4-pole Automatic Transfer Switch (ATS) between the service entrance and the UPS, this configuration cannot be used. Refer to 7.2 - Alternate Grounding Configuration, Wye-Connected Service or 7.3 - Preferred Grounding Configuration With Isolated Bypass to determine a suitable configuration.

7.2 Alternate Grounding Configuration, Wye-Connected Service

This configuration must NOT be used when single-phase loads are directly connected to the UPS.

The alternate configuration is similar to that shown in 7.1 - **Preferred Grounding Configuration, Wye-Connected Service**, except that the service entrance neutral is not brought into the UPS module. In this configuration, the UPS output transformer is considered a separately derived source. The UPS module neutral is bonded to the UPS ground, which is connected to a local grounding electrode in accordance with NEC 250-26.

Please note that this configuration represents a price/performance trade-off. Whenever the UPS module transfers to or from bypass, two AC sources (input and bypass) are briefly connected together and circulating current must flow. In the previous configuration, the current flows through the neutral conductor. In this configuration, the current flows through the ground path, possibly tripping ground fault interrupters (GFIs) and distorting the bypass waveform reference.

Proper adjustment of ground fault interrupters is necessary to avoid unwanted tripping.

Figure 5 Alternate grounding configuration, wye-connected service

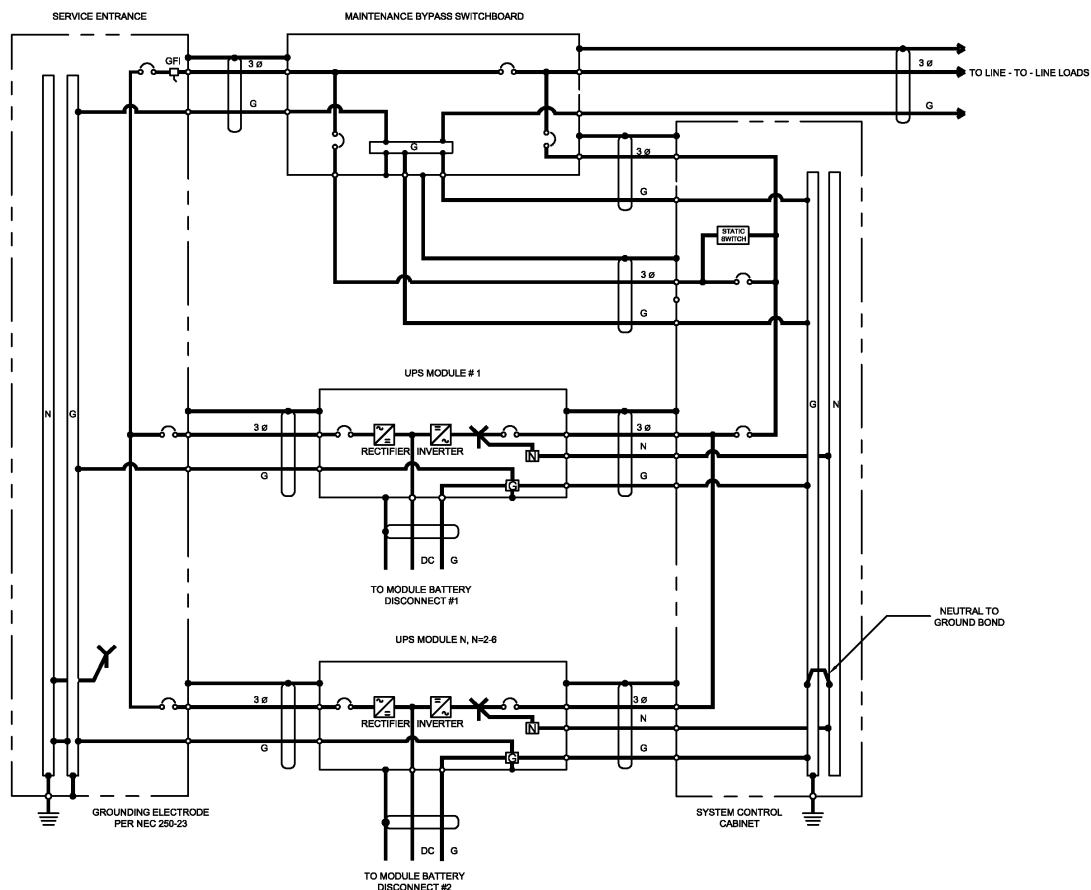

This configuration is reserved for applications that meet all the following criteria:

- The facility has wye-connected service.
- The module rectifier input and bypass input are fed from the same source.
- The connected load is strictly 3-wire (such as one or more PDUs) and does not require a neutral from the UPS.
- Special precautions are taken to prevent tripping the ground fault interrupters. The time delay should be set to at least 0.2 seconds to prevent tripping when the UPS performs a transfer or retransfer operation.



CAUTION

Failure to properly set the ground fault interrupters could cause loss of power to the critical load.

7.3 Preferred Grounding Configuration With Isolated Bypass

Another configuration in this power range is the Multi-Module System with 480 or 600 VAC input, 208 VAC output, a Bypass Isolation Transformer and a connected load consisting of multiple distribution panelboards or switchboards. **Figure 6** shows a typical installation.

The Bypass Transformer provides isolation and may step down the voltage to the bypass input. The Bypass Transformer and the SCC together constitute a separately derived system, since there is no direct electrical connection between the input (service entrance) circuit conductors and the output circuit conductors.



NOTE

Figure 6 shows a wye-connected source, but the same grounding scheme would apply for a delta source at the service entrance.

The bonding of the neutral to the grounding conductor can theoretically be done at either the SCC or the Bypass Transformer. However, we recommend bonding at the Bypass Transformer because the UPS module will sometimes be powered down for maintenance and its output transformer will be out of the circuit. The neutral should be bonded to ground and a local grounding electrode should be installed at the Bypass Transformer, per NEC 250-30.

Figure 6 Preferred grounding configuration with isolated bypass

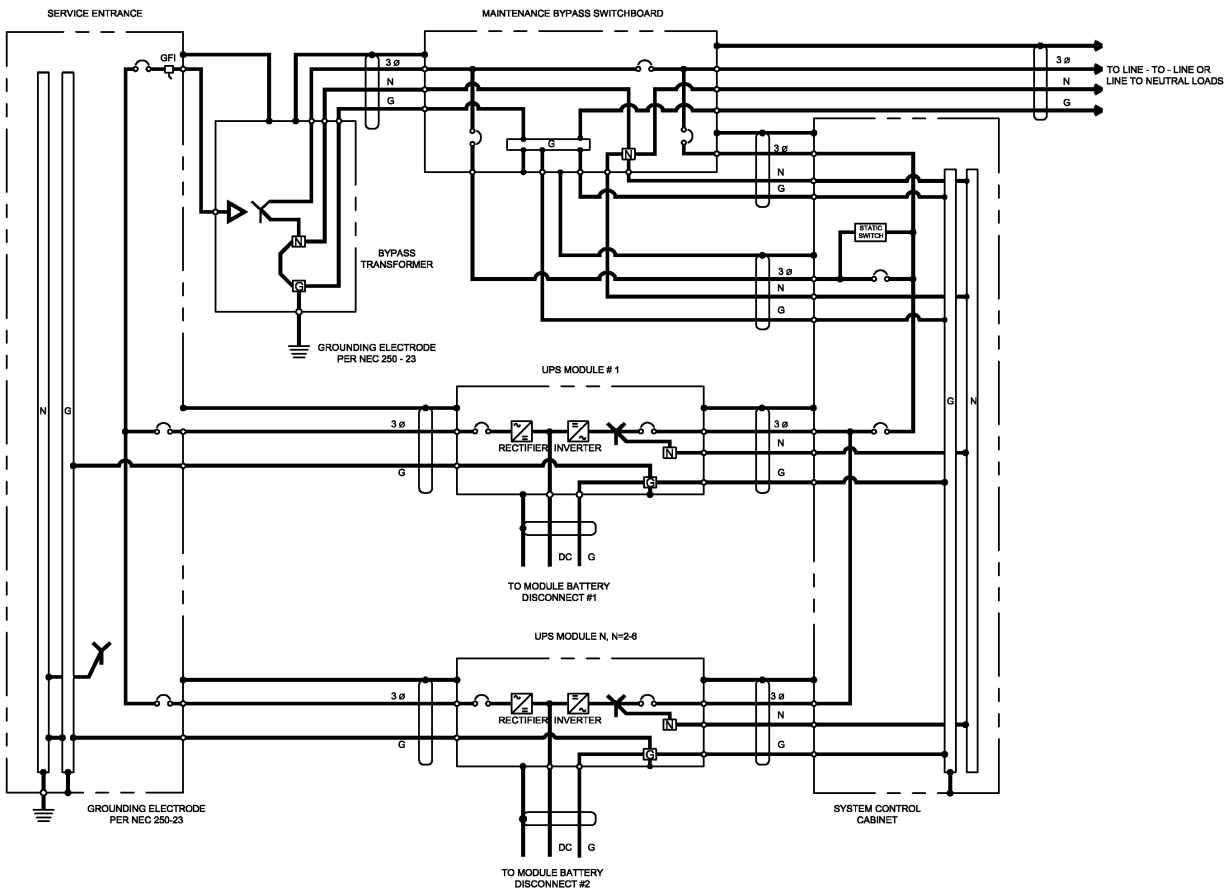

Features of this configuration include:

- The UPS receives its bypass neutral from the Bypass Transformer
- The output is isolated from the input circuit conductors, and
- Some amount of common-mode noise attenuation can be obtained for sensitive loads **if** the UPS module and Bypass Transformer are located close to sensitive loads.

7.4 Alternate Grounding Configuration, Non-Isolated

A few applications in this power range have 208 VAC input and output, and a connected load consisting of multiple Power Distribution Units (PDUs), panelboards, switchboards or other items of load equipment which do not have isolation transformers.

Notice in **Figure 7** that the UPS system main input and bypass input are connected to a grounded-wye service. In this configuration, the UPS system is not considered a separately derived source.

The UPS module output neutral and the load neutral are solidly connected to the building service neutral, which is bonded to the grounding conductor at the service entrance equipment.

Figure 7 Alternate grounding configuration, non-isolated

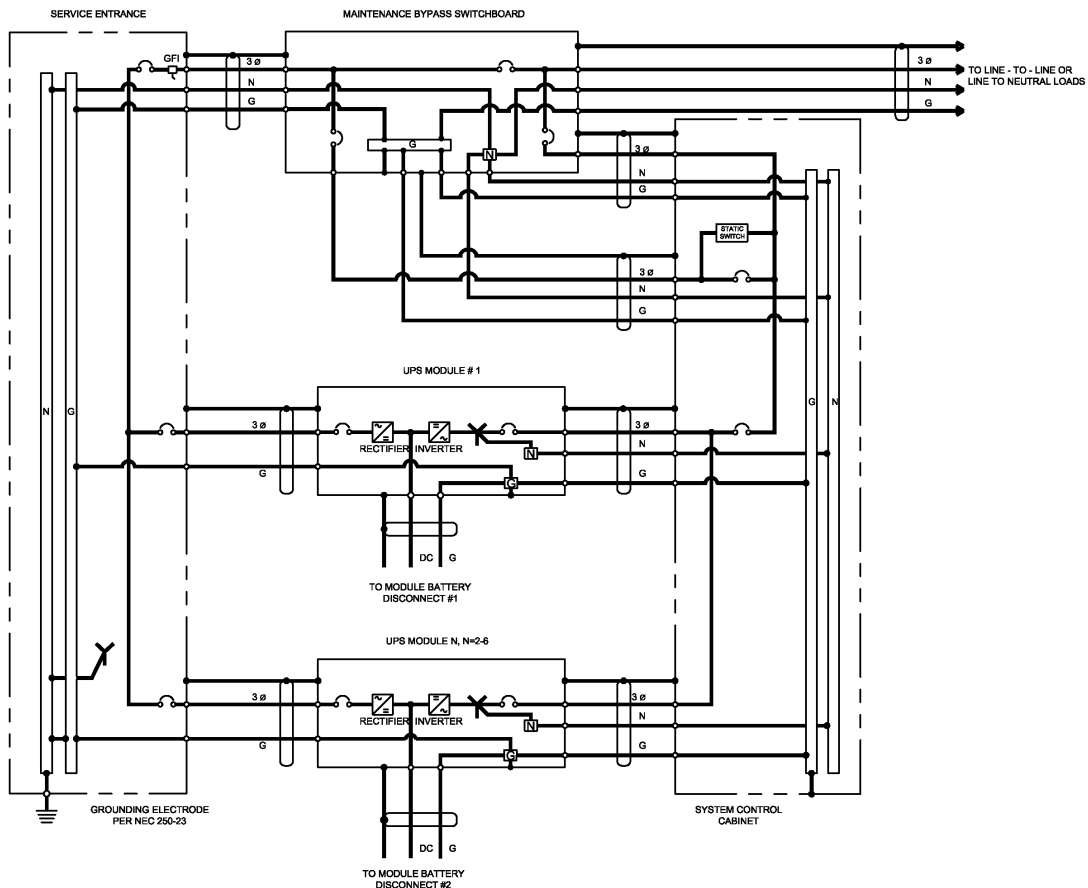

This arrangement may be used for systems with 208 VAC input and output. However, it does not provide any isolation or common-mode noise attenuation for sensitive loads. For this reason, this configuration is not a preferred installation method.



NOTE

If there is a 4-pole Automatic Transfer Switch (ATS) between the service entrance and the UPS, this configuration cannot be used. Refer to 7.3 - Preferred Grounding Configuration With Isolated Bypass to determine a suitable configuration.

7.5 Grounding Configuration, Corner-Grounded Delta or Impedance-Grounded Wye

As previously mentioned, Series 610 SCC requires a bypass input neutral for sensing and monitoring. With a wye-connected input source, the installer should always connect the building service neutral to the System Control Cabinet (SCC) output neutral to achieve this. When the building service is delta-connected, however, the installer must take special steps to ensure reliable UPS functioning.

If the building service is corner-grounded delta or impedance-grounded wye, the UPS requires the Series 610 Isolated Neutral Kit, as do each of the UPS modules. This kit uses control isolation transformers to create a reference point. For this application, the SCC output neutral must **not** be bonded to the SCC ground.

Figure 8 Preferred grounding configuration, corner-grounded delta or impedance-grounded wye

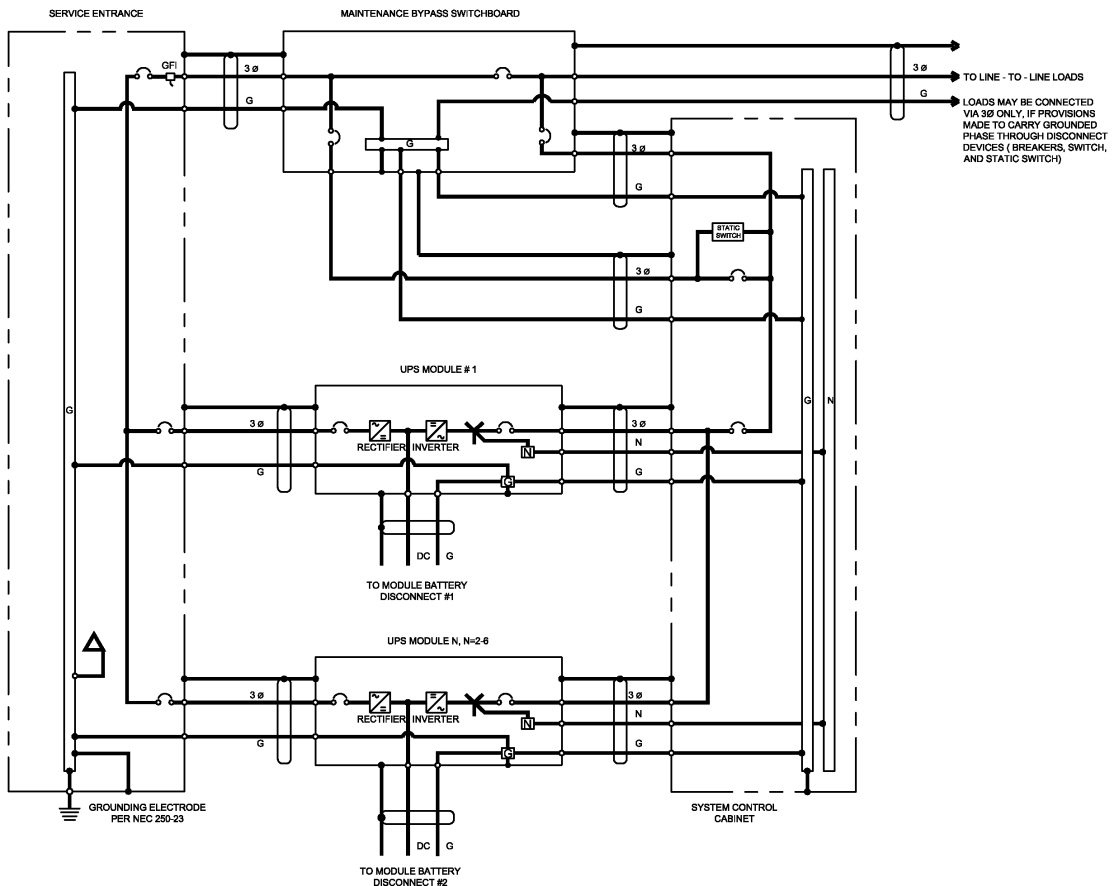
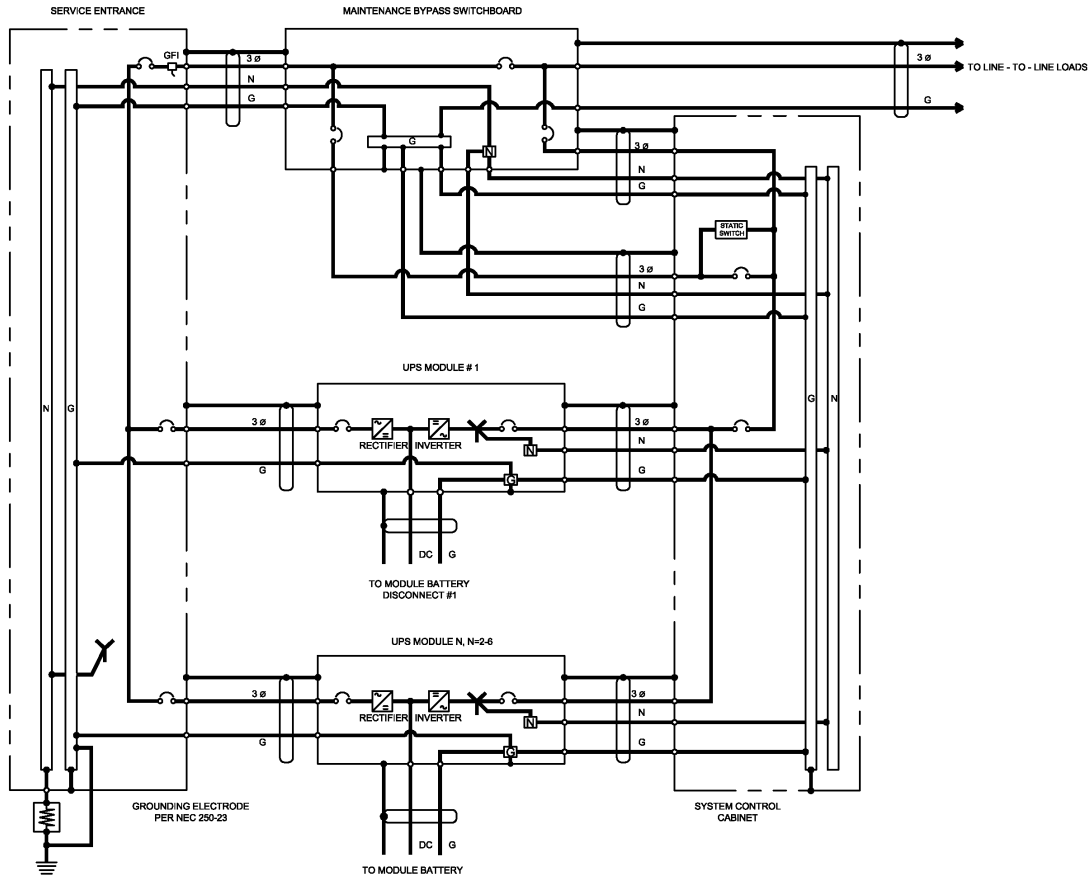

Figure 9 Preferred grounding configuration, impedance-grounded wye



These configurations have the same restrictions as explained in 7.2 - **Alternate Grounding Configuration, Wye-Connected Service**, except for the wye input. The UPS input and bypass must be fed from the same source. The load must be strictly 3-wire. And the GFI time delay should be set to at least 0.2 seconds to prevent tripping during transfer or retransfer operations.



CAUTION

Failure to properly set the ground fault interrupters could cause loss of power to the critical load.

7.6 Preferred Grounding Configuration, Battery Systems

Open-rack battery systems, depending on local code requirements and customer preference, are normally:

1. Floating (ungrounded),
2. Center-tapped and floating or
3. Center tapped and grounded.

Battery cabinet systems must be connected as floating (ungrounded) systems—**Option 1** above. Center-tapped or grounded battery systems are not possible with battery cabinet systems.

Whether the battery system is open-rack or cabinet, the metal rack parts or cabinet must be grounded to the UPS module ground bus.

Figure 10 illustrates how a simple, one-cabinet system would be grounded. For systems with multiple cabinets, the same configuration would apply. However, for simplicity, the installer can connect all the battery cabinet grounds for a particular module together and run a single ground conductor to that UPS module ground (in the same conduit as the phase conductors).

Figure 10 Preferred grounding configuration, battery systems

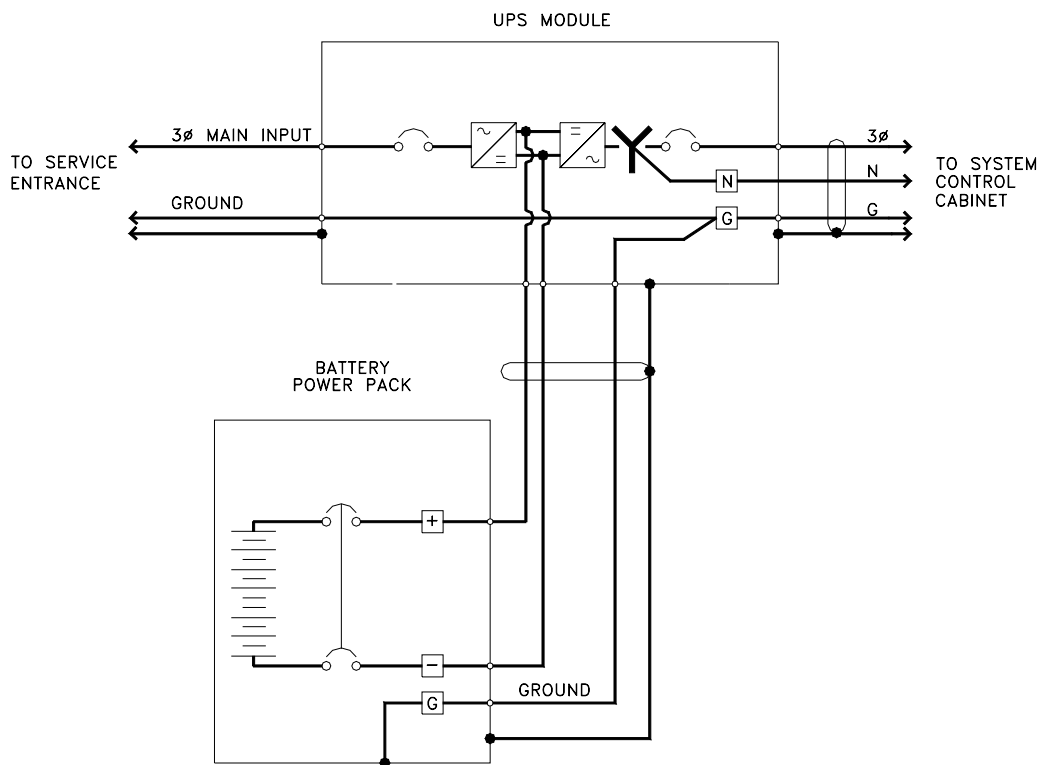

8.0 WIRING CONSIDERATIONS



WARNING

All power connections must be completed by a licensed electrician experienced in wiring this type of equipment. Wiring must be installed in accordance with all applicable national and local electrical codes. Improper wiring may cause damage to the equipment or injury to personnel.

Verify that all incoming high and low voltage power circuits are de-energized and locked out before installing cables or making any electrical connections.

Refer to **Appendix A** and drawings in **11.0 - Installation Drawings**. Determine AC currents for your system (kVA, voltage and options). Also refer to the equipment nameplate for the model number, rating and voltage. For wire termination data, refer to **Tables 2** through **4**. Consult your facility's breaker coordination study to ensure proper handling of fault currents.



NOTE

The instantaneous trip setting of the bypass feeder breaker should be high enough to accommodate short-duration overloads. The bypass static switch inside the SCC can draw up to 10 times the system's rated current for up to three cycles in the event of a downstream fault.



NOTE

*Use 75°C copper wire. Select wire size based on the ampacities in **Table 5** of this manual, a reprint of Table 310-16 and associated notes of the National Electrical Code (NFPA 70).*



CAUTION

The weight of power cables must be adequately supported to avoid stress on busbars and lugs. In addition to weight support, the following restraining method is recommended to control cable movement during external fault conditions:

- Wrap line cables together at 6 and 12 in. (152 and 305mm) from the terminals with five wraps of 3/8 in. (9.5mm) nylon rope or equivalent (tensile strength of 2000 lbs.; 907kg).
- Support the remainder of the cable with five wraps every 6 in. (152mm) or one wrap every 1 in. (25mm).

8.1 Power Wiring

1. Power wiring—rectifier input, bypass input, UPS output and battery cables—must be run in individual, separate conduits or cable trays. Refer to the Outline and Terminal Details drawings (**Figures 14 through 23, 29, 31, 33, 35 and 56 through 61**) for locations of the various power connections within the UPS and ancillary equipment. In particular, note the location of the rectifier input power connections.



CAUTION

Power and control wiring must be separated!

2. Observe local, state and national electrical codes. Verify utility power and its overcurrent protection rating will accommodate the UPS input rating, including battery recharging.
3. A safety ground wire must be run from the building ground to a ground point in the UPS Module Cabinets, ancillary equipment and the Power-Tie Cabinet (if applicable). See **7.0 - Configuring Your Neutral and Ground Connections**. The grounding conductor shall comply with the following conditions of installation:
 - a. An insulated grounding conductor must be sized in accordance with the NEC and local codes. It must be green (with or without one or more yellow stripes) and be installed as part of the branch circuit that supplies the unit or system.
 - b. The grounding conductor described above is to be grounded to earth at the service equipment or, if supplied by a separately derived system, at the supply transformer or motor-generator set in accordance with the instructions in **7.0 - Configuring Your Neutral and Ground Connections**.
 - c. The attachment-plug receptacles in the vicinity of the unit or system are all to be of a grounding type, and the grounding conductors serving these receptacles are to be connected to earth ground at the service equipment.
4. Observe clockwise phase rotation of all power wiring. Phase A leads Phase B leads Phase C. A qualified electrician should check the phase rotation.
5. AC power cables must be rated to meet NEC requirements for voltage drop at the maximum rated system current. DC power cables from the UPS to the battery terminals and return must be sized for less than 2 volts total loop drop at the maximum rated system current.
6. If site equipment includes a backup generator and automatic transfer switch(es), consult the manufacturers of those devices for information on sizing and interfacing to the UPS system.
7. Removable access plates are available for power wiring. Refer to the Outline Drawings for your particular model (**Figures 14, 16, 18, 20, 22, 29, 31, 33, 35 and 56 through 61**).



CAUTION

After cutting holes in the access plates, be certain that no foreign matter (metal shavings, sawdust, insulation or wire fragments, etc.) remains inside the UPS. Likewise be certain to block any “extra” holes in the plates through which foreign matter could later enter the UPS.

Figure 11 Power single line diagrams, Multi-Module configurations*

* These configurations are for illustrative purposes only. They represent only a sample of the possible configurations. Refer to the submittals supplied with your order for more information or for order-specific details.

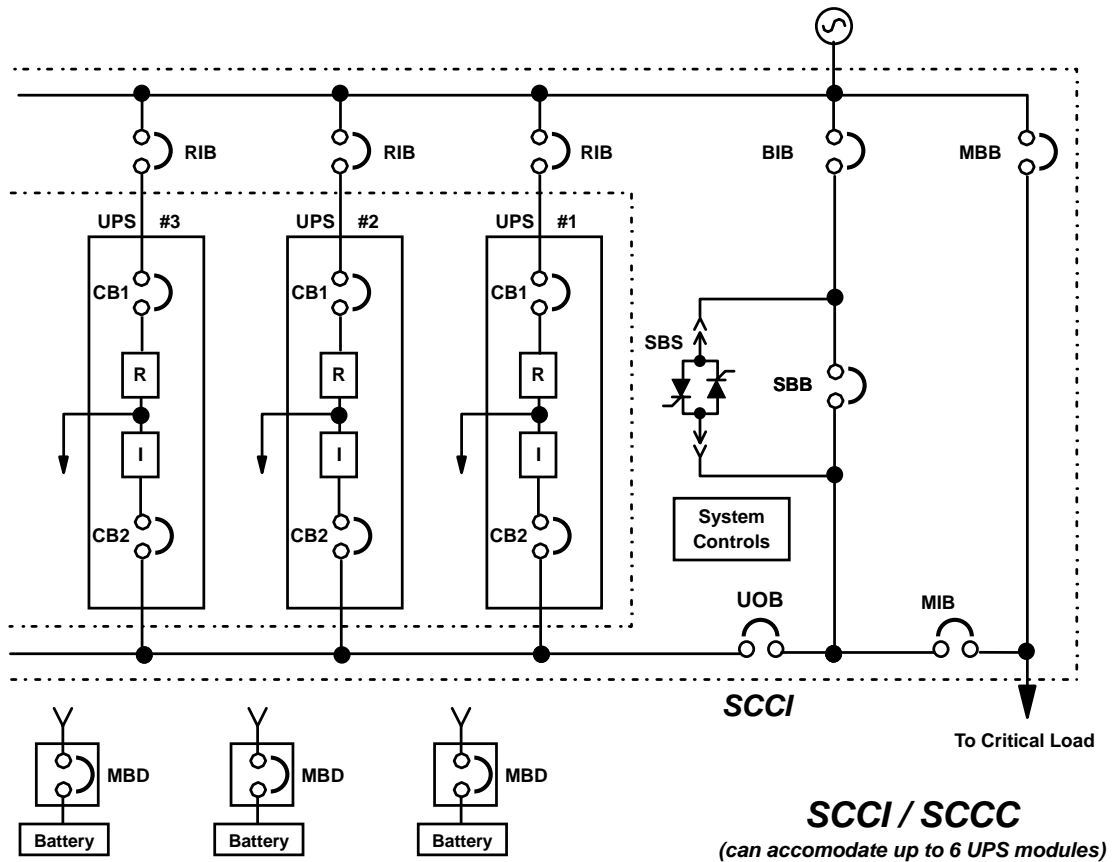
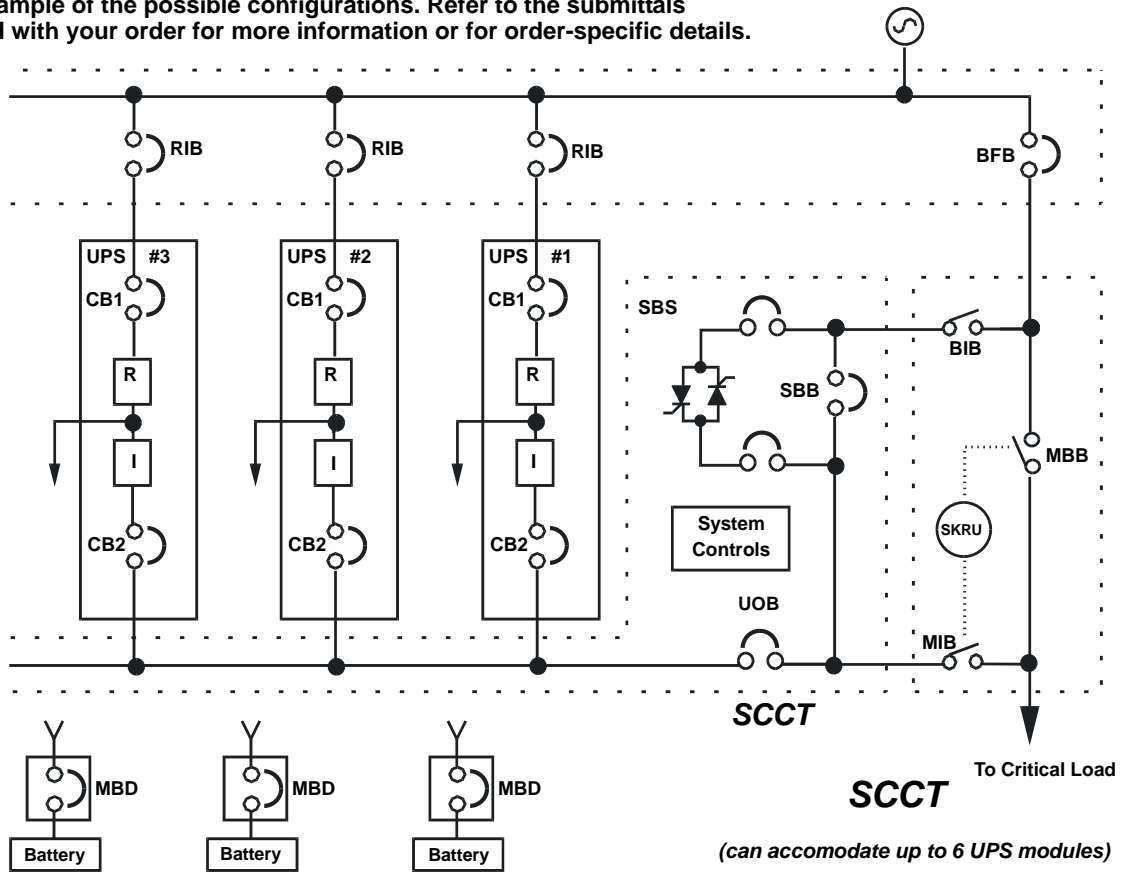

Table 1 Abbreviations for circuit breakers

BFB	Bypass Feeder Breaker
BIB	Bypass Input Breaker
CB1	Module Input Breaker
CB2	Module Output Breaker
MBB	Maintenance Bypass Breaker
MBD	Module Battery Disconnect
MBFB	Maintenance Bypass Feeder Breaker
MIB	Maintenance Isolation Breaker
RIB	Rectifier Input Breaker
SBB	System Bypass Breaker
SSB	Static Bypass Switch
UOB	UPS Output Breaker

8.2 Control Wiring

Control wiring must be flexible stranded, tinned copper and run in individual separate steel conduits. Control wiring must be separated from power wiring. In addition, each control wiring cable group should be run in a separate conduit to minimize control signal interference.

Refer to the Control Connection Locations and Control Wire Lists, **Figures 37** through **55**. Notice that there are nine cable groups in a typical system:

- Cable group 1 carries signals for the Module Battery Disconnect.
- Cable group 2 is for the remote communications options: modem, remote terminal and remote CRT.
- Cable group 3 carries signals for the Remote Emergency Module Off and Remote Emergency Power Off.
- Cable group 4 carries signals for the optional Remote Monitor Panel.
- Cable group 5 is for the optional SiteScan system.
- Cable group 6 carries signals for the reduced battery charge limit and the reduced input current limit.
- Cable group 7 carries signals to and from the maintenance bypass switchgear.
- Cable groups 20 and 21 carry signals for general housekeeping, modules to SCC.

Other cable groups will be required for other optional equipment. If your system has any installed options, special wire lists will be included in your Submittal Drawing Package. Contact your Liebert Sales Representative for assistance if the submittal drawings have been lost or misplaced.

Figures 37 and **38** show the typical location of control connections inside the UPS and SCC. The position of a particular control connection may be different for your system, depending on the model and the installed options.



NOTE

The UPS control and communication wiring are considered Class 2 circuits by NEC standards. However, NEC Class 1 wiring methods are required for these circuits to ensure proper operation of the UPS.

8.3 Battery Wiring

The UPS may be supplied with battery cabinets or a rack-mounted battery system.

Power wiring to the battery cabinet connects positive, negative and ground power cables from the battery cabinet to the associated UPS. Connection of the UPS to the battery cabinet serves to both charge and discharge the batteries (when needed). The battery disconnect (circuit breaker) requires a control cable. Except for interconnect wiring between multiple battery cabinets, power and control cables are field supplied. Refer to **Figures 26** through **28**.



WARNING

A battery intercell connection on each tier of the Liebert battery cabinet is disconnected for safety during shipment. Do not complete these connections. A Liebert Global Services representative will complete these connections as part of start-up. An improperly installed unit can result in injury to personnel or damage to equipment.



CAUTION

Be sure polarity is correct when wiring the battery cabinet to the connected equipment (positive to positive; negative to negative). If polarity is not correct, fuse failures or equipment damage can result.



CAUTION

Cables between batteries and the UPS should be run in matched pairs, positive-with-negative, within each conduit or cable run. Grouping like-polarity cables together (i.e., positive-with-positive and negative-with-negative) can cause stress or damage to the cables, conduit or buswork.

Call Liebert Global Services to schedule installation check-out, final battery intercell connections and start-up.



NOTE

A Liebert Battery Specialist can perform a detailed inspection of the entire battery system to ensure it meets current IEEE standards. This inspection service is recommended because batteries are a critical part of the UPS system.

9.0 WIRING CONNECTIONS



WARNING

Verify that all incoming high and low voltage power circuits are de-energized and locked out before installing cables or making electrical connections.

All power connections must be completed by a licensed electrician experienced in wiring UPS equipment and in accordance with all applicable national and local electrical codes.

Improper wiring may cause damage to the UPS or injury to personnel.



CAUTION

All shielded cables, non-shielded cables, non-shielded control wires, non-shielded battery breaker control wires and non-shielded remote control wires must be housed in individual, separate, steel conduits. Placing multiple cables in the same conduit with other control or power wiring may cause system failure.



NOTE

Use appropriately sized wire as a grounding conductor. Solid metal conduit is not a suitable ground conductor for UPS systems and could negatively affect system performance.

9.1 Specific Connections

Refer to the drawings in this manual and any other drawings provided by Liebert for this installation.

Make all of the following connections:

1. AC power cables from input power source circuit breaker (RIB) to each UPS Module Input. Observe phase rotation.
2. AC power cables from bypass power source circuit breaker (BIB) to UPS system bypass input at System Control Cabinet (SCC). Observe phase rotation.



CAUTION

If there are line-to-neutral loads connected to the UPS output, the bypass input source must be wye connected and have three phases plus neutral plus ground. If the specified input is not available, an isolation transformer is required. Refer to **7.1 - Preferred Grounding Configuration, Wye-Connected Service**, **7.3 - Preferred Grounding Configuration With Isolated Bypass** and **7.4 - Alternate Grounding Configuration, Non-Isolated**.

See **7.0 - Configuring Your Neutral and Ground Connections** for an explanation of proper grounding techniques.

3. AC power cables from each UPS module output to SCC or to switchgear for critical load bus. Observe phase rotation.
4. Each UPS module must have its output neutral connected to the SCC for parallel operation. A minimum of a parity-sized neutral wire is recommended on this circuit for optimum system performance, regardless of the load configuration.
5. AC power cables from UPS System Control Cabinet (SCC) Output to critical load or maintenance bypass panelboard or switchgear. Observe phase rotation.



NOTE

If your installation includes a Maintenance Bypass Panelboard or switchgear, some or all power cables will be terminated in that equipment. Make sure all required wiring between the UPS system and this switchgear is completed per the submittal drawings. Observe phase rotation.

6. The UPS System Control Cabinet (SCC) neutral must be connected to one common point and solidly grounded per requirements of the National Electrical Code. The ground connection inside the UPS SCC/switchgear cabinet may be required by the power wiring configuration at your site.



CAUTION

UPS bypass and system output neutral must be connected to only one common point in the UPS system. This neutral line must be grounded at the source. Refer to **7.0 - Configuring Your Neutral and Ground Connections** for further details.

7. For battery systems: DC power cables (and ground) from battery to UPS module and between battery cabinets/strings. Observe polarity. When multiple conduits are used, an equal number of positive and negative cables should be contained in each conduit.

**NOTE**

DC power and battery circuit breaker control cables are provided with Liebert battery cabinets for use between multiple cabinets when bolted together. Power cables are sized for interconnecting battery cabinets. Battery cabinets specified for bolting up to the UPS are shipped with power cables to connect the battery cabinet system to the UPS module. Field-supplied cabling must be provided to connect stand-alone battery cabinets to the UPS module. Connections from the final battery cabinet to the UPS are provided in the field.

**WARNING**

Do not make any connections between battery tiers in the battery cabinet. These connections will be made by the Liebert Global Services representative during start-up.

8. For remote battery: Install DC power cables (and ground) from battery to Module Battery Disconnect, and then to UPS Module DC bus. Observe polarity.

**CAUTION**

Cables between batteries and the UPS should be run in matched pairs, positive-with-negative, within each conduit or cable run. Grouping like-polarity cables together (i.e., positive-with-positive and negative-with-negative) can cause stress or damage to the cables, conduit or buswork.

9. Module Battery Disconnect control wiring to UPS module and between battery cabinets, if applicable. Wiring must be run in individual separate steel conduit.
10. Control wiring from System Control Cabinet (SCC) to UPS modules. Wiring must be run in individual separate steel conduit. Refer to **Figures 41** through **43** or your submittal drawings.
11. Control connections between the System Control Cabinet (SCC) and the Maintenance Bypass panelboard or switchgear. Refer to **Figure 48** or your submittal drawings.
12. Control wiring to the optional Remote Monitor Panel, if used. Selected alarm messages are also available for customer use through a set of contacts on an optional separate terminal board. Wiring must be run in individual separate steel conduit.
13. Emergency Power Off control wiring (to SCC) must be run in separate steel conduit.
14. Optional communications wiring (to SCC) for terminals, site monitoring or modem must be run in separate steel conduit.
15. Any additional special wiring required at your site. Refer to **Figures 39** through **55** or your submittal drawings.

10.0 WIRING INSPECTION

1. Verify all power connections are tightened per the torque specifications in **Table 3**.
2. Verify all control wire terminations are tight.
3. Verify all power wires and connections have proper spacing between exposed surfaces, phase-to-phase and phase-to-ground.
4. Verify that all control wires are run in steel conduit, separate from all power wiring.

Table 2 Power wiring terminals, factory supplied

UPS Module Rating	Connection Type	Ground
300-450kVA	Busbars for connecting hardware (3/8" on 1-3/4" centers) are provided for all power wiring terminations. A field-supplied lug is required.	Stud 5/16" - 18

Use 75°C copper wire. Select wire size based on the ampacities in **Table 5** of this manual, a reprint of Table 310-16 and associated notes of the National Electrical Code (NFPA 70).

Use commercially available solderless lugs for the wire size required for your application. Refer to **Table 3**. Connect wire to the lug using tools and procedures specified by the lug manufacturer.

Table 3 Torque specifications

NUT AND BOLT COMBINATIONS				
Bolt Shaft Size	Grade 2 Standard		Electrical Connections with Belleville Washers	
	Lb-in	N-m	Lb-in	N-m
1/4	53	6.0	46	5.2
5/16	107	12	60	6.8
3/8	192	22	95	11
1/2	428	22	256	29

CIRCUIT BREAKERS WITH COMPRESSION LUGS (FOR POWER WIRING)		
Wire Size or Range	Lb-in	N-m
#6 - #4	100	11
#3 - #1	125	14
1/0 - 2/0	150	17
3/0 - 200 MCM	200	23
250 - 400 MCM	250	28
500 - 700 MCM	300	34

CIRCUIT BREAKERS WITH COMPRESSION LUGS (FOR POWER WIRING)		
Current Rating	Lb-in	N-m
400 - 1200 Amps	300.00	34.00

TERMINAL BLOCK COMPRESSION LUGS (FOR CONTROL WIRING)		
AWG Wire Size or Range	Lb-in	N-m
#22 - #14	3.5 to 5.3	0.4 to 0.6

NOTE: Use the values in this table unless the equipment is labeled with a different torque value.

Table 4 Field-supplied lugs

One-Hole Lugs						
T & B ¹ Lug Style		Wire Size	Bolt Size (Inches)	Tongue Width (Inches)	T & B ¹ P/N	Liebert P/N
1	Stak-On	#1 AWG	3/8	0.76	H973	12-714255-46
2		1/0 AWG	3/8	0.88	J973	12-714255-56
3		2/0 AWG	3/8	1.00	K973	12-714255-66
4		3/0 AWG	3/8	1.10	L973	12-714255-76
5		4/0 AWG	3/8	1.20	M973	12-714255-86
6	Color-Keyed Aluminum/ Copper	#1 AWG	3/8	0.75	60124	—
7		1/0 AWG	3/8	0.88	60130	—
8		2/0 AWG	3/8	0.97	60136	—
9		3/0 AWG	3/8	1.06	60142	—
10	Color-Keyed Copper Cable Long Barrel	#1 AWG	5/16	0.67	54947BE	—
11		1/0 AWG	3/8	0.75	54909BE	—
12		2/0 AWG	3/8	0.81	54910BE	—
13		3/0 AWG	1/2	0.94	54965BE	—
14		4/0 AWG	1/2	1.03	54970BE	—
15		250 MCM	1/2	1.09	54913BE	—
16	Narrow-Tongue Copper Cable	350 MCM	1/2	1.09	55165	—
17		500 MCM	1/2	1.20	55171	—

1. Manufacturer: Thomas & Betts (T & B), 1-800-862-8324

Table 5 Table 310-16, National Electrical Code (Reprint)

Allowable Ampacities of Insulated Conductors Rated 0-2000 Volts, 60° to 90°C (140° to 194°F)¹

Not More Than Three Conductors in Raceway or Cable or Earth (Directly Buried), Based on Ambient Temperature of 30°C (86°F)

SIZE	TEMPERATURE RATING OF CONDUCTOR. SEE TABLE 310-13.						SIZE
	60°C (140°F)	75°C (167°F)	90°C (194°F)	60°C (140°F)	75°C (167°F)	90°C (194°F)	
	TYPES TW= UF=	TYPES FEPW= RH, RHW= THHW= THW= THWN= XHHW= USE= ZW=	TYPES TBS, SA, SIS, FEP= FEPB= MI, RHH= RHW-2 THHN= THHW= THW-2, THWN-2, USE-2, XHH, XHHW= XHHW-2, ZW-2	TYPES TW= UF=	TYPES RH= RHW= THHW= THW= THWN= XHHW= USE=	TYPES TBS, SA, SIS, THHN= THHW= THW-2, THWN-2, RHH= RHW-2, USE-2, XHH, XHHW= XHHW-2, ZW-2	
AWG kcmil	COPPER			ALUMINUM OR COPPER-CLAD ALUMINUM			AWG kcmil
18	14
16	18
14*	20	20	25
12*	25	25	30	20	20	25	12*
10*	30	35	40	25	30	35	10*
8	40	50	55	30	40	45	8*
6	55	65	75	40	50	60	6
4	70	85	95	55	65	75	4
3	85	100	110	65	75	85	3
2	95	115	130	75	90	100	2
1	110	130	150	85	100	115	1
1/0	125	150	170	100	120	135	1/0
2/0	145	175	195	115	135	150	2/0
3/0	165	200	225	130	155	175	3/0
4/0	195	230	260	150	180	205	4/0
250	215	255	290	170	205	230	250
300	240	285	320	190	230	255	300
350	260	310	350	210	250	280	350
400	280	335	380	225	270	305	400
500	320	380	430	260	310	350	500
600	355	420	475	285	340	385	600
700	385	460	520	310	375	420	700
750	400	475	535	320	385	435	750
800	410	490	555	330	395	450	800
900	435	520	585	355	425	480	900
1000	455	545	615	375	445	500	1000
1250	495	590	665	405	485	545	1250
1500	520	625	705	435	520	585	1500
1750	545	650	735	455	545	615	1750
2000	560	665	750	470	560	630	2000
CORRECTION FACTORS							
Ambient Temp °C	For ambient temperatures other than 30°C (86°F), multiply the allowable ampacities shown above by the appropriate factor shown below.						Ambient Temp °F
21-25	1.08	1.05	1.04	1.08	1.05	1.04	70-77
26-30	1.00	1.00	1.00	1.00	1.00	1.00	78-86
31-35	.91	.94	.96	.91	.94	.96	87-95
36-40	.82	.88	.91	.82	.88	.91	96-104
41-45	.71	.82	.87	.71	.82	.87	105-113
46-50	.58	.75	.82	.58	.75	.82	114-122
51-55	.41	.67	.76	.41	.67	.76	123-131
56-6058	.7158	.71	132-140
61-7033	.5833	.58	141-158
71-804141	159-176

* Unless otherwise specifically permitted in Section 240-3 of this Code, the overcurrent protection for conductor types marked with an asterisk (*) shall not exceed 15 amperes for No. 14, 20 amperes for No. 12, and 30 amperes for No. 10 copper; or 15 amperes for No. 12 and 25 amperes for No. 10 aluminum and copper-clad aluminum after any correction factors for ambient temperature and number of conductors have been applied.

1. Reprinted with permission from NEC 1999, NFPA 70, the *National Electrical Code*[®], Copyright 1998, National Fire Protection Association, Quincy, MA 02269. This reprinted material is not the complete and official position of the National Fire Protection Association, on the referenced subject which is represented only by the standard in its entirety.

11.0 INSTALLATION DRAWINGS

Figure 12 One-line diagram, two-module parallel system with two-breaker maintenance bypass

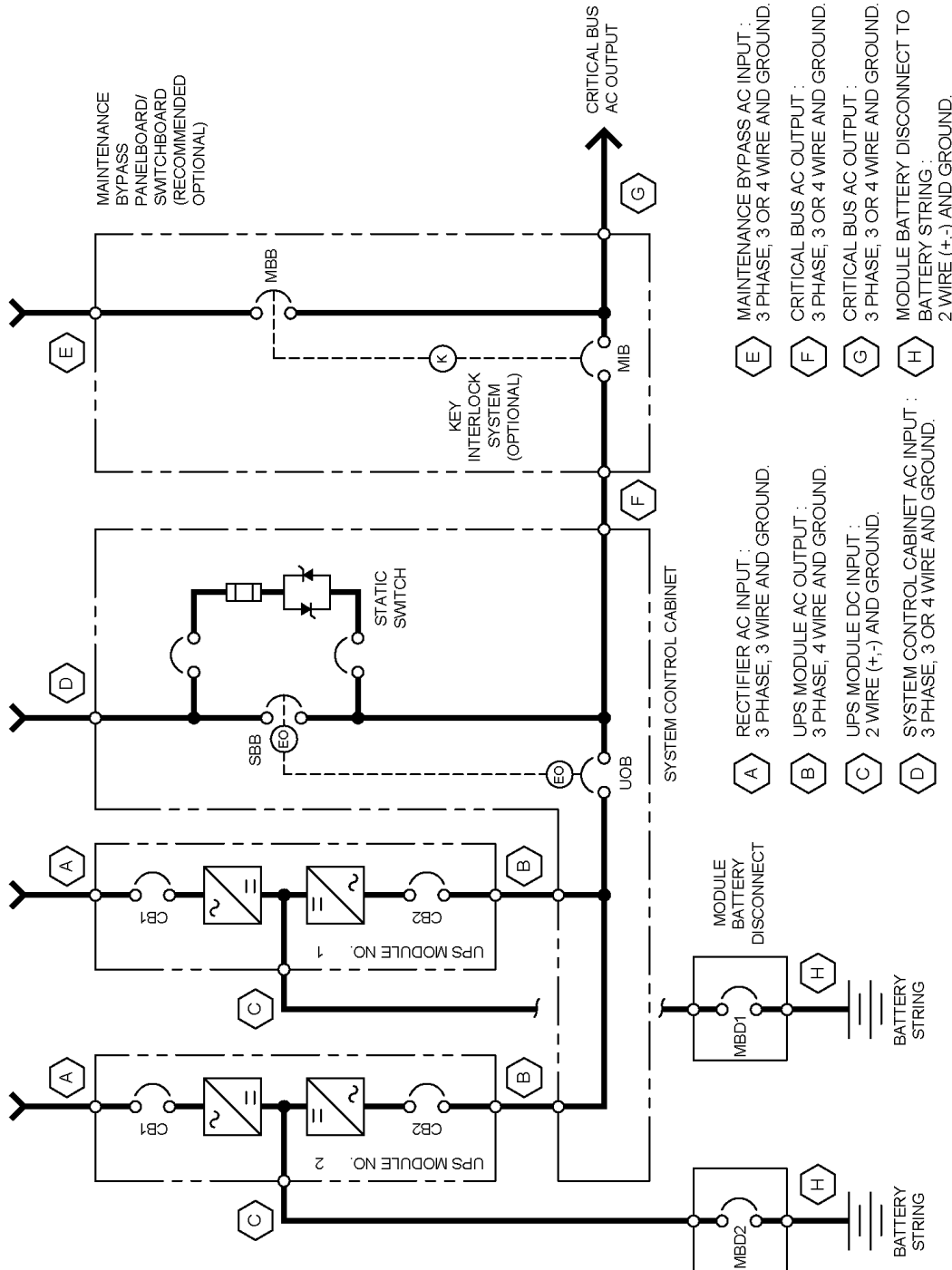

97-797600-169
Rev. 03

Figure 13 One-line diagram, four-module parallel system with three-breaker maintenance bypass

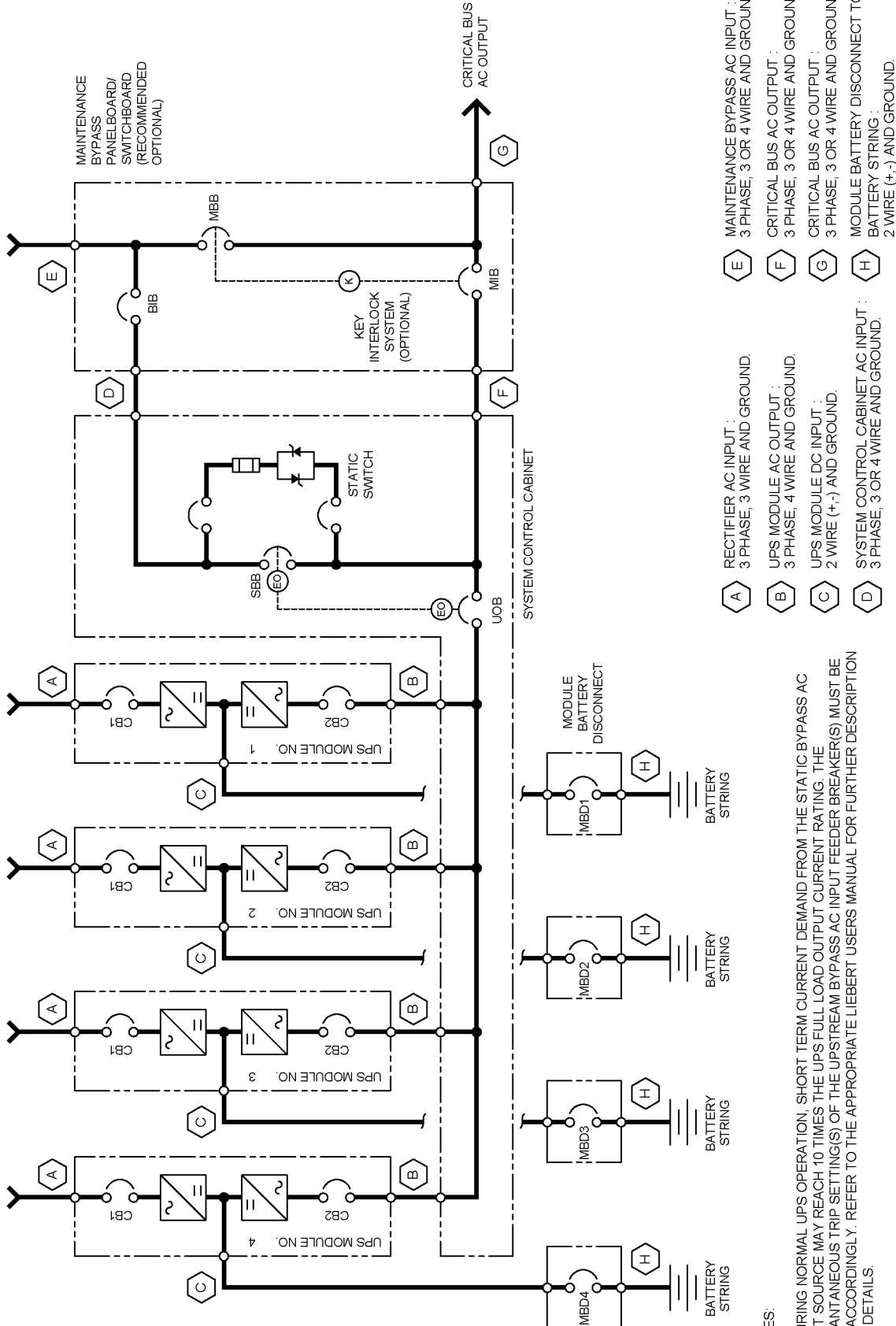

- (A) RECTIFIER AC INPUT : 3 PHASE, 3 WIRE AND GROUND.
- (B) UPS MODULE AC OUTPUT : 3 PHASE, 4 WIRE AND GROUND.
- (C) UPS MODULE DC INPUT : 2 WIRE (+,-) AND GROUND.
- (D) SYSTEM CONTROL CABINET AC INPUT : 3 PHASE, 3 OR 4 WIRE AND GROUND.
- (E) MAINTENANCE BYPASS AC INPUT : 3 PHASE, 3 OR 4 WIRE AND GROUND.
- (F) CRITICAL BUS AC OUTPUT : 3 PHASE, 3 OR 4 WIRE AND GROUND.
- (G) CRITICAL BUS AC OUTPUT : 3 PHASE, 3 OR 4 WIRE AND GROUND.
- (H) MODULE BATTERY DISCONNECT TO BATTERY STRING : 2 WIRE (+,-) AND GROUND.

NOTES:
 1. DURING NORMAL UPS OPERATION, SHORT TERM CURRENT DEMAND FROM THE STATIC BYPASS AC INPUT SOURCE MAY REACH 10 TIMES THE UPS FULL LOAD OUTPUT CURRENT RATING. THE INSTANTANEOUS TRIP SETTING(S) OF THE UPS/STREAM BYPASS AC INPUT FEEDER BREAKER(S) MUST BE SET ACCORDINGLY. REFER TO THE APPROPRIATE LIEBERT USERS MANUAL FOR FURTHER DESCRIPTION AND DETAILS.

97-797600-176
 Rev. 03

Figure 14 Outline drawing, 300kVA Multi-Module UPS

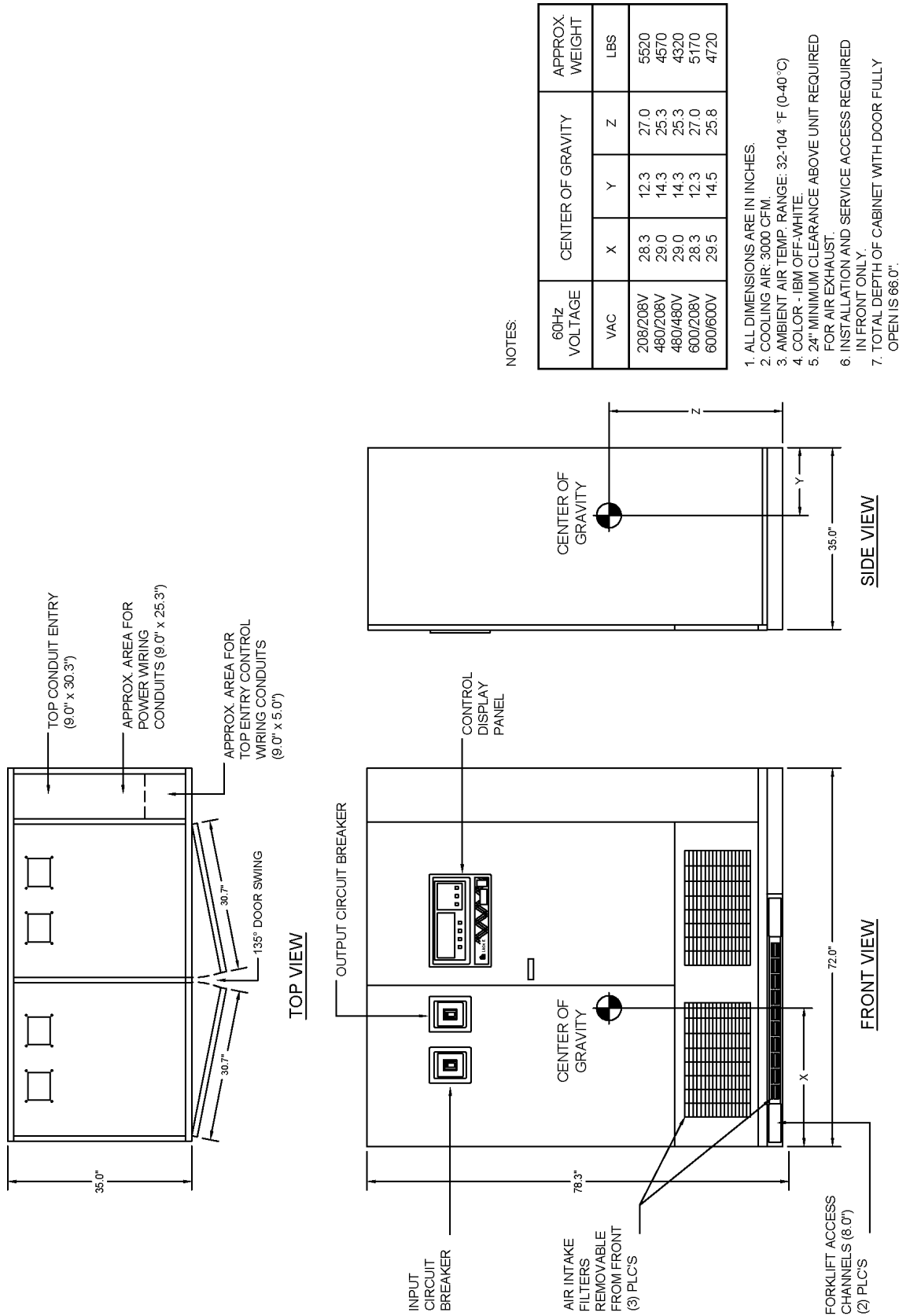

NOTES:

60HZ VOLTAGE	CENTER OF GRAVITY			APPROX WEIGHT LBS
	X	Y	Z	
208/208V	28.3	12.3	27.0	5520
480/208V	29.0	14.3	25.3	4570
480/480V	29.0	14.3	25.3	4320
600/208V	28.3	12.3	27.0	5170
600/600V	29.5	14.5	25.8	4720

1. ALL DIMENSIONS ARE IN INCHES.
2. COOLING AIR: 3000 CFM.
3. AMBIENT AIR TEMP. RANGE: 32-104 °F (0-40 °C)
4. COLOR - IBM OFF-WHITE.
5. 24" MINIMUM CLEARANCE ABOVE UNIT REQUIRED FOR AIR EXHAUST.
6. INSTALLATION AND SERVICE ACCESS REQUIRED IN FRONT ONLY.
7. TOTAL DEPTH OF CABINET WITH DOOR FULLY OPEN IS 66.0".

88-797638-84
Rev. 06

Figure 15 Terminal details, 300kVA Multi-Module UPS

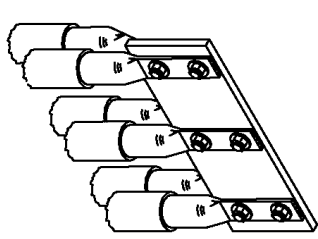

TYPICAL DETAIL OF CUSTOMER CONNECTION TO BUS BAR

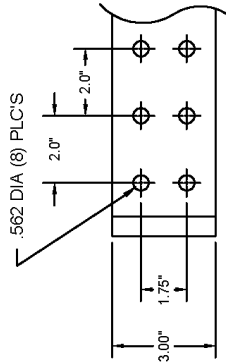

BUS BAR NEUTRAL DETAIL "C"

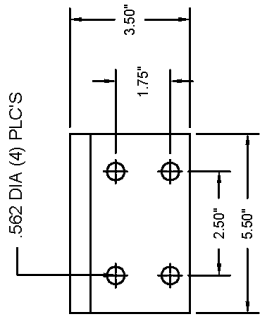

GROUND BUS DETAIL "B"

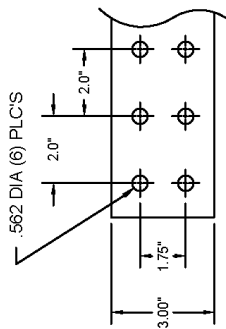

BUS BAR DETAIL "A"

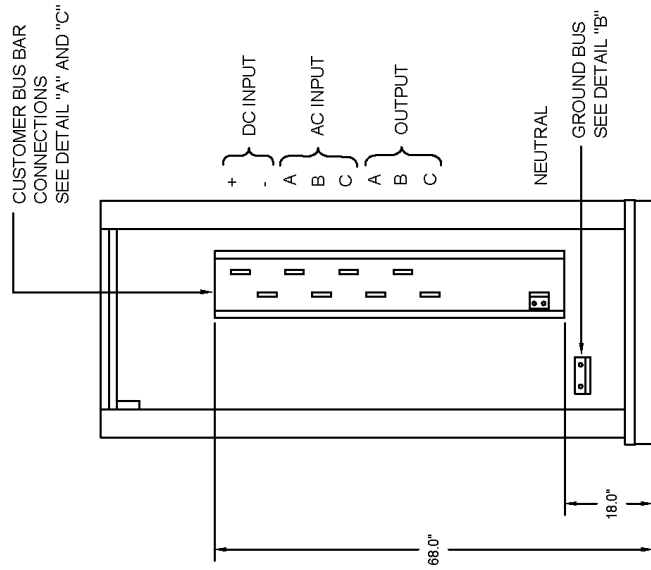

SIDE VIEW

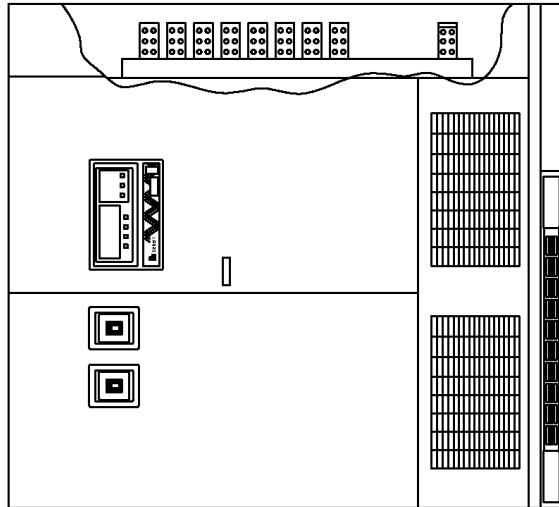

FRONT VIEW

NOTES:

1. LUGS FOR BUS BAR CONNECTION, PROVIDED BY OTHERS.
2. ALL DIMENSIONS ARE IN INCHES.

88-797638-93
Rev. 08

Figure 16 Outline drawing, 300kVA Multi-Module UPS with input ISO transformer cabinet (optional)

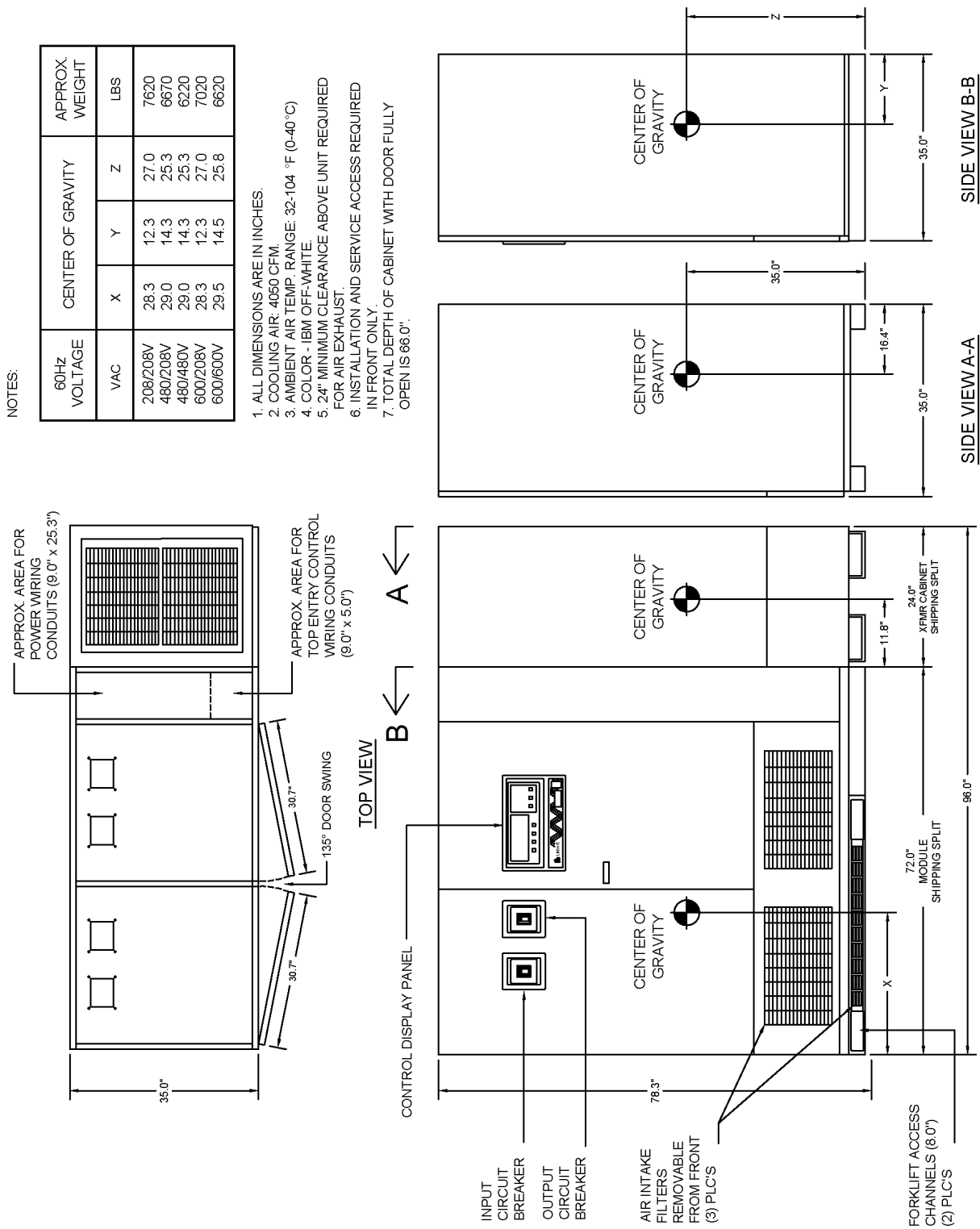

NOTES:

60HZ VOLTAGE	CENTER OF GRAVITY			APPROX. WEIGHT
	X	Y	Z	
VAC				LBS
208/208V	28.3	12.3	27.0	7620
480/208V	29.0	14.3	25.3	6670
480/480V	29.0	14.3	25.3	6220
600/208V	28.3	12.3	27.0	7020
600/600V	29.5	14.5	25.8	6620

1. ALL DIMENSIONS ARE IN INCHES.
2. COOLING AIR: 4050 CFM.
3. AMBIENT AIR TEMP. RANGE: 32-104 °F (0-40 °C)
4. COLOR - IBM OFF-WHITE.
5. 24" MINIMUM CLEARANCE ABOVE UNIT REQUIRED FOR AIR EXHAUST.
6. INSTALLATION AND SERVICE ACCESS REQUIRED IN FRONT ONLY.
7. TOTAL DEPTH OF CABINET WITH DOOR FULLY OPEN IS 66.0".

88-797638-61
Rev. 07

Figure 17 Terminal details, 300kVA Multi-Module UPS with input ISO transformer cabinet (optional)

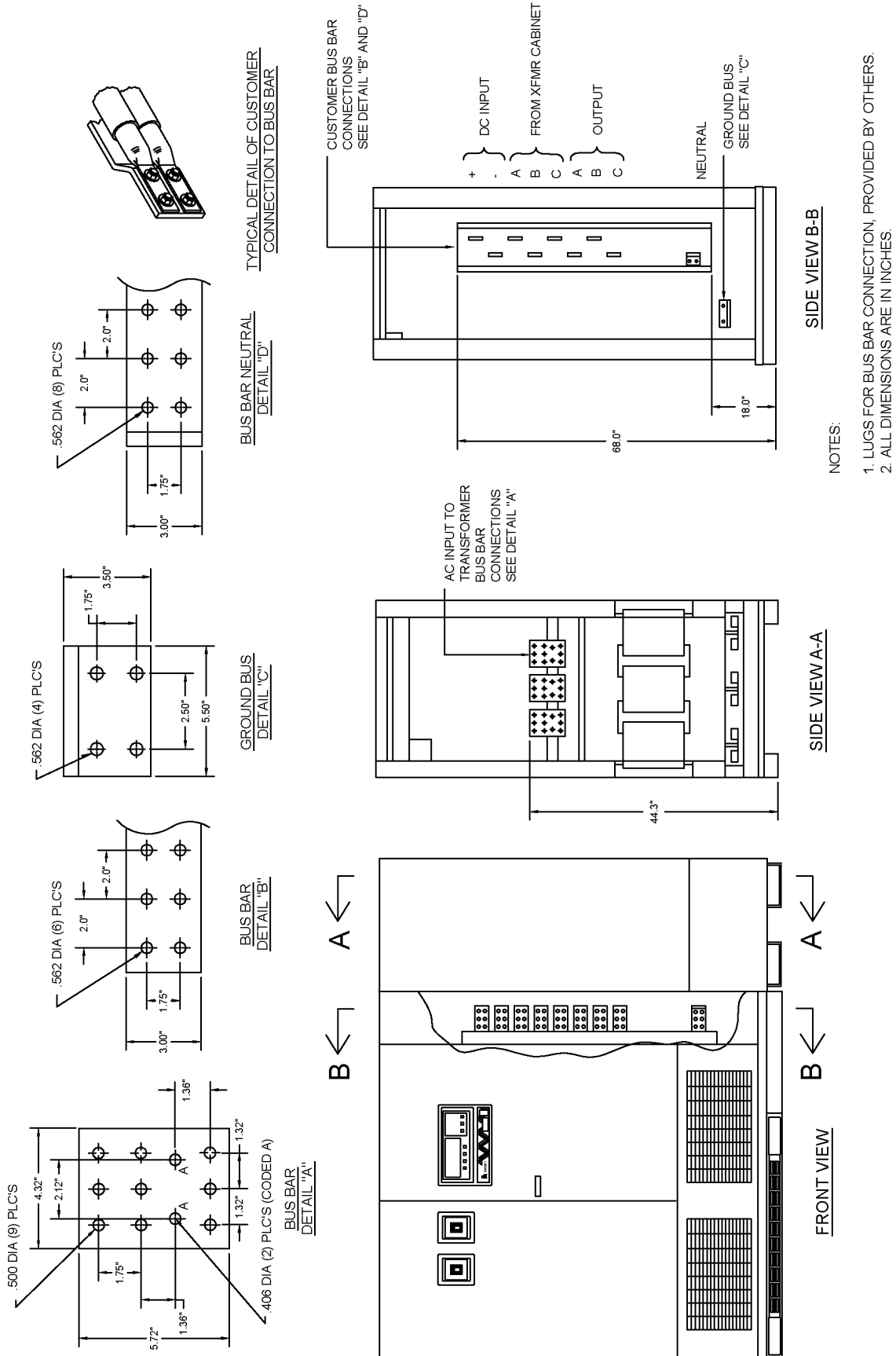

88-797638-71
 Rev. 08

Figure 18 Outline drawing, 400kVA Multi-Module UPS

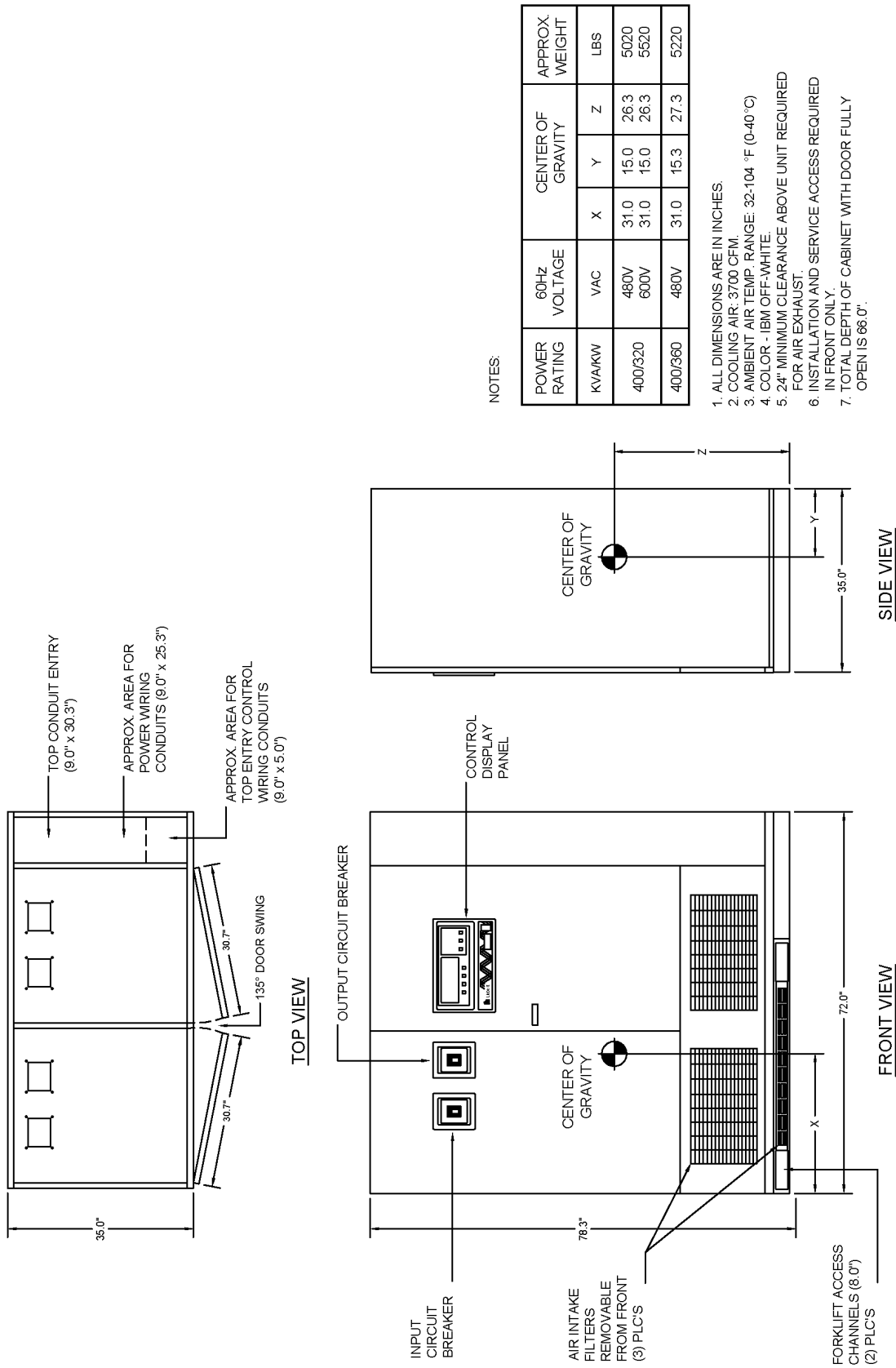

NOTES:

POWER RATING	60HZ VOLTAGE	CENTER OF GRAVITY			APPROX. WEIGHT
		X	Y	Z	
KVA/KW	VAC				LBS
400/320	480V	31.0	15.0	26.3	5020
400/360	600V	31.0	15.0	26.3	5220
	480V	31.0	15.3	27.3	5220

1. ALL DIMENSIONS ARE IN INCHES.
2. COOLING AIR: 3700 CFM.
3. AMBIENT AIR TEMP. RANGE: 32-104 °F (0-40°C)
4. COLOR - IBM OFF-WHITE.
5. 24" MINIMUM CLEARANCE ABOVE UNIT REQUIRED FOR AIR EXHAUST.
6. INSTALLATION AND SERVICE ACCESS REQUIRED IN FRONT ONLY.
7. TOTAL DEPTH OF CABINET WITH DOOR FULLY OPEN IS 66.0".

86-797648-84
Rev. 06

Figure 19 Terminal details, 400kVA Multi-Module UPS

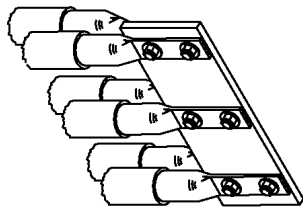

TYPICAL DETAIL OF CUSTOMER CONNECTION TO BUS BAR

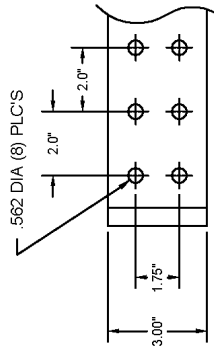

BUS BAR NEUTRAL DETAIL "C"

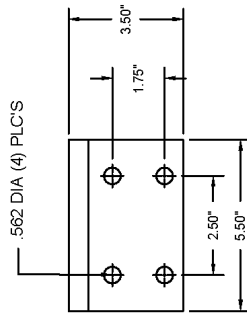

GROUND BUS DETAIL "B"

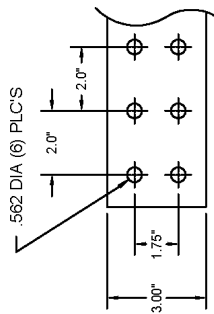

BUS BAR DETAIL "A"

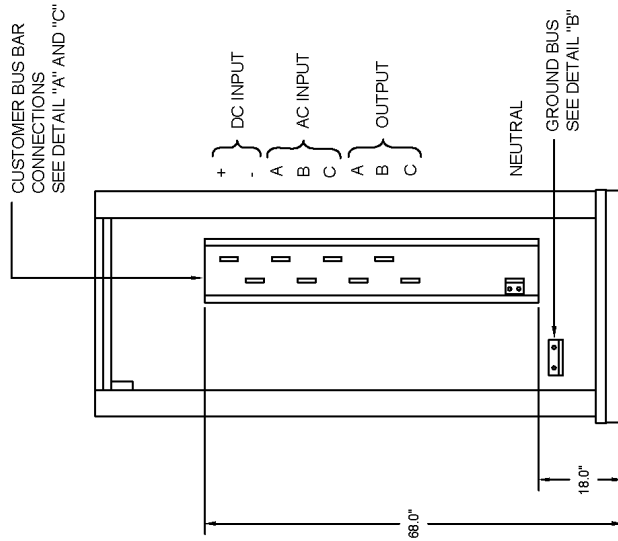

SIDE VIEW

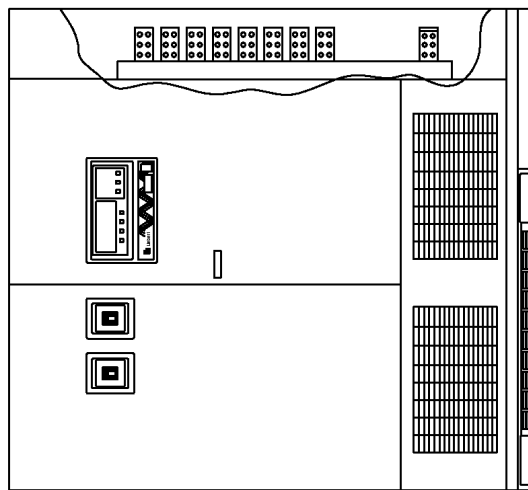

FRONT VIEW

NOTES:

1. LUGS FOR BUS BAR CONNECTION, PROVIDED BY OTHERS.
2. ALL DIMENSIONS ARE IN INCHES.

88-797648-93
Rev. 04

Figure 20 Outline drawing, 450kVA Multi-Module UPS, 480V input, 480V output

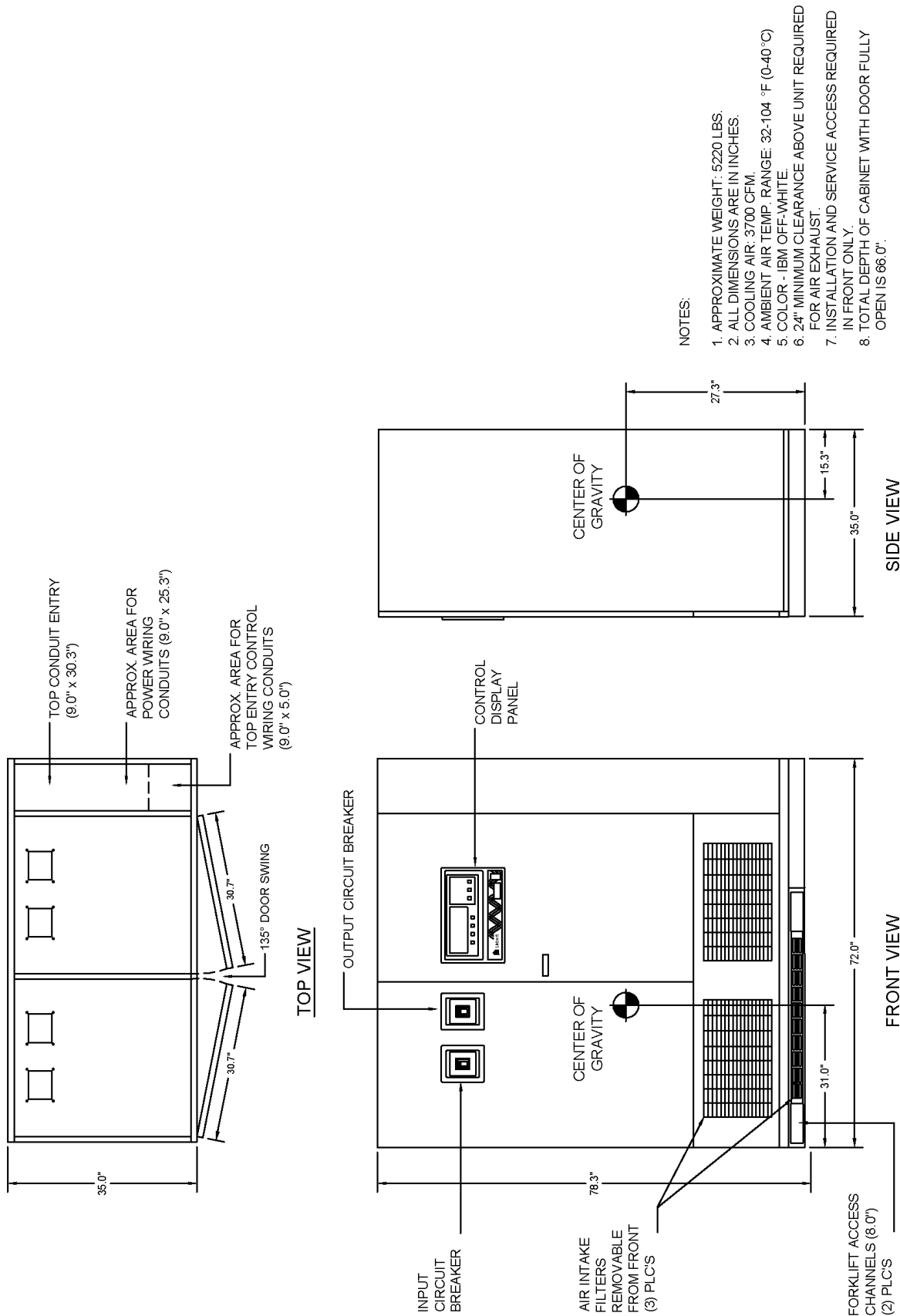

- NOTES:
1. APPROXIMATE WEIGHT: 5220 LBS.
 2. ALL DIMENSIONS ARE IN INCHES.
 3. COOLING AIR: 3700 CFM
 4. AMBIENT AIR TEMP. RANGE: 32-104 °F (0-40 °C)
 5. COLOR - IBM OFF-WHITE
 6. 24" MINIMUM CLEARANCE ABOVE UNIT REQUIRED FOR AIR EXHAUST.
 7. INSTALLATION AND SERVICE ACCESS REQUIRED IN FRONT ONLY.
 8. TOTAL DEPTH OF CABINET WITH DOOR FULLY OPEN IS 66.0".

88-797655-84
Rev. 06

Figure 21 Terminal details, 450kVA Multi-Module UPS, 480V input, 480/277V output

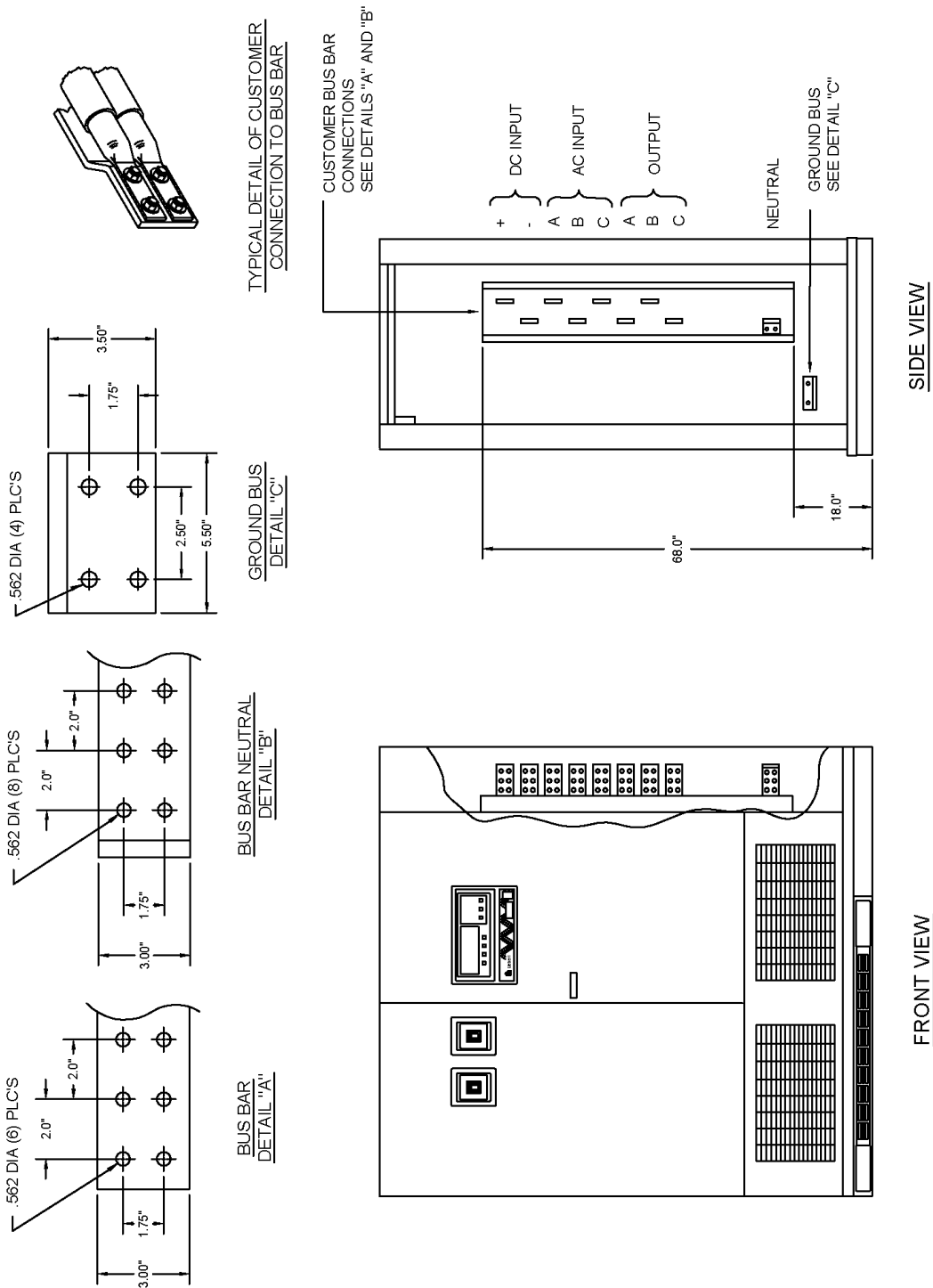

NOTES:

1. LUGS FOR BUS BAR CONNECTION, PROVIDED BY OTHERS.
2. ALL DIMENSIONS ARE IN INCHES.

88-797655-94
 Rev. 05

Figure 22 Outline drawing, 400 & 450kVA Multi-Module UPS with input ISO transformer cabinet (optional)

88-797648-95
Rev. 02

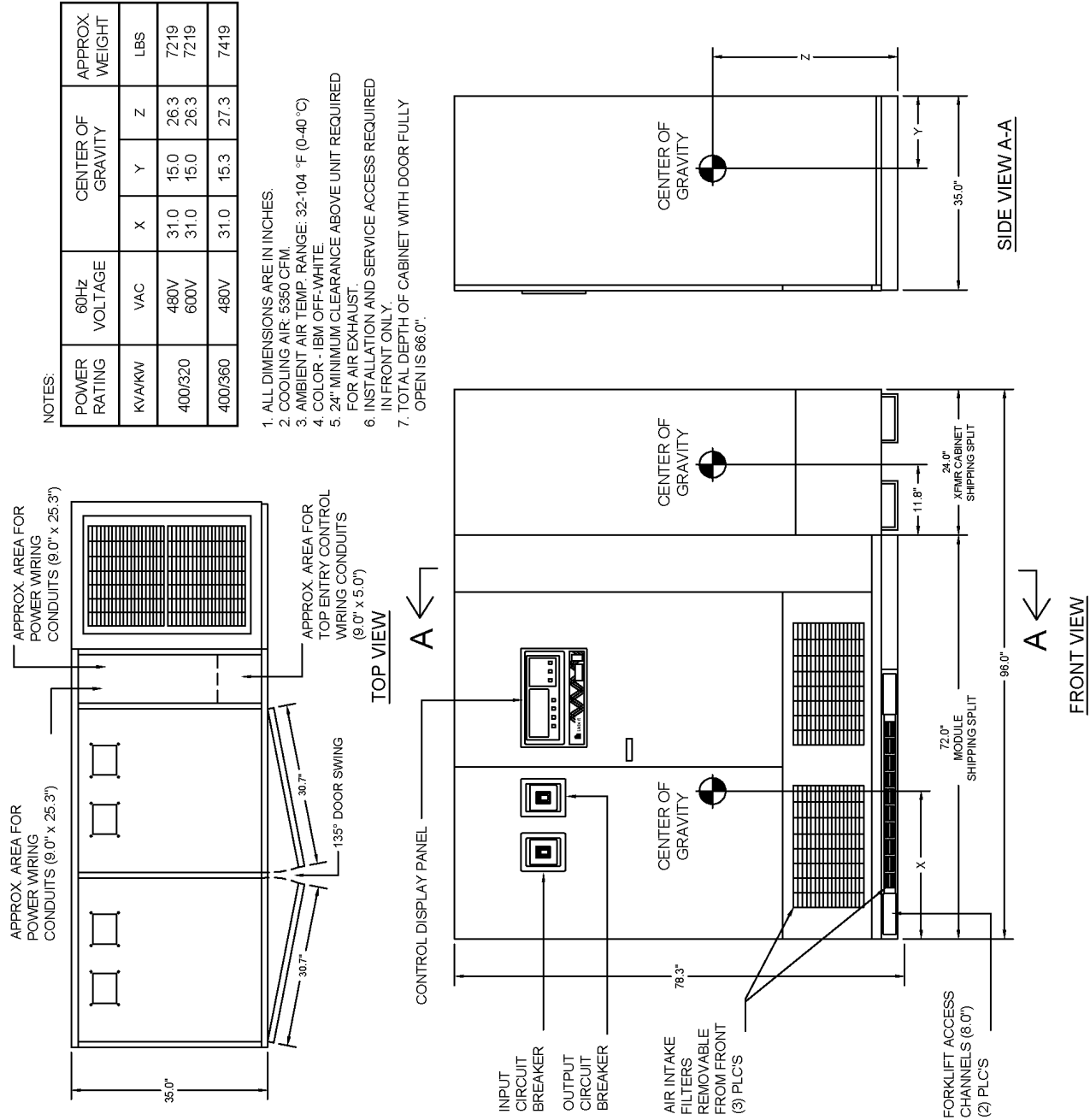
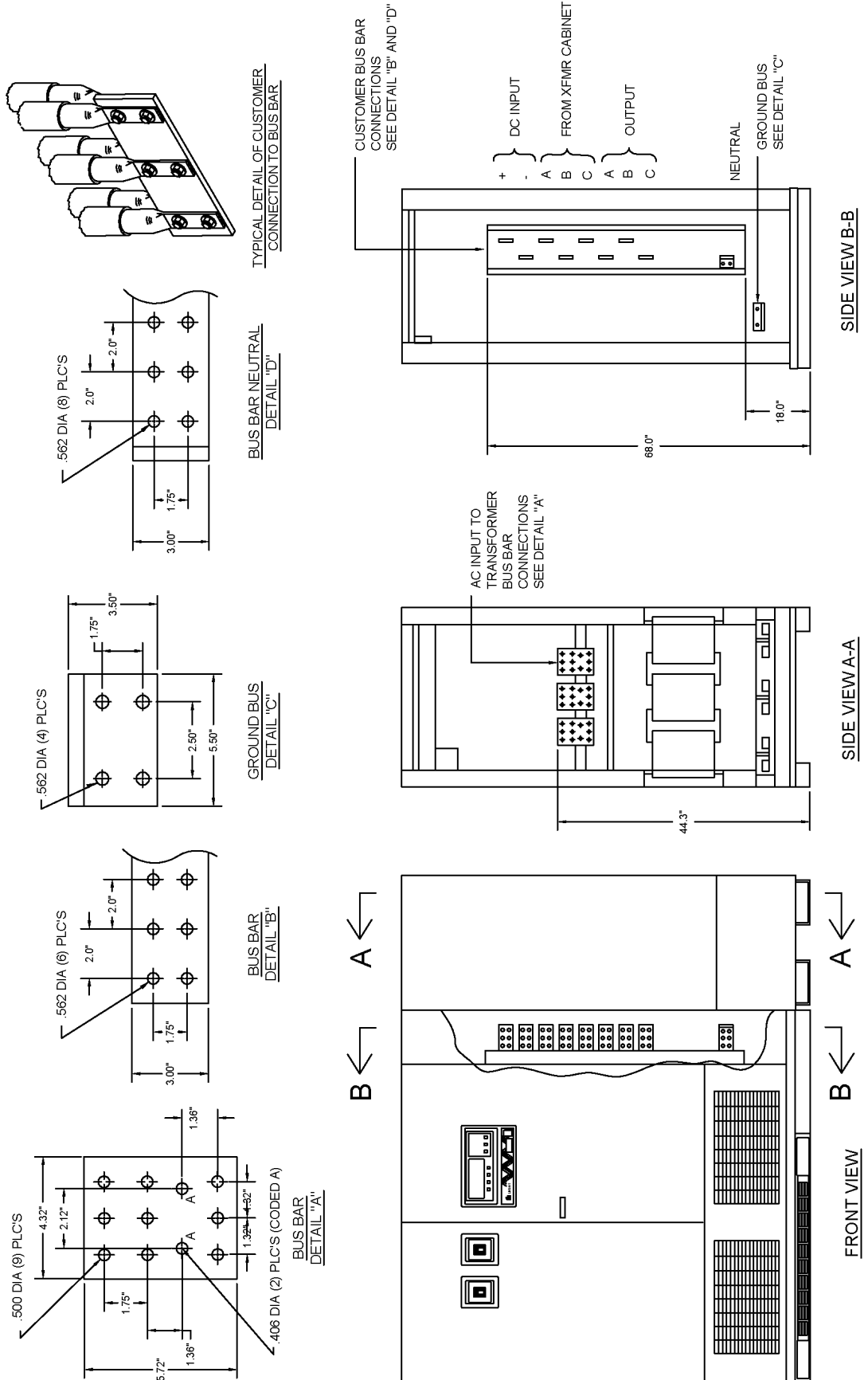

Figure 23 Terminal details, 400 & 450kVA Multi-Module UPS with input ISO transformer cabinet (optional)



NOTES:

1. LUGS FOR BUS BAR CONNECTION, PROVIDED BY OTHERS.
2. ALL DIMENSIONS ARE IN INCHES.

88-797638-95
Rev. 02

Figure 24 Base mounting patterns, 300-450kVA modules

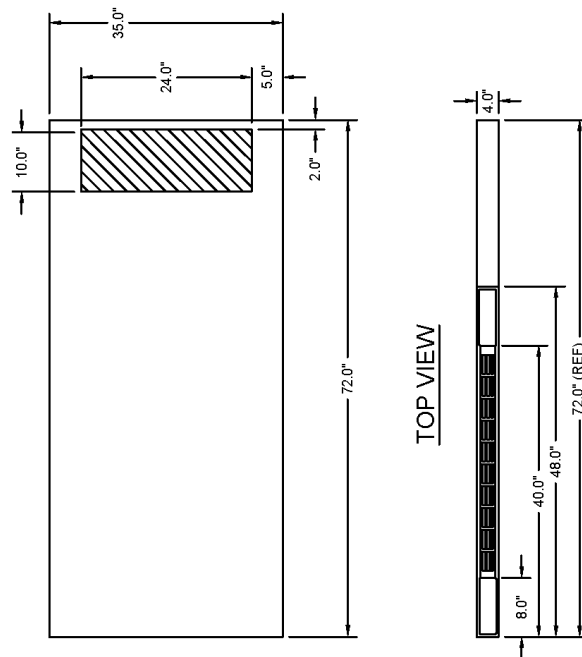

FRONT VIEW OF BASE (FORKLIFT ACCESS)

NOTES:

1. SHADED AREAS ON REMOVABLE PLATES INDICATE AVAILABLE LOCATIONS FOR BOTTOM ENTRY OF CUSTOMERS CABLES IF DESIRED.
2. THE REMOVABLE PLATES SHOWN ARE LOCATED APPROXIMATELY 4.0 INCHES FROM THE CABINET BASE MOUNTING SURFACE (e.g. CONCRETE FLOOR).
3. TOLERANCE ON ALL DIMENSIONS IS $\pm .25"$
4. ALL DIMENSIONS ARE IN INCHES.
5. ALL PATTERNS ARE TOP VIEW ONLY.

88-797613-15
Rev. 10

Figure 25 Line-up detail, 300-450kVA Multi-Module System with input isolation transformer cabinet

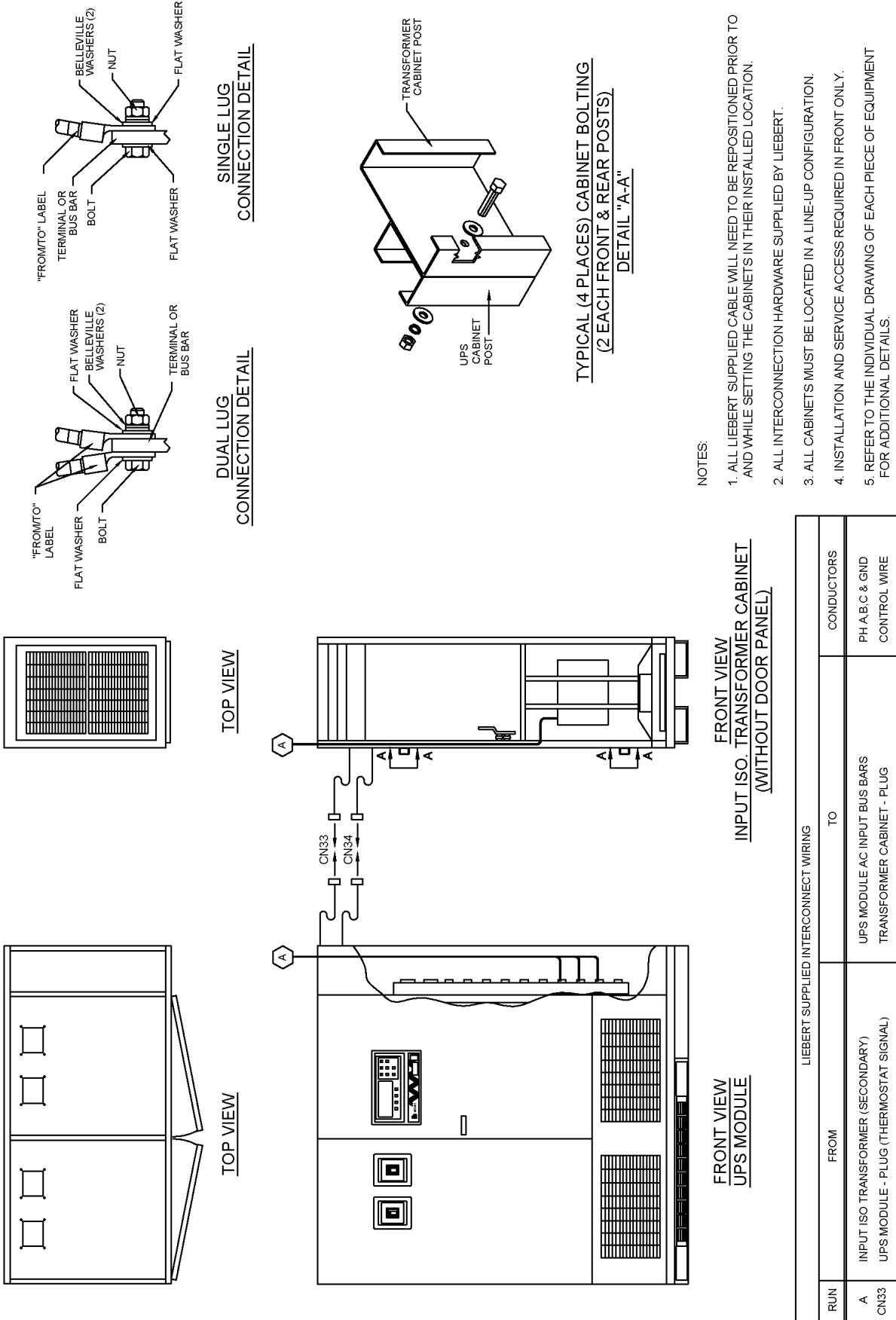

88-797607-64
Rev. 02

Figure 26 Battery power pack system

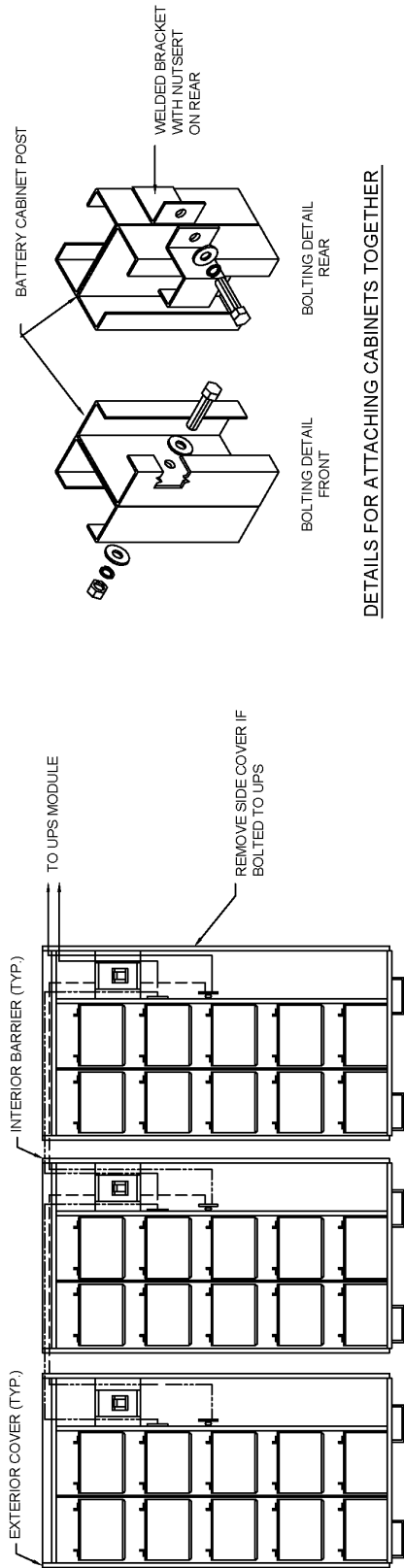

DETAILS FOR ATTACHING CABINETS TOGETHER

NOTES:

1. ALL CABLES SHOULD BE ROUTED BEFORE BOLTING CABINETS TOGETHER.
2. ALL CABINETS SHOWN WITH FRONT PANELS REMOVED.
3. BATTERY CABINETS SHOWN CONNECTED AS ONE SYSTEM. WHEN CONNECTED TO A UPS MODULE (100-225KVA) ALL CABLES PROVIDED. WHEN REMOTE FROM A UPS MODULE THE CABLES BETWEEN THE BATTERY CABINET AND THE UPS CABINET MUST BE SUPPLIED BY CUSTOMER.
4. ALL HARDWARE SUPPLIED WITH BATTERY CABINETS FOR BOLTING CABINETS TOGETHER.
5. USE 3/8-16 HARDWARE PROVIDED. ASSEMBLE AS SHOWN IN DETAIL DRAWING.
6. WHEN CONNECTED TO A UPS MODULE (100-225KVA). ENSURE THAT BATTERY CABINET "1" HAS THE HEAT BARRIER PANEL INSTALLED BETWEEN THE BATTERY CABINETS AND UPS.
7. SEE INSTALLATION, OPERATION AND MAINTENANCE MANUAL FOR ADDITIONAL INFORMATION.
8. ALL EXTERNAL WIRING IS TO BE IN ACCORDANCE WITH NATIONAL AND LOCAL ELECTRICAL CODES.

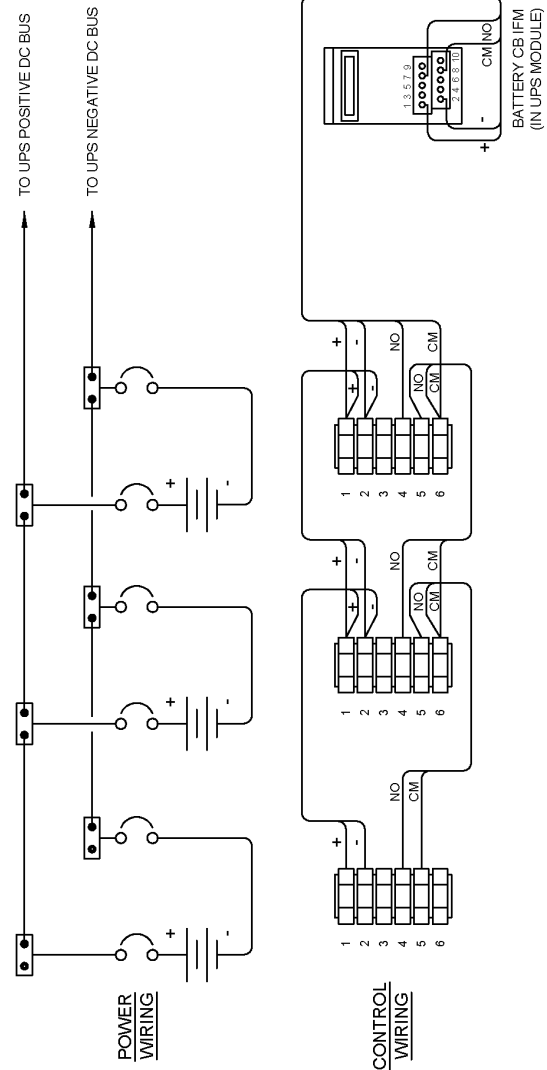

88-797616-03
Rev. 08

Figure 27 Battery power pack, Size A

- NOTES:
1. COLOR - IBM OFF-WHITE
 2. ALL DIMENSIONS ARE IN INCHES
 3. INSTALLATION AND SERVICE ACCESS REQUIRED IN FRONT. .38" (915 MM) MINIMUM.
 4. KEEP CABINET WITHIN 15° OF VERTICAL WHILE HANDLING.
 5. LIFT FROM BOTTOM ONLY.
 6. RECOMMENDED OPERATING TEMPERATURE RANGE: 20°C (68°F) TO 25°C (77°F).
 7. CONTROL AND POWER WIRING MUST BE RUN IN SEPARATE CONDUITS.
 8. ALL WIRING IS TO BE IN ACCORDANCE WITH NATIONAL AND LOCAL ELECTRICAL CODES.

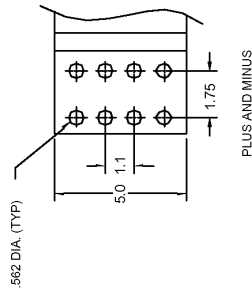

DETAIL FOR DC BUS BARS

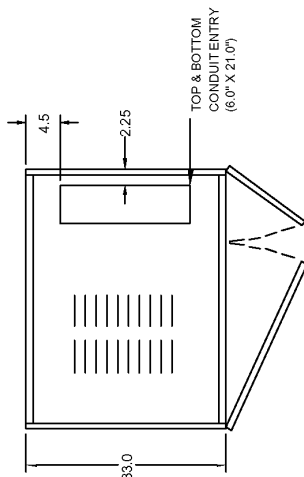

TOP VIEW

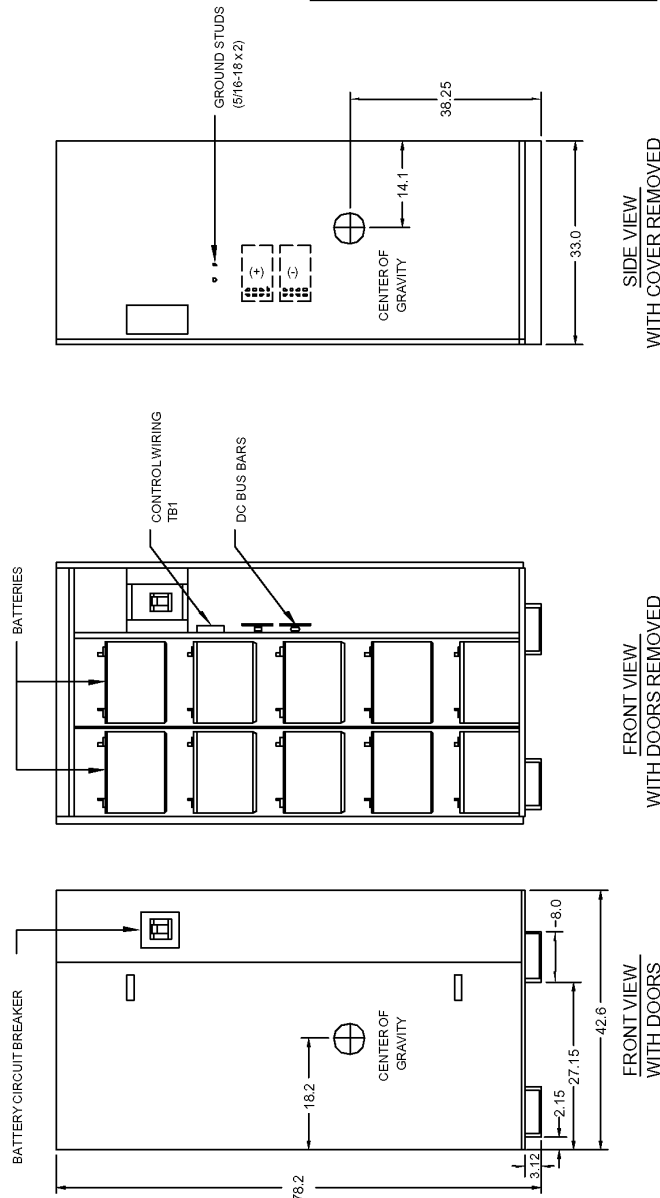

FRONT VIEW WITH DOORS

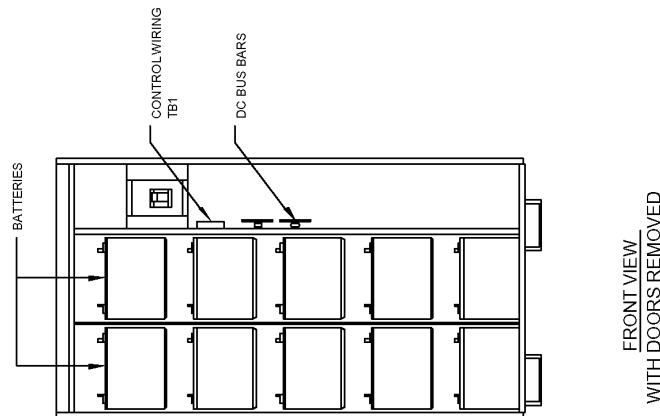

FRONT VIEW WITH DOORS REMOVED

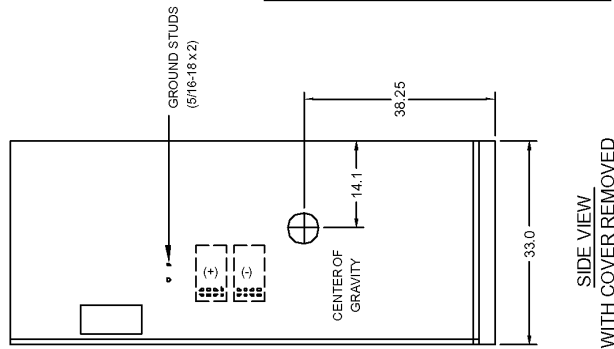

SIDE VIEW WITH COVER REMOVED

APPROXIMATE WEIGHTS

MODEL NUMBER	BATTERY TYPE	UNIT WEIGHT	
		LBS	KG
U36BP_MJ	UPS12-200	3050	1383
U36BP_RJ	UPS12-270	3060	1388
U36BP_RL	UP512-310	3380	1533
U36BP_RJ	UP512-370	3780	1715
U36BP_WJ	UP512-475	4900	2223
U36BP_XJ	UP512-530	4900	2223
U36BP_HL	L512-80	4100	1860
U36BP_NK	HX205-FR	3170	1438
U36BP_PX	HX300-FR	3180	1442
U36BP_RX	HX330-FR	3540	1606
U36BP_UX	HX400-FR	4120	1869
U36BP_WX	HX500-FR	5300	2404

88-797616-01
 Rev. 10

Figure 28 Line-up detail, 300-500kVA Single- or Multi-Module System with battery cabinets

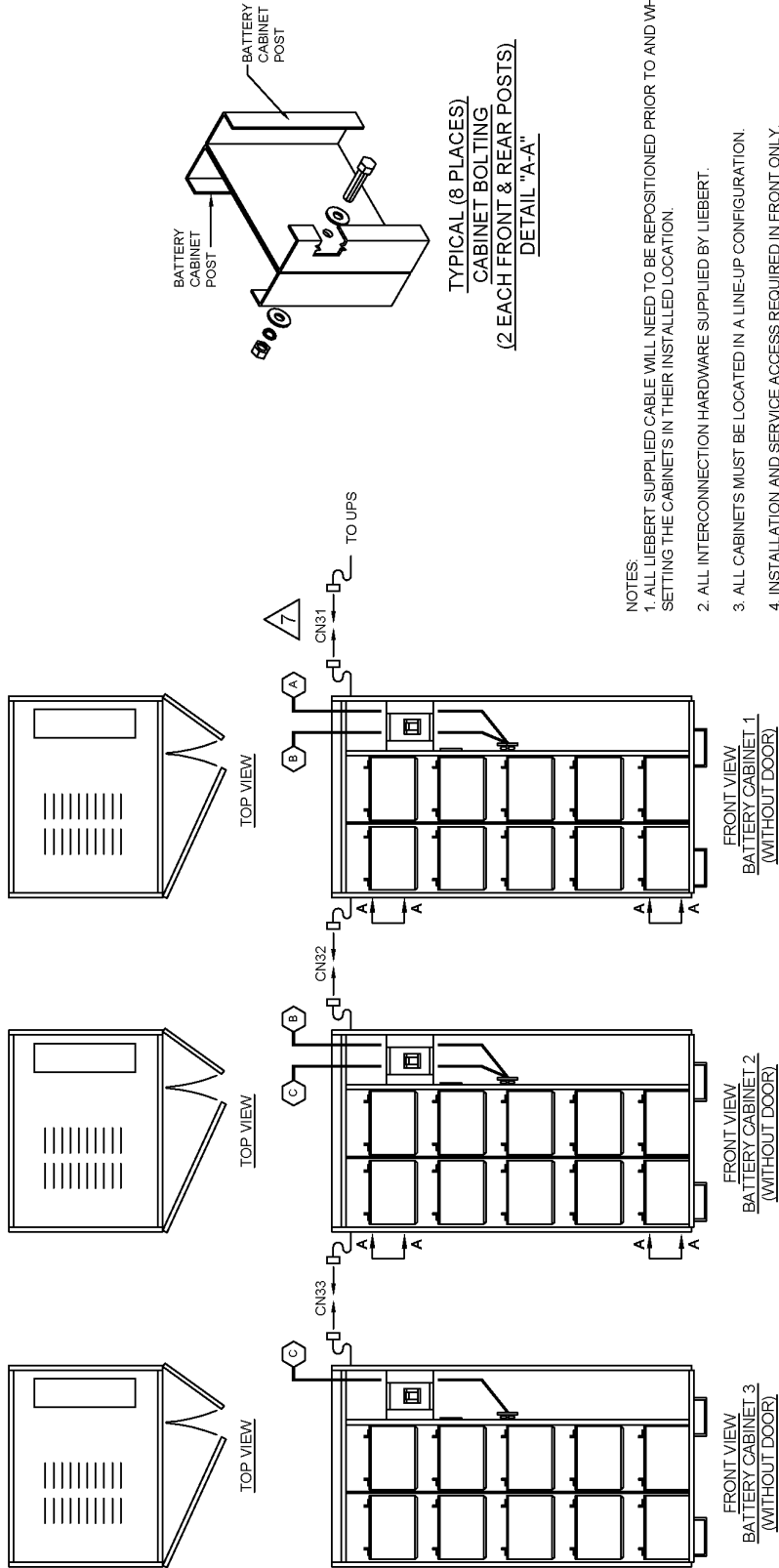

- NOTES:
1. ALL LIEBERT SUPPLIED CABLE WILL NEED TO BE REPOSITIONED PRIOR TO AND WHILE SETTING THE CABINETS IN THEIR INSTALLED LOCATION.
 2. ALL INTERCONNECTION HARDWARE SUPPLIED BY LIEBERT.
 3. ALL CABINETS MUST BE LOCATED IN A LINE-UP CONFIGURATION.
 4. INSTALLATION AND SERVICE ACCESS REQUIRED IN FRONT ONLY. 36" (915) MINIMUM.
 5. REFER TO THE INDIVIDUAL DRAWING OF EACH PIECE OF EQUIPMENT FOR ADDITIONAL DETAILS.
 6. ALL WIRING MUST BE IN ACCORDANCE WITH NATIONAL AND LOCAL ELECTRICAL CODES.
 7. WHEN IT HAS BEEN DETERMINED WHICH BATTERY CABINET WILL BE CABINET 1, DISCARD CABLE RUN (A) AND CONTROL WIRING CN31. THESE MUST BE RUN EXTERNALLY AND BE PROVIDED BY INSTALLER.
 8. ALL LIEBERT SUPPLIED WIRING TO BE RUN INTERNALLY.

LIEBERT SUPPLIED INTERCONNECT WIRING		CONDUCTORS
RUN	FROM	TO
B	BATTERY CABINET 1 - CONNECTION TERMINAL	POSITIVE/NEGATIVE
C	BATTERY CABINET 2 - CONNECTION TERMINAL	POSITIVE/NEGATIVE
CN32	BATTERY CABINET 1 - PLUG	CONTROL WIRE
CN33	BATTERY CABINET 2 - PLUG	CONTROL WIRE

88-797607-63
Rev. 04

Figure 29 Outline drawing, System Control Cabinet (SCCT), 200-1200A

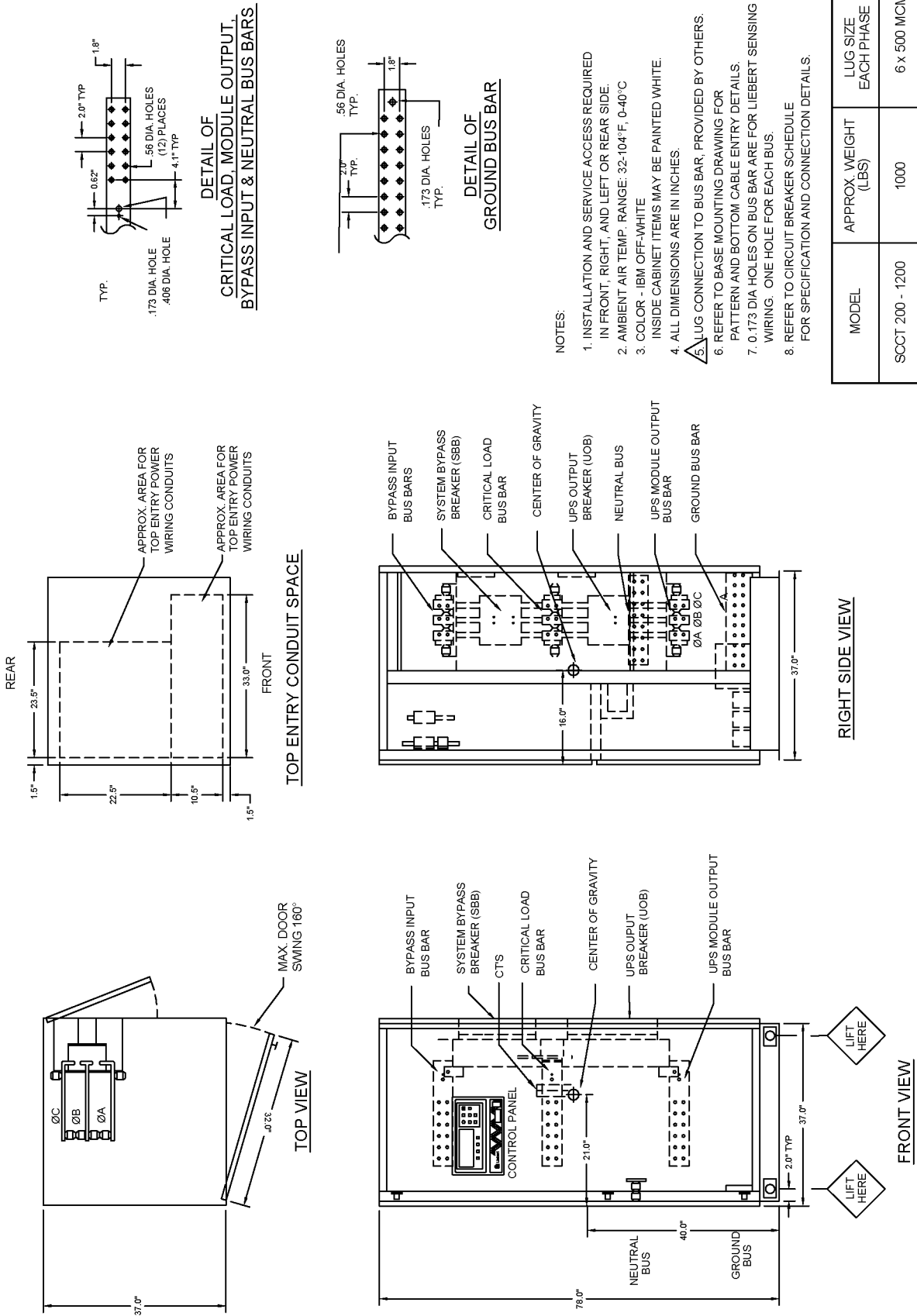

MODEL	APPROX. WEIGHT (LBS)	LUG SIZE EACH PHASE
SCCT 200 - 1200	1000	6 x 500 MCM

88-797614-01
 Rev. 08

Figure 30 Base mounting patterns, System Control Cabinet (SCCT), 200-1200A

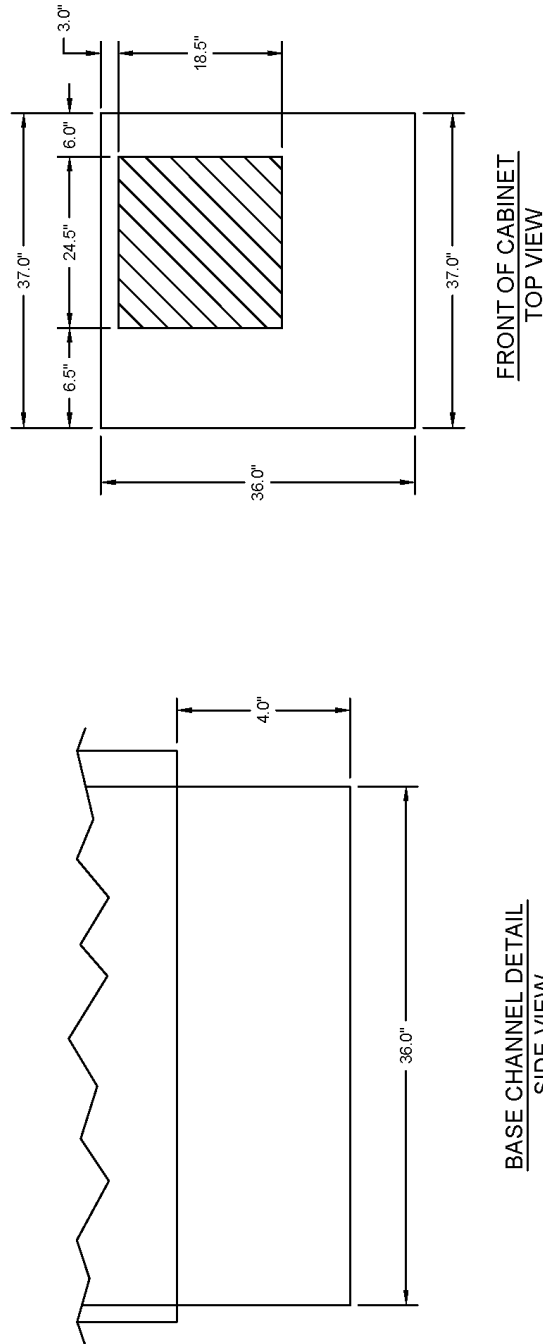

NOTES:

1. SHADED AREA INDICATES AVAILABLE LOCATION FOR BOTTOM ENTRY OF CUSTOMER CABLES IF DESIRED.
2. TOLERANCE ON ALL DIMENSIONS IS ± 0.25 INCHES
3. ALL DIMENSIONS ARE IN INCHES.

88-797613-71
Rev. 08

Figure 31 Outline drawing, System Control Cabinet (SCCT), 1600-2000A

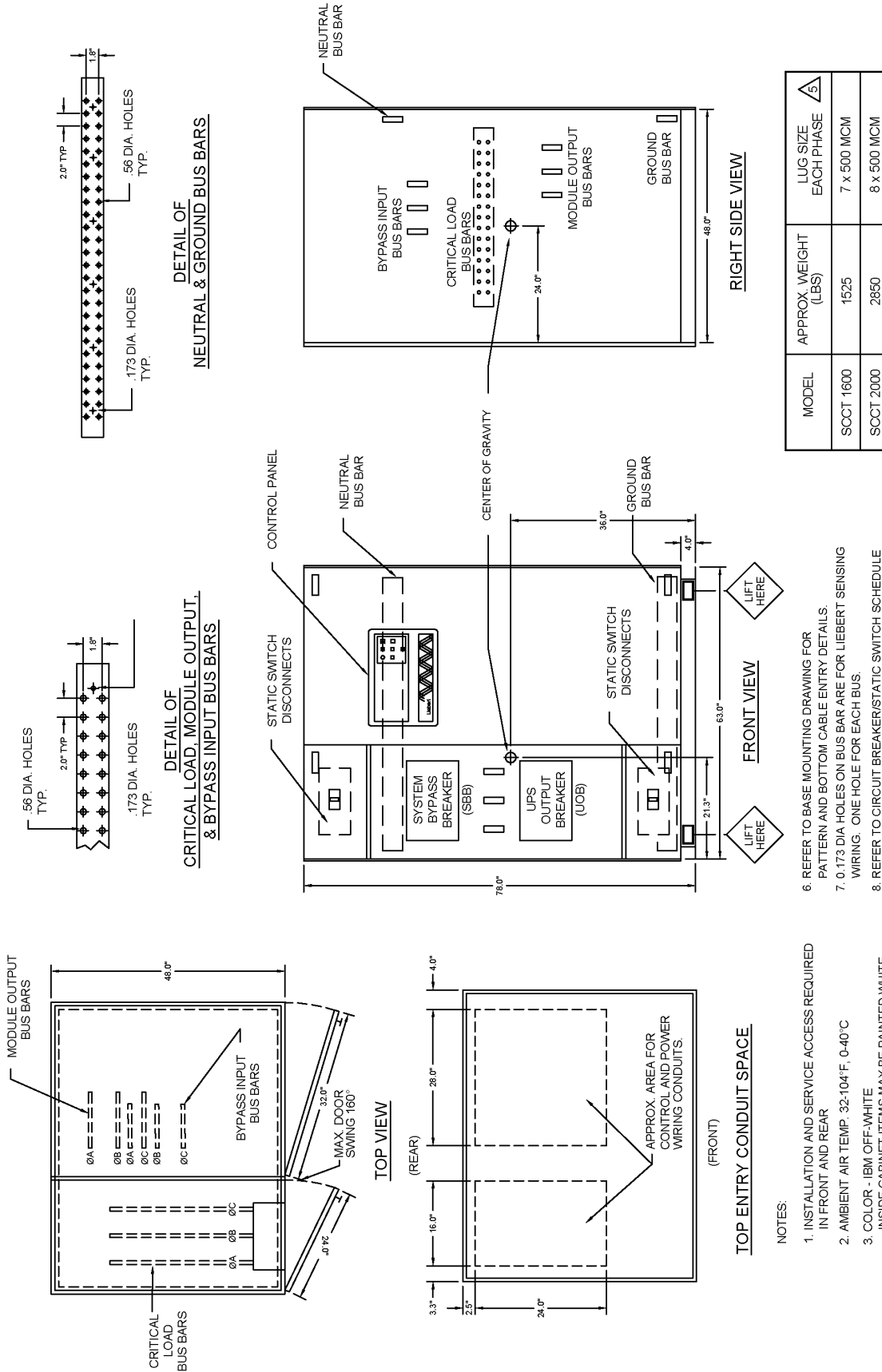

6. REFER TO BASE MOUNTING DRAWING FOR PATTERN AND BOTTOM CABLE ENTRY DETAILS.
7. 0.173 DIA HOLES ON BUS BAR ARE FOR LIEBERT SENSING WIRING. ONE HOLE FOR EACH BUS.
8. REFER TO CIRCUIT BREAKER/STATIC SWITCH SCHEDULE FOR SPECIFICATION AND CONNECTION DETAILS.

TOP ENTRY CONDUIT SPACE

NOTES:

1. INSTALLATION AND SERVICE ACCESS REQUIRED IN FRONT AND REAR
2. AMBIENT AIR TEMP. 32-104°F, 0-40°C
3. COLOR - IBM OFF-WHITE
INSIDE CABINET ITEMS MAY BE PAINTED WHITE.
4. ALL DIMENSIONS ARE IN INCHES.
5. LUG CONNECTION TO BUS BAR, PROVIDED BY OTHERS.

88-797614-02
Rev. 07

Figure 32 Base mounting patterns, System Control Cabinet (SCCT), 1600-2000A

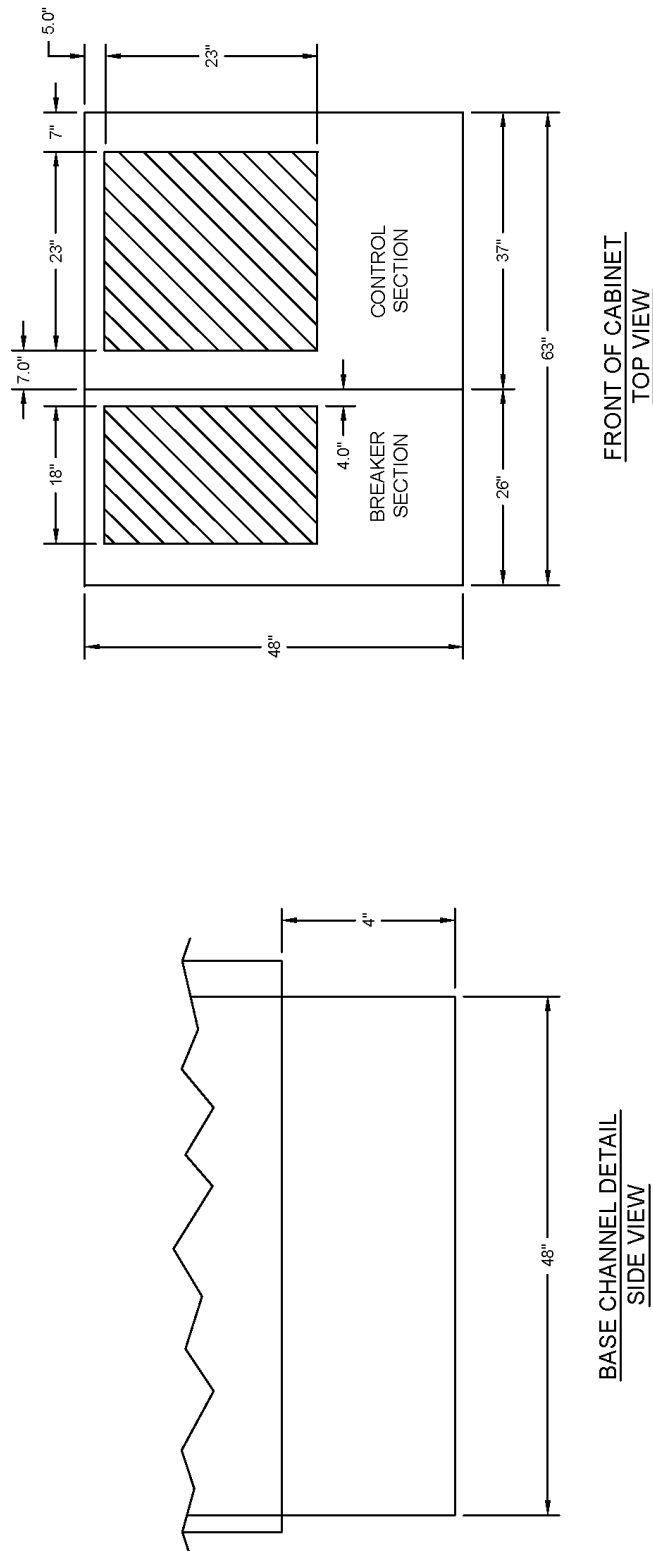

NOTES:

1. SHADED AREAS INDICATE AVAILABLE LOCATION FOR BOTTOM ENTRY OF CUSTOMER CABLES IF DESIRED.
2. TOLERANCE ON ALL DIMENSIONS IS ± 0.25 INCHES
3. ALL DIMENSIONS ARE IN INCHES.

88-797613-78
Rev. 07

Figure 33 Outline drawing, System Control Cabinet (SCCT), 2500-3000A

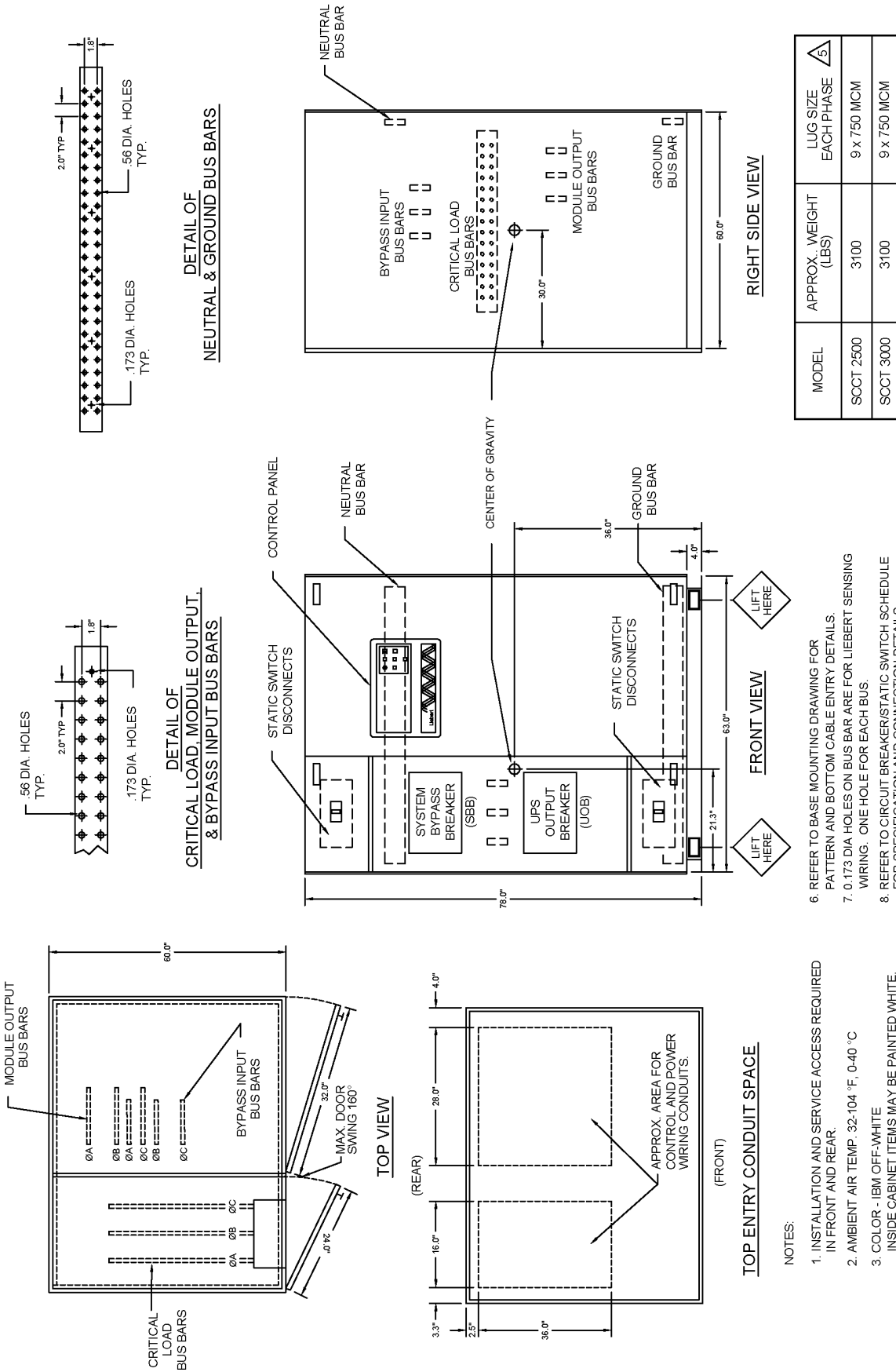

88-797614-03
Rev. 08

6. REFER TO BASE MOUNTING DRAWING FOR PATTERN AND BOTTOM CABLE ENTRY DETAILS.
7. 0.173 DIA HOLES ON BUS BAR ARE FOR LIEBERT SENSING WIRING. ONE HOLE FOR EACH BUS.
8. REFER TO CIRCUIT BREAKER/STATIC SWITCH SCHEDULE FOR SPECIFICATION AND CONNECTION DETAILS.

- NOTES:
1. INSTALLATION AND SERVICE ACCESS REQUIRED IN FRONT AND REAR.
 2. AMBIENT AIR TEMP. 32-104 °F, 0-40 °C
 3. COLOR - IBM OFF-WHITE
 4. ALL DIMENSIONS ARE IN INCHES.
- ▲ LUG CONNECTION TO BUS BAR, PROVIDED BY OTHERS.

Figure 34 Base mounting patterns, System Control Cabinet (SCCT), 2500-3000A

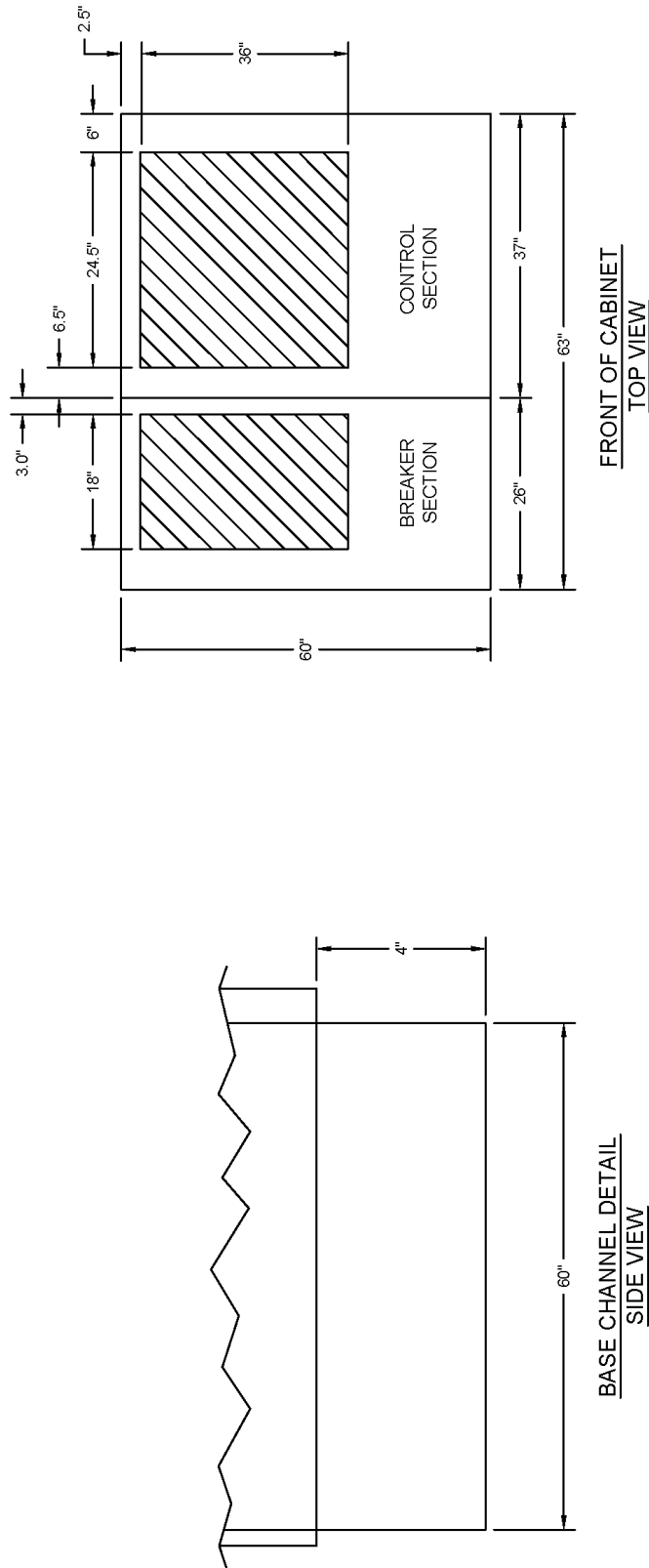

NOTES:

1. SHADED AREAS INDICATE AVAILABLE LOCATION FOR BOTTOM ENTRY OF CUSTOMER CABLES IF DESIRED.
2. TOLERANCE ON ALL DIMENSIONS IS ± 0.25 INCHES
3. ALL DIMENSIONS ARE IN INCHES.

88-797613-73
Rev. 06

Figure 35 Outline drawing, System Control Cabinet (SCCT), 4000A

NOTES:

1. INSTALLATION AND SERVICE ACCESS REQUIRED ON FRONT AND REAR. 36" (915) MINIMUM.
2. AMBIENT AIR TEMP. 32-104°F, 0-40°C
3. COLOR - IBM OFF-WHITE
INSIDE CABINET ITEMS MAY BE PAINTED WHITE.
4. ALL DIMENSIONS ARE IN INCHES.
5. LUG CONNECTION TO BUS BAR, PROVIDED BY OTHERS.
6. REFER TO BASE MOUNTING DRAWING 88-797613-72 FOR PATTERN AND BOTTOM CABLE ENTRY DETAILS.
7. 0.173 DIA HOLES ON BUS BAR ARE FOR LIEBERT SENSING WIRING. ONE HOLE FOR EACH BUS.
8. REFER TO CIRCUIT BREAKER/STATIC SWITCH SCHEDULE FOR SPECIFICATION AND CONNECTION DETAILS.

MODEL	APPROX. WEIGHT (LBS)	LUG SIZE EACH PHASE
SCCT 4000	5850	15 x 750 MCM

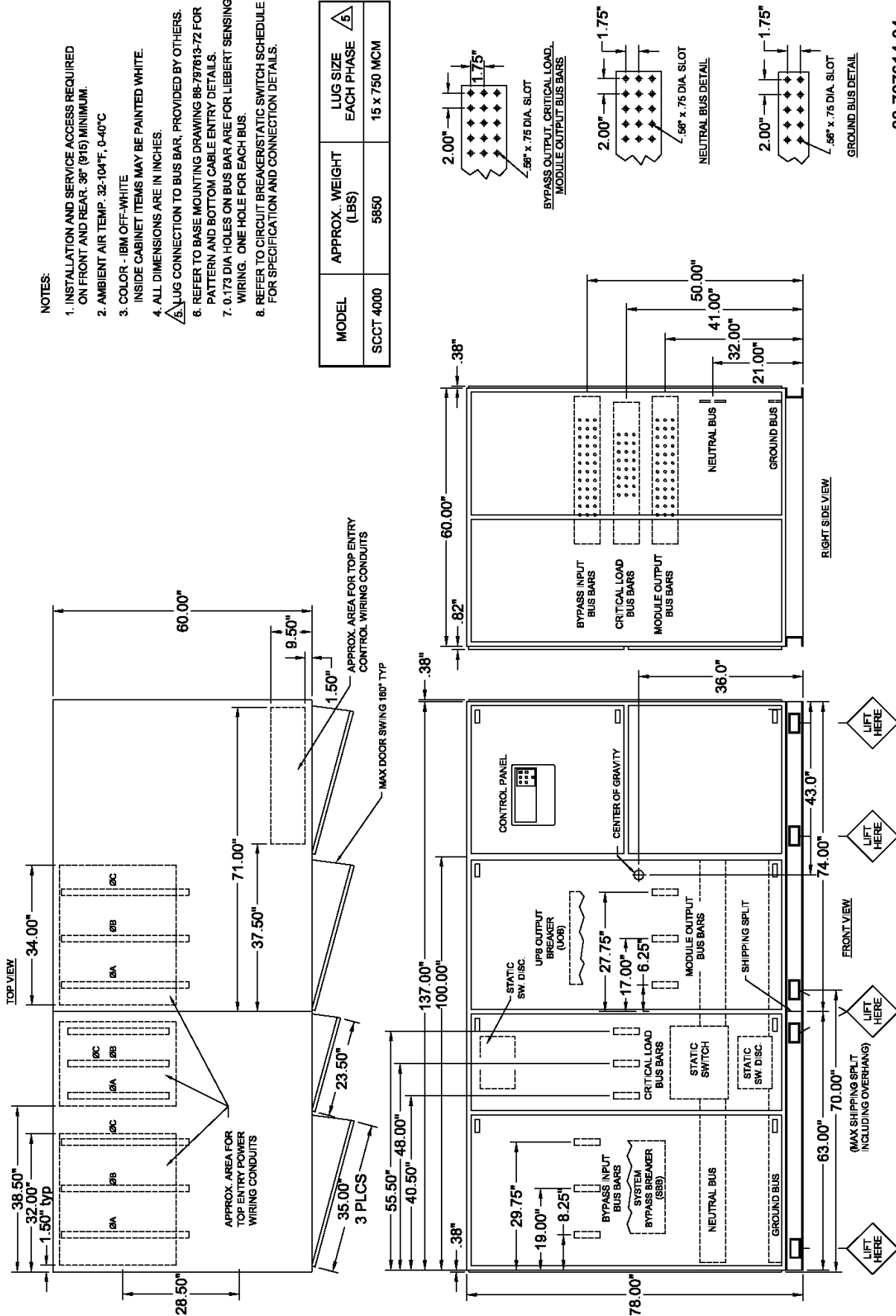
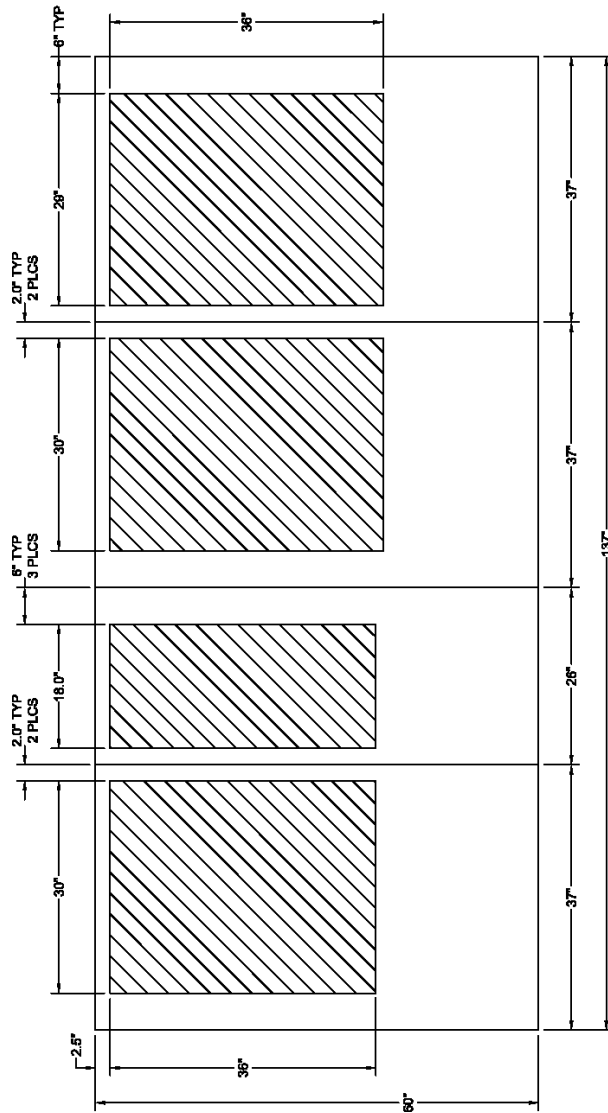
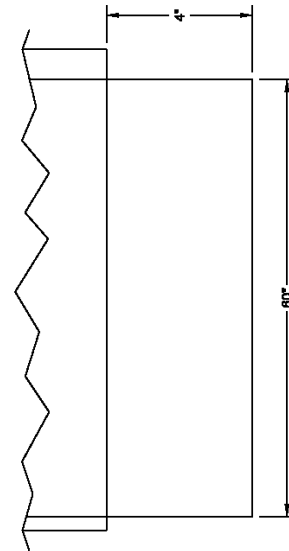

Figure 36 Base mounting patterns, System Control Cabinet (SCCT), 4000A



FRONT OF CABINET
TOP VIEW



BASE CHANNEL DETAIL
SIDE VIEW

- NOTES:
1. SHADED AREAS INDICATE AVAILABLE LOCATION FOR BOTTOM ENTRY OF CUSTOMER CABLES IF DESIRED.
 2. TOLERANCE ON ALL DIMENSIONS IS ± 0.25 INCHES.
 3. ALL DIMENSIONS ARE IN INCHES.

88-797613-72
Rev. 07

Figure 37 Control connection location diagram, Multi-Module System, 300-500kVA

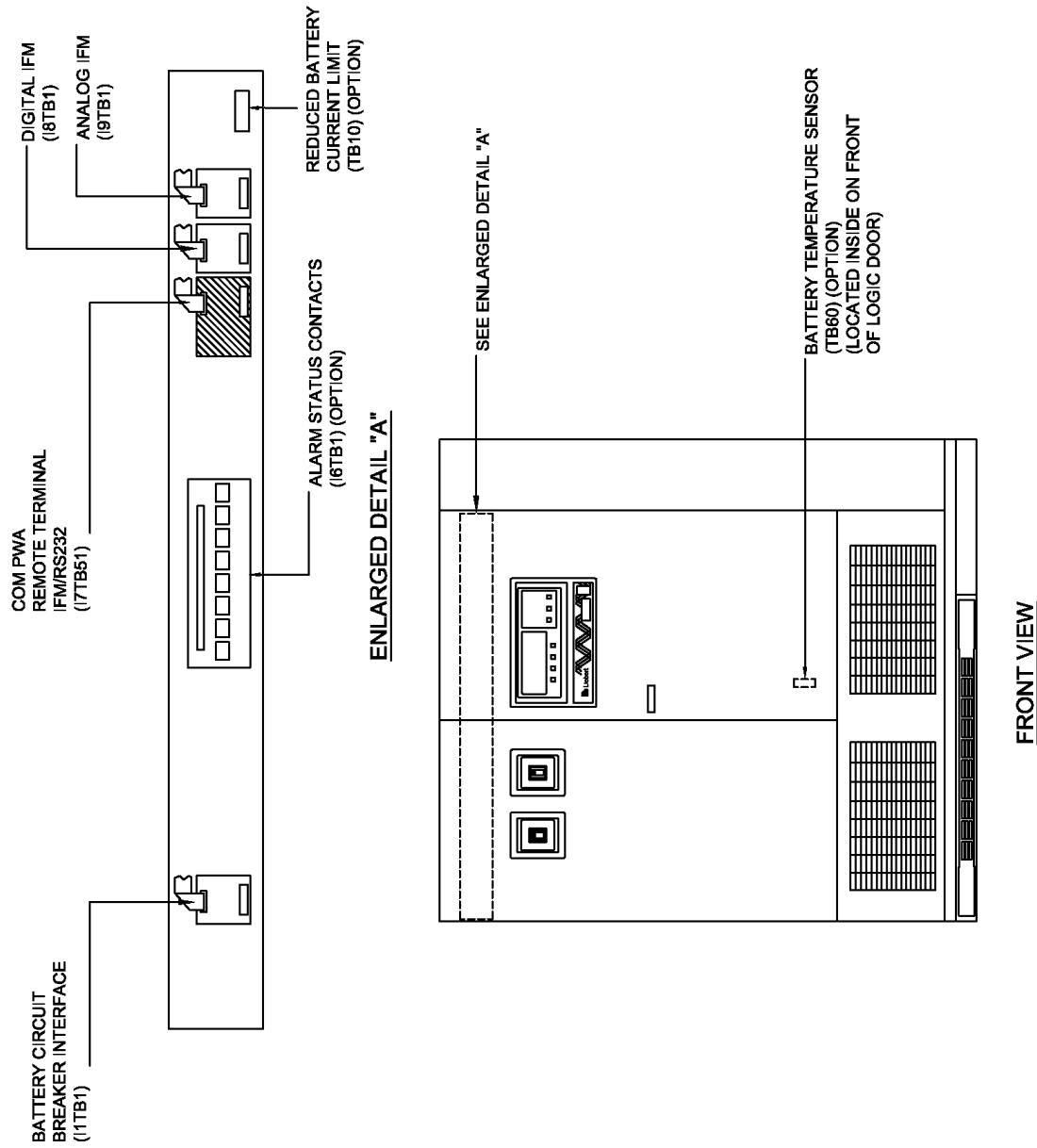

96-797619-58A
Rev. 03

Figure 38 Control connection location diagram, SCCT

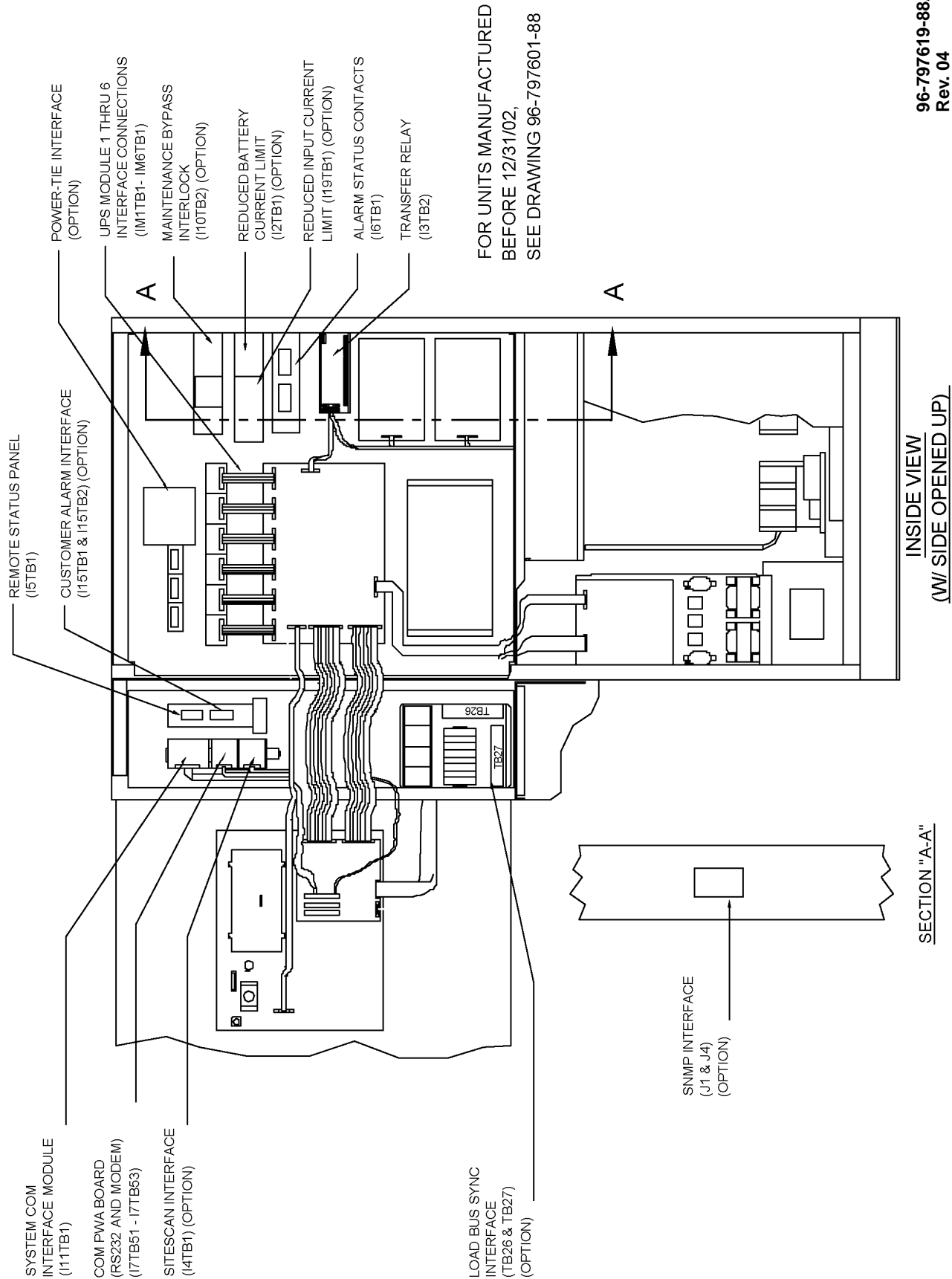

96-797619-88A
Rev. 04

Figure 39 Control wiring, external interconnect diagram, Multi-Module System

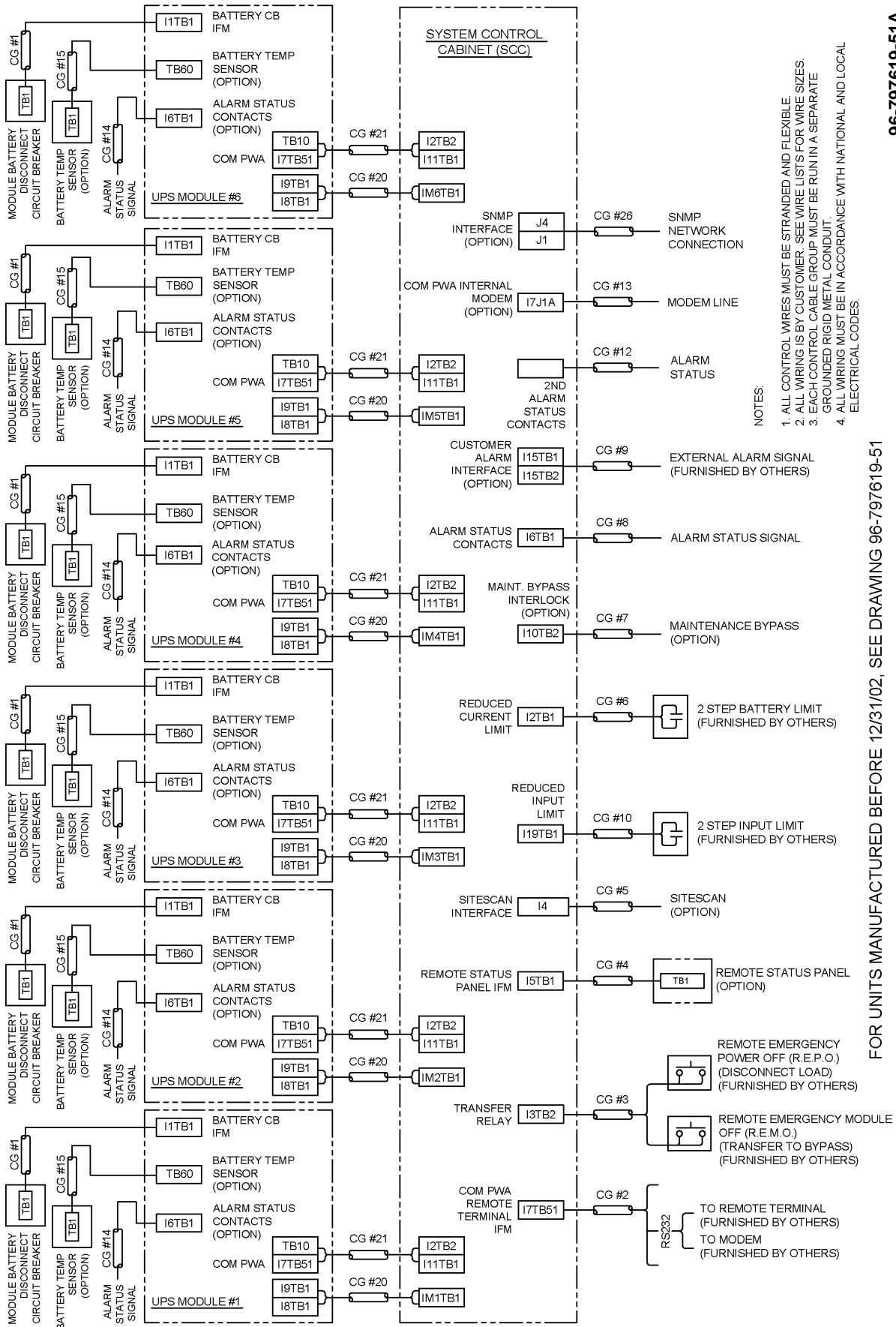

96-797619-51A
Rev. 03

Figure 40 Control wire list, external interconnections, standard wiring, Multi-Module System, UPS module, Cable Group #1

WIRE NO.	TERMINAL DESIGNATION		SIGNAL NAME	MAXIMUM VOLTAGE	MAXIMUM CURRENT	COLOR	WIRE SIZE & TYPE	MAX. LENGTH	REMARKS
	FROM	TO							
CABLE GROUP #1 (BATTERY CB IFM) FROM 11 IN UPS MODULE TO TB1 ON MODULE BATTERY DISCONNECT (MBD)									
901	11TB1-1	TB1-1	TRIP SIGNAL (+)	+ 24VDC	100mA				
902	11TB1-2	TB1-2	TRIP SIGNAL (-)	- 24VDC	100mA		1/C #14 (2.5 mmsq)	500 FT. (150 METERS)	
903	11TB1-7	TB1-7	AUX COMM.	24VDC	100mA				
904	11TB1-8	TB1-8	AUX N.O.	24VDC	100mA				

NOTES:

1. EACH CABLE GROUP MUST BE RUN IN A SEPARATE STEEL RACEWAY TO PREVENT CONTROL SIGNAL INTERFERENCE.
2. REFER TO UPS MODULE CONTROL CONNECTION LOCATION DIAGRAM FOR LOCATION OF WIRING CONNECTIONS.
3. FOR OPTION WIRING CONNECTIONS, REFER TO INDIVIDUAL CONTROL WIRE LISTS.
4. ALL EXTERNAL WIRE FURNISHED BY OTHERS.
5. N.O. = NORMALLY OPEN, COMM. = COMMON.
6. ALL WIRING MUST BE IN ACCORDANCE WITH NATIONAL AND LOCAL ELECTRICAL CODES.

96-797619-60
Rev. 06

Figure 41 Control wire list, external interconnections, standard wiring, Multi-Module System, System Control Cabinet, Part 1 of 3, Cable Groups #2 & #3

WIRE NO.	TERMINAL DESIGNATION		SIGNAL NAME	MAXIMUM VOLTAGE	MAXIMUM CURRENT	COLOR	WIRE SIZE & TYPE	MAX. LENGTH	REMARKS
	FROM	TO							
CABLE GROUP #2 (COM PWA) FROM I7 IN SYSTEM CONTROL CABINET TO CUSTOMER CONNECTION (F.B.O)									
700	I7TB51-1	F.B.O.	REM. TERM. TXD	24VDC	100mA		3/C #22 (0.50 mmsq) TWISTED SHIELDED	100 FT. (30 METERS)	COM PWA 02-810015-10
701	I7TB51-2	F.B.O.	REM. TERM. RXD	24VDC	100mA				
702	I7TB51-3	F.B.O.	REM. TERM. GND	24VDC	100mA				
---	I7E1	F.B.O.	REM. TERM. SHD	24VDC	100mA				
703	I7TB52-1	F.B.O.	MODEM DCD	24VDC	100mA				
704	I7TB52-3	F.B.O.	MODEM TXD	24VDC	100mA				
705	I7TB52-2	F.B.O.	MODEM RXD	24VDC	100mA				
706	I7TB53-2	F.B.O.	MODEM GND	24VDC	100mA				
---	I7E1	F.B.O.	MODEM SHD	24VDC	100mA				
CABLE GROUP #3 (TRANSFER RELAY) FROM I3 IN SYSTEM CONTROL CABINET TO R.E.M.O. & R.E.P.O.									
711	I3TB2-1	N.O.	REMOTE EMER. MOD. OFF	24VDC	1A		1/C #14 (2.5 mmsq)	500 FT. (150 METERS)	
712	I3TB2-2	COMM.	REMOTE EMER. MOD. OFF	24VDC	1A				
713	I3TB2-3	N.O.	REMOTE EMER. POWER OFF	24VDC	1A				
714	I3TB2-4	COMM.	REMOTE EMER. POWER OFF	24VDC	1A				

NOTES:

1. EACH CABLE GROUP MUST BE RUN IN A SEPARATE GROUNDED RIGID METAL CONDUIT TO PREVENT CONTROL SIGNAL INTERFERENCE.
2. CABLE GROUP #2 AND #5 MAY BE RUN IN THE SAME CONDUIT.
3. REFER TO SCC CONTROL CONNECTION LOCATION DIAGRAM FOR LOCATION OF WIRING CONNECTIONS.
4. FOR OPTION WIRING CONNECTIONS, REFER TO INDIVIDUAL CONTROL WIRE LISTS.
5. F.B.O. - FURNISHED BY OTHERS.
6. ALL EXTERNAL WIRE FURNISHED BY OTHERS.
7. N.O. = NORMALLY OPEN, COMM. = COMMON.
8. ALL WIRING MUST BE IN ACCORDANCE WITH NATIONAL AND LOCAL ELECTRICAL CODES.

FOR UNITS MANUFACTURED BEFORE 12/31/02, SEE DRAWING 96-797619-19

96-797619-19A
Rev. 03

Figure 42 Control wire list, external interconnections, standard wiring, Multi-Module System, System Control Cabinet, Part 2 of 3, Cable Groups #5 & #6

WIRE NO.	TERMINAL DESIGNATION		SIGNAL NAME	MAXIMUM VOLTAGE	MAXIMUM CURRENT	COLOR	WIRE SIZE & TYPE	MAX. LENGTH	REMARKS
	FROM	TO							
CABLE GROUP #5 (SITESCAN INTERFACE BOARD) FROM I4 IN SYSTEM CONTROL CABINET TO OPTIONAL SITESCAN									
741	I4TB1-1	SITESCAN	SITESCAN SCC (+)	5VDC	10mA	BLACK	2/C #22 (0.50 mm ²) TWISTED PAIR	1000 FT. (300 METERS)	BELDEN 8761 OR EQUAL SEE NOTE 2
742	I4TB1-2	SITESCAN	SITESCAN SCC (-)	5VDC	10mA	CLEAR			
743	I4TB1-3	SITESCAN	SITESCAN MOD1 (+)	5VDC	10mA	BLACK			
744	I4TB1-4	SITESCAN	SITESCAN MOD1 (-)	5VDC	10mA	CLEAR			
745	I4TB1-5	SITESCAN	SITESCAN MOD2 (+)	5VDC	10mA	BLACK			
746	I4TB1-6	SITESCAN	SITESCAN MOD2 (-)	5VDC	10mA	CLEAR			
747	I4TB1-7	SITESCAN	SITESCAN MOD3 (+)	5VDC	10mA	BLACK			
748	I4TB1-8	SITESCAN	SITESCAN MOD3 (-)	5VDC	10mA	CLEAR			
749	I4TB1-9	SITESCAN	SITESCAN MOD4 (+)	5VDC	10mA	BLACK			
750	I4TB1-10	SITESCAN	SITESCAN MOD4 (-)	5VDC	10mA	CLEAR			
751	I4TB1-11	SITESCAN	SITESCAN MOD5 (+)	5VDC	10mA	BLACK			
752	I4TB1-12	SITESCAN	SITESCAN MOD5 (-)	5VDC	10mA	CLEAR			
753	I4TB1-13	SITESCAN	SITESCAN MOD6 (+)	5VDC	10mA	BLACK			
754	I4TB1-14	SITESCAN	SITESCAN MOD6 (-)	5VDC	10mA	CLEAR			
CABLE GROUP #6 (BATTERY CURRENT LIMIT) FROM I2 IN SYSTEM CONTROL CABINET TO CUSTOMER CONNECTION (F.B.O.)									
761	I2TB1-3	N.O.	2 STEP BATTERY LIMIT	24VDC	100mA		1/C #14 (2.5 mm ²)	500 FT. (150 METERS)	
762	I2TB1-4	COMM.	2 STEP BATTERY LIMIT	24VDC	100mA				

NOTES:

1. EACH CABLE GROUP MUST BE RUN IN A SEPARATE STEEL RACEWAY TO PREVENT CONTROL SIGNAL INTERFERENCE.
2. CABLE GROUP #2 AND #5 MAY BE RUN IN THE SAME CONDUIT.
3. REFER TO SCC CONTROL CONNECTION LOCATION DIAGRAM FOR LOCATION OF WIRING CONNECTIONS.
4. FOR OPTION WIRING CONNECTIONS, REFER TO INDIVIDUAL CONTROL WIRE LISTS.
5. F.B.O. - FURNISHED BY OTHERS.
6. ALL EXTERNAL WIRE FURNISHED BY OTHERS.
7. N.O. = NORMALLY OPEN, COMM. = COMMON.
8. ALL WIRING MUST BE IN ACCORDANCE WITH NATIONAL AND LOCAL ELECTRICAL CODES.

96-797619-20
Rev. 06

Figure 43 Control wire list, external interconnections, standard wiring, Multi-Module System, System Control Cabinet, Part 3 of 3, Cable Group #8

WIRE NO.	TERMINAL DESIGNATION		SIGNAL NAME	MAXIMUM VOLTAGE	MAXIMUM CURRENT	COLOR	WIRE SIZE & TYPE	MAX. LENGTH	REMARKS
	FROM	TO							
CABLE GROUP #8 (ALARM STATUS CONTACTS) FROM I6 IN SYSTEM CONTROL CABINET TO CUSTOMER CONNECTION (F.B.O.)									
801	I6TB1-1	N.O.	LOAD ON UPS	125VAC	500mA				
802	I6TB1-3	N.C.	LOAD ON UPS	125VAC	500mA				
803	I6TB1-5	COMM.	LOAD ON UPS	125VAC	500mA				
804	I6TB1-7	N.O.	LOAD ON BYPASS	125VAC	500mA				
805	I6TB1-9	N.C.	LOAD ON BYPASS	125VAC	500mA				
806	I6TB1-11	COMM.	LOAD ON BYPASS	125VAC	500mA				
807	I6TB1-13	N.O.	BATTERY DISCHARGING	125VAC	500mA				
808	I6TB1-15	N.C.	BATTERY DISCHARGING	125VAC	500mA				
809	I6TB1-17	COMM.	BATTERY DISCHARGING	125VAC	500mA				
810	I6TB1-19	N.O.	LOW BATTERY WARNING	125VAC	500mA				
811	I6TB1-21	N.C.	LOW BATTERY WARNING	125VAC	500mA				
812	I6TB1-23	COMM.	LOW BATTERY WARNING	125VAC	500mA				
813	I6TB1-25	N.O.	OVERLOAD	125VAC	500mA		1/C #14 (2.5 mm ²)	500 FT. (150 METERS)	SEE NOTE 2
814	I6TB1-27	N.C.	OVERLOAD	125VAC	500mA				
815	I6TB1-29	COMM.	OVERLOAD	125VAC	500mA				
816	I6TB1-31	N.O.	AMBIENT OVERTEMP	125VAC	500mA				
817	I6TB1-33	N.C.	AMBIENT OVERTEMP	125VAC	500mA				
818	I6TB1-35	COMM.	AMBIENT OVERTEMP	125VAC	500mA				
819	I6TB1-37	N.O.	SYSTEM SUMMARY ALARM	125VAC	500mA				
820	I6TB1-39	N.C.	SYSTEM SUMMARY ALARM	125VAC	500mA				
821	I6TB1-41	COMM.	SYSTEM SUMMARY ALARM	125VAC	500mA				
822	I6TB1-43	N.O.	NEW ALARM	125VAC	500mA				
823	I6TB1-45	N.C.	NEW ALARM	125VAC	500mA				
824	I6TB1-47	COMM.	NEW ALARM	125VAC	500mA				

NOTES:

- EACH CABLE GROUP MUST BE RUN IN A SEPARATE STEEL RACEWAY TO PREVENT CONTROL SIGNAL INTERFERENCE.
- CABLE GROUP #8 AND #14 MAY BE RUN IN THE SAME CONDUIT.
- REFER TO SCC CONTROL CONNECTION LOCATION DIAGRAM FOR LOCATION OF WIRING CONNECTIONS.
- FOR OPTION WIRING CONNECTIONS, REFER TO INDIVIDUAL CONTROL WIRE LISTS.
- F.B.O. - FURNISHED BY OTHERS.
- ALL EXTERNAL WIRE FURNISHED BY OTHERS.
- N.O. = NORMALLY OPEN; N.C. = NORMALLY CLOSED; COMM. = COMMON.
- ALL WIRING MUST BE IN ACCORDANCE WITH NATIONAL AND LOCAL ELECTRICAL CODES.
- SYSTEM "A" SHOWN; REPEAT FOR SYSTEM "B"

96-797619-21
Rev. 06

Figure 44 Control wire list, external interconnections, Multi-Module System, remote status panel option, Cable Group #4

WIRE NO.	TERMINAL DESIGNATION		SIGNAL NAME	MAXIMUM VOLTAGE	MAXIMUM CURRENT	COLOR	WIRE SIZE & TYPE	MAX. LENGTH	REMARKS
	FROM	TO							
CABLE GROUP #4 FROM I5 IN SYSTEM CONTROL CABINET TO TB1 IN OPTIONAL REMOTE STATUS PANEL									
721	I5TB1-1	TB1-1	LOAD ON UPS	24VDC	1 A		1/C #14 (2.5 mm ²)	500 FT. (150 METERS)	
722	I5TB1-2	TB1-2	LOAD ON BYPASS	24VDC	1 A				
723	I5TB1-3	TB1-3	BATTERY DISCHARGING	24VDC	1 A				
724	I5TB1-4	TB1-4	LOW BATTERY WARNING	24VDC	1 A				
725	I5TB1-5	TB1-5	OVERLOAD	24VDC	1 A				
726	I5TB1-6	TB1-6	AMBIENT OVERTEMP	24VDC	1 A				
727	I5TB1-7	TB1-7	SYSTEM SUMMARY ALARM	24VDC	1 A				
728	I5TB1-8	TB1-8	NEW ALARM	24VDC	1 A				
729	I5TB1-9	TB1-9	+ 24 VDC	24VDC	1 A				
730	I5TB1-10	TB1-10	GROUND	24VDC	1 A				

NOTES:

1. EACH CABLE GROUP MUST BE RUN IN A SEPARATE STEEL RACEWAY TO PREVENT CONTROL SIGNAL INTERFERENCE.
2. REFER TO SCC CONTROL CONNECTION LOCATION DIAGRAM FOR LOCATION OF WIRING CONNECTIONS.
3. ALL EXTERNAL WIRE FURNISHED BY OTHERS.
4. ALL WIRING MUST BE IN ACCORDANCE WITH NATIONAL AND LOCAL ELECTRICAL CODES.
5. UPS-A SHOWN, REPEAT FOR UPS-B

96-797619-130
Rev. 03

Figure 45 Control wire list, external interconnections, Multi-Module System (SCC with momentary duty static switch), customer alarm interface option, Cable Group #9

WIRE NO.	TERMINAL DESIGNATION		SIGNAL NAME	MAXIMUM VOLTAGE	MAXIMUM CURRENT	COLOR	WIRE SIZE & TYPE	MAX. LENGTH	REMARKS
	FROM	TO							
CABLE GROUP #9 FROM 115 TB1 & TB2 IN SYSTEM CONTROL CABINET TO CUSTOMER CONNECTION (F.B.O.)									
781	115TB1-1	N.O.	PROGRAMMABLE (ALARM #1)	24VDC	100mA		1/C #14 (2.5 mm ² sq) 500 FT. (150 METERS)		
782	115TB1-2	COMM.	PROGRAMMABLE (ALARM #1)	24VDC	100mA				
783	115TB1-3	N.O.	PROGRAMMABLE (ALARM #2)	24VDC	100mA				
784	115TB1-4	COMM.	PROGRAMMABLE (ALARM #2)	24VDC	100mA				
785	115TB1-5	N.O.	PROGRAMMABLE (ALARM #3)	24VDC	100mA				
786	115TB1-6	COMM.	PROGRAMMABLE (ALARM #3)	24VDC	100mA				
787	115TB1-7	N.O.	PROGRAMMABLE (ALARM #4)	24VDC	100mA				
788	115TB1-8	COMM.	PROGRAMMABLE (ALARM #4)	24VDC	100mA				
789	115TB1-9	N.O.	PROGRAMMABLE (ALARM #5)	24VDC	100mA				
790	115TB1-10	COMM.	PROGRAMMABLE (ALARM #5)	24VDC	100mA				
791	115TB2-1	N.O.	PROGRAMMABLE (ALARM #6)	24VDC	100mA				
792	115TB2-2	COMM.	PROGRAMMABLE (ALARM #6)	24VDC	100mA				
793	115TB2-3	N.O.	PROGRAMMABLE (ALARM #7)	24VDC	100mA				
794	115TB2-4	COMM.	PROGRAMMABLE (ALARM #7)	24VDC	100mA				
795	115TB2-5	N.O.	PROGRAMMABLE (ALARM #8)	24VDC	100mA				
796	115TB2-6	COMM.	PROGRAMMABLE (ALARM #8)	24VDC	100mA				

NOTES:

1. EACH CABLE GROUP MUST BE RUN IN A SEPARATE STEEL RACEWAY TO PREVENT CONTROL SIGNAL INTERFERENCE.
2. REFER TO SCC CONTROL CONNECTION LOCATION DIAGRAM FOR LOCATION OF WIRING CONNECTIONS.
3. F.B.O. - FURNISHED BY OTHERS.
4. ALL EXTERNAL WIRE FURNISHED BY OTHERS.
5. N.C. = NORMALLY OPEN, COMM. = COMMON.
6. ALL WIRING MUST BE IN ACCORDANCE WITH NATIONAL AND LOCAL ELECTRICAL CODES.

96-797619-28
Rev. 06

Figure 46 Control wire list, external interconnections, Multi-Module System, alarm status contacts option, Cable Group #14

WIRE NO.	TERMINAL DESIGNATION		SIGNAL NAME	MAXIMUM VOLTAGE	MAXIMUM CURRENT	COLOR	WIRE SIZE & TYPE	MAX. LENGTH	REMARKS
	FROM	TO							
CABLE GROUP #14 FROM I6 IN UPS MODULE TO CUSTOMER CONNECTION (F.B.O.)									
910	I6TB2-22	N.O.	OUTPUT CB OPEN	125VAC	500mA				
911	I6TB2-24	N.C.	OUTPUT CB OPEN	125VAC	500mA				
912	I6TB2-23	COMM.	OUTPUT CB OPEN	125VAC	500mA				
913	I6TB2-19	N.O.	BATTERY CB OPEN	125VAC	500mA				
914	I6TB2-21	N.C.	BATTERY CB OPEN	125VAC	500mA				
915	I6TB2-20	COMM.	BATTERY CB OPEN	125VAC	500mA				
916	I6TB2-16	N.O.	BATTERY DISCHARGING	125VAC	500mA				
917	I6TB2-18	N.C.	BATTERY DISCHARGING	125VAC	500mA				
918	I6TB2-17	COMM.	BATTERY DISCHARGING	125VAC	500mA				
919	I6TB2-13	N.O.	LOW BATTERY WARNING	125VAC	500mA				
920	I6TB2-15	N.C.	LOW BATTERY WARNING	125VAC	500mA				
921	I6TB2-14	COMM.	LOW BATTERY WARNING	125VAC	500mA				
922	I6TB2-10	N.O.	CONTROL FAILURE	125VAC	500mA				
923	I6TB2-12	N.C.	CONTROL FAILURE	125VAC	500mA				
924	I6TB2-11	COMM.	CONTROL FAILURE	125VAC	500mA				
925	I6TB2-7	N.O.	AMBIENT OVERTEMP	125VAC	500mA				
926	I6TB2-9	N.C.	AMBIENT OVERTEMP	125VAC	500mA				
927	I6TB2-8	COMM.	AMBIENT OVERTEMP	125VAC	500mA				
928	I6TB2-4	N.O.	MODULE SUMMARY ALARM	125VAC	500mA				
929	I6TB2-6	N.C.	MODULE SUMMARY ALARM	125VAC	500mA				
930	I6TB2-5	COMM.	MODULE SUMMARY ALARM	125VAC	500mA				
931	I6TB2-1	N.O.	NEW ALARM	125VAC	500mA				
932	I6TB2-3	N.C.	NEW ALARM	125VAC	500mA				
933	I6TB2-2	COMM.	NEW ALARM	125VAC	500mA				

NOTES:

- EACH CABLE GROUP MUST BE RUN IN A SEPARATE STEEL RACEWAY TO PREVENT CONTROL SIGNAL INTERFERENCE.
- CABLE GROUP #14 AND STANDARD SCC CABLE GROUP #6 MAY BE RUN IN THE SAME CONDUIT.
- THE CONTACTS ARE ALSO RATED 2A MAX. AT 30 VDC MAX.
- REFER TO UPS MODULE CONTROL CONNECTION LOCATION DIAGRAM FOR LOCATION OF WIRING CONNECTIONS.
- F.B.O. - FURNISHED BY OTHERS.
- ALL EXTERNAL WIRE FURNISHED BY OTHERS.
- N.O. = NORMALLY OPEN, N.C. = NORMALLY CLOSED, COMM. = COMMON.
- ALL WIRING MUST BE IN ACCORDANCE WITH NATIONAL AND LOCAL ELECTRICAL CODES.
- REPEAT FOR ALL 6 PRESENT MODULES (AND 2 FUTURE)

96-797619-128
Rev. 04

Figure 47 Control wire list, external interconnections, Multi-Module System, battery temperature sensor option, Cable Group #15

WIRE NO.	TERMINAL DESIGNATION		SIGNAL NAME	MAXIMUM VOLTAGE	MAXIMUM CURRENT	COLOR	WIRE SIZE & TYPE	MAX. LENGTH	REMARKS
	FROM	TO							
CABLE GROUP #15 FROM TB60 IN UPS MODULE TO OPTIONAL BATTERY TEMP SENSOR									
940	TB60-1	TB1-1	BATTERY TEMP. SENSOR	24VDC	100mA	WHITE	2/C #18 (1.0 mm ²) TWISTED PAIR SHIELDED	100 FT. (30 METERS)	BELDEN 8760 OR EQUAL
941	TB60-2	TB1-2	BATTERY TEMP. SENSOR	24VDC	100mA	BLACK			
942	TB60-3	---	SHIELD	24VDC	100mA	SHIELD			

NOTES:

1. EACH CABLE GROUP MUST BE RUN IN A SEPARATE STEEL RACEWAY TO PREVENT CONTROL SIGNAL INTERFERENCE.
2. REFER TO UPS MODULE CONTROL CONNECTION LOCATION DIAGRAM FOR LOCATION OF WIRING CONNECTIONS.
3. ALL EXTERNAL WIRE FURNISHED BY OTHERS.
4. ALL WIRING MUST BE IN ACCORDANCE WITH NATIONAL AND LOCAL ELECTRICAL CODES.

96-797619-62
Rev. 06

Figure 48 Control wire list, external interconnections, Multi-Module System, maintenance bypass interlock option, Cable Group #7

WIRE NO.	TERMINAL DESIGNATION		SIGNAL NAME	MAXIMUM VOLTAGE	MAXIMUM CURRENT	COLOR	WIRE SIZE & TYPE	MAX. LENGTH	REMARKS
	FROM	TO							
CABLE GROUP #7 FROM I10 IN SYSTEM CONTROL CABINET TO OPTIONAL MAINTENANCE BYPASS									
771	I10TB2-1	1	ON BYPASS N.O.	120VAC	5 A		1/C #14 (2.5 mm ² sq)	500 FT. (150 METERS)	
772	I10TB2-3	2	ON BYPASS COMM.	120VAC	5 A				
773	I10TB2-4	3	MBB EPO N.O.	120VAC	5 A				
774	I10TB2-6	4	MBB EPO COMM.	120VAC	5 A				
775	I10TB2-7	5	TRANSFER INHIBIT	120VAC	5 A				
777	I10TB2-8	6	TRANSFER INHIBIT	120VAC	5 A				

NOTES:

1. EACH CABLE GROUP MUST BE RUN IN A SEPARATE STEEL RACEWAY TO PREVENT CONTROL SIGNAL INTERFERENCE.
2. REFER TO SCC CONTROL CONNECTION LOCATION DIAGRAM FOR LOCATION OF WIRING CONNECTIONS.
3. ALL EXTERNAL WIRE FURNISHED BY OTHERS.
4. N.O. = NORMALLY OPEN, COMM. = COMMON.
5. ALL WIRING MUST BE IN ACCORDANCE WITH NATIONAL AND LOCAL ELECTRICAL CODES.

96-797619-90
Rev. 04

Figure 49 Control wire list, external interconnections, Multi-Module System, SNMP interface option, Cable Group #26

WIRE NO.	TERMINAL DESIGNATION		SIGNAL NAME	MAXIMUM VOLTAGE	MAXIMUM CURRENT	COLOR	WIRE SIZE & TYPE	MAX. LENGTH	REMARKS
	FROM	TO							
CABLE GROUP #26 FROM J1 & J4 IN SYSTEM CONTROL CABINET TO CUSTOMER CONNECTION (F.B.O)									
---	J1	ETHERNET NETWORK CONNECTOR	ETHERNET NETWORK	N/A	N/A		TELEPHONE CABLE	LENGTH LIMITED BY INTERNET STANDARDS	
---	J4	SETUP PORT ON PC	SETUP	---	---				

NOTES:

1. EACH CABLE GROUP MUST BE RUN IN A SEPARATE STEEL RACEWAY TO PREVENT CONTROL SIGNAL INTERFERENCE.
2. REFER TO SCC CONTROL CONNECTION LOCATION OF DIAGRAM FOR LOCATION OF WIRING CONNECTIONS.
3. F.B.O. - FURNISHED BY OTHERS.
4. ALL EXTERNAL WIRE FURNISHED BY OTHERS.
5. ALL WIRING MUST BE IN ACCORDANCE WITH NATIONAL AND LOCAL ELECTRICAL CODES.
4. SYSTEM "A" SHOWN REPEAT FOR SYSTEM "B"

96-797619-91
Rev. 02

Figure 50 Control wire list, external interconnections, Multi-Module System, Module 1/SCC, Cable Groups #20 & #21

WIRE NO.	TERMINAL DESIGNATION		SIGNAL NAME	MAXIMUM VOLTAGE	MAXIMUM CURRENT	COLOR	WIRE SIZE & TYPE	MAX. LENGTH	REMARKS
	FROM	TO							
CABLE GROUP #20 FROM IFM I8 & I9 IN UPS MODULE 1 TO IFM I11 IN SYSTEM CONTROL CABINET									
101	I8TB1-1	IM1TB1-1	OSC. SYNC.	24VDC	100mA	WHITE	2/C #18 (1.0 mmsq) TWISTED PAIR SHIELDED	100 FT. (30 METERS)	18/C TW PR SHD #18 (1.0 mmsq) BELDEN 9390 OR 7-2/C SHD #18 (1.0 mmsq) BELDEN 8760 OR EQUAL
102	I8TB1-2	IM1TB1-2	OSC. SYNC.	24VDC	100mA	BLACK			
---	I8TB1-3	IM1TB1-3	OSC. SYNC.	24VDC	100mA	SHIELD	2/C #18 (1.0 mmsq) TWISTED PAIR SHIELDED	100 FT. (30 METERS)	18/C TW PR SHD #18 (1.0 mmsq) BELDEN 9390 OR 7-2/C SHD #18 (1.0 mmsq) BELDEN 8760 OR EQUAL
---	I8TB1-4	IM1TB1-4	PHASE SYNC.	24VDC	100mA	SHIELD			
103	I8TB1-5	IM1TB1-5	PHASE SYNC.	24VDC	100mA	BLACK	2/C #18 (1.0 mmsq) TWISTED PAIR SHIELDED	100 FT. (30 METERS)	18/C TW PR SHD #18 (1.0 mmsq) BELDEN 9390 OR 7-2/C SHD #18 (1.0 mmsq) BELDEN 8760 OR EQUAL
104	I8TB1-6	IM1TB1-6	PHASE SYNC.	24VDC	100mA	WHITE			
105	I8TB1-7	IM1TB1-7	FREQUENCY CONTROL	24VDC	100mA	BLACK/WHITE	2/C #18 (1.0 mmsq) TWISTED PAIR SHIELDED	100 FT. (30 METERS)	18/C TW PR SHD #18 (1.0 mmsq) BELDEN 9390 OR 7-2/C SHD #18 (1.0 mmsq) BELDEN 8760 OR EQUAL
---	I8TB1-8	IM1TB1-8	FREQUENCY CONTROL	24VDC	100mA	SHIELD			
106	I8TB1-9	IM1TB1-9	GROUND	24VDC	100mA		1/C #14 (2.5 mmsq)	100 FT. (30 METERS)	18/C TW PR SHD #18 (1.0 mmsq) BELDEN 9390 OR 7-2/C SHD #18 (1.0 mmsq) BELDEN 8760 OR EQUAL
107	I8TB1-10	IM1TB1-10	EMO SUPPLY	24VDC	100mA				
108	I8TB1-11	IM1TB1-11	MAJORITY FAIL	24VDC	100mA	WHITE	2/C #18 (1.0 mmsq) TWISTED PAIR SHIELDED	100 FT. (30 METERS)	18/C TW PR SHD #18 (1.0 mmsq) BELDEN 9390 OR 7-2/C SHD #18 (1.0 mmsq) BELDEN 8760 OR EQUAL
109	I8TB1-12	IM1TB1-12	MAJORITY FAIL	24VDC	100mA	BLACK			
---	I8TB1-13	IM1TB1-13	MAJORITY FAIL	24VDC	100mA	SHIELD	2/C #18 (1.0 mmsq) TWISTED PAIR SHIELDED	100 FT. (30 METERS)	18/C TW PR SHD #18 (1.0 mmsq) BELDEN 9390 OR 7-2/C SHD #18 (1.0 mmsq) BELDEN 8760 OR EQUAL
---	I9TB1-3	IM1TB1-19	LINE DROP COMP.	24VDC	100mA	SHIELD			
110	I9TB1-4	IM1TB1-20	LINE DROP COMP.	24VDC	100mA	BLACK/WHITE	2/C #18 (1.0 mmsq) TWISTED PAIR SHIELDED	100 FT. (30 METERS)	18/C TW PR SHD #18 (1.0 mmsq) BELDEN 9390 OR 7-2/C SHD #18 (1.0 mmsq) BELDEN 8760 OR EQUAL
---	I9TB1-5	IM1TB1-21	VOLT CONTROL	24VDC	100mA	SHIELD			
111	I9TB1-6	IM1TB1-22	VOLT CONTROL	24VDC	100mA	BLACK/WHITE	2/C #18 (1.0 mmsq) TWISTED PAIR SHIELDED	100 FT. (30 METERS)	18/C TW PR SHD #18 (1.0 mmsq) BELDEN 9390 OR 7-2/C SHD #18 (1.0 mmsq) BELDEN 8760 OR EQUAL
---	I9TB1-8	IM1TB1-24	CURRENT SHARE	24VDC	100mA	SHIELD			
112	I9TB1-9	IM1TB1-25	CURRENT SHARE	24VDC	100mA	WHITE	2/C #18 (1.0 mmsq) TWISTED PAIR SHIELDED	100 FT. (30 METERS)	18/C TW PR SHD #18 (1.0 mmsq) BELDEN 9390 OR 7-2/C SHD #18 (1.0 mmsq) BELDEN 8760 OR EQUAL
113	I9TB1-10	IM1TB1-26	CURRENT SHARE	24VDC	100mA	BLACK			
CABLE GROUP #21 FROM IFM I7 & TB10 IN UPS MODULE 1 TO IFM I11 & I2 IN SYSTEM CONTROL CABINET									
114	I7TB51-1	I11TB1-7	COMMUNICATIONS	24VDC	100mA	-	3/C #22 SHIELDED	100 FT. (30 METERS)	COM PWA I7 02-810015-10 BELDEN 8771 OR EQUAL
115	I7TB51-2	I11TB1-6	COMMUNICATIONS	24VDC	100mA	-			
116	I7TB51-3	I11TB1-8	COMMUNICATIONS	24VDC	100mA	-	1/C #14 (2.5 mmsq)	100 FT. (30 METERS)	OPTION
---	-	I11TB1-9	COMMUNICATIONS	24VDC	100mA	SHD			
117	TB10-2	I2TB2-1	2 STEP BATTERY LIMIT	24VDC	100mA		1/C #14 (2.5 mmsq)	100 FT. (30 METERS)	OPTION
118	TB10-1	I2TB2-2	2 STEP BATTERY LIMIT	24VDC	100mA				
119	TB10-4	I19TB2-1	2 STEP INPUT LIMIT	24VDC	100mA		1/C #14 (2.5 mmsq)	100 FT. (30 METERS)	OPTION
120	TB10-3	I19TB2-2	2 STEP INPUT LIMIT	24VDC	100mA				

- NOTES:
1. EACH CABLE GROUP MUST BE RUN IN A SEPARATE GROUNDED RIGID METAL CONDUIT TO PREVENT CONTROL SIGNAL INTERFERENCE.
 2. REFER TO UPS MODULE / SCC CONTROL CONNECTION LOCATION DIAGRAM FOR CONNECTIONS.
 3. ALL EXTERNAL WIRE FURNISHED BY OTHERS.
 4. ALL WIRING MUST BE IN ACCORDANCE WITH NATIONAL AND LOCAL ELECTRICAL CODES.

FOR UNITS MANUFACTURED BEFORE 12/31/02, SEE DRAWING 96-797619-52

96-797619-52A
Rev. 04

Figure 51 Control wire list, external interconnections, Multi-Module System, Module 2/SCC, Cable Groups #20 & #21

WIRE NO.	TERMINAL DESIGNATION		SIGNAL NAME	MAXIMUM VOLTAGE	MAXIMUM CURRENT	COLOR	WIRE SIZE & TYPE	MAX. LENGTH	REMARKS
	FROM	TO							
CABLE GROUP #20 FROM IFM 18 & 19 IN UPS MODULE 2 TO IFM IM2 IN SYSTEM CONTROL CABINET									
201	I8TB1-1	IM2TB1-1	OSC. SYNC.	24VDC	100mA	WHITE	2/C #18 (1.0 mm ²) TWISTED PAIR SHIELDED	100 FT. (30 METERS)	18/C TW PR SHD #18 (1.0 mm ²) BELDEN 9390 OR 7-2/C SHD #18 (1.0 mm ²) BELDEN 8760 OR EQUAL
202	I8TB1-2	IM2TB1-2	OSC. SYNC.	24VDC	100mA	BLACK			
--	I8TB1-3	IM2TB1-3	OSC. SYNC.	24VDC	100mA	SHIELD			
--	I8TB1-4	IM2TB1-4	PHASE SYNC.	24VDC	100mA	SHIELD	2/C #18 (1.0 mm ²) TWISTED PAIR SHIELDED		
203	I8TB1-5	IM2TB1-5	PHASE SYNC.	24VDC	100mA	BLACK			
204	I8TB1-6	IM2TB1-6	PHASE SYNC.	24VDC	100mA	WHITE			
205	I8TB1-7	IM2TB1-7	FREQUENCY CONTROL	24VDC	100mA	BLACK/WHITE	2/C #18 (1.0 mm ²) TWISTED PAIR SHIELDED	100 FT. (30 METERS)	
--	I8TB1-8	IM2TB1-8	FREQUENCY CONTROL	24VDC	100mA	SHIELD			
206	I8TB1-9	IM2TB1-9	GROUND	24VDC	100mA		1/C #14 (2.5 mm ²)		
207	I8TB1-10	IM2TB1-10	EMO SUPPLY	24VDC	100mA				
208	I8TB1-11	IM2TB1-11	MAJORITY FAIL	24VDC	100mA	WHITE		100 FT. (30 METERS)	18/C TW PR SHD #18 (1.0 mm ²) BELDEN 9390 OR 7-2/C SHD #18 (1.0 mm ²) BELDEN 8760 OR EQUAL
209	I8TB1-12	IM2TB1-12	MAJORITY FAIL	24VDC	100mA	BLACK	2/C #18 (1.0 mm ²) TWISTED PAIR SHIELDED		
--	I8TB1-13	IM2TB1-13	MAJORITY FAIL	24VDC	100mA	SHIELD			
--	I9TB1-3	IM2TB1-19	LINE DROP COMP.	24VDC	100mA	SHIELD	2/C #18 (1.0 mm ²) TWISTED PAIR SHIELDED		
210	I9TB1-4	IM2TB1-20	LINE DROP COMP.	24VDC	100mA	BLACK/WHITE			
--	I9TB1-5	IM2TB1-21	VOLT CONTROL	24VDC	100mA	SHIELD	2/C #18 (1.0 mm ²) TWISTED PAIR SHIELDED		
211	I9TB1-6	IM2TB1-22	VOLT CONTROL	24VDC	100mA	BLACK/WHITE			
--	I9TB1-8	IM2TB1-24	CURRENT SHARE	24VDC	100mA	SHIELD			
212	I9TB1-9	IM2TB1-25	CURRENT SHARE	24VDC	100mA	WHITE	2/C #18 (1.0 mm ²) TWISTED PAIR SHIELDED		
213	I9TB1-10	IM2TB1-26	CURRENT SHARE	24VDC	100mA	BLACK			
CABLE GROUP #21 FROM IFM 17 & TB10 IN UPS MODULE 2 TO IFM I11 & I2 IN SYSTEM CONTROL CABINET									
214	I7TB51-1	I11TB1-11	COMMUNICATIONS	24VDC	100mA	-		100 FT. (30 METERS)	3/C #22 SHIELDED BELDEN 8771 OR EQUAL COM PVA 17 02-810015-10
215	I7TB51-2	I11TB1-10	COMMUNICATIONS	24VDC	100mA	-	3/C #22 SHIELDED		
216	I7TB51-3	I11TB1-12	COMMUNICATIONS	24VDC	100mA	-			
--	-	I11TB1-13	COMMUNICATIONS	24VDC	100mA	SHD			
217	TB10-2	I2TB2-3	2 STEP BATTERY LIMIT	24VDC	100mA		1/C #14 (2.5 mm ²)	100 FT. (30 METERS)	
218	TB10-1	I2TB2-4	2 STEP BATTERY LIMIT	24VDC	100mA				
219	TB10-4	I19TB2-3	2 STEP INPUT LIMIT	24VDC	100mA		1/C #14 (2.5 mm ²)	100 FT. (30 METERS)	OPTION
220	TB10-3	I19TB2-4	2 STEP INPUT LIMIT	24VDC	100mA				

- NOTES:
1. EACH CABLE GROUP MUST BE RUN IN A SEPARATE GROUNDED RIGID METAL CONDUIT TO PREVENT CONTROL SIGNAL INTERFERENCE.
 2. REFER TO UPS MODULE / SCC CONTROL CONNECTION LOCATION DIAGRAM FOR CONNECTIONS.
 3. ALL EXTERNAL WIRE FURNISHED BY OTHERS.
 4. ALL WIRING MUST BE IN ACCORDANCE WITH NATIONAL AND LOCAL ELECTRICAL CODES.
 5. SYSTEM "A" SHOWN REPEAT FOR SYSTEM "B"

FOR UNITS MANUFACTURED BEFORE 12/31/02, SEE DRAWING 96-797619-53

96-797619-53A
Rev. 04

Figure 52 Control wire list, external interconnections, Multi-Module System, Module 3/SCC, Cable Groups #20 & #21

WIRE NO.	TERMINAL DESIGNATION		SIGNAL NAME	MAXIMUM VOLTAGE	MAXIMUM CURRENT	COLOR	WIRE SIZE & TYPE	MAX. LENGTH	REMARKS
	FROM	TO							
CABLE GROUP #20 FROM IFM 18 & 19 IN UPS MODULE 3 TO IFM IM3 IN SYSTEM CONTROL CABINET									
301	I8TB1-1	IM3TB1-1	OSC. SYNC.	24VDC	100mA	WHITE	2/C #18 (1.0 mm ²) TWISTED PAIR SHIELDED	100 FT. (30 METERS)	18/C TW PR SHD #18 (1.0 mm ²) BELDEN 9390 OR 7-2/C SHD #18 (1.0 mm ²) BELDEN 8760 OR EQUAL
302	I8TB1-2	IM3TB1-2	OSC. SYNC.	24VDC	100mA	BLACK			
---	I8TB1-3	IM3TB1-3	OSC. SYNC.	24VDC	100mA	SHIELD			
---	I8TB1-4	IM3TB1-4	PHASE SYNC.	24VDC	100mA	SHIELD	2/C #18 (1.0 mm ²) TWISTED PAIR SHIELDED		
303	I8TB1-5	IM3TB1-5	PHASE SYNC.	24VDC	100mA	BLACK	2/C #18 (1.0 mm ²) TWISTED PAIR SHIELDED		
304	I8TB1-6	IM3TB1-6	PHASE SYNC.	24VDC	100mA	WHITE	2/C #18 (1.0 mm ²) TWISTED PAIR SHIELDED		
305	I8TB1-7	IM3TB1-7	FREQUENCY CONTROL	24VDC	100mA	BLACK/WHITE	2/C #18 (1.0 mm ²) TWISTED PAIR SHIELDED		
---	I8TB1-8	IM3TB1-8	FREQUENCY CONTROL	24VDC	100mA	SHIELD			
306	I8TB1-9	IM3TB1-9	GROUND	24VDC	100mA		1/C #14 (2.5 mm ²)	100 FT. (30 METERS)	
307	I8TB1-10	IM3TB1-10	EMO SUPPLY	24VDC	100mA				
308	I8TB1-11	IM3TB1-11	MAJORITY FAIL	24VDC	100mA	WHITE	2/C #18 (1.0 mm ²) TWISTED PAIR SHIELDED	100 FT. (30 METERS)	18/C TW PR SHD #18 (1.0 mm ²) BELDEN 9390 OR 7-2/C SHD #18 (1.0 mm ²) BELDEN 8760 OR EQUAL
309	I8TB1-12	IM3TB1-12	MAJORITY FAIL	24VDC	100mA	BLACK			
---	I8TB1-13	IM3TB1-13	MAJORITY FAIL	24VDC	100mA	SHIELD			
---	I9TB1-3	IM3TB1-19	LINE DROP COMP.	24VDC	100mA	SHIELD	2/C #18 (1.0 mm ²) TWISTED PAIR SHIELDED		
310	I9TB1-4	IM3TB1-20	LINE DROP COMP.	24VDC	100mA	BLACK/WHITE	2/C #18 (1.0 mm ²) TWISTED PAIR SHIELDED		
---	I9TB1-5	IM3TB1-21	VOLT CONTROL	24VDC	100mA	SHIELD	2/C #18 (1.0 mm ²) TWISTED PAIR SHIELDED		
311	I9TB1-6	IM3TB1-22	VOLT CONTROL	24VDC	100mA	BLACK/WHITE	2/C #18 (1.0 mm ²) TWISTED PAIR SHIELDED		
---	I9TB1-8	IM3TB1-24	CURRENT SHARE	24VDC	100mA	SHIELD	2/C #18 (1.0 mm ²) TWISTED PAIR SHIELDED		
312	I9TB1-9	IM3TB1-25	CURRENT SHARE	24VDC	100mA	WHITE	2/C #18 (1.0 mm ²) TWISTED PAIR SHIELDED		
313	I9TB1-10	IM3TB1-26	CURRENT SHARE	24VDC	100mA	BLACK	2/C #18 (1.0 mm ²) TWISTED PAIR SHIELDED		
CABLE GROUP #21 FROM IFM I7 & TB10 IN UPS MODULE 3 TO IFM I11 & I2 IN SYSTEM CONTROL CABINET									
314	I7TB51-1	I11TB1-15	COMMUNICATIONS	24VDC	100mA	-	3/C #22 SHIELDED BELDEN 8771 OR EQUAL	100 FT. (30 METERS)	
315	I7TB51-2	I11TB1-14	COMMUNICATIONS	24VDC	100mA	-			
316	I7TB51-3	I11TB1-16	COMMUNICATIONS	24VDC	100mA	-			
---	-	I11TB1-17	COMMUNICATIONS	24VDC	100mA	SHD			
317	TB10-2	I2TB2-5	2 STEP BATTERY LIMIT	24VDC	100mA		1/C #14 (2.5 mm ²)	100 FT. (30 METERS)	
318	TB10-1	I2TB2-6	2 STEP BATTERY LIMIT	24VDC	100mA				
319	TB10-4	I19TB2-5	2 STEP INPUT LIMIT	24VDC	100mA		1/C #14 (2.5 mm ²)	100 FT. (30 METERS)	OPTION
320	TB10-3	I19TB2-6	2 STEP INPUT LIMIT	24VDC	100mA				

- NOTES:
1. EACH CABLE GROUP MUST BE RUN IN A SEPARATE GROUNDED RIGID METAL CONDUIT TO PREVENT CONTROL SIGNAL INTERFERENCE.
 2. REFER TO UPS MODULE / SCC CONTROL CONNECTION LOCATION DIAGRAM FOR LOCATION OF WIRING CONNECTIONS.
 3. ALL EXTERNAL WIRE FURNISHED BY OTHERS.
 4. ALL WIRING MUST BE IN ACCORDANCE WITH NATIONAL AND LOCAL ELECTRICAL CODES.
 5. SYSTEM "A" SHOWN REPEAT FOR SYSTEM "B"

FOR UNITS MANUFACTURED BEFORE 12/31/02, SEE DRAWING 96-797619-54

96-797619-54A
Rev. 04

Figure 53 Control wire list, external interconnections, Multi-Module System, Module 4/SCC, Cable Groups #20 & #21

WIRE NO.	TERMINAL DESIGNATION		SIGNAL NAME	MAXIMUM VOLTAGE	MAXIMUM CURRENT	COLOR	WIRE SIZE & TYPE	MAX. LENGTH	REMARKS
	FROM	TO							
CABLE GROUP #20 FROM IFM 18 & 19 IN UPS MODULE 4 TO IFM IM4 IN SYSTEM CONTROL CABINET									
401	I8TB1-1	IM4TB1-1	OSC. SYNC.	24VDC	100mA	WHITE	2/C #18 (1.0 mmsq) TWISTED PAIR SHIELDED	100 FT. (30 METERS)	18/C TW PR SHD #18 (1.0 mmsq) BELDEN 8390 OR 7-2/C SHD #18 (1.0 mmsq) BELDEN 8760 OR EQUAL
402	I8TB1-2	IM4TB1-2	OSC. SYNC.	24VDC	100mA	BLACK			
---	I8TB1-3	IM4TB1-3	OSC. SYNC.	24VDC	100mA	SHIELD			
---	I8TB1-4	IM4TB1-4	PHASE SYNC.	24VDC	100mA	SHIELD	2/C #18 (1.0 mmsq) TWISTED PAIR SHIELDED		
403	I8TB1-5	IM4TB1-5	PHASE SYNC.	24VDC	100mA	BLACK			
404	I8TB1-6	IM4TB1-6	PHASE SYNC.	24VDC	100mA	WHITE			
405	I8TB1-7	IM4TB1-7	FREQUENCY CONTROL	24VDC	100mA	BLACK/WHITE	2/C #18 (1.0 mmsq) TWISTED PAIR SHIELDED	100 FT. (30 METERS)	
---	I8TB1-8	IM4TB1-8	FREQUENCY CONTROL	24VDC	100mA	SHIELD			
406	I8TB1-9	IM4TB1-9	GROUND	24VDC	100mA		1/C #14 (2.5 mmsq)		
407	I8TB1-10	IM4TB1-10	EMO SUPPLY	24VDC	100mA				
408	I8TB1-11	IM4TB1-11	MAJORITY FAIL	24VDC	100mA	WHITE			
409	I8TB1-12	IM4TB1-12	MAJORITY FAIL	24VDC	100mA	BLACK	2/C #18 (1.0 mmsq) TWISTED PAIR SHIELDED	100 FT. (30 METERS)	18/C TW PR SHD #18 (1.0 mmsq) BELDEN 8390 OR 7-2/C SHD #18 (1.0 mmsq) BELDEN 8760 OR EQUAL
---	I8TB1-13	IM4TB1-13	MAJORITY FAIL	24VDC	100mA	SHIELD			
---	I8TB1-3	IM4TB1-19	LINE DROP COMP.	24VDC	100mA	SHIELD	2/C #18 (1.0 mmsq) TWISTED PAIR SHIELDED		
410	I8TB1-4	IM4TB1-20	LINE DROP COMP.	24VDC	100mA	BLACK/WHITE			
---	I8TB1-5	IM4TB1-21	VOLT CONTROL	24VDC	100mA	SHIELD	2/C #18 (1.0 mmsq) TWISTED PAIR SHIELDED		
411	I8TB1-6	IM4TB1-22	VOLT CONTROL	24VDC	100mA	BLACK/WHITE			
---	I8TB1-8	IM4TB1-24	CURRENT SHARE	24VDC	100mA	SHIELD	2/C #18 (1.0 mmsq) TWISTED PAIR SHIELDED		
412	I8TB1-9	IM4TB1-25	CURRENT SHARE	24VDC	100mA	WHITE			
413	I8TB1-10	IM4TB1-26	CURRENT SHARE	24VDC	100mA	BLACK			
CABLE GROUP #21 FROM IFM 17 & TB10 IN UPS MODULE 4 TO IFM 111 & 12 IN SYSTEM CONTROL CABINET									
414	I7TB51-1	I11TB1-19	COMMUNICATIONS	24VDC	100mA	-		100 FT. (30 METERS)	3/C #22 SHIELDED BELDEN 8771 OR EQUAL COM PWA 17 02-810015-10
415	I7TB51-2	I11TB1-18	COMMUNICATIONS	24VDC	100mA	-	3/C #22 SHIELDED		
416	I7TB51-3	I11TB1-20	COMMUNICATIONS	24VDC	100mA	-			
---	-	I11TB1-21	COMMUNICATIONS	24VDC	100mA	SHD			
417	TB10-2	I2TB2-7	2 STEP BATTERY LIMIT	24VDC	100mA		1/C #14 (2.5 mmsq)	100 FT. (30 METERS)	
418	TB10-1	I2TB2-8	2 STEP BATTERY LIMIT	24VDC	100mA				
419	TB10-4	I19TB2-7	2 STEP INPUT LIMIT	24VDC	100mA				
420	TB10-3	I19TB2-8	2 STEP INPUT LIMIT	24VDC	100mA		1/C #14 (2.5 mmsq)	100 FT. (30 METERS)	OPTION

FOR UNITS MANUFACTURED BEFORE 12/31/02, SEE DRAWING 96-797619-55

- NOTES:
1. EACH CABLE GROUP MUST BE RUN IN A SEPARATE GROUNDED RIGID METAL CONDUIT TO PREVENT CONTROL SIGNAL INTERFERENCE.
 2. REFER TO UPS MODULE/SCC CONTROL CONNECTION LOCATION DIAGRAM FOR LOCATION OF WIRING CONNECTIONS.
 3. ALL EXTERNAL WIRE FURNISHED BY OTHERS.
 4. ALL WIRING MUST BE IN ACCORDANCE WITH NATIONAL AND LOCAL ELECTRICAL CODES.
 5. SYSTEM "A" SHOWN REPEAT FOR SYSTEM "B"

Figure 54 Control wire list, external interconnections, Multi-Module System, Module 5/SCC, Cable Groups #20 & #21

WIRE NO.	TERMINAL DESIGNATION		SIGNAL NAME	MAXIMUM VOLTAGE	MAXIMUM CURRENT	COLOR	WIRE SIZE & TYPE	MAX. LENGTH	REMARKS
	FROM	TO							
CABLE GROUP #20 FROM IFM 18 & 19 IN UPS MODULE 5 TO IFM 1M5 IN SYSTEM CONTROL CABINET									
501	I8TB1-1	IM5TB1-1	OSC. SYNC.	24VDC	100mA	WHITE	2/C #18 (1.0 mmsq) TWISTED PAIR SHIELDED	100 FT. (30 METERS)	18/C TW PR SHD #18 (1.0 mmsq) BELDEN 9390 OR 7-2/C SHD #18 (1.0 mmsq) BELDEN 8760 OR EQUAL
502	I8TB1-2	IM5TB1-2	OSC. SYNC.	24VDC	100mA	BLACK			
---	I8TB1-3	IM5TB1-3	OSC. SYNC.	24VDC	100mA	SHIELD			
---	I8TB1-4	IM5TB1-4	PHASE SYNC.	24VDC	100mA	SHIELD			
503	I8TB1-5	IM5TB1-5	PHASE SYNC.	24VDC	100mA	BLACK			
504	I8TB1-6	IM5TB1-6	PHASE SYNC.	24VDC	100mA	WHITE			
505	I8TB1-7	IM5TB1-7	FREQUENCY CONTROL	24VDC	100mA	BLACK/WHITE	2/C #18 (1.0 mmsq) TWISTED PAIR SHIELDED	100 FT. (30 METERS)	
---	I8TB1-8	IM5TB1-8	FREQUENCY CONTROL	24VDC	100mA	SHIELD			
506	I8TB1-9	IM5TB1-9	GROUND	24VDC	100mA		1/C #14 (2.5 mmsq)		
507	I8TB1-10	IM5TB1-10	EMO SUPPLY	24VDC	100mA				
508	I8TB1-11	IM5TB1-11	MAJORITY FAIL	24VDC	100mA	WHITE		100 FT. (30 METERS)	18/C TW PR SHD #18 (1.0 mmsq) BELDEN 9390 OR 7-2/C SHD #18 (1.0 mmsq) BELDEN 8760 OR EQUAL
509	I8TB1-12	IM5TB1-12	MAJORITY FAIL	24VDC	100mA	BLACK	2/C #18 (1.0 mmsq) TWISTED PAIR SHIELDED		
---	I8TB1-13	IM5TB1-13	MAJORITY FAIL	24VDC	100mA	SHIELD			
---	I9TB1-3	IM5TB1-19	LINE DROP COMP.	24VDC	100mA	SHIELD	2/C #18 (1.0 mmsq) TWISTED PAIR SHIELDED		
510	I9TB1-4	IM5TB1-20	LINE DROP COMP.	24VDC	100mA	BLACK/WHITE	2/C #18 (1.0 mmsq) TWISTED PAIR SHIELDED		
---	I9TB1-5	IM5TB1-21	VOLT CONTROL	24VDC	100mA	SHIELD			
511	I9TB1-6	IM5TB1-22	VOLT CONTROL	24VDC	100mA	BLACK/WHITE	2/C #18 (1.0 mmsq) TWISTED PAIR SHIELDED	100 FT. (30 METERS)	
---	I9TB1-8	IM5TB1-24	CURRENT SHARE	24VDC	100mA	SHIELD			
512	I9TB1-9	IM5TB1-25	CURRENT SHARE	24VDC	100mA	WHITE	2/C #18 (1.0 mmsq) TWISTED PAIR SHIELDED		
---	I9TB1-10	IM5TB1-26	CURRENT SHARE	24VDC	100mA	BLACK			
513	I7TB51-1	I11TB1-23	COMMUNICATIONS	24VDC	100mA	-	3/C #22 SHIELDED		
514	I7TB51-2	I11TB1-22	COMMUNICATIONS	24VDC	100mA	-			
516	I7TB51-3	I11TB1-24	COMMUNICATIONS	24VDC	100mA	-		COM PWA 17 02-810015-10	
---	-	I11TB1-25	COMMUNICATIONS	24VDC	100mA	SHD			
517	TB10-2	I2TB2-9	2 STEP BATTERY LIMIT	24VDC	100mA		1/C #14 (2.5 mmsq)	100 FT. (30 METERS)	
518	TB10-1	I2TB2-10	2 STEP BATTERY LIMIT	24VDC	100mA				
519	TB10-4	I19TB2-9	2 STEP INPUT LIMIT	24VDC	100mA				
520	TB10-3	I19TB2-10	2 STEP INPUT LIMIT	24VDC	100mA				OPTION
CABLE GROUP #21 FROM IFM 17 & TB10 IN UPS MODULE 5 TO IFM 111 & 12 IN SYSTEM CONTROL CABINET									

- NOTES:
1. EACH CABLE GROUP MUST BE RUN IN A SEPARATE GROUNDED RIGID METAL CONDUIT TO PREVENT CONTROL SIGNAL INTERFERENCE.
 2. REFER TO UPS MODULE / SCC CONTROL CONNECTION LOCATION DIAGRAM FOR LOCATION OF WIRING CONNECTIONS.
 3. ALL EXTERNAL WIRE FURNISHED BY OTHERS.
 4. ALL WIRING MUST BE IN ACCORDANCE WITH NATIONAL AND LOCAL ELECTRICAL CODES.

FOR UNITS MANUFACTURED BEFORE 12/31/02, SEE DRAWING 96-797619-56

96-797619-56A
Rev. 04

Figure 55 Control wire list, external interconnections, Multi-Module System, Module 6/SCC, Cable Groups #20 & #21

WIRE NO.	TERMINAL DESIGNATION		SIGNAL NAME	MAXIMUM VOLTAGE	MAXIMUM CURRENT	COLOR	WIRE SIZE & TYPE	MAX. LENGTH	REMARKS
	FROM	TO							
CABLE GROUP #20 FROM IFM 18 & 19 IN UPS MODULE 6 TO IFM IM6 IN SYSTEM CONTROL CABINET									
601	I8TB1-1	IM6TB1-1	OSC. SYNC.	24VDC	100mA	WHITE	2/C #18 (1.0 mm ²) TWISTED PAIR SHIELDED	100 FT. (30 METERS)	18/C TW/PR SHD #18 (1.0 mm ²) BELDEN 9390 OR 7-2/C SHD #18 (1.0 mm ²) BELDEN 8760 OR EQUAL
602	I8TB1-2	IM6TB1-2	OSC. SYNC.	24VDC	100mA	BLACK			
---	I8TB1-3	IM6TB1-3	OSC. SYNC.	24VDC	100mA	SHIELD			
---	I8TB1-4	IM6TB1-4	PHASE SYNC.	24VDC	100mA	SHIELD	2/C #18 (1.0 mm ²) TWISTED PAIR SHIELDED		
603	I8TB1-5	IM6TB1-5	PHASE SYNC.	24VDC	100mA	BLACK			
604	I8TB1-6	IM6TB1-6	PHASE SYNC.	24VDC	100mA	WHITE			
605	I8TB1-7	IM6TB1-7	FREQUENCY CONTROL	24VDC	100mA	BLACK/WHITE	2/C #18 (1.0 mm ²) TWISTED PAIR SHIELDED	100 FT. (30 METERS)	
---	I8TB1-8	IM6TB1-8	FREQUENCY CONTROL	24VDC	100mA	SHIELD			
606	I8TB1-9	IM6TB1-9	GROUND	24VDC	100mA		1/C #14 (2.5 mm ²)		
607	I8TB1-10	IM6TB1-10	EMO SUPPLY	24VDC	100mA				
608	I8TB1-11	IM6TB1-11	MAJORITY FAIL	24VDC	100mA	WHITE	2/C #18 (1.0 mm ²) TWISTED PAIR SHIELDED	100 FT. (30 METERS)	18/C TW/PR SHD #18 (1.0 mm ²) BELDEN 9390 OR 7-2/C SHD #18 (1.0 mm ²) BELDEN 8760 OR EQUAL
609	I8TB1-12	IM6TB1-12	MAJORITY FAIL	24VDC	100mA	BLACK			
---	I8TB1-13	IM6TB1-13	MAJORITY FAIL	24VDC	100mA	SHIELD			
---	I9TB1-3	IM6TB1-19	LINE DROP COMP.	24VDC	100mA	SHIELD	2/C #18 (1.0 mm ²) TWISTED PAIR SHIELDED		
610	I9TB1-4	IM6TB1-20	LINE DROP COMP.	24VDC	100mA	BLACK/WHITE			
---	I9TB1-5	IM6TB1-21	VOLT CONTROL	24VDC	100mA	SHIELD	2/C #18 (1.0 mm ²) TWISTED PAIR SHIELDED		
611	I9TB1-6	IM6TB1-22	VOLT CONTROL	24VDC	100mA	BLACK/WHITE			
---	I9TB1-8	IM6TB1-24	CURRENT SHARE	24VDC	100mA	SHIELD			
612	I9TB1-9	IM6TB1-25	CURRENT SHARE	24VDC	100mA	WHITE	2/C #18 (1.0 mm ²) TWISTED PAIR SHIELDED		
613	I9TB1-10	IM6TB1-26	CURRENT SHARE	24VDC	100mA	BLACK			
CABLE GROUP #21 FROM IFM 17 & TB10 IN UPS MODULE 6 TO IFM I11 & I2 IN SYSTEM CONTROL CABINET									
614	I7TB51-1	I11TB1-27	COMMUNICATIONS	24VDC	100mA	-	3/C #22 SHIELDED	100 FT. (30 METERS)	3/C #22 SHIELDED BELDEN 8771 OR EQUAL COM PWA 17 02-810015-10
615	I7TB51-2	I11TB1-26	COMMUNICATIONS	24VDC	100mA	-			
616	I7TB51-3	I11TB1-28	COMMUNICATIONS	24VDC	100mA	-			
---	-	I11TB1-29	COMMUNICATIONS	24VDC	100mA	SHD			
617	TB10-2	I2TB2-11	2 STEP BATTERY LIMIT	24VDC	100mA		1/C #14 (2.5 mm ²)	100 FT. (30 METERS)	
618	TB10-1	I2TB2-12	2 STEP BATTERY LIMIT	24VDC	100mA				
619	TB10-4	I9TB2-11	2 STEP INPUT LIMIT	24VDC	100mA		1/C #14 (2.5 mm ²)	100 FT. (30 METERS)	OPTION
620	TB10-3	I9TB2-12	2 STEP INPUT LIMIT	24VDC	100mA				

- NOTES:
1. EACH CABLE GROUP MUST BE RUN IN A SEPARATE GROUNDED RIGID METAL CONDUIT TO PREVENT CONTROL SIGNAL INTERFERENCE.
 2. REFER TO UPS MODULE / SCC CONTROL CONNECTION LOCATION DIAGRAM FOR LOCATION OF WIRING CONNECTIONS.
 3. ALL EXTERNAL WIRE FURNISHED BY OTHERS.
 4. ALL WIRING MUST BE IN ACCORDANCE WITH NATIONAL AND LOCAL ELECTRICAL CODES.

FOR UNITS MANUFACTURED BEFORE 12/31/02, SEE DRAWING 96-797619-57

96-797619-57A
Rev. 04

Figure 56 Outline drawing, single-breaker module battery disconnect, 175-250A, 600VDC circuit breaker

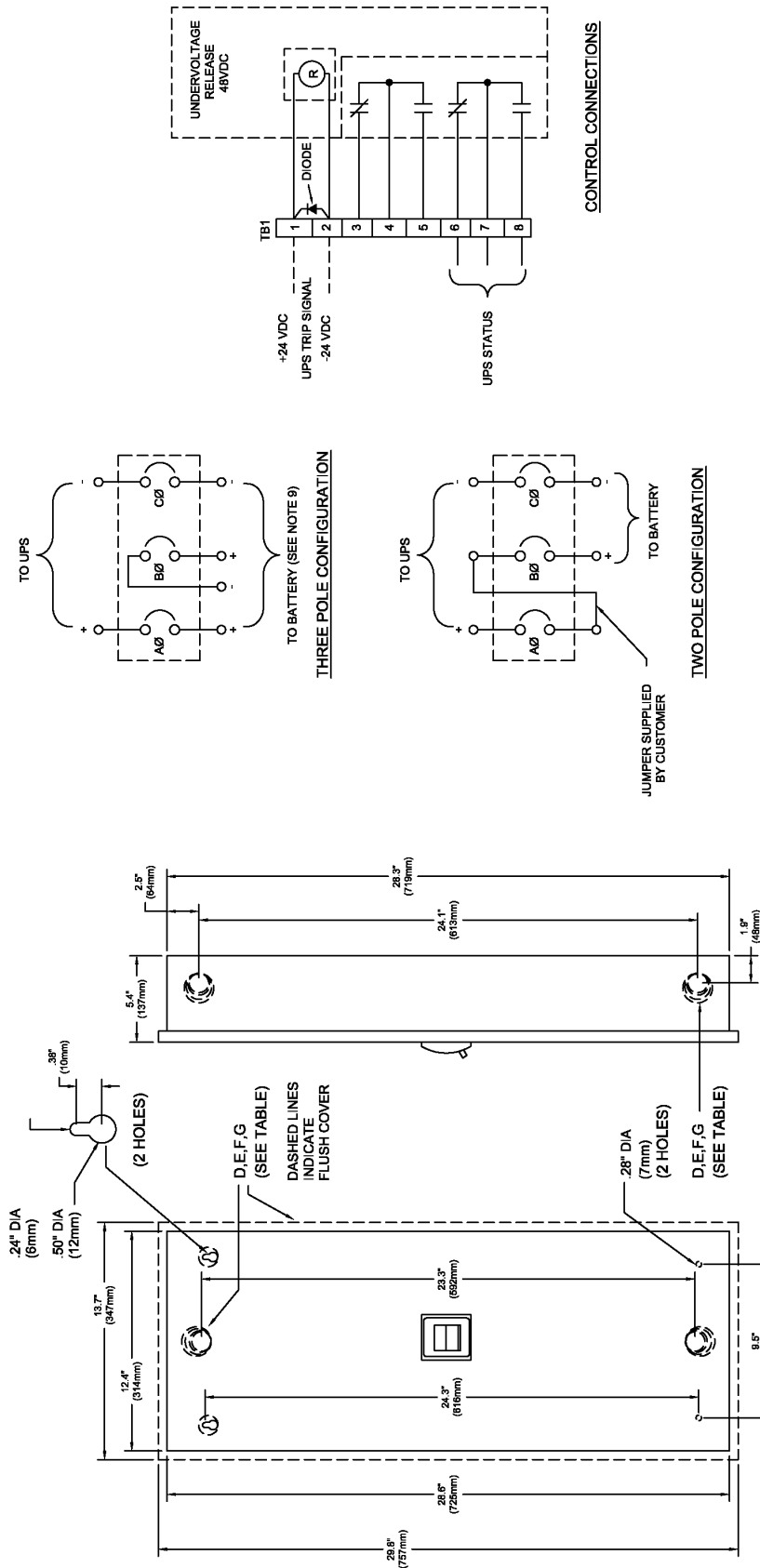

NOTES:

1. NEMA 1 ENCLOSURE PROVIDED WHICH IS SUITABLE FOR WALL MOUNTING ONLY.
2. CIRCUIT BREAKER IS SQUARE D TYPE KHL36XXXX. BREAKER INCLUDES 2(A/B) AUXILIARY CONTACTS, AND A 48VDC UNDERVOLTAGE RELEASE
3. KNOCKOUTS PROVIDED FOR FIELD WIRING CONNECTIONS.
4. FINISH IS GRAY BAKED ENAMEL.
5. FOR APPLICATIONS WHERE A TWO POLE CONFIGURATION IS REQUIRED THE CUSTOMER MUST ADD A CABLE JUMPER OF EQUAL AMPACITY TO THE BATTERY CIRCUIT CONDUCTORS AS SHOWN ON THIS DRAWING.
6. CENTER POLE USED TO BREAK MIDPOINT OF BATTERY STRING.
7. CABLE CONNECTION LUG SIZE IS (1) 6 AWG-350KCMIL CU (16-185mm²).
8. APPROXIMATE WEIGHT IS 150 LBS (68 kg).
9. CIRCUIT BREAKER INSTANTANEOUS TRIP SETTING SHOULD BE SET AT THE MINIMUM OF THE ADJUSTMENT RANGE
10. GROUND LUGS ARE PROVIDED FOR (2) #10-2/0 AWG CU (6-70mm²) CONDUCTORS.

SYMBOL	CONDUIT SIZE		DIAMETER	
	IN	mm	IN	mm
A	.50	13	.88	22
B	.75	19	1.13	29
C	1.00	25	1.38	35
D	1.25	32	1.75	45
E	1.50	38	2.00	51
F	2.00	51	2.50	64
G	2.50	54	3.00	76
H	3.00	76	3.63	92

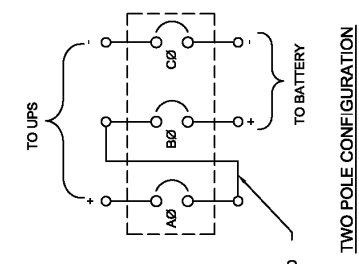
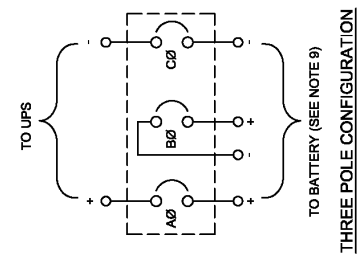
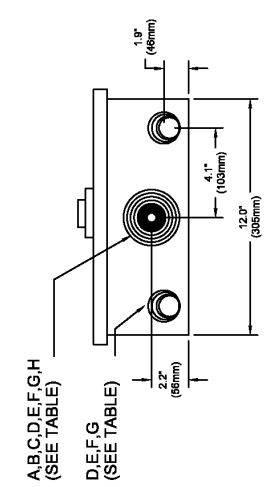

88-797606-17
Rev. 05

Figure 57 Outline drawing, dual-breaker module battery disconnect, 175-250A, 600VDC circuit breaker

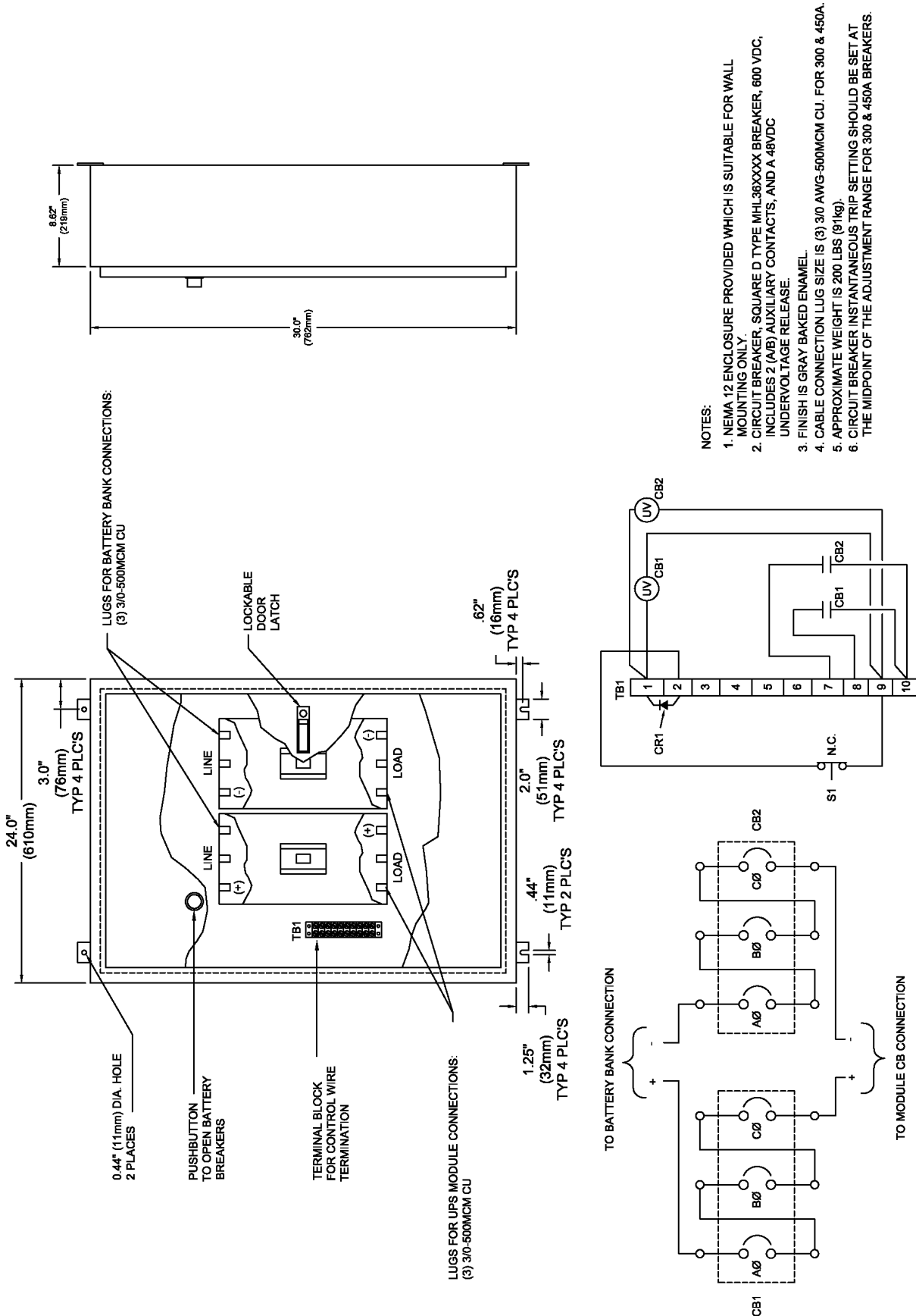

88-797616-17
 Rev. 03

Figure 58 Outline drawing, single-breaker module battery disconnect, 300, 450, 600, 800, 1000, 1200A

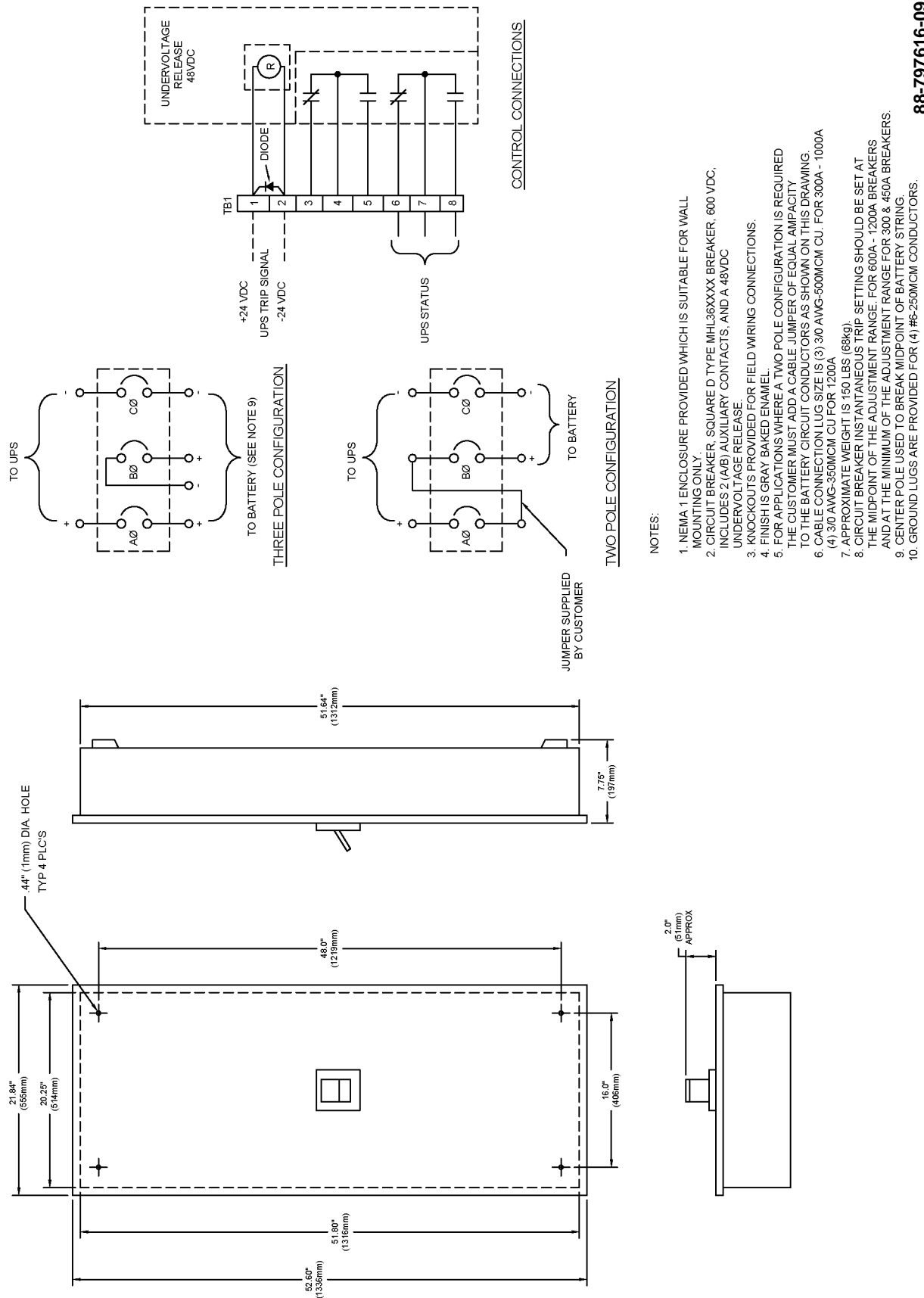

88-797616-09
Rev. 08

Figure 59 Outline drawing, dual-breaker module battery disconnect, 300 & 450A

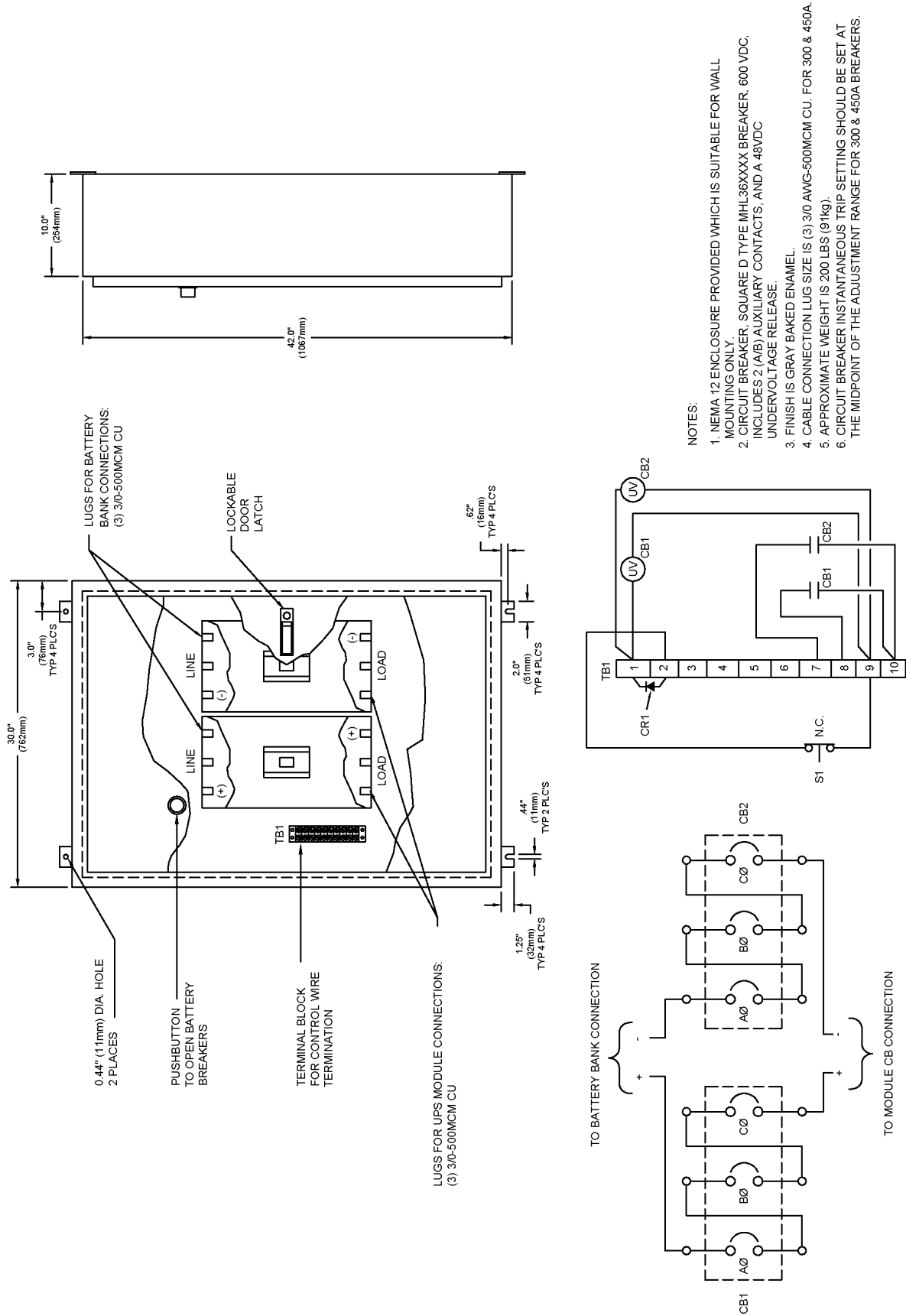

- NOTES:
1. NEMA 12 ENCLOSURE PROVIDED WHICH IS SUITABLE FOR WALL MOUNTING ONLY.
 2. CIRCUIT BREAKER, SQUARE D TYPE MHL36XXXX BREAKER, 600 VDC, INCLUDES 2 (A/B) AUXILIARY CONTACTS, AND A 48VDC UNDERVOLTAGE RELEASE.
 3. FINISH IS GRAY BAKED ENAMEL.
 4. CABLE CONNECTION LUG SIZE IS (3) 3/0 AWG-500MCM CU. FOR 300 & 450A.
 5. APPROXIMATE WEIGHT IS 200 LBS (91kg).
 6. CIRCUIT BREAKER INSTANTANEOUS TRIP SETTING SHOULD BE SET AT THE MIDPOINT OF THE ADJUSTMENT RANGE FOR 300 & 450A BREAKERS.

88-797616-08
Rev. 05

Figure 60 Outline drawing, dual-breaker module battery disconnect, 600, 800, 1000, 1200A

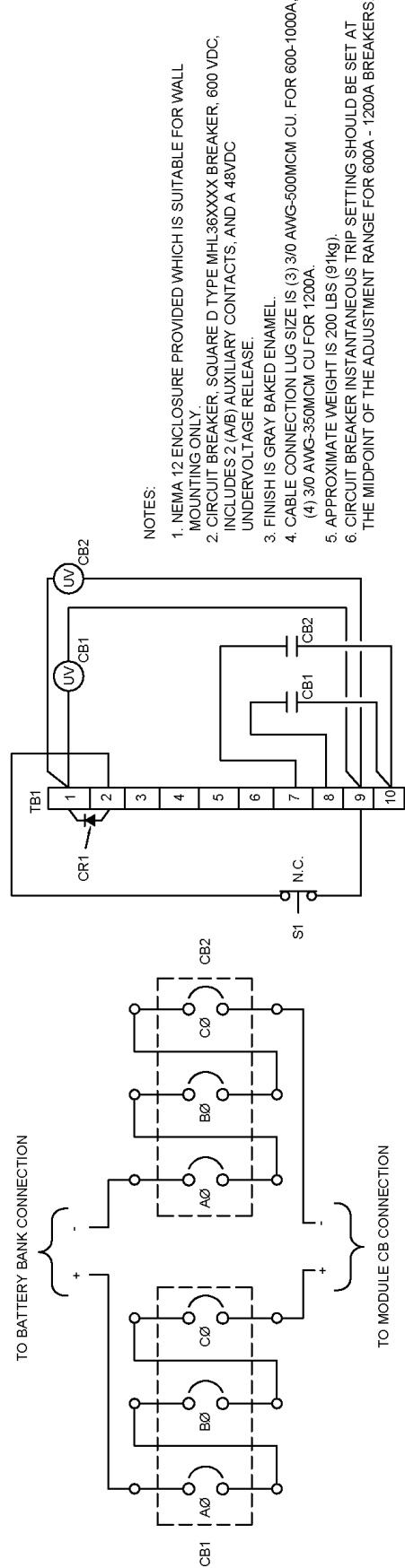
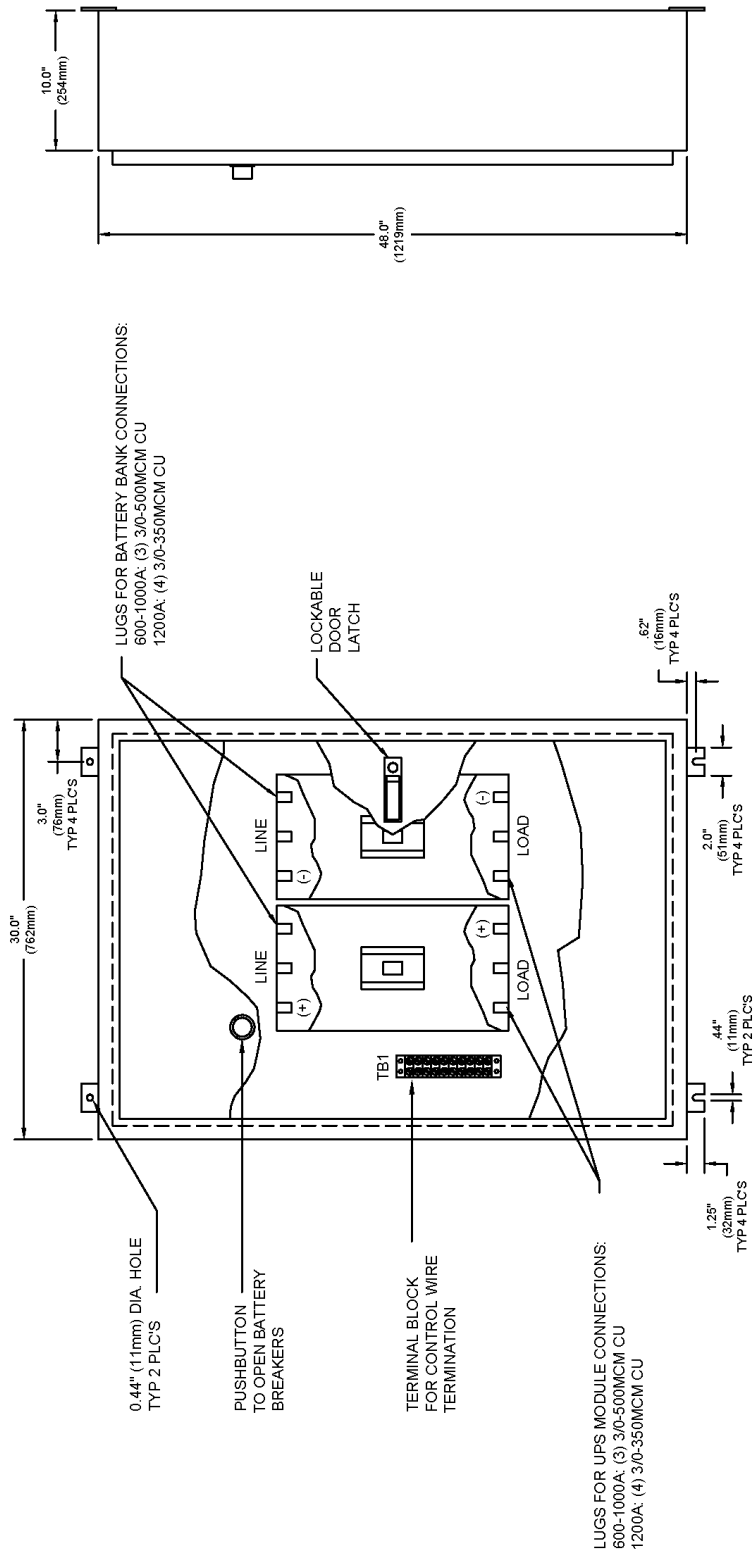

NOTES:

1. NEMA 12 ENCLOSURE PROVIDED WHICH IS SUITABLE FOR WALL MOUNTING ONLY.
2. CIRCUIT BREAKER, SQUARE D TYPE MHL36XXX BREAKER, 600 VDC, INCLUDES 2 (A/B) AUXILIARY CONTACTS, AND A 48VDC UNDERVOLTAGE RELEASE.
3. FINISH IS GRAY BAKED ENAMEL.
4. CABLE CONNECTION LUG SIZE IS (3) 3/0 AWG-500MCM CU. FOR 600-1000A, (4) 3/0 AWG-350MCM CU FOR 1200A.
5. APPROXIMATE WEIGHT IS 200 LBS (91kg).
6. CIRCUIT BREAKER INSTANTANEOUS TRIP SETTING SHOULD BE SET AT THE MIDPOINT OF THE ADJUSTMENT RANGE FOR 600A - 1200A BREAKERS.

88-797616-07
Rev. 08

CONTROL TERMINALS

ONE-LINE
STANDARD CONNECTIONS

Figure 61 Outline drawing, remote status panel, surface mount

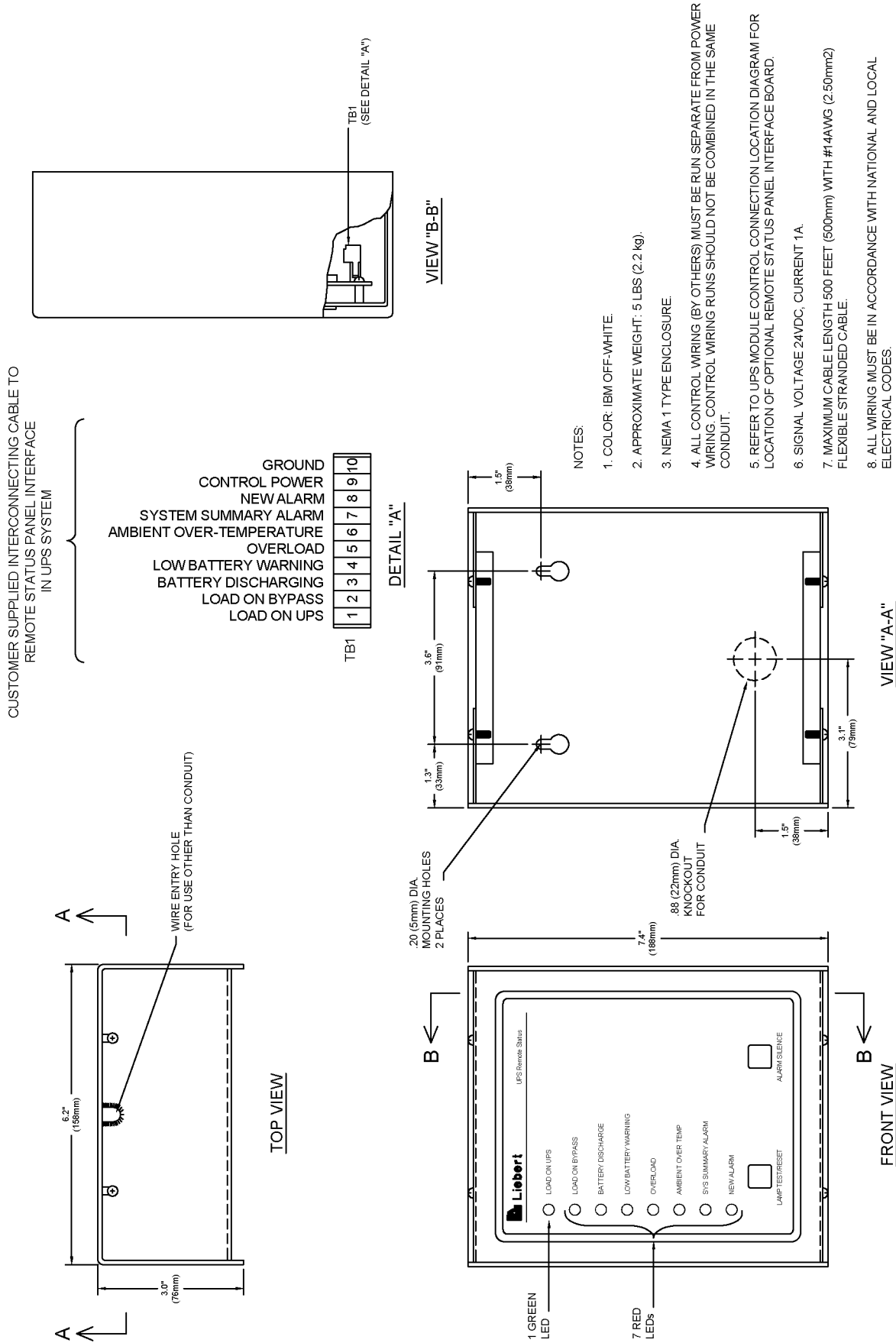

NOTES:

1. COLOR: IBM OFF-WHITE.
2. APPROXIMATE WEIGHT: 5 LBS (2.2 kg).
3. NEMA 1 TYPE ENCLOSURE.
4. ALL CONTROL WIRING (BY OTHERS) MUST BE RUN SEPARATE FROM POWER WIRING. CONTROL WIRING RUNS SHOULD NOT BE COMBINED IN THE SAME CONDUIT.
5. REFER TO UPS MODULE CONTROL CONNECTION LOCATION DIAGRAM FOR LOCATION OF OPTIONAL REMOTE STATUS PANEL INTERFACE BOARD.
6. SIGNAL VOLTAGE 24VDC, CURRENT 1A.
7. MAXIMUM CABLE LENGTH 500 FEET (500mm) WITH #14AWG (2.50mm²) FLEXIBLE STRANDED CABLE.
8. ALL WIRING MUST BE IN ACCORDANCE WITH NATIONAL AND LOCAL ELECTRICAL CODES.

88-791617-01
Rev. 05

APPENDIX A - SITE PLANNING DATA, SERIES 610, 300-450KVA, MULTI-MODULE SYSTEMS

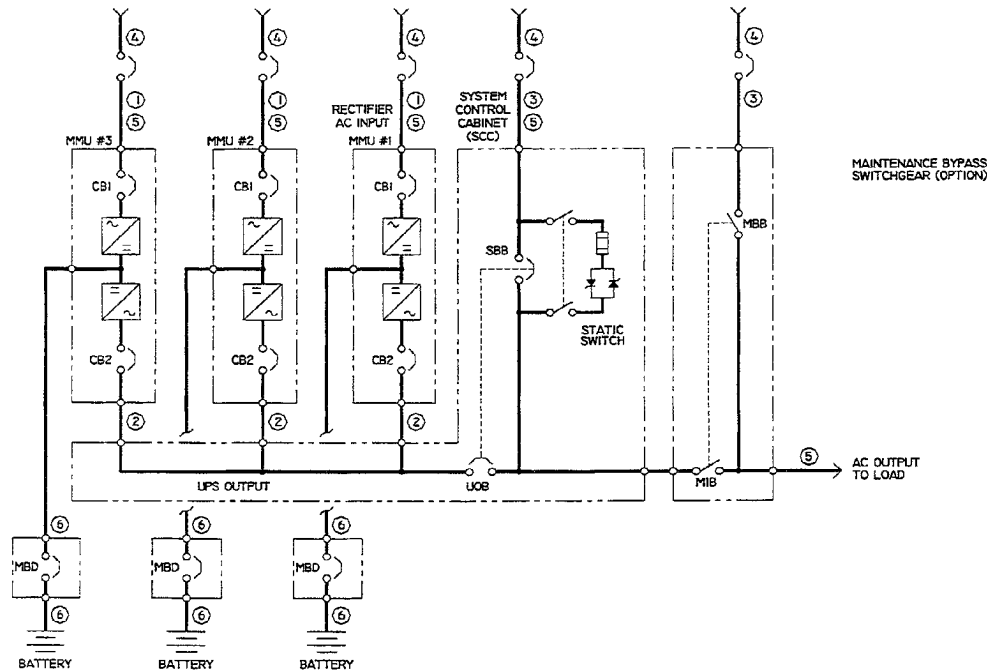

Notes for Tables 6 - 8

1. Nominal rectifier AC input current (considered continuous) is based on full rated output load. Maximum current includes nominal input current and maximum battery recharge current (considered noncontinuous). Continuous and noncontinuous current limits are defined in NEC 100. Maximum input current is controlled by current limit setting which is adjustable. Values shown for maximum setting are 125% of nominal input current. Standard factory setting is 115%.
2. Nominal AC output current (considered continuous) is based on full rated output load. Maximum current includes nominal output current and overload current for 10 minutes.
3. Bypass AC input current (considered continuous) is based on full rated output load.
4. Feeder protection (by others in external equipment) for rectifier AC input and bypass AC input is recommended to be provided by separate overcurrent protection devices.
5. UPS output load cables must be run in separate conduit from input cables.
6. Power cable from module DC bus to battery should be sized for a total maximum 2.0 volt line drop (power cable drop plus return cable drop as measured at the module) at maximum discharge current.
7. Grounding conductors to be sized per NEC 250-122. Neutral conductors to be sized for full capacity—per NEC 310-15 (b)(4)—for systems with 4-wire loads and half capacity for systems with 3-wire loads.

(7 continued)

- NOTE:** A neutral conductor is required from each Multi-Module Unit output to the System Control Cabinet and from each SCC to the Power-Tie™ cabinet, if applicable. See grounding diagrams in the Installation Manual.
8. Rectifier AC Input: 3-phase, 3-wire, plus ground
AC Output to Load: 3-phase, 3- or 4-wire, plus ground
Bypass AC Input to SCC: 3-phase, 3- or 4-wire, plus ground
Module DC Input from Battery: 2-wire (positive and negative), plus ground
Module Input to SCC: 3-phase, 4-wire, plus ground
 9. All wiring is to be in accordance with National and Local Electrical Codes.
 10. Minimum overhead clearance is 2 ft. (0.6m) above the UPS.
 11. Top or bottom cable entry through removable access plates. Cut plate to suit conduit size.
 12. Control wiring and power cables must be run in separate conduits. Control wiring must be stranded tinned conductors.
 13. 7% maximum reflected input harmonic current and 0.92 lagging input power factor at full load with optional input filter.
 14. Dimensions and weights do not include the System Control Cabinet required for Multi-Module Systems.

Table 6 Site planning data—600V input

UPS Rating		AC Output Voltage	Options		Rectifier AC Input Current		Inverter Output Current		Required Battery Disconnect Rating (A)	Max. Battery Current at End of Discharge (A)	Max. Heat Dissipation Full Load BTU/h (kWH)	Dimensions	Approx. Weight Unpacked	Floor Loading Concentrated Loading
kVA	kW	VAC	Input Filter	Input Xformer	Nom	Max	Nom	Max				WxDxH: in. (mm)	lb. (kg)	lb./ft. 2 (kg/m ²)
300	240	600	NO	NO	291	363	289	361	600	648	56,950 (16.7)	72x35x78 (1829x889x1981)	4550 (2064)	260 (1269)
300	240	600	YES	NO	269	337	289	361	600	648	59,750 (17.5)		4720 (2141)	270 (1318)
300	240	600	NO	YES	295	369	289	361	600	648	71,250 (20.9)	96x35x78 (2438x889x1981)	6450 (2926)	276 (1348)
300	240	600	YES	YES	274	342	289	361	600	648	74,150 (21.7)		6620 (3003)	284 (1387)
300	240	208	NO	NO	292	365	833	1041	600	651	61,650 (18.1)	72x35x78 (1829x889x1981)	5000 (2268)	286 (1396)
300	240	208	YES	NO	271	338	833	1041	600	651	64,500 (18.9)		5170 (2345)	295 (1440)
300	240	208	NO	YES	297	371	833	1041	600	651	76,100 (22.3)	96x35x78 (2438x889x1981)	7100 (3221)	304 (1484)
300	240	208	YES	YES	275	344	833	1041	600	651	79,050 (23.1)		7270 (3298)	312 (1523)
400	320	600	NO	NO	387	484	385	481	800	864	75,950 (22.2)	72x35x78 (1829x889x1981)	5350 (2427)	306 (1494)
400	320	600	YES	NO	359	449	385	481	800	864	79,700 (23.3)		5520 (2504)	315 (1538)
400	320	600	NO	YES	394	492	385	481	800	864	94,950 (27.8)	96x35x78 (2438x889x1981)	7250 (3289)	311 (1518)
400	320	600	YES	YES	365	456	385	481	800	864	98,855 (28.9)		7420 (3366)	318 (1553)
400	320	208	NO	NO	390	487	1110	1388	800	868	82,200 (24.1)	72x35x78 (1829x889x1981)	6050 (2744)	346 (1689)
400	320	208	YES	NO	361	451	1110	1388	800	868	86,000 (25.2)		6220 (2821)	355 (1733)
400	320	208	NO	YES	396	495	1110	1388	800	868	101,450 (29.7)	96x35x78 (2438x889x1981)	8150 (3697)	349 (1704)
400	320	208	YES	YES	367	459	1110	1388	800	868	105,400 (30.9)		8320 (3774)	357 (1743)
See Notes (p. 83):			13	—	1,4,5,7,8,9,11,12		2,3,5,7,8,9,11,12		6	6,8,9,11,12	—	14	14	—

Table 7 Site planning data—480V input

UPS Rating		AC Output Voltage	Options		Rectifier AC Input Current		Inverter Output Current		Required Battery Disconnect Rating (A)	Max. Battery Current at End of Discharge (A)	Max. Heat Dissipation Full Load BTU/h (kWh)	Dimensions	Approx. Weight Unpacked	Floor Loading Concentrated Loading
kVA	kW	VAC	Input Filter	Input Xformer	Nom	Max	Nom	Max				WxDxH: in. (mm)	lb. (kg)	lb./ft. 2 (kg/m ²)
300	240	480	NO	NO	361	452	361	451	600	648	52,300 (15.3)	72x35x78 (1829x889x1981)	4150 (1882)	237 (1157)
300	240	480	YES	NO	335	419	361	451	600	648	55,100 (16.1)		4320 (1960)	247 (1206)
300	240	480	NO	YES	367	459	361	451	600	648	66,400 (19.4)	96x35x78 (2438x889x1981)	6050 (2744)	259 (1265)
300	240	480	YES	YES	340	425	361	451	600	648	69,300 (20.3)		6220 (2821)	267 (1304)
300	240	208	NO	NO	363	454	833	1041	600	651	56,950 (16.7)	72x35x78 (1829x889x1981)	4400 (1996)	251 (1225)
300	240	208	YES	NO	337	421	833	1041	600	651	59,750 (17.5)		4570 (2073)	261 (1274)
300	240	208	NO	YES	369	461	833	1041	600	651	71,250 (20.9)	96x35x78 (2438x889x1981)	6500 (2948)	279 (1362)
300	240	208	YES	YES	342	428	833	1041	600	651	74,150 (21.7)		6670 (3025)	286 (1396)
300	270	480	NO	NO	406	508	361	451	800	729	58,820 (17.2)	72x35x78 (1829x889x1981)	4420 (2005)	252 (1233)
300	270	480	YES	NO	376	469	361	451	800	729	58,820 (17.2)		4590 (2082)	262 (1281)
300	270	480	NO	YES	413	516	361	451	800	729	74,717 (21.9)	96x35x78 (2438x889x1981)	6050 (2744)	259 (1265)
300	270	480	YES	YES	382	477	361	451	800	729	74,717 (21.9)		6220 (2821)	267 (1304)
400	320	480	NO	NO	482	602	481	601	1000	864	69,700 (20.4)	72x35x78 (1829x889x1981)	4850 (2200)	277 (1352)
400	320	480	YES	NO	447	558	481	601	1000	864	73,450 (21.5)		5020 (2277)	287 (1401)
400	320	480	NO	YES	490	612	481	601	1000	864	88,550 (25.9)	96x35x78 (2438x889x1981)	6750 (3062)	289 (1411)
400	320	480	YES	YES	454	567	481	601	1000	864	92,400 (27.1)		6920 (3139)	297 (1450)
400	320	208	NO	NO	484	605	1110	1388	1000	868	75,950 (22.2)	72x35x78 (1829x889x1981)	5100 (2313)	291 (1421)
400	320	208	YES	NO	449	561	1110	1388	1000	868	79,700 (23.3)		5270 (2390)	301 (1470)
400	320	208	NO	YES	492	615	1110	1388	1000	868	94,950 (27.8)	96x35x78 (2438x889x1981)	7200 (3266)	309 (1509)
400	320	208	YES	YES	456	570	1110	1388	1000	868	98,850 (28.9)		7370 (3343)	316 (1543)
400	360	480	NO	NO	542	677	481	601	1000	972	78,450 (23.0)	72x35x78 (1829x889x1981)	5050 (2291)	289 (1411)
400	360	480	YES	NO	502	628	481	601	1000	972	82,600 (24.2)		5220 (2368)	298 (1455)
400	360	480	NO	YES	551	688	481	601	1000	972	99,600 (29.2)	96x35x78 (2438x889x1981)	7550 (3425)	324 (1582)
400	360	480	YES	YES	510	638	481	601	1000	972	103,950 (30.4)		7720 (3502)	331 (1616)
450	360	480	NO	NO	542	677	541	677	1000	972	78,450 (23.0)	72x35x78 (1829x889x1981)	5050 (2291)	289 (1411)
450	360	480	YES	NO	502	628	541	677	1000	972	82,600 (24.2)		5220 (2368)	298 (1455)
450	360	480	NO	YES	551	688	541	677	1000	972	99,600 (29.2)	96x35x78 (2438x889x1981)	7550 (3425)	324 (1582)
450	360	480	YES	YES	510	638	541	677	1000	972	103,950 (30.4)		7720 (3502)	331 (1616)
See Notes (p. 83):			13	—	1,4,5,7,8,9,11,12		2,3,5,7,8,9,11,12		6	6,8,9,11,12	—	14	14	—

Table 8 Site planning data—208V input

UPS Rating		AC Output Voltage	Options		Rectifier AC Input Current		Inverter Output Current		Required Battery Disconnect Rating (A)	Max. Battery Current at End of Discharge (A)	Max. Heat Dissipation Full Load BTU/h (kWH)	Dimensions	Approx. Weight Unpacked	Floor Loading Concentrated Loading
kVA	kW	VAC	Input Filter	Input Xformer	Nom	Max	Nom	Max				WxDxH: in. (mm)	lb. (kg)	lb./ft. ² (kg/m ²)
300	240	208	NO	NO	847	1059	833	1041	600	651	66,400 (19.4)	72x35x78 (1829x889x1981)	5350 (2427)	306 (1494)
300	240	208	YES	NO	785	982	833	1041	600	651	69,300 (20.3)		5520 (2504)	315 (1538)
300	240	208	NO	YES	861	1077	833	1041	600	651	81,000 (23.7)	96x35x78 (2438x889x1981)	7450 (3379)	319 (1557)
300	240	208	YES	YES	798	998	833	1041	600	651	84,000 (24.6)		7620 (3456)	327 (1597)
See Notes (p. 83):			13	—	1,4,5,7,8,9,11,12		2,3,5,7,8,9,11,12		6	6,8,9,11,12	—	14	14	—

System Control Cabinets

Multi-Module Systems are provided with a System Control Cabinet. Cabinets are available to match load current. **Table 9** shows dimensions and weights for SCCT cabinets.

Table 9 System Control Cabinet data - SCCT

Type	Amps	Overall dimensions - WxDxH: in. (mm)	Weight - lb. (kg)
SCCT	360-1200	37x37x78 (940x940x1981)	1000 (454)
SCCT	1600	62x48x78 (1575x1219x1981)	1525 (692)
SCCT	2000	62x48x78 (1575x1219x1981)	2850 (1293)
SCCT	2500-3000	62x60x78 (1575x1524x1981)	3100 (1406)
SCCT	4000	138x60x78 (3505x1524x1981)	5850 (2653)

NOTES

Ensuring The High Availability Of Mission-Critical Data And Applications.

Emerson Network Power, the global leader in enabling business-critical continuity, ensures network resiliency and adaptability through a family of technologies—including Liebert power and cooling technologies—that protect and support business-critical systems. Liebert solutions employ an adaptive architecture that responds to changes in criticality, density and capacity. Enterprises benefit from greater IT system availability, operational flexibility and reduced capital equipment and operating costs.

Technical Support / Service Web Site

www.liebert.com

Monitoring

liebert.monitoring@emerson.com

800-222-5877

Outside North America: +800 1155 4499

Single-Phase & Three-Phase UPS

liebert.upstech@emerson.com

800-222-5877

Outside North America: +800 1155 4499

Environmental Systems

800-543-2778

Outside the United States: 614-888-0246

Locations

United States

1050 Dearborn Drive

P.O. Box 29186

Columbus, OH 43229

Europe

Via Leonardo Da Vinci 8

Zona Industriale Tognana

35028 Piove Di Sacco (PD) Italy

+39 049 9719 111

Fax: +39 049 5841 257

Asia

29/F, The Orient Square Building

F. Ortigas Jr. Road, Ortigas Center

Pasig City 1605

Philippines

+63 2 687 6615

Fax: +63 2 730 9572

While every precaution has been taken to ensure the accuracy and completeness of this literature, Liebert Corporation assumes no responsibility and disclaims all liability for damages resulting from use of this information or for any errors or omissions.

© 2007 Liebert Corporation

All rights reserved throughout the world. Specifications subject to change without notice.

® Liebert is a registered trademark of Liebert Corporation.

All names referred to are trademarks or registered trademarks of their respective owners.

SL-25135_REV04_07-09

Emerson Network Power.

The global leader in enabling *Business-Critical Continuity*.

■ AC Power

■ Embedded Computing

■ Outside Plant

■ Racks & Integrated Cabinets

■ Connectivity

■ Embedded Power

■ Power Switching & Controls

■ Services

■ DC Power

■ Monitoring

■ Precision Cooling

■ Surge Protection

EmersonNetworkPower.com

Business-Critical Continuity, Emerson Network Power and the Emerson Network Power logo are trademarks and service marks of Emerson Electric Co.

©2007 Emerson Electric Co.