

# Series 600T™ UPS

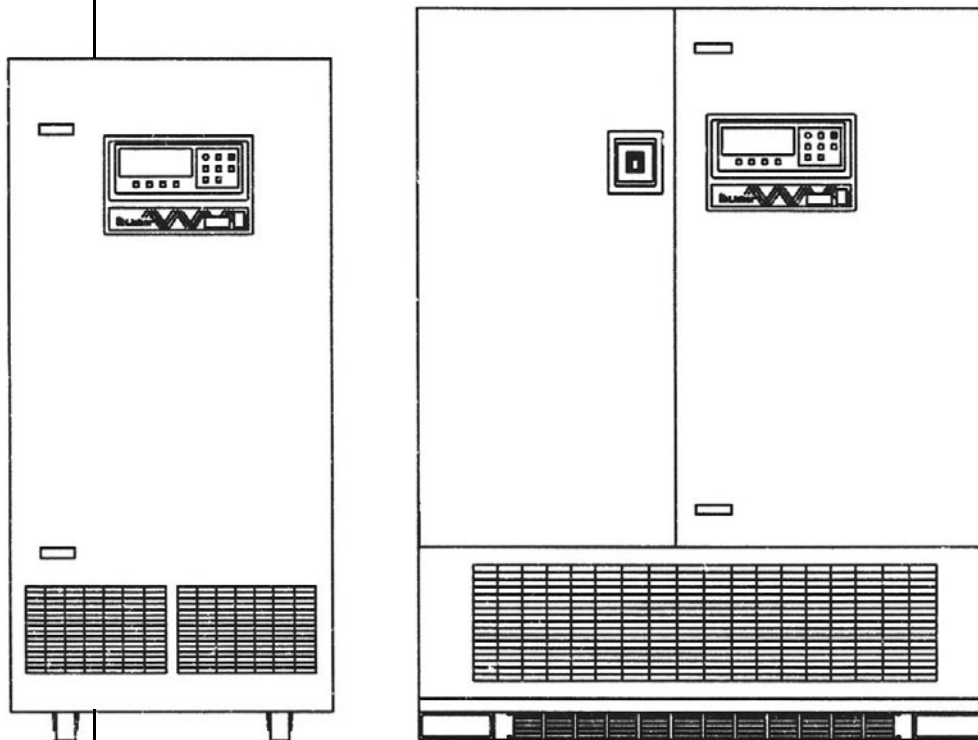

*Single Module  
Three-Phase  
65-225 kVA  
60 Hz*

---

The following **WARNING** applies to all battery cabinets supplied with UPS systems:

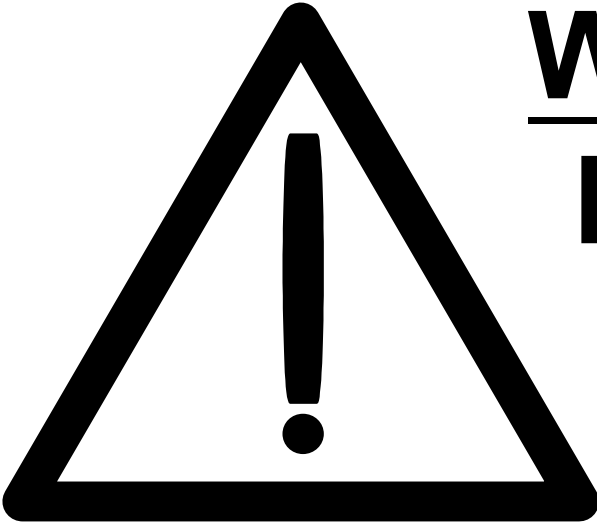

# **WARNING** **HAZARD**

**INTERNAL BATTERY STRAPPING MUST BE VERIFIED BY MANUFACTURER PRIOR TO MOVING A BATTERY CABINET.**

**Battery cabinets contain non-spillable batteries.**

**Keep units upright.**

**Do not stack.**

**Do not tilt.**

**Failure to heed this warning could result in smoke, fire or electric hazard. Call 1-800-LIEBERT prior to moving battery cabinets.**

---

---

# INSTALLATION MANUAL

## TABLE OF CONTENTS

1.	SAFETY PRECAUTIONS .....	1
2.	INSTALLATION CONSIDERATIONS .....	2
3.	UNLOADING AND HANDLING .....	3
4.	INSPECTIONS .....	3
4.1.	External Inspections .....	3
4.2.	Internal Inspections .....	3
5.	EQUIPMENT LOCATION .....	4
6.	BATTERY INSTALLATION .....	4
6.1.	Battery Safety Precautions .....	4
6.2.	Battery Cabinets .....	6
6.3.	Open-Rack Batteries .....	7
7.	CONFIGURING YOUR NEUTRAL AND GROUND CONNECTIONS .....	7
7.1.	Preferred Grounding Configuration, Isolated Power Distribution Units .....	8
7.2.	Alternative Grounding Configuration, Isolated Power Distribution Units, .....	9
7.3.	Preferred Grounding Configuration, 480 or 600 VAC Input, 208VAC Output .....	10
7.4.	Preferred Grounding Configuration, 208 VAC Input and Output, Non-Isolated Load .....	11
7.5.	Grounding Configuration, Delta Source or Impedance-Grounded Wye .....	12
7.6.	Preferred Grounding Configuration with Power-Tie™ Switchgear .....	13
7.7.	Preferred Grounding Configuration, Battery Systems .....	14
8.	WIRING CONSIDERATIONS .....	15
8.1.	Power Wiring .....	15
8.2.	Control Wiring .....	19
8.3.	Battery Wiring .....	19
9.	WIRING CONNECTIONS .....	20
9.1.	Warnings .....	20
9.2.	Specific Connections .....	20
10.	WIRING INSPECTION .....	21



### WARNING

#### LOCATE CENTER OF GRAVITY SYMBOLS



#### AND DETERMINE UNIT WEIGHT BEFORE HANDLING CABINET

If you require assistance for any reason, call the toll-free Liebert Global Services number, 1-800-543-2378. Please have the following information available:

Part Number: \_\_\_\_\_  
Serial Number: \_\_\_\_\_  
kVA Rating \_\_\_\_\_  
kW Rating \_\_\_\_\_  
Date Purchased \_\_\_\_\_  
Date Installed \_\_\_\_\_  
Location: \_\_\_\_\_  
Input Voltage \_\_\_\_\_  
Output Voltage \_\_\_\_\_  
Battery Reserve Time: \_\_\_\_\_

---

## TABLES

Table 1.	Power Wiring Terminals - Factory Supplied .....	22
Table 2.	Torque Specifications .....	22
Table 3.	Field-Supplied Lugs .....	23
Table 310-16, NEC	Allowable Ampacities of Insulated Conductors.....	24

## FIGURES

Figure 1.	Preferred Grounding Configuration, 480 or 600 VAC input and output .....	8
Figure 2.	Alternative Grounding Configuration, 480 or 600 VAC input and output .....	9
Figure 3.	Preferred Grounding Configuration, 480 or 600 VAC input and 208 VAC output .....	10
Figure 4.	Preferred Grounding Configuration, 208 VAC input and output .....	11
Figure 5.	Preferred Grounding Configuration with Delta Source Input .....	12
Figure 6.	Preferred Grounding Configuration, Power-Tie™ Systems .....	13
Figure 7.	Preferred Battery Cabinet Grounding Configuration .....	14
Figure 8.	Typical One-Line Diagrams for SMS with Standard Dual Input .....	16
Figure 9.	Typical One-Line Diagrams of SMS with optional single input. ....	17
Figure 10.	Typical One-Line Diagrams of SMS with optional Maintenance Bypass Cabinets .....	18
Figure 11.	Outline Drawing Single and Multi Module 65 & 80 kVA .....	25
Figure 12.	Outline Drawing, 100 through 225 kVA Module with SpaceSaver Top-Entry Configuration .....	26
Figure 13.	Outline Drawing, 100 through 225 kVA Module with Standard Top & Bottom Entry .....	27
Figure 14.	Bypass Transformer Cabinet, 65 & 80 kVA .....	28
Figure 15.	Bypass Transformer Cabinet, 100-225 kVA .....	29
Figure 16.	Battery Power Pack, 65 & 80 kVA .....	30
Figure 17.	Battery Power Pack, Size A, 100-225 kVA .....	31
Figure 18.	Outline Drawing, 3-Breaker MBC, 65 & 80 kVA .....	32
Figure 19.	Outline Drawing, 3-Breaker MBC with Bypass Transformer, 65 & 80 kVA .....	33
Figure 20.	Outline Drawing, 3-Breaker MBC, 125-350 Amps .....	34
Figure 21.	Outline Drawing, 3-Breaker MBC, 450 to 800 Amps .....	35
Figure 22.	Outline Drawing, 3-Breaker MBC, 600-800 Amps .....	36
Figure 23.	Line-up Detail, 65 & 80 kVA SMS with Bypass Transformer Cabinet .....	37
Figure 24.	Line-up Detail, 100-225 kVA Space Saver with Bypass Transformer Cabinet .....	38
Figure 25.	Line-up Detail, 100-225 kVA Standard SMS with Bypass Transformer Cabinet .....	39
Figure 26.	Line-up Detail, 65 & 80 kVA SMS with Battery Cabinets .....	40
Figure 27.	Line-up Detail, 100-225 kVA Space Saver with Battery Cabinets .....	41
Figure 28.	Line-up Detail, 100-225 kVA Standard SMS with Battery Cabinets .....	42
Figure 29.	Line-up Detail, 65 & 80 kVA with 3-Breaker MBC .....	43
Figure 30.	Line-up Detail, 65 & 80 kVA with Bypass Transformer and 3-Breaker MBC .....	44
Figure 31.	Line-up Detail, 100-225 kVA Space Saver with 3-Breaker MBC .....	45
Figure 32.	Line-up Detail, 100-225 kVA Space Saver with Bypass Cabinet and 3-Breaker MBC .....	46
Figure 33.	Line-up Detail, 100-225 kVA with 3-Breaker MBC .....	47
Figure 34.	Line-up Detail, 100-225 kVA with Bypass Transformer Cabinet and 3-Breaker MBC .....	48
Figure 35.	Terminal Details, 65 & 80 kVA Single Module Systems .....	49
Figure 36.	Terminal Details, 100 & 125 kVA Space Saver .....	50
Figure 37.	Terminal Details, 150 & 225 kVA Standard SMS .....	51
Figure 38.	Terminal Details, 100 & 125 kVA Standard SMS .....	52
Figure 39.	Terminal Details, 150 & 225 kVA Standard SMS .....	53
Figure 40.	Control Connection Locations, 65 & 80 kVA .....	54
Figure 41.	Control Connection Locations, 100 through 225 kVA .....	55
Figure 42.	Standard Control Wiring, Single Module System .....	56
Figure 43.	Option Wiring, Alarm Status Contacts .....	57
Figure 44.	Option Wiring, Maintenance Bypass Interlock .....	58
Figure 45.	Option Wiring, Remote Status Panel Interface .....	59
Figure 46.	Option Wiring, Remote Terminal IFM (RS-232 Communications) .....	60
Figure 47.	Option Wiring, SiteScan Interface .....	61

---

---

Figure 48. Option Wiring, Customer Alarm Interface . . . . .	62
Figure 49. Option Wiring, Battery Temperature Sensor . . . . .	63
Figure 50. Option Wiring, SNMP Interface . . . . .	64
Figure 51. Option Wiring, Internal Modem . . . . .	65
Figure 52. Option Wiring, Maintenance Bypass Cabinet . . . . .	66
Figure 53. Module Battery Disconnect, 65 through 125 kVA . . . . .	67
Figure 54. Module Battery Disconnect, 150 & 225 kVA . . . . .	68
Figure 55. Remote Status Panel, Surface Mount . . . . .	69
Figure 56. Circuit Breaker Schedule, 65 through 225 kVA . . . . .	70
Figure 57. Circuit Breaker Schedule, Battery Cabinets, 65 to 500 kVA . . . . .	71
Figure 58. Circuit Breaker Schedule, Maintenance Bypass Cabinet, 65 through 225 kVA . . . . .	72

---

---

---

# INSTALLATION

## 1. SAFETY PRECAUTIONS

Read this manual thoroughly, paying special attention to the sections that apply to you, before working with the UPS. **Retain this manual for use by installing personnel.**

Under typical operation and with all UPS doors closed, only normal safety precautions are necessary. The area around the UPS system should be kept free from puddles of water, excess moisture, or debris.

Special safety precautions are required for procedures involving handling, installation, and maintenance of the UPS system or the battery. Observe all safety precautions in this manual before handling or installing the UPS system. Observe all precautions in the **Operation and Maintenance Manual**, before and during performance of all maintenance procedures. Observe all battery safety precautions before working on or near the battery.

**This equipment contains several circuits that are energized with high voltage.** Only test equipment designated for troubleshooting should be used. This is particularly true for oscilloscopes. Always check with an AC and DC voltmeter to ensure safety before making contact or using tools. Even when the power is turned Off, dangerously high potentials may exist at the capacitor banks and at the batteries.

**ONLY qualified service personnel should perform maintenance on the UPS system.** When performing maintenance with any part of the equipment under power, service personnel and test equipment should be standing on rubber mats. The service personnel should wear insulating shoes for isolation from direct contact with the floor (earth ground).

Unless all power is removed from the equipment, one person should never work alone. A second person should be standing by to assist and summon help in case an accident should occur.

Four types of messages are used throughout the manual to stress important text. Carefully read the text below each Danger, Warning, Caution, and Note and use professional skills and prudent care

when performing the actions described by that text.

A **Danger** signals immediate hazards resulting in severe personal injury or death. For example:

---

### DANGER

---

**A DANGER SIGNALS IMMEDIATE HAZARDS WHICH WILL RESULT IN SEVERE PERSONAL INJURY OR DEATH.**

A **Warning** signals the presence of a possible serious, life-threatening condition. For example:

---

### WARNING

---

**LETHAL VOLTAGES MAY BE PRESENT WITHIN THIS UNIT EVEN WHEN IT IS APPARENTLY NOT OPERATING. OBSERVE ALL CAUTIONS AND WARNINGS IN THIS MANUAL. FAILURE TO DO SO COULD RESULT IN SERIOUS INJURY OR DEATH. DO NOT WORK ON OR OPERATE THIS EQUIPMENT UNLESS YOU ARE FULLY QUALIFIED TO DO SO!! NEVER WORK ALONE.**

A **Caution** indicates a condition that could seriously damage equipment and possibly injure personnel. For example:

---

### CAUTION

---

**Extreme care is necessary when removing shoring braces. Do not strike the cabinet with hammers or other tools.**

A **Note** emphasizes important text. If the note is not followed, equipment could be damaged or may not operate properly. For example:

---

### NOTE

---

***If the UPS system has a blown fuse, the cause should be determined before you replace the fuse. Contact Liebert Global Services.***

## 2. INSTALLATION CONSIDERATIONS

Install your Series 600T UPS in accordance with the submittal drawing package and the following procedures.

A Liebert authorized representative must perform the initial system check-out and start-up to ensure proper system operation. Equipment warranties will be voided unless system start-up is performed by a Liebert authorized representative. Contact your local Liebert sales representative or Liebert Global Services at **1-800-543-2378** to arrange for system start-up.

---

### CAUTION

---

**Read this manual thoroughly before attempting to wire or operate the unit. Improper installation is the most significant cause of UPS start-up problems.**

**Do not install this equipment near gas or electric heaters. It is preferable to install the UPS in a restricted location to prevent access by unauthorized personnel.**

1. Proper planning will speed unloading, location, and connection of the UPS. Refer to Figures 11 through 58 and the Site Planning Data (Appendix A).
2. Be certain that the floor at the final equipment location and along the route (inside the facility) to the installation site can support the cabinet weight and the weight of any material handling equipment. The UPS modules can weigh up to two tons. The battery cabinets weigh between 2300 and 5000 pounds each.
3. Plan the routing to ensure that the unit can move through all aisle ways, doorways, and around corners without risking damage. If the modules and batteries must be moved by elevator, check the size of the door openings and the weight-carrying capacity of the elevator.
4. Refer to information later in this manual regarding the optional Battery Cabinet(s), Maintenance Bypass Cabinets, Panelboards and Switchboards. **Observe all battery safety precautions when working on or near the battery.**
5. Use the shortest output distribution cable runs possible, consistent with logical equipment arrangements and with allowances for future additions if planned.
6. Recommended ambient operating temperature is 25°C (77°F). Relative humidity must be less than 95%, non-condensing. Note that room ventilation is necessary, but air conditioning may not be required. Maximum ambient operating temperature for the UPS and switchgear is 40°C (104°F) without derating. The batteries should not exceed 25°C (77°F). At elevations above 4,000 feet (1219 meters) temperature derating may be required for full power output (consult your Liebert sales representative).
7. Even though your Liebert UPS unit is 92.5 to 94% efficient, the heat output is substantial. For more specific information, see the Site Planning Data (Appendix A). Be sure environmental conditioning systems can accommodate this BTU load, even during utility outages.
8. The installer should attempt to balance the load between the three output phases. The UPS will operate safely with an unbalanced load, but will give optimum performance if the three output phases are loaded within 20 percent of each other.



### 3. UNLOADING AND HANDLING

Because the weight distribution in each UPS and ancillary cabinet is uneven, use extreme care during handling and transport. Your installation may also include Battery Cabinets, a Bypass Transformer Cabinet and a Maintenance Bypass Cabinet, Panelboard or Switchboard.

---

#### WARNING

---

**EXERCISE EXTREME CARE WHEN HANDLING UPS CABINETS TO AVOID EQUIPMENT DAMAGE OR INJURY TO PERSONNEL. THE UPS MODULE CAN WEIGH UP TO TWO TONS. THE BATTERY CABINETS WEIGH UP TO 5100 POUNDS.**

**THE UPS MODULES ARE HEAVIER IN THE BACK THAN THE FRONT BECAUSE OF THE WEIGHT OF THE MAGNETICS. LOCATE CENTER OF GRAVITY SYMBOLS BEFORE HANDLING CABINET. TEST LIFT AND BALANCE THE CABINET BEFORE TRANSPORTING. MAINTAIN MINIMUM TILT FROM VERTICAL AT ALL TIMES.**

---

#### WARNING

---

**INTERNAL BATTERY CABINET STRAPPING MUST BE VERIFIED BY MANUFACTURER PRIOR TO MOVING THIS UNIT.**

**THIS UNIT CONTAINS NON-SPILLABLE BATTERIES. KEEP UNIT UPRIGHT. DO NOT STACK. DO NOT TIP.**

**FAILURE TO HEED THIS WARNING COULD RESULT IN SMOKE, FIRE OR ELECTRICAL HAZARD. CALL 1-800-LIEBERT PRIOR TO RELOCATING BATTERY CABINET (AFTER INITIAL INSTALLATION).**

### 4. INSPECTIONS

#### 4.1. External Inspections

1. While the UPS system is still on the truck, inspect the equipment and shipping container(s) for any signs of damage or mishandling. Do not attempt to install the system if damage is apparent. If any damage is noted, file a damage claim with the shipping agency within 24 hours and contact Liebert Global Services at **1-800-543-2378** to inform them of the damage claim and the condition of the equipment.
2. Locate the bag containing the keys for the front access door. The bag is attached to the cabinet.
3. Compare the contents of the shipment with the bill of lading. Report any missing items to the carrier and to Liebert Global Services immediately.
4. Check the nameplate on the cabinet to verify that the model number corresponds with the one specified. Record the model number and serial number in the front of this installation manual. A record of this information is necessary should servicing become required.

#### 4.2. Internal Inspections

1. Verify that all items have been received.
2. If spare parts were ordered, verify arrival.
3. Open doors and remove cabinet panels to check for shipping damage to internal components.
4. Check for loose connections or unsecured components in the cabinet(s).
5. Check for installation of circuit breaker line safety shields. There should be no exposed circuit breaker terminals when the cabinet doors are opened.
6. Remove any orange shipping braces or brackets from the transformers.
7. Check for any unsafe condition that may be a potential safety hazard.

## 5. EQUIPMENT LOCATION

1. Handle cabinet(s) in accordance with **WARNINGS in Section 3**. Use a suitable material handling device to move each cabinet to its final location. **Exercise extreme care because of the uneven weight distribution**. Carefully lower the cabinets to the floor and position them for reconnection, if applicable.
2. Verify that the UPS system is installed in a clean, cool and dry location. Observe the location of overhead water lines for fire sprinkler systems. Avoid placing the UPS and related equipment directly under water lines or within range of a sprinkler head.
3. Installation and serviceability will be easier if adequate access is provided on all sides of the equipment, but only front access is required.
  - a. Verify that there is adequate clearance to open cabinet doors (4 feet is recommended). See drawings and local codes.
  - b. Verify that there is adequate area in front of circuit breakers to perform maintenance. Check installation drawings for location of breakers. Check with local codes.
  - c. Verify that there is adequate clearance above all cabinets to allow exhaust air to flow without restriction (2 feet minimum, unobstructed).
4. Connect the cabinets, internal cables and bus bars, if applicable.

## 6. BATTERY INSTALLATION

### 6.1. Battery Safety Precautions

Battery installation and servicing should be performed or supervised by personnel knowledgeable of batteries and the required precautions. Keep unauthorized personnel away from batteries.

Be sure to observe the grounding recommendations in Section 7 when installing batteries. When replacing batteries, use the same number and type of batteries.

---

### CAUTION

---

**Lead-acid batteries contain hazardous materials. Batteries must be handled, transported, and recycled or discarded in accordance with federal, state, and local regulations. Because lead is a toxic substance, lead-acid batteries should be recycled rather than discarded.**

**Do not open or mutilate the battery or batteries. Released electrolyte is harmful to the skin and eyes. It may be toxic. Do not dispose of battery or batteries in a fire. The battery may explode.**

**A battery can present a risk of electrical shock and high short-circuit current. The following precautions should be observed when working on batteries:**

1. **Remove watches, rings, or other metal objects.**
2. **Use tools with insulated handles.**
3. **Wear rubber gloves and boots.**
4. **Do not lay tools or metal parts on top of batteries.**
5. **Disconnect charging source prior to connecting or disconnecting battery terminals.**
6. **Determine if the battery is inadvertently grounded. If it is inadvertently grounded, remove source of ground. Contact with any part of a grounded battery can result in electrical shock. The likelihood of such shock will be reduced if such grounds are removed during installation and maintenance.**

**Lead-acid batteries can present a risk of fire because they generate hydrogen gas. The following procedures should be followed:**

1. **DO NOT SMOKE when near batteries.**
2. **DO NOT cause flame or spark in battery area.**
3. **Discharge static electricity from body before touching batteries by first touching a grounded metal surface.**

## **BATTERY SAFETY PRECAUTIONS IN FRENCH PER CSA REQUIREMENTS**

### **INSTRUCTIONS IMPORTANTES CONCERNANT LA SÉCURITÉ**

#### **CONSERVER CES INSTRUCTIONS**

#### **AVERTISSEMENT**

DES PIÈCES SOUS ALIMENTATION SERONT LAISSÉES SANS PROTECTION DURANT CES PROCÉDURES D'ENTRETIEN. UN PERSONNEL QUALIFIÉ EST REQUIS POUR EFFECTUER CES TRAVAUX.

LES FUSIBLES A C.C. DE LA BATTERIE D'ACCUMULATEURS OPERENT EN TOUT TEMPS A LA TENSION NOMINALE. LA PRESENCE D'UN FUSIBLE A C.C. BRULE INDIQUE UN PROBLEME SERIEUX. LE REMPLACEMENT DE CE FUSIBLE, SANS AVOIR DETERMINE LES RAISONS DE LA DEFECTUOSITE, PEUT ENTRAINER DES BLESSURES OU DES DOMMAGES SERIEUX A L'EQUIPEMENT. POUR ASSISTANCE, APPELER LE DEPARTEMENT DE SERVICE A LA CLIENTELE DE LIEBERT.

#### **DANGER**

Les accumulateurs plomb-acide contiennent de la matière comportant un certain risque. Les accumulateurs doivent être manipulés, transportés et recyclés ou éliminés en accord avec les lois fédérales, provinciales et locales. Parce que le plomb est une substance toxique, les accumulateurs plomb-acide devraient être recyclés plutôt qu'éliminés.

Il ne faut pas brûler le ou les accumulateurs. L'accumulateur pourrait alors exploser.

Il ne faut pas ouvrir ou endommager le ou les accumulateurs. L'électrolyte qui pourrait s'en échapper est dommageable pour la peau et les yeux.

Un accumulateur représente un risque de choc électrique et de haut courant de court-circuit. Lorsque des accumulateurs sont manipulés, les mesures préventives suivantes devraient être observées:

1. Retirer toutes montres, bagues ou autres objets métalliques.
2. Utiliser des outils avec manchon isolé.
3. Porter des gants et des bottes de caoutchouc.

4. Ne pas déposer les outils ou les pièces métalliques sur le dessus des accumulateurs.
5. Interrompre la source de charge avant de raccorder ou de débrancher les bornes de la batterie d'accumulateurs.
6. Déterminer si l'accumulateur est mis à la terre par erreur. Si oui, défaire cette mise à la terre. Tout contact avec un accumulateur mis à la terre peut se traduire en un choc électrique. La possibilité de tels chocs sera réduite si de telles mises à la terre sont débranchées pour la durée de l'installation ou de l'entretien.

Les accumulateurs plomb-acide présentent un risque d'incendie parce qu'ils génèrent des gaz à l'hydrogène. Les procédures suivantes devront être respectées.

1. NE PAS FUMER lorsque près des accumulateurs.
2. NE PAS produire de flammes ou d'étincelles près des accumulateurs.
3. Décharger toute électricité statique présente sur votre corps avant de toucher un accumulateur en touchant d'abord une surface métallique mise à la terre.

#### **DANGER**

L'électrolyte est un acide sulfurique dilué qui est dangereux au contact de la peau et des yeux. Ce produit est corrosif et aussi conducteur électrique. Les procédures suivantes devront être observées:

1. Porter toujours des vêtements protecteurs ainsi que des lunettes de protection pour les yeux.
2. Si l'électrolyte entre en contact avec la peau, nettoyer immédiatement en rinçant avec de l'eau.
3. Si l'électrolyte entre en contact avec les yeux, arroser immédiatement et généreusement avec de l'eau. Demander pour de l'aide médicale.
4. Lorsque l'électrolyte est renversée, la surface affectée devrait être nettoyée en utilisant un agent neutralisant adéquat. Une pratique courante est d'utiliser un mélange d'approximativement une livre (500 grammes) de bicarbonate de soude dans approximativement un gallon (4 litres) d'eau. Le mélange de bicarbonate de soude devra être ajouté jusqu'à ce qu'il n'y ait plus apparence de réaction (mousse). Le liquide résiduel devra être nettoyé à l'eau et la surface concernée devra être asséchée.

## 6.2 Battery Cabinets

Optional battery cabinets are available from Liebert and other qualified vendors. Consult your submittal package for details.

The same model battery cabinet may be paralleled in multiple cabinet strings for additional capacity. Battery capacity (in minutes) at your installation will depend on cabinet model, number of cabinets, and amount of critical load on the UPS.

- 1. Handling.** The Battery Cabinet weighs up to 5100 pounds. Fork lift slots are provided in the base of 100-225 kVA cabinets for easy handling. Fork lift forks or a pallet jack can be used between the casters of the 65 and 80 kVA battery cabinets.
- 2. Cabinet Inspection.** Remove all panels and visually inspect the batteries, bus connections, and cabinet for any damage. If any foam blocks were placed between shelves to restrain movement during shipment, remove them now. **Exercise caution; voltage is present within the Battery Cabinet even before installation.** If there are signs of damage, do not proceed. Call Liebert Global Services at **1-800-542-2378**.
- 3. Battery Storage.** The batteries used in the Battery Cabinet retain their charge well. The batteries can be stored for up to six months without any appreciable deterioration. Self-discharge rate of the batteries is approximately 3% per month when the batteries are stored in temperatures of 15°C to 25°C (59°F to 77°F). If the Battery Cabinet must be stored for longer than six months, contact Liebert Global Services.
- 4. Installation.** The Battery Cabinet(s) can be located conveniently to the left side of the 65-225 kVA UPS module. The front-access-only-design eliminates side and rear service clearance requirements.
- 5. Re-Installation.** If it later becomes necessary to move the Battery Cabinet to another location, contact Liebert Global Services to inspect the internal battery hold-down straps.
- 6. Environment.** Locate the Battery Cabinet in a clean, dry environment. Recommended temperature range for optimum performance and lifetime is 20-25°C (68-77°F).
- 7. Service Clearance.** Allow front access to the Battery Cabinet at all times for maintenance and servicing. Electrical codes require that the Battery Cabinet be installed with no less than 3 feet (1 meter) of clearance at the front of the cabinet when operating. Side and rear panels do not require service clearance.
- 8. Side Panels.** Remove protective side panels to connect battery cabinets together. Do not remove the shield plate, explained below.
- 9. Shield Plate.** The shield plate in 125 kVA Battery Cabinets should be on the side toward the UPS system. Move the shield if required by your Battery Cabinet location.
- 10. Cables.** Cables may be run between battery cabinets through cutouts in the top of the cabinets, eliminating the need for external conduit runs. **Route cables before moving cabinets into final position for bolting together.** Remove top panels for access. Refer to Figures 16 and 17 or your submittal drawings for instructions on wiring cabinets in parallel.
- 11. Grounding.** The battery cabinets have ground studs near the bus bar connections. Use an equipment grounding conductor to connect the lugs of the cabinets together and to connect the cabinets to the ground bus bar in the UPS module.

---

### CAUTION

---

**Cables between batteries and modules should be run in matched pairs, positive-with-negative. Grouping like-polarity cables together (i.e. positive-with-positive and negative-with-negative) can cause stress or damage to the cables, conduit or buswork.**

### 6.3 Open-Rack Batteries

When batteries other than Liebert Battery Cabinets are used, a remote battery disconnect switch with overcurrent protection is required per the National Electrical Code. Refer to Figures 53 and 54. Contact your Liebert sales representative.

1. Install battery racks/cabinets and batteries per manufacturer's installation and maintenance instructions.
2. Verify battery area has adequate ventilation and battery operating temperature complies with manufacturer's specification.
3. Ensure that battery racks are properly grounded according to code requirements in your area.

If you have any questions concerning batteries, battery racks, or accessories, contact Liebert Global Services at **1-800-543-2378**.

---

#### CAUTION

---

**Cables between batteries and modules should be run in matched pairs, positive-with-negative. Grouping like-polarity cables together (i.e. positive-with-positive and negative-with-negative) can cause stress or damage to the cables, conduit or buswork.**

### 7. CONFIGURING YOUR NEUTRAL AND GROUND CONNECTIONS

Improper grounding is the largest single cause of UPS installation and start-up problems. This is not an easy subject, since grounding techniques vary significantly from site to site, depending on several factors. The questions you should ask are:

- What is the configuration of the input power source? Most of the recommended schemes for UPS grounding require grounded-wye service. The UPS system requires a bypass neutral for sensing and monitoring the quality of the bypass input. If the building service is ungrounded delta or corner-grounded delta, contact your Liebert representative to ensure your system includes the Artificial Neutral or Isolated Neutral kit.
- Does the system have a bypass isolation transformer? Systems with 480 VAC (or 600 VAC) input and 208 VAC output require a bypass isolation transformer. In some cases, it may be necessary to treat that transformer as a “separately derived source” with its own grounding electrode. See page 10 for details.
- What are the UPS input and output voltages? Systems with 480 VAC input and output have significantly different needs than systems with 480/208 VAC or 208/208 VAC.
- What is the connected load? Does the critical load consist of one or more Power Distribution Units (PDUs)? Do the PDUs have isolation transformers?

The following sections discuss recommended grounding procedures for various system configurations.

---

#### NOTE

---

***Some UPS modules are equipped with input isolation transformers. However, these transformers have no effect upon any system grounding considerations. These modules will be grounded exactly as shown in the following examples.***

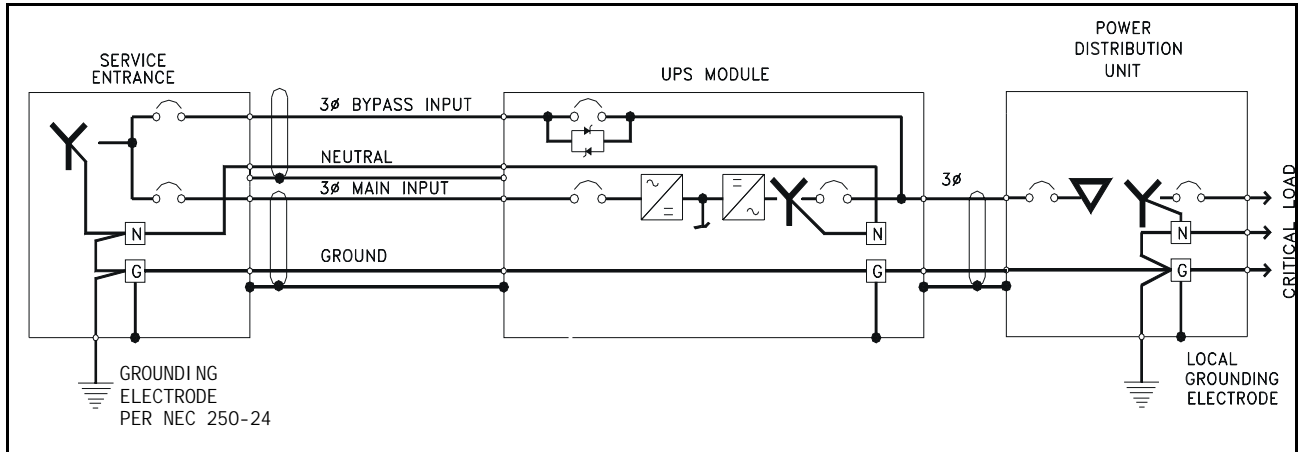

Figure 1. Preferred Grounding Configuration, 480 or 600 VAC input and output

### 7.1. Preferred Grounding Configuration, 480 or 600 VAC Input and Output, Isolated Power Distribution Units, Wye-Connected Service

One of the most-common configurations of the Series 600T UPS is the Single Module System with 480 VAC input, 480 VAC output, and a connected load consisting of multiple Power Distribution Units (PDUs) with isolation transformers in the PDUs to produce 208 VAC. For Canadian customers, the UPS modules usually have 600 VAC input and output. The same principles apply if the connected load is an isolation transformer feeding various loads. Figure 1 above shows a typical installation.

Notice that the UPS module main input and bypass input are connected to a grounded-wye service. In this configuration, the UPS module is not considered a separately derived source. The UPS module output neutral is solidly connected to the building service neutral, which is bonded to the grounding conductor at the service entrance equipment

The isolation transformers in the PDUs are considered a separately derived source. Therefore the PDU neutral should be bonded to the PDU grounding conductor and connected to a local grounding electrode in compliance with NEC 250-26.

Advantages of this configuration include:

- A measure of common-mode noise attenuation, since the isolation (common-mode rejection) occurs as close to the load as practical (i.e. at the PDU).
- The UPS module can be located remotely from the PDU without compromising common-mode noise performance.
- By using UPS modules with 480 VAC input and output and creating 208 VAC at the PDU, smaller and less costly power feeders can be used and less voltage drop (as a percent of nominal) occurs.

#### NOTE

***Impedance-grounded wye sources must be grounded in accordance with Section 7.5.***

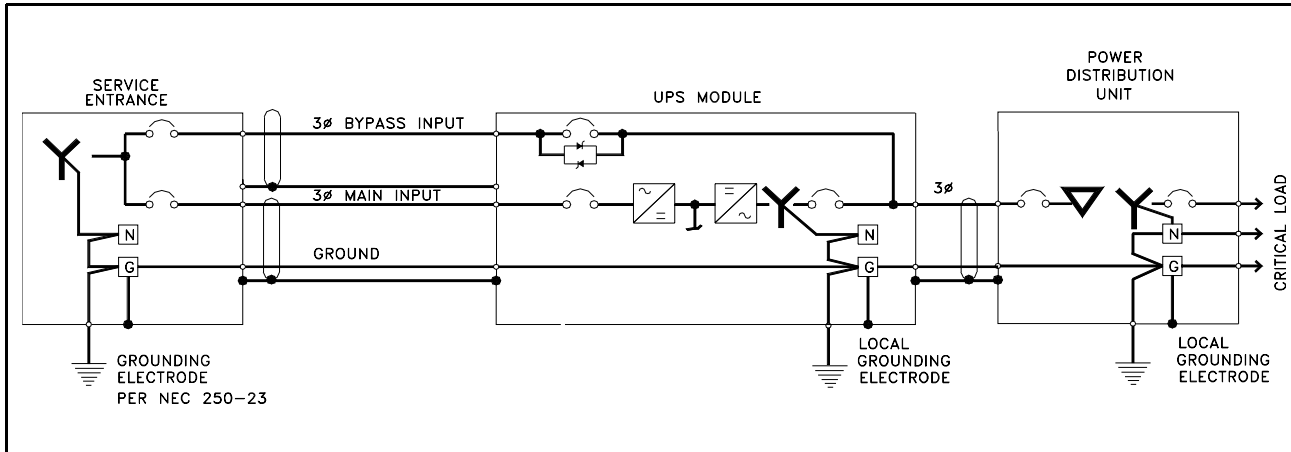

Figure 2. Alternative Grounding Configuration, 480 or 600 VAC input and output

## 7.2 Alternative Grounding Configuration, 480 or 600 VAC Input and Output, Isolated Power Distribution Units, Wye-Connected Service

This configuration is similar to that shown in Section 7.1, except that the service entrance neutral is not brought into the UPS module. In this configuration, the UPS output transformer is considered a separately derived source. The UPS module neutral is bonded to the UPS ground, which is connected to a local grounding electrode in accordance with NEC 250-26.

Please note that this configuration represents a price/performance trade-off. Whenever the UPS module transfers to or from bypass, two AC sources (input and bypass) are briefly connected together and circulating current must flow. In the previous configuration, the current flows through the neutral conductor. In this configuration, the current flows through the ground path, possibly tripping ground fault interruptors (GFIs) and distorting the bypass waveform reference. Proper adjustment of ground fault interruptors is necessary to avoid unwanted tripping.

This configuration is reserved for those applications which meet all the following criteria:

- The facility has Wye-connected service
- The module rectifier input and bypass input are fed from the same source
- The connected load is strictly 3-wire (such as one or more PDUs) and does not require a neutral from the UPS
- Special precautions are taken to prevent tripping the ground fault interruptors. The time delay should be set to at least 30 cycles to prevent tripping when the UPS performs a transfer or retransfer operation.

---

### CAUTION

---

**Failure to properly set the ground fault interruptors could cause loss of power to the critical load.**

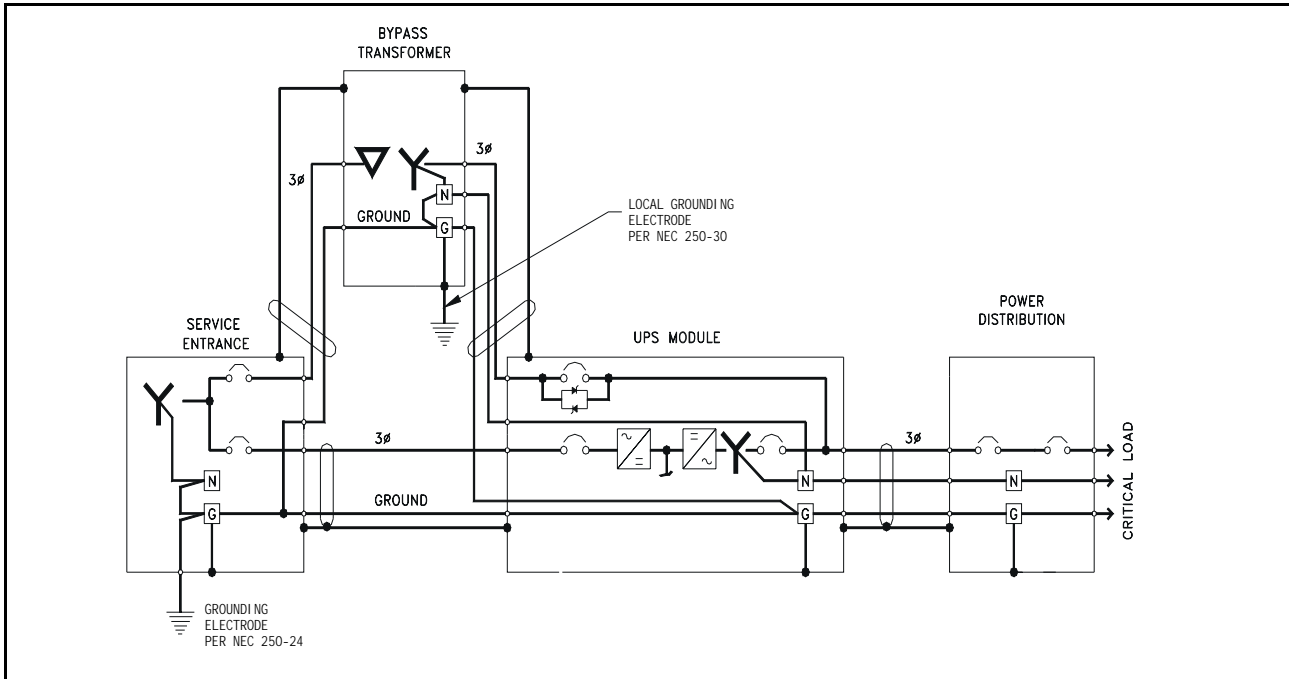

Figure 3. Preferred Grounding Configuration, 480 or 600 VAC input and 208 VAC output

### 7.3. Preferred Grounding Configuration, 480 or 600 VAC Input, 208VAC Output, and Isolated Bypass

Another configuration in this power range is the Single Module System with 480 or 600 VAC input, 208 VAC output, a Bypass Isolation Transformer and a connected load consisting of multiple distribution panelboards or switchboards. Figure 3 above shows a typical installation.

The Bypass Transformer provides isolation and steps down the voltage to the bypass inputs. The Bypass Transformer and the UPS module together constitute a separately derived system, since there is no direct electrical connection between the input (service entrance) circuit conductors and the output circuit conductors.

#### NOTE

*The illustration above shows a wye-connected source, but the same grounding scheme would apply for a delta source at the service entrance.*

The bonding of the neutral to the grounding conductor can theoretically be done at either the UPS module or the Bypass Transformer. However, we recommend bonding at the Bypass Transformer because the UPS module will sometimes be powered down for maintenance and its output transformer will be out of the circuit. The neutral should be bonded to ground and a local grounding electrode should be installed at the Bypass Transformer, per NEC 250-30.

Features of this configuration include:

- The UPS receives its bypass neutral from the Bypass Transformer
- The output is isolated from the input circuit conductors, and
- Some amount of common-mode noise attenuation can be obtained for sensitive loads *if* the UPS module and Bypass Transformer are located close to sensitive loads.



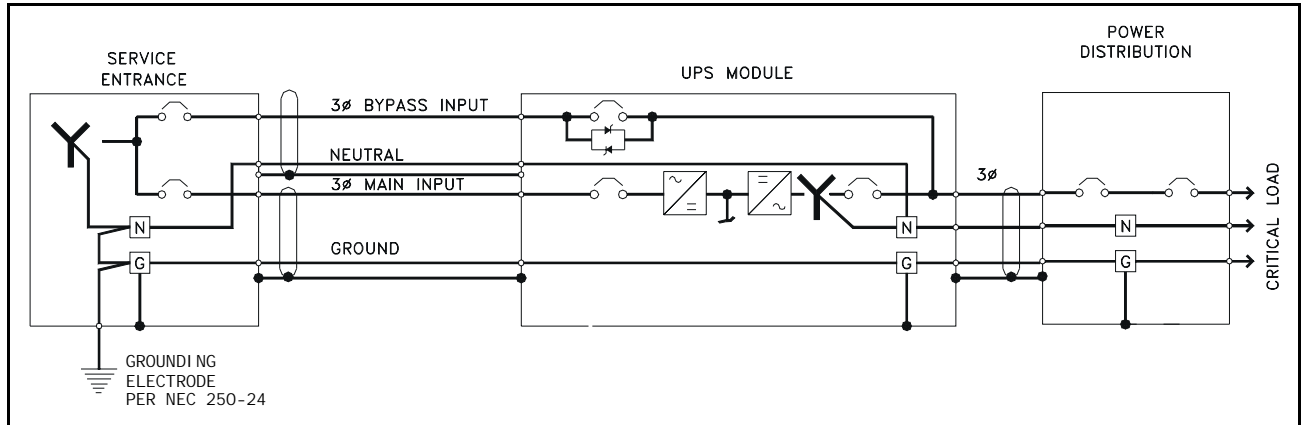

Figure 4. Preferred Grounding Configuration, 208 VAC input and output

#### 7.4. Preferred Grounding Configuration, 208 VAC Input and Output, Non-Isolated Load, Wye-Connected Service

A few applications in this power range have 208 VAC input and output, and a connected load consisting of multiple Power Distribution Units (PDUs), panelboards, switchboards or other items of load equipment which do not have isolation transformers.

Notice in Figure 4 above that the UPS module main input and bypass input are connected to a grounded-wye service. In this configuration, the UPS module is not considered a separately derived source.

The UPS module output neutral and the load neutral are solidly connected to the building service neutral, which is bonded to the grounding conductor at the service entrance equipment.

This arrangement is typical for systems with 208 VAC input and output. However, it does not provide any isolation or common-mode noise attenuation for sensitive loads.

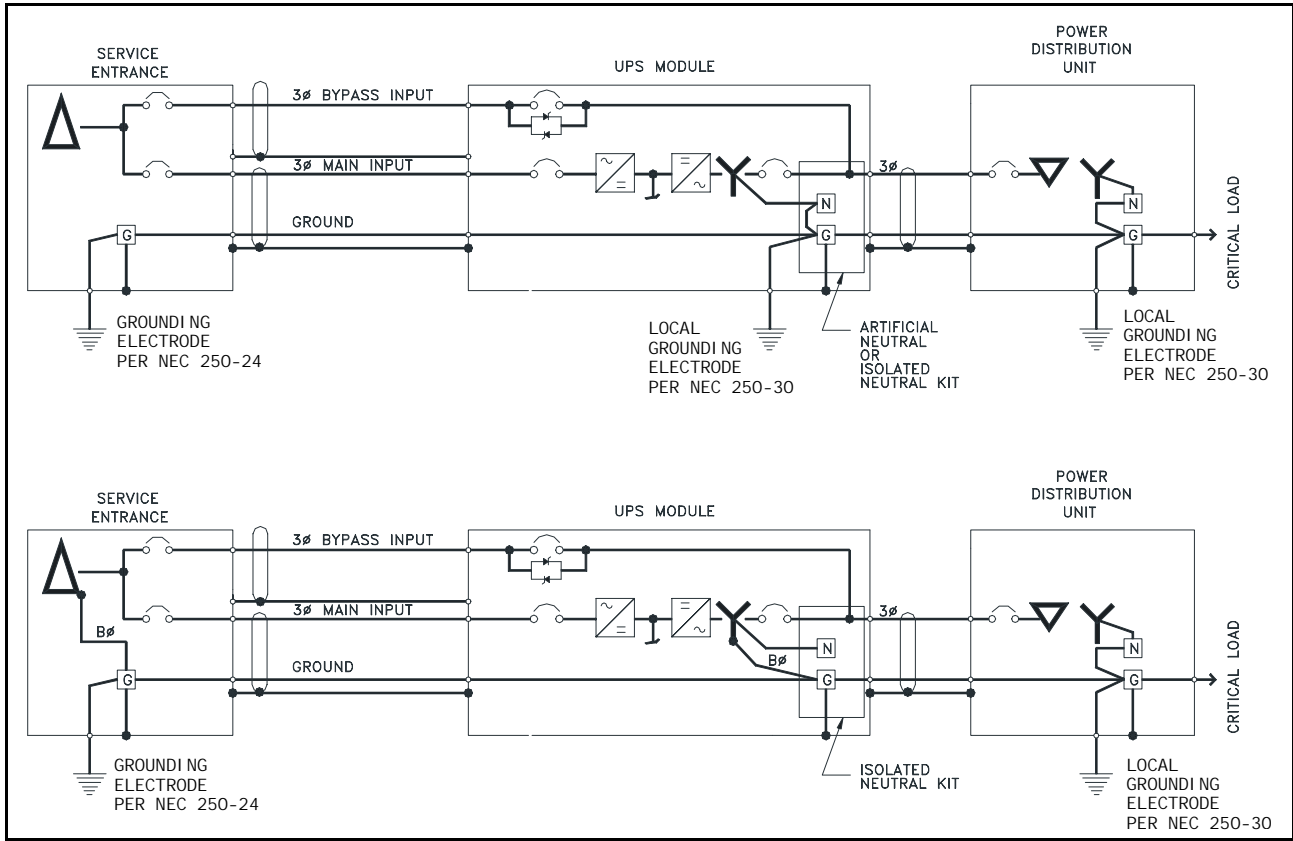

Figure 5. Preferred Grounding Configuration with Ungrounded Delta Source Input (top) and Corner-Grounded Delta (bottom)

### 7.5. Grounding Configuration, 480 or 600 VAC Input and Output, Delta Source or Impedance-Grounded Wye

As previously mentioned, Series 600T UPS modules require a bypass input neutral for sensing and monitoring. With a wye-connected input source, the installer should always connect the building service neutral to the module output neutral to achieve this. When the building service is delta-connected, however, the installer must take special steps to ensure reliable UPS functioning.

If building service is ungrounded delta (and there is no intent to operate with one corner of the delta grounded, either on purpose or accidentally), the UPS requires the Series 600T Artificial Neutral Kit for proper operation. This kit uses a resistor network to create a reference point for the bypass input. In this case, the UPS output neutral *must* be bonded to the UPS ground. See Figure 5 above.

If the building service is corner-grounded delta or an impedance-grounded wye, the UPS requires the Series 600T Isolated Neutral Kit. This kit uses control isolation transformers to create a reference point. For this application, the UPS output neutral *must not* be bonded to the UPS ground.

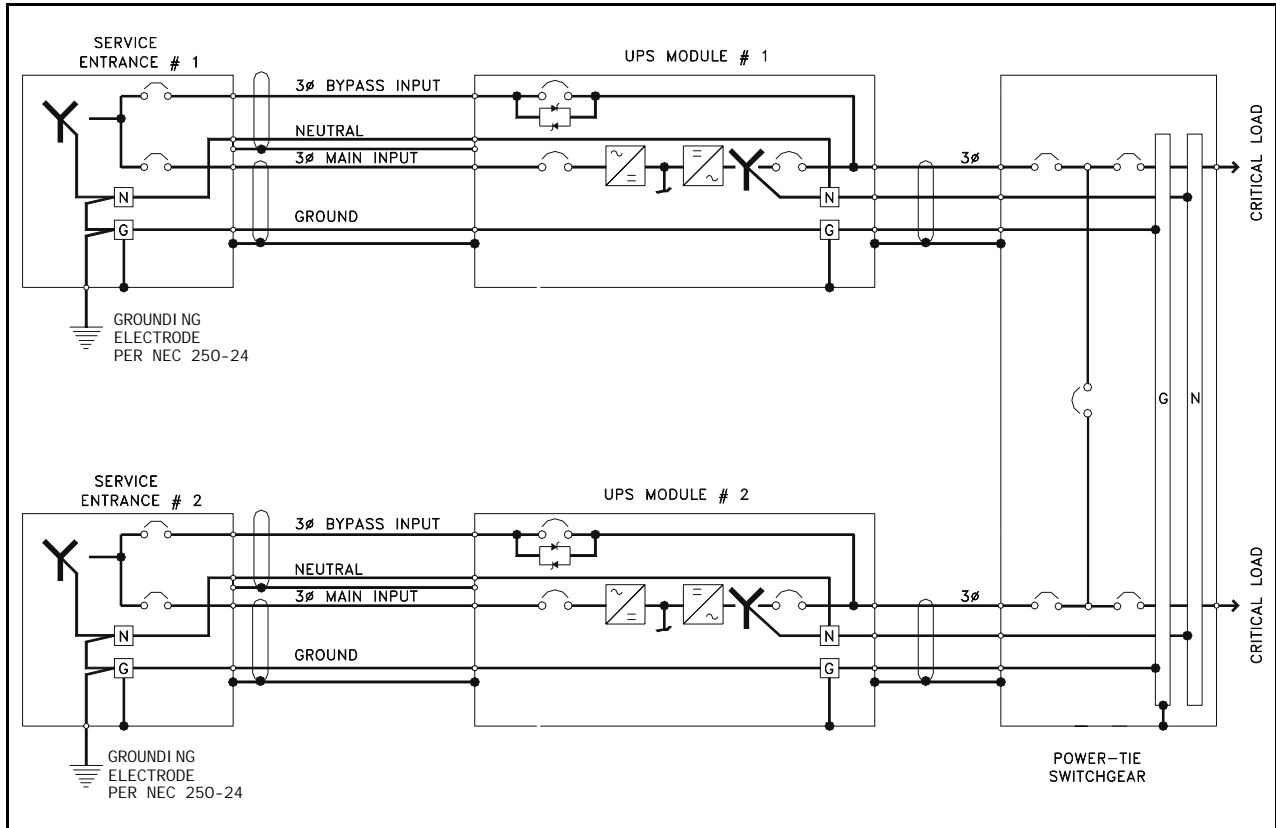

Figure 6. Preferred Grounding Configuration, Power-Tie™ Systems

## 7.6. Preferred Grounding Configuration, 480 or 600 VAC Input and Output, with Power-Tie™ Switchgear

Single Module Systems can be used with Power-Tie switchgear to provide dual critical load busses. The Power-Tie switchgear permits transferring critical loads from one critical bus to the other so that one UPS module and associated breakers can be de-energized for maintenance. Certain configurations of Power-Tie equipment also permit the operator to continuously parallel the output of the UPS modules.

In tied systems, each UPS module must have its neutral solidly connected to its own building service neutral and to the Power-Tie switchgear neutral. See Figure 6 above.

### NOTE

***It is essential to run a neutral connection between the tie switchgear and both UPS modules as shown in the illustration above.***

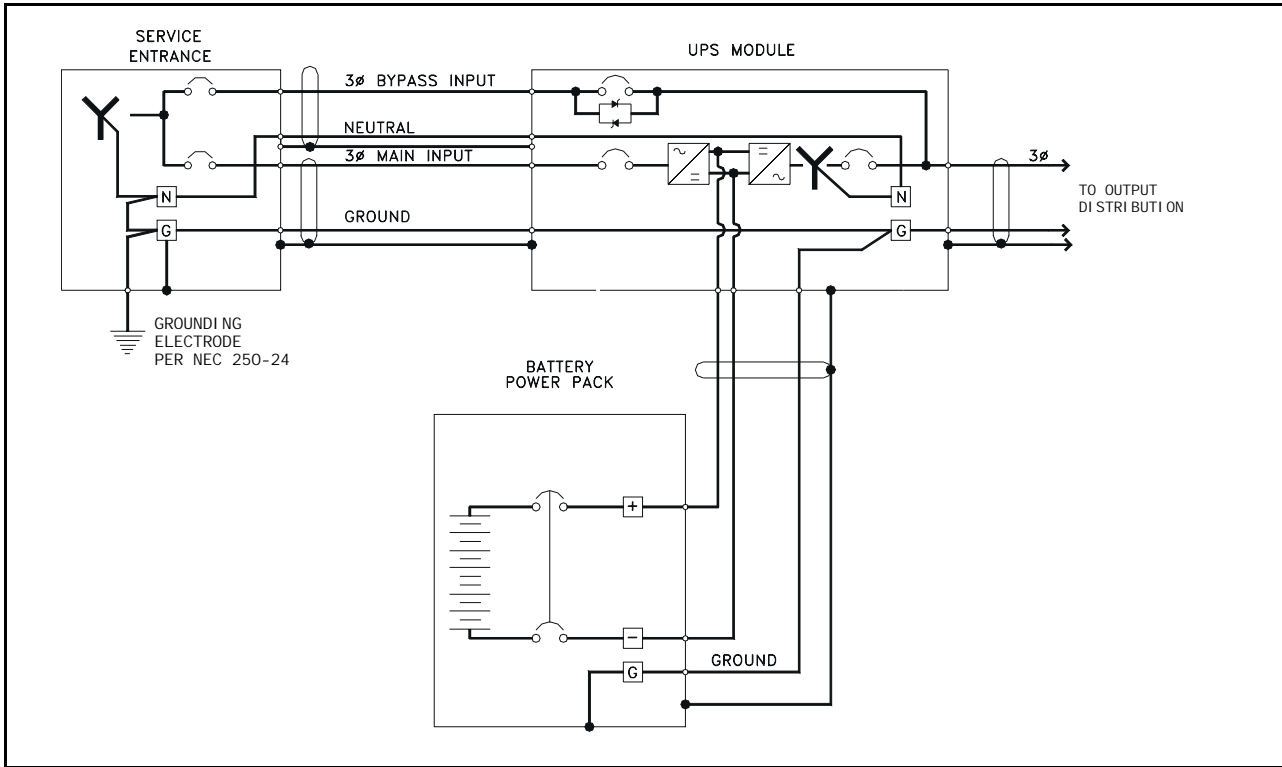

Figure 7. Preferred Battery Cabinet Grounding Configuration

### 7.7. Preferred Grounding Configuration, Battery Systems

Large, open-rack battery systems are normally either locally grounded or left ungrounded, depending on local code requirements.

Battery cabinet systems, on the other hand, should be grounded to the UPS ground bus bar. Figure 7 above illustrates how a simple one-cabinet system would be grounded. For systems with multiple cabinets, the same configuration would apply. However, for simplicity the installer can connect all the battery cabinet grounds together and run a single ground conductor (in the same conduit as the phase conductors) to the UPS ground.

## 8. WIRING CONSIDERATIONS

### 8.1. Power Wiring

Refer to Site Planning Data (Appendix A) and the installation drawings. Determine AC currents for your system based on kVA, kW, voltage, and options. Also refer to equipment nameplate for the model number, rating, and voltage. For wire termination data, refer to Tables 1-3.

1. Power wiring -- rectifier input, bypass input, UPS output, and battery cables -- must be run in individual, separate conduit or cable tray. Refer to the Outline and Terminal Details drawings (Figures 11-13 and 35-39) for location of the various power connections within the UPS.

---

#### CAUTION

---

##### **Power and control wiring must be separated!**

2. Observe local, state and national electrical codes. Verify utility power and its overcurrent protection rating will accommodate the UPS input rating, including battery recharging.
3. A safety ground wire must be run from building ground to ground point in the UPS Module Cabinet, the Battery Cabinet and the Power-Tie™ switchgear cabinet. See Sections 7.1 through 7.7. The grounding conductor shall comply with the following conditions of installation:
  - a. The insulated grounding conductor must be sized in accordance with the NEC and local codes. It must be green (with or without yellow stripes) and be installed as part of the branch circuit that supplies the unit or system.
  - b. The grounding conductor described above is to be grounded to earth at the service equipment or, if supplied by a separately derived system, at the supply transformer or motor-generator set in accordance with the instructions in Section 7 of this Manual.
  - c. The attachment-plug receptacles in the vicinity of the unit or system are all to be of a grounding type, and the grounding conductors serving these receptacles are to be

connected to earth ground at the service equipment.

4. Observe clockwise phase rotation of all power wiring. Phase A leads Phase B leads Phase C. A qualified electrician should check the phase rotation.
5. Power cables must be rated for less than 2 volts line drop at maximum rated system current.
6. Use 75°C copper wire. Select wire size based on the ampacities in Table 310-16 and associated notes of the National Electrical Code (NFPA 70) reprinted on page 24 of this manual.

---

#### CAUTION

---

**The weight of power cables must be adequately supported to avoid stress on bus bars and lugs. The following restraining method is recommended to both to support cable weight and control cable movement during external fault conditions: Wrap line cables together at 6 inches and 12 inches from the terminals with 5 wraps of 3/8 inch nylon rope or equivalent (tensile strength of 2000 pounds). Support remainder of cable with 5 wraps every 6 inches or 1 wrap every 1 inch.**

7. If site equipment includes a backup generator and automatic transfer switch(es), consult the manufacturers of those devices for information on sizing and interfacing to the UPS system.
8. The installing contractor can remove the access plates from the top left or top right sides of the UPS in order to cut entry holes for conduit. For units with bottom-entry cable access, there is a separate (third) access plate in the base of the unit, under the cable access wireway.

---

#### CAUTION

---

**After cutting holes in the access plates, be certain that no foreign matter (metal shavings, sawdust, insulation or wire fragments, etc.) remains inside the UPS. Likewise be certain to block any "extra" holes in the plates through which foreign matter could later enter the UPS.**

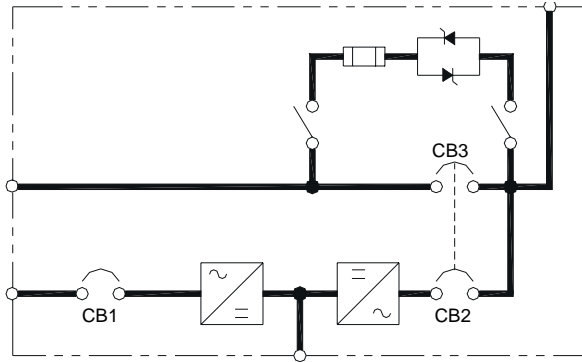

**Standard SMS, with 208/208, 480/480 or 600/600 VAC input/output.**

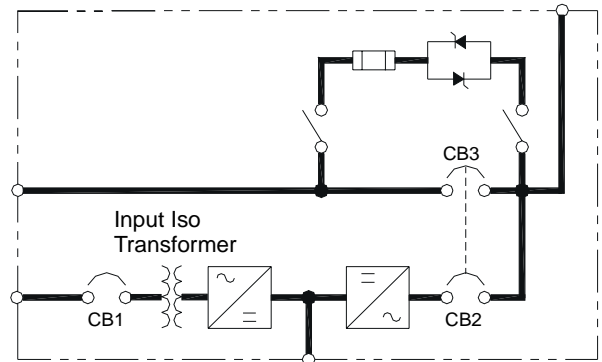

**SMS with input isolation transformer and 208/208, 480/480 or 600/600 VAC input/output.**

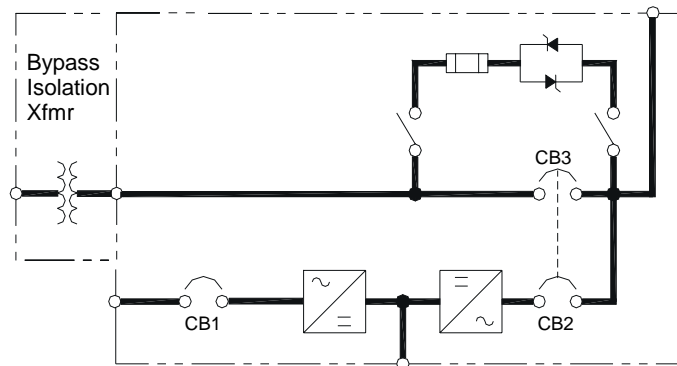

**600/208 VAC module with external bypass isolation transformer.**

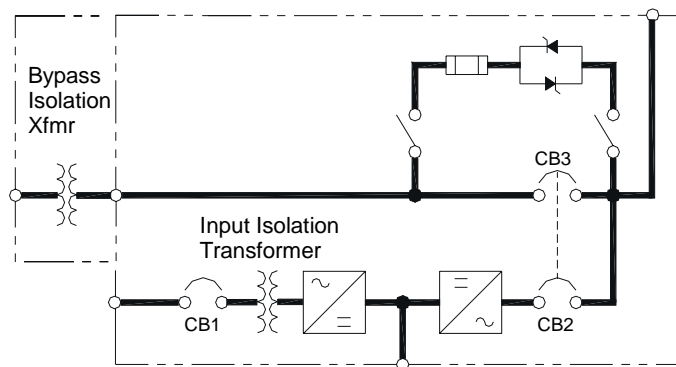

**480/208 or 600/208 VAC module with both internal input isolation transformer and external bypass isolation transformer.**

*Figure 8. Typical One-Line Diagrams for SMS with Standard Dual Input*

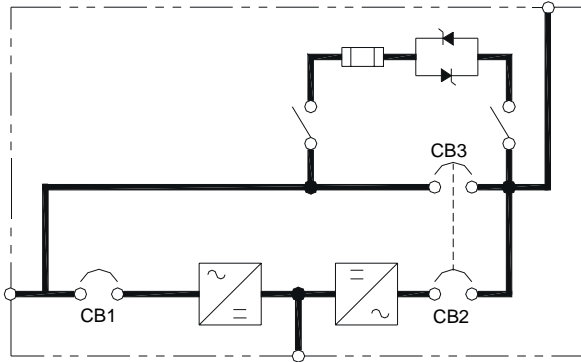

**Standard single-input SMS with 208/208, 480/480 or 600/600 VAC input/output.**

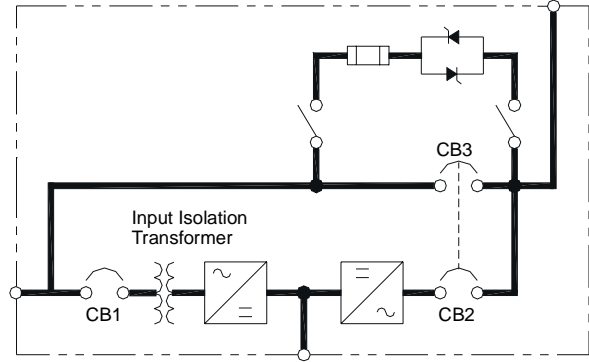

**Single-input SMS with input isolation transformer and 208/208, 480/480 or 600/600 VAC input/output.**

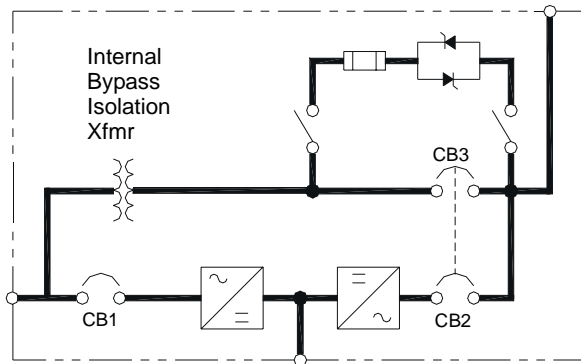

**480/208 VAC single-input SMS with bypass isolation transformer. Single-input modules are not available with both bypass and input isolation transformers.**

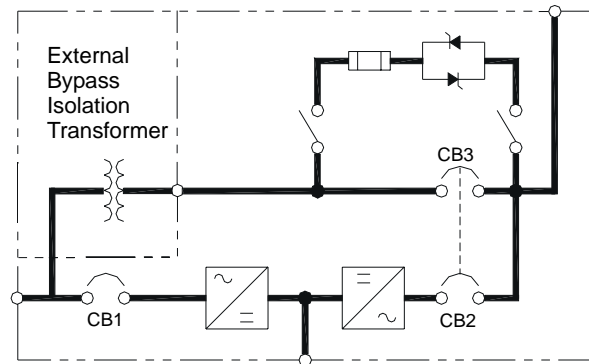

**600/208 VAC single-input SMS with bypass isolation transformer. Single-input modules are not available with both bypass and input isolation transformers.**

*Figure 9. Typical One-Line Diagrams of SMS with optional single input.*

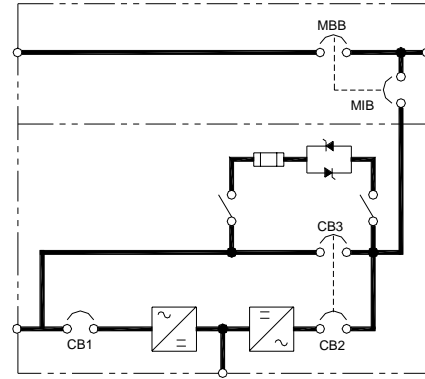
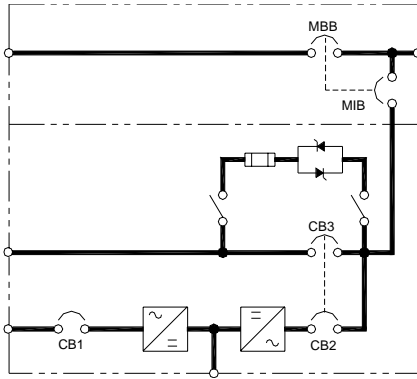

**2-breaker Maintenance Bypass Cabinets for standard (left) and single-input (right) modules.**

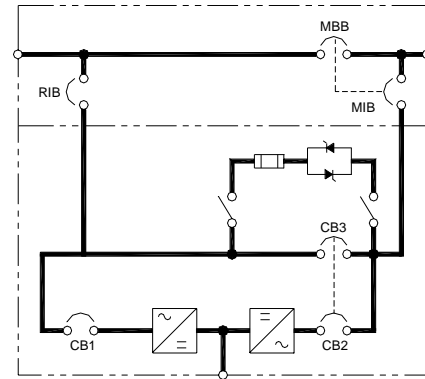
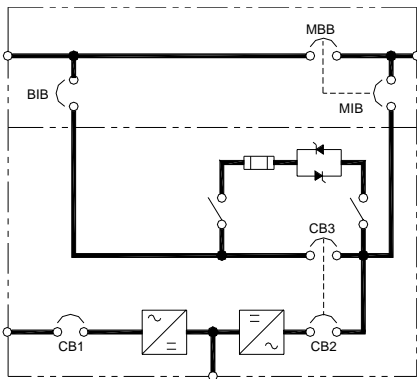

**3-breaker Maintenance Bypass Cabinets for standard (left) and single-input (right) modules.**

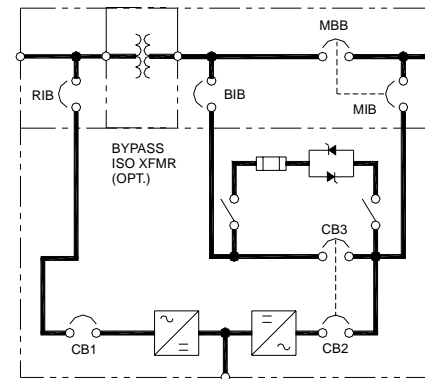
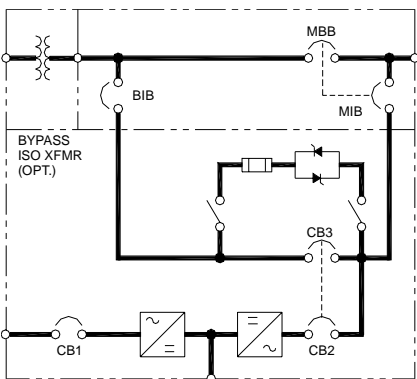

**3-breaker and 4-breaker Maintenance Bypass Cabinets for step-down-voltage applications.**

*Figure 10. Typical One-Line Diagrams of SMS with optional Maintenance Bypass Cabinets*

**Abbreviations for Circuit Breakers**

BIB	Bypass Isolation Breaker
MBB	Maintenance Bypass Breaker
MIB	Maintenance Isolation Breaker
RIB	Rectifier Input Breaker



## 8.2. Control Wiring

Control wiring must be stranded and tinned and run in individual separate steel conduit. Control wiring must be separated from power wiring. In addition, each control wiring cable group should be run in a separate conduit to minimize control signal interference.

If your system has any installed options, special wire lists will be included in your Submittal Drawing Package. Contact your Liebert Sales Representative for assistance if the Submittal drawings have been lost or misplaced.

All control cable groups are connected to different Interface Modules (IFMs) inside the UPS. Figure 29 shows the typical location of each IFM inside the UPS. The position of a particular IFM may be different for your UPS, depending upon the model and the installed options.

---

### NOTE

*The UPS control and communication wiring are considered Class 2 circuits by NEC standards. However, NEC Class 1 wiring methods are required for these circuits to ensure proper operation of the UPS.*

## 8.3. Battery Wiring

Power wiring to the Battery Cabinet connects positive, negative, and ground power cables from the Battery Cabinet to the associated UPS. Connection of the UPS to the Battery Cabinet serves to both charge and discharge the batteries (when needed). The battery disconnect (circuit breaker) requires a control cable. Liebert Battery Cabinets include power and control cables to join multiple cabinets together into a system. Additional (field-supplied) power or control wiring might be necessary to connect the battery cabinet system to the UPS. Refer to Figures 16-17.

---

### DANGER

**A BATTERY INTERCELL CONNECTION ON EACH TIER IS DISCONNECTED FOR SAFETY DURING SHIPMENT. DO NOT COMPLETE THESE CONNECTIONS. THE LIEBERT GLOBAL SERVICES REPRESENTATIVE WILL COMPLETE THESE CONNECTIONS AS PART OF START-UP. AN IMPROPERLY INSTALLED UNIT CAN RESULT IN INJURY TO PERSONNEL OR DAMAGE TO EQUIPMENT.**

---

### CAUTION

**Be sure polarity is correct when wiring the Battery Cabinet to the connected equipment (positive to positive; negative to negative). If polarity is not correct, fuse failures or equipment damage can result.**

---

### CAUTION

**DC power cables should be installed in conduit with conductors in matched pairs (positive and negative).**

---

### NOTE

*Inspection of the battery installation is a service that can be provided by Liebert. A Battery Specialist can perform a detailed inspection of the entire battery system to ensure it meets current IEEE standards. This inspection service is recommended because batteries are a critical part of the UPS system.*

## 9. WIRING CONNECTIONS

### 9.1 Warnings

---

#### DANGER

---

**VERIFY THAT ALL INCOMING HIGH AND LOW VOLTAGE POWER CIRCUITS ARE DE-ENERGIZED AND LOCKED OUT BEFORE INSTALLING CABLES OR MAKING ELECTRICAL CONNECTIONS.**

**ALL POWER CONNECTIONS MUST BE COMPLETED BY A LICENSED ELECTRICIAN EXPERIENCED IN WIRING UPS EQUIPMENT, AND IN ACCORDANCE WITH ALL APPLICABLE NATIONAL AND LOCAL ELECTRICAL CODES.**

**IMPROPER WIRING MAY CAUSE DAMAGE TO THE UPS OR INJURY TO PERSONNEL.**

---

#### CAUTION

---

All shielded cables, non-shielded cables, non-shielded control wires, non-shielded battery breaker control wires, and non-shielded remote control wires must be housed in individual, separate, steel conduits. Placing multiple cables in the same conduit with other control or power wiring may cause system failure.

### 9.2 Specific Connections

Refer to the drawings in this manual and any other drawings provided by Liebert for this installation. Make all of the following connections:

- a. AC power cables from input power source circuit breaker to UPS Module Input. Observe phase rotation.

---

#### CAUTION

---

**See Section 7 of this Manual for an explanation of proper grounding techniques.**

- b. AC power cables from bypass power source circuit breaker to UPS Module Bypass input. Observe phase rotation.
- c. AC power cables from UPS Module Output to critical load. Observe phase rotation.

---

#### NOTE

---

***If your installation includes a Maintenance Bypass Cabinet, Switchboard or Panelboard, some (or all) power cables will be terminated in these cabinet(s). Make sure all required wiring between UPS module and the optional cabinet(s) is completed. Observe phase rotation.***

- d. The UPS Module Output Neutral must be connected to one common point and solidly grounded per requirements of the National Electrical Code. See Section 7.

---

#### CAUTION

---

**UPS bypass and output neutral must be connected to only one common point in the UPS. This neutral line must be grounded at the source.**

- e. For Battery Cabinets:

DC power cables and ground from Battery Cabinet to UPS Module, and between Battery Cabinets. Observe polarity. DC power cables should be installed in matched pairs (positive and negative).

---

**NOTE**

---

***DC power and battery circuit breaker control cables are provided with the Liebert brand Battery Cabinets. Power cables are sized for interconnecting Battery Cabinets. Battery Cabinets specified for bolting up to the UPS are shipped with power cables to connect the Battery Cabinet system to the UPS Module. Field-supplied cabling must be provided to connect “stand-alone” Battery Cabinets to the UPS Module.***

---

**DANGER**

---

**DO NOT MAKE ANY CONNECTIONS BETWEEN BATTERY TIERS IN THE BATTERY CABINET. THESE CONNECTIONS WILL BE MADE BY THE LIEBERT GLOBAL SERVICES REPRESENTATIVE DURING START-UP.**

**f.** For remote battery:

DC power cables (and ground) from battery to Module Battery Disconnect, and then to UPS Module DC bus. Observe polarity. DC power cables should be installed in conduit with conductors in matched pairs (positive and negative).

- g.** Module Battery Disconnect control wiring to UPS Module (and between Battery Cabinets, if applicable).
- h.** Control wiring to Remote Monitor Panel, if used. Selected alarm messages are also available for customer use through a set of contacts on a separate terminal board. Wiring must be run in individual separate steel conduit.
- i.** Emergency Power Off control wiring must be run in separate steel conduit.
- j.** Communications wiring for site monitoring or for modem must be run in separate steel conduit.
- k.** Power and control connections required for the Maintenance Bypass.
- l.** Any additional special wiring required at the customer site.

## 10. WIRING INSPECTION

1. Verify all power connections are tightened per the torque specifications in Table 2. Verify all control wire terminations are tight.
2. Verify all power wires and connections have proper spacing between exposed surfaces, phase-to-phase and phase-to-ground.
3. Verify that all control wires are run in steel conduit, separate from all power wiring.

<b>Table 1</b>	
<b>Power Wiring Terminals - Factory Supplied</b>	
<b>UPS MODULE</b>	<b>CONNECTION TYPE</b>
65 & 80 kVA	Bypass input wiring is top-entry, to busbars on top of the circuit breaker. Rectifier input wiring is top-entry, directly to lugs on top of the input circuit breaker. DC link and critical bus output connections are top entry, to frame-mounted lugs. A bottom-entry access plate is standard, to enable the installer to pull AC cables and control wiring through the module to the connections on top.
100-225 kVA	For "SpaceSaver" modules in the 48" frame, rectifier and bypass input wiring is top-entry, directly to lugs on top of their respective circuit breakers. DC link and critical bus output connection are top entry, to frame-mounted lugs. Standard modules with top-and-bottom entry have access plates and a wireway on the right side of the modules. All power connections are to bus bars in the wireway.

Use 75°C copper wire. Select wire size based on the ampacities in Table 310-16 and associated notes of the National Electrical Code (NFPA 70).

Use commercially available solderless lugs for the wire size required for your application. Refer to Table 3. Connect wire to the lug using tool and procedure specified by the lug manufacturer.

<b>Table 2</b>				
<b>Torque Specifications</b>				
<b>NUT AND BOLT COMBINATIONS</b>				
<b>BOLT SHAFT SIZE</b>	<b>GRADE 2 STANDARD</b>		<b>ELECTRICAL CONNECTIONS with Belleville Washers</b>	
	<b>Lb - in</b>	<b>N-m</b>	<b>Lb-in</b>	<b>N-m</b>
1/4	53	6.0	46	5.2
5/16	107	12	60	6.8
3/8	192	22	95	11
1/2	428	22	256	29

<b>CIRCUIT BREAKERS WITH COMPRESSION LUGS (For Power Wiring)</b>			<b>TERMINAL BLOCK COMPRESSION LUGS (For Control Wiring)</b>		
<b>WIRE SIZE OR RANGE</b>	<b>Lb-in</b>	<b>N-m</b>	<b>AWG WIRE SIZE OR RANGE</b>	<b>Lb-in</b>	<b>N-m</b>
#6 - #4	100	11	#22 -#14	3.5 to 5.3	0.4 to 0.6
#3 - #1	125	14			
1/0 - 2/0	150	17			
3/0 - 200 MCM	200	23			
250 - 400 MCM	250	28			
500 - 700 MCM	300	34			

**Table 3  
Field-Supplied Lugs**

<b>ONE-HOLE LUGS</b>						
	<b>T &amp; B LUG STYLE</b>	<b>WIRE SIZE</b>	<b>BOLT SIZE (INCHES)</b>	<b>TONGUE WIDTH (IN.)</b>	<b>T &amp; B P/N</b>	<b>LIEBERT P/N</b>
1	STAK-ON	1/0 AWG	3/8	0.88	J973	12-714255-56
2		2/0 AWG	3/8	1.00	K973	12-714255-66
3		3/0 AWG	3/8	1.10	L973	12-714255-76
4		4/0 AWG	3/8	1.20	M973	12-714255-86
5	COLOR-KEYED ALUMINUM/ COPPER	1/0 AWG	3/8	0.93	60130	
6		2/0 AWG	3/8	0.97	60136	
7		3/0 AWG	3/8	1.06	60142	
8	COLOR-KEYED COPPER CABLE LONG BARREL	1/0 AWG	3/8	0.75	54909BE	
9		2/0 AWG	3/8	0.81	54910BE	
10		3/0 AWG	1/2	0.94	54965BE	
11		4/0 AWG	1/2	1.03	54970BE	
12		250MCM	1/2	1.09	54913BE	
13	NARROW-TONGUE	350MCM	1/2	1.09	55165	
14	COPPER CABLE	500MCM	1/2	1.20	55171	

NOTES:

1. Manufacturer: Thomas & Betts (T & B). (800) 862-8324

**Table 310-16. Allowable Ampacities of Insulated Conductors  
Rated 0-2000 Volts, 60° to 90°C (140° to 194°F)  
Not More Than Three Conductors in Raceway or Cable or  
Earth (Directly Buried), Based on Ambient Temperature of 30° (86°F)**

Size	Temperature Rating of Conductor. See Table 310-13.						Size
	60°C (140°F)	75°C (167°F)	90°C (194°F)	60°C (140°)	75°C (167°F)	90°C (194°F)	
AWG kcmil	TYPES TW= UF=	TYPES FEPW= RH, RHW= THHW= THW= THWN= XHHW= USE=, ZW=	TYPES TBS, SA, SIS, FEP= FEPB=, MI, RHH= RHW-2 THHN=, THHW= THW-2, THWN-2, USE-2, XHH, XHHW= XHHW-2, ZW-2	TYPES TW= UF=	TYPES RH=, RHW= THHW= THW= THWN= XHHW= USE=	TYPES TBS, SA, SIS, THHN= THHW= THW-2, THWN-2, RHH=, RHW-2, USE-2, XHH, XHHW= XHHW-2, ZW-2	AWG kcmil
	COPPER			ALUMINUM OR COPPER-CLAD ALUMINUM			
18	.....	.....	14	.....	.....	.....	.....
16	.....	.....	18	.....	.....	.....	.....
14*	20	20	25	.....	.....	.....	.....
12*	25	25	30	20	20	25	12*
10*	30	35	40	25	30	35	10*
8	40	50	55	30	40	45	8*
6	55	65	75	40	50	60	6
4	70	85	95	55	65	75	4
3	85	100	110	65	75	85	3
2	95	115	130	75	90	100	2
1	110	130	150	85	100	115	1
1/0	125	150	170	100	120	135	1/0
2/0	145	175	195	115	135	150	2/0
3/0	165	200	225	130	155	175	3/0
4/0	195	230	260	150	180	205	4/0
250	215	255	290	170	205	230	250
300	240	285	320	190	230	255	300
350	260	310	350	210	250	280	350
400	280	335	380	225	270	305	400
500	320	380	430	260	310	350	500
600	355	420	475	285	340	385	600
700	385	460	520	310	375	420	700
750	400	475	535	320	385	435	750
800	410	490	555	330	395	450	800
900	435	520	585	355	425	480	900
1000	455	545	615	375	445	500	1000
1250	495	590	665	405	485	545	1250
1500	520	625	705	435	520	585	1500
1750	545	650	735	455	545	615	1750
2000	560	665	750	470	560	630	2000
CORRECTION FACTORS							
Ambient Temp °C	For ambient temperatures other than 30°C (86°F), multiply the allowable ampacities shown above by the appropriate factor shown below.						Ambient Temp °F
21-25	1.08	1.05	1.04	1.08	1.05	1.04	70-77
26-30	1.00	1.00	1.00	1.00	1.00	1.00	78-86
31-35	.91	.94	.96	.91	.94	.96	87-95
36-40	.82	.88	.91	.82	.88	.91	96-104
41-45	.71	.82	.87	.71	.82	.87	105-113
46-50	.58	.75	.82	.58	.75	.82	114-122
51-55	.41	.67	.76	.41	.67	.76	123-131
56-60	.....	.58	.71	.....	.58	.71	132-140
61-70	.....	.33	.58	.....	.33	.58	141-158
71-80	.....	.....	.41	.....	.....	.41	159-176

\*Unless otherwise specifically permitted in Section 240-3 of this Code, the overcurrent protection for conductor types marked with an asterisk (\*) shall not exceed 15 amperes for No. 14, 20 amperes for No. 12, and 30 amperes for No. 10 copper; or 15 amperes for No. 12 and 25 amperes for No. 10 aluminum and copper-clad aluminum after any correction factors for ambient temperature and number of conductors have been applied.

Reprinted with permission from NEC 1999, NFPA 70, the *National Electrical Code*, Copyright 1998, National Fire Protection Association, Quincy, MA 02269. This reprinted material is not the complete and official position of the National Fire Protection Association, on the referenced subject which is represented only by the standard in its entirety.

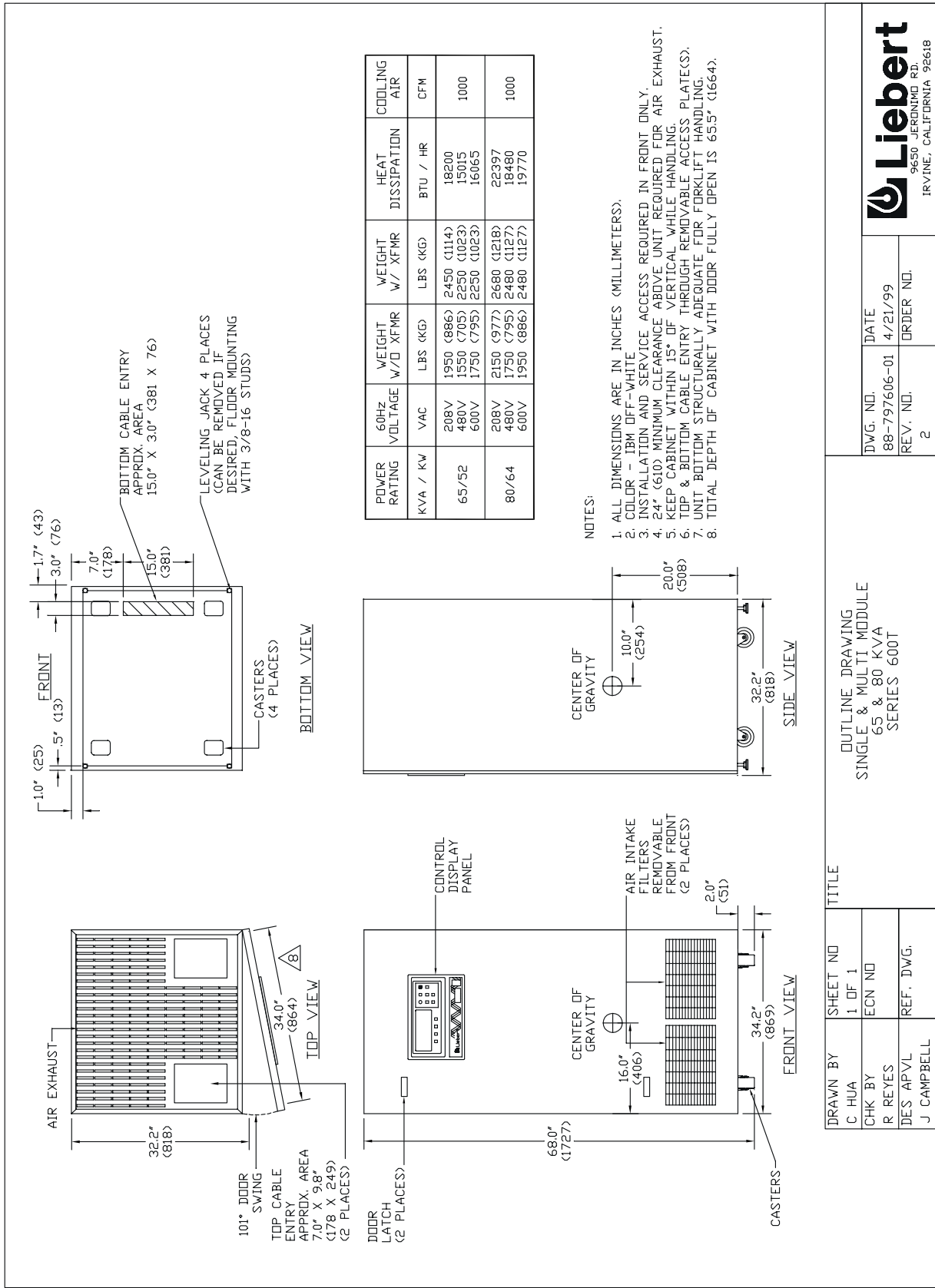

Figure 11. Outline Drawing Single and Multi Module 65 & 80 kVA

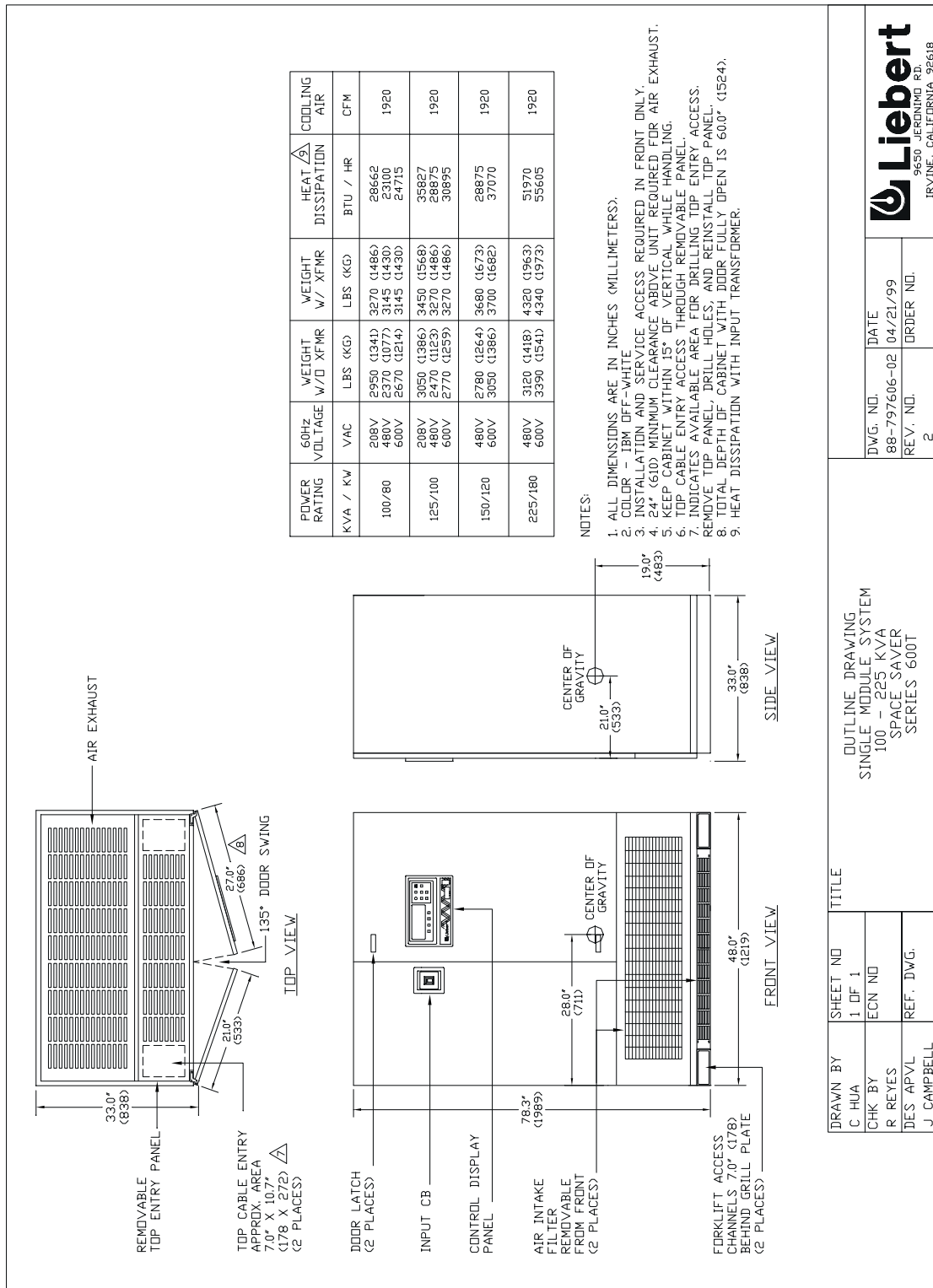

Figure 12. Outline Drawing, 100 through 225 kVA Module with SpaceSaver Top-Entry Configuration



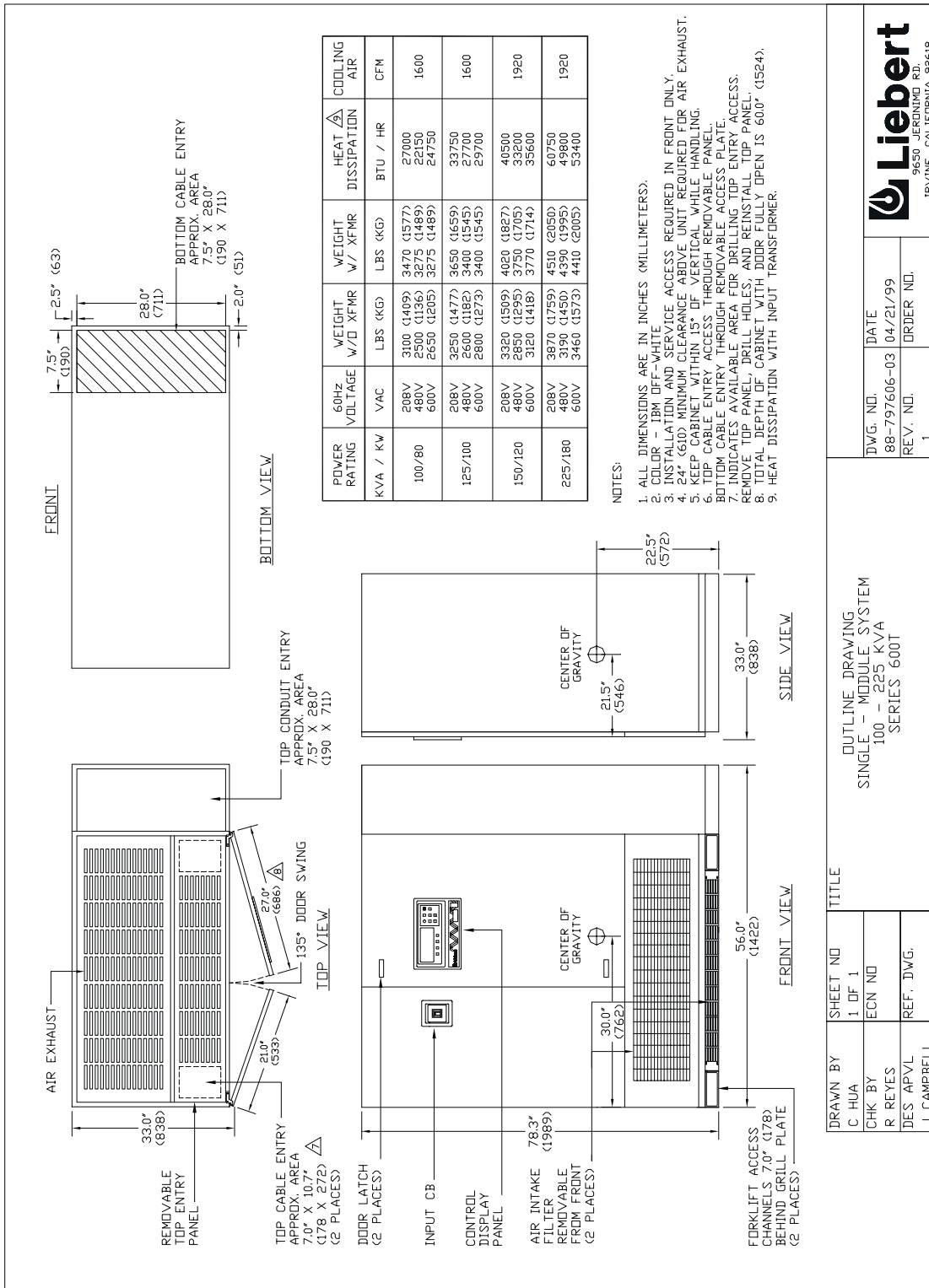

Figure 13. Outline Drawing, 100 through 225 kVA Module with Standard Top & Bottom Entry

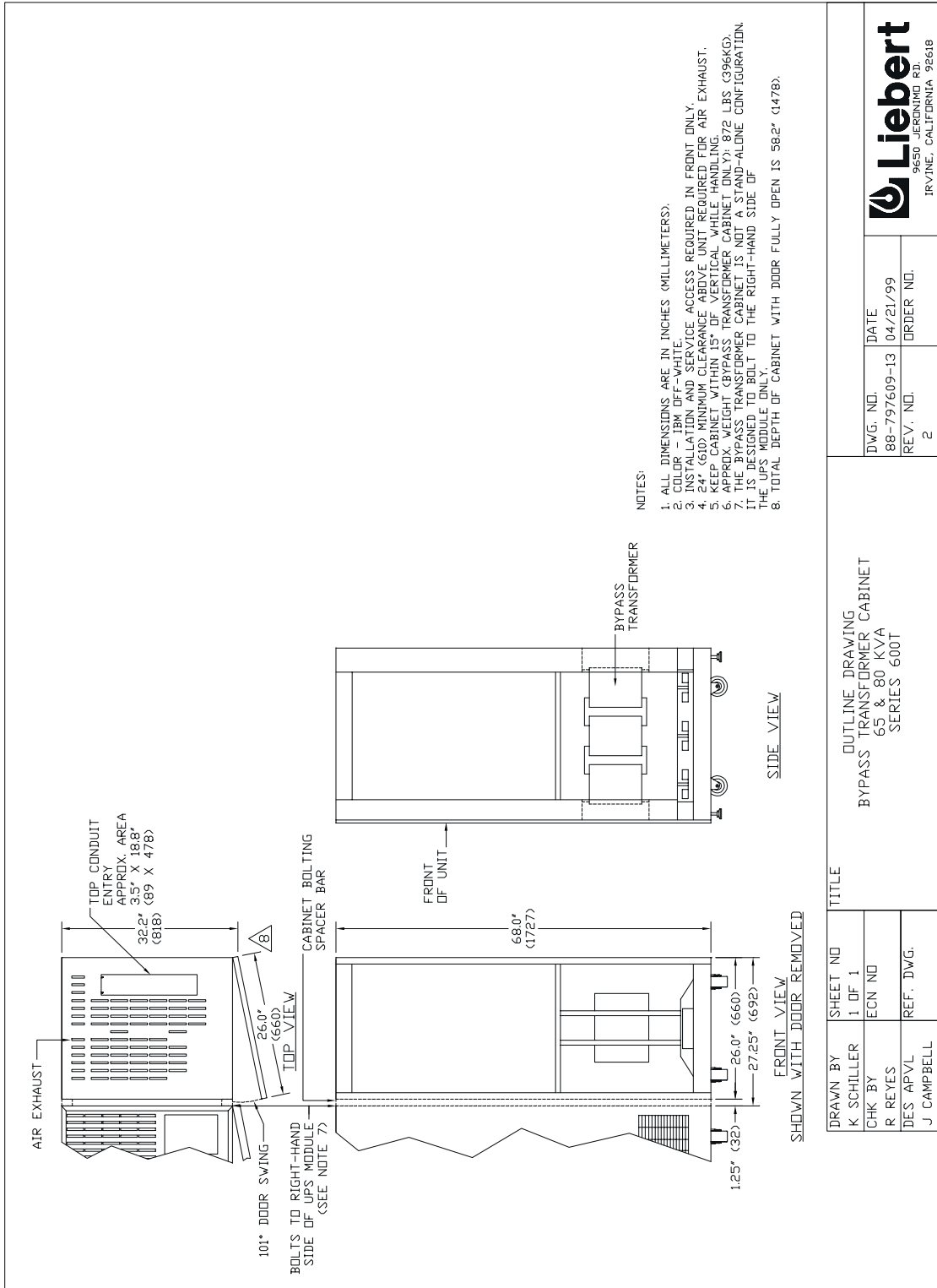

Figure 14. Bypass Transformer Cabinet, 65 & 80 kVA

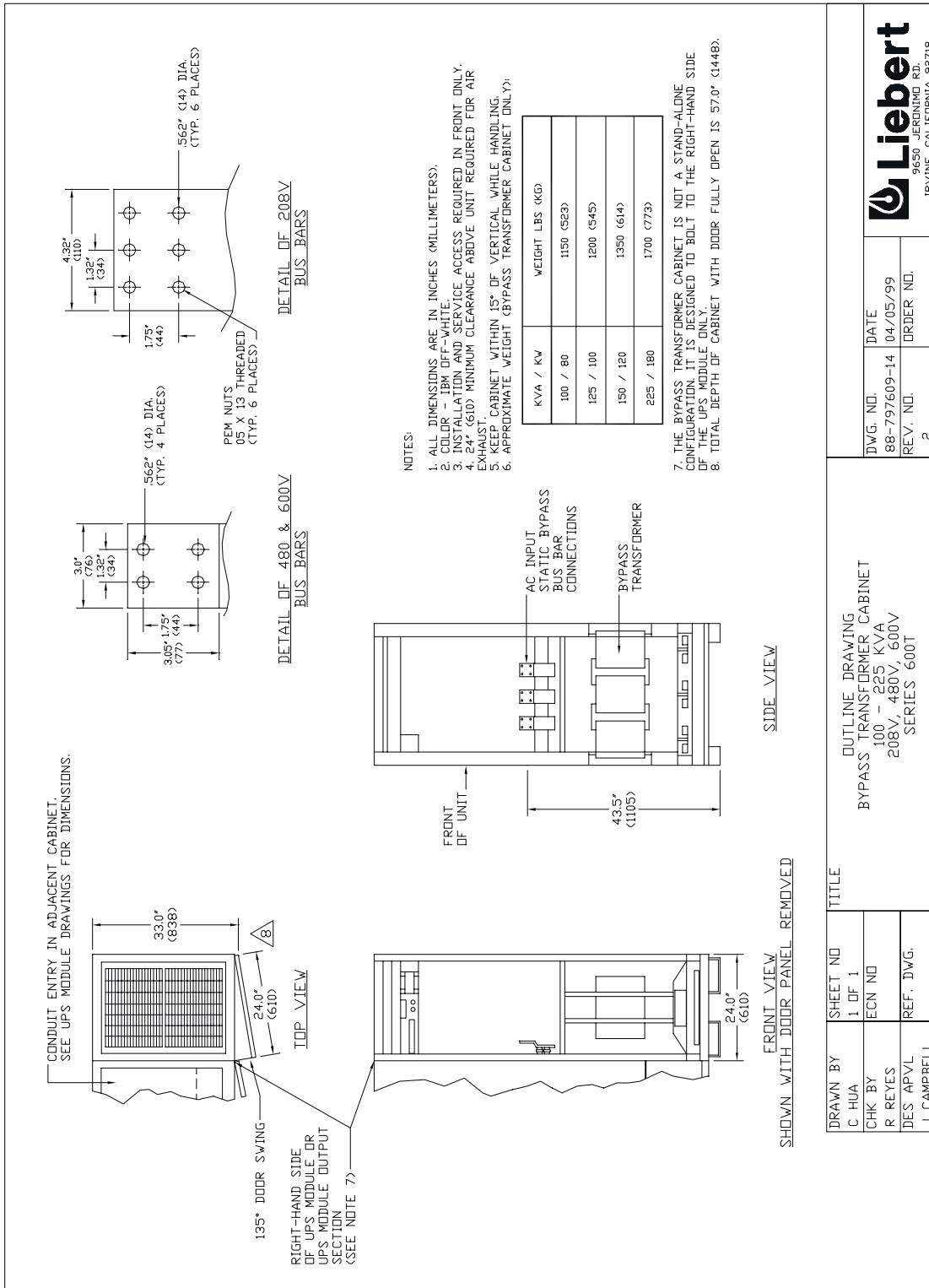

Figure 15. Bypass Transformer Cabinet, 100-225 kVA

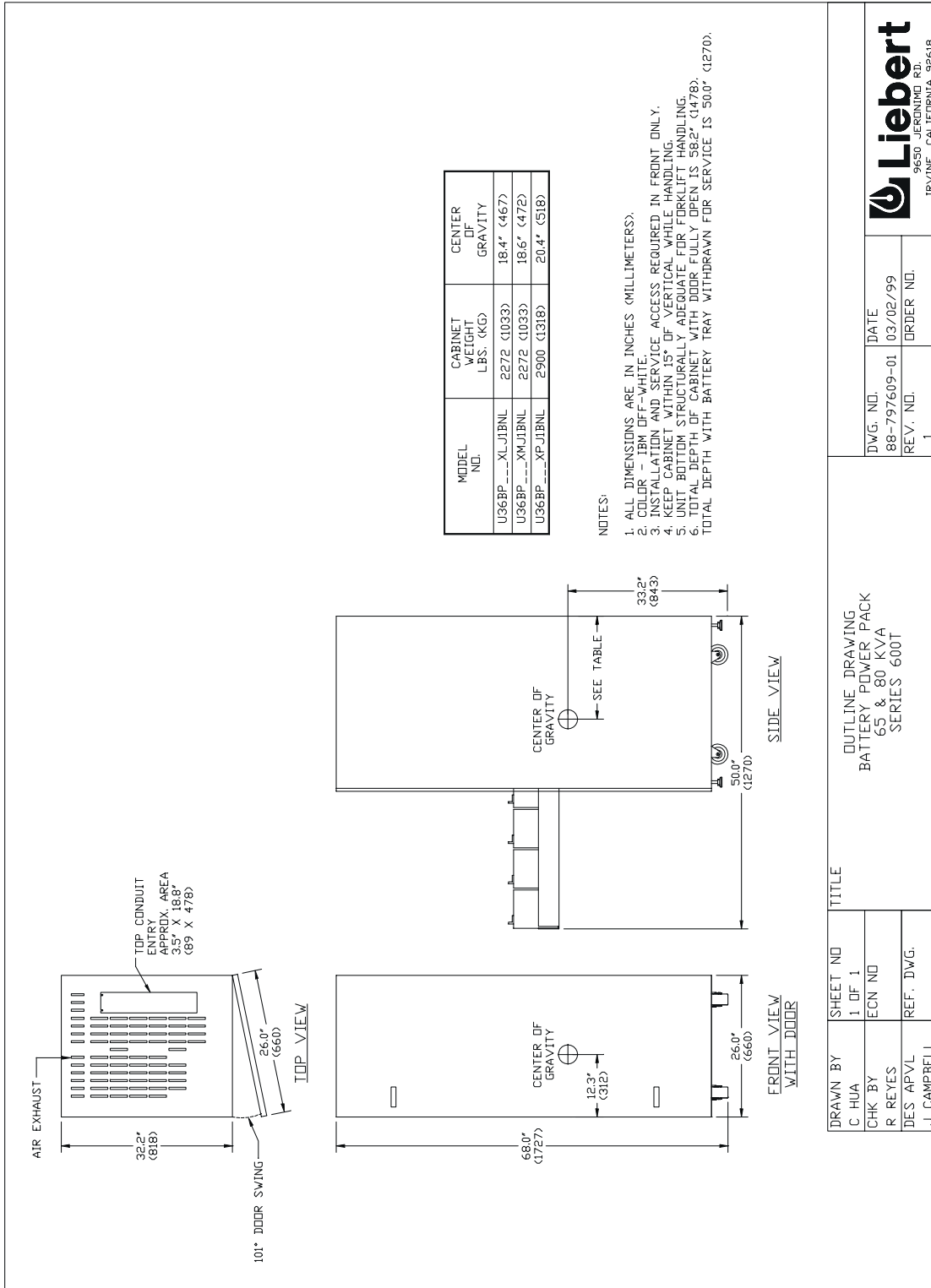

Figure 16. Battery Power Pack, 65 & 80 kVA

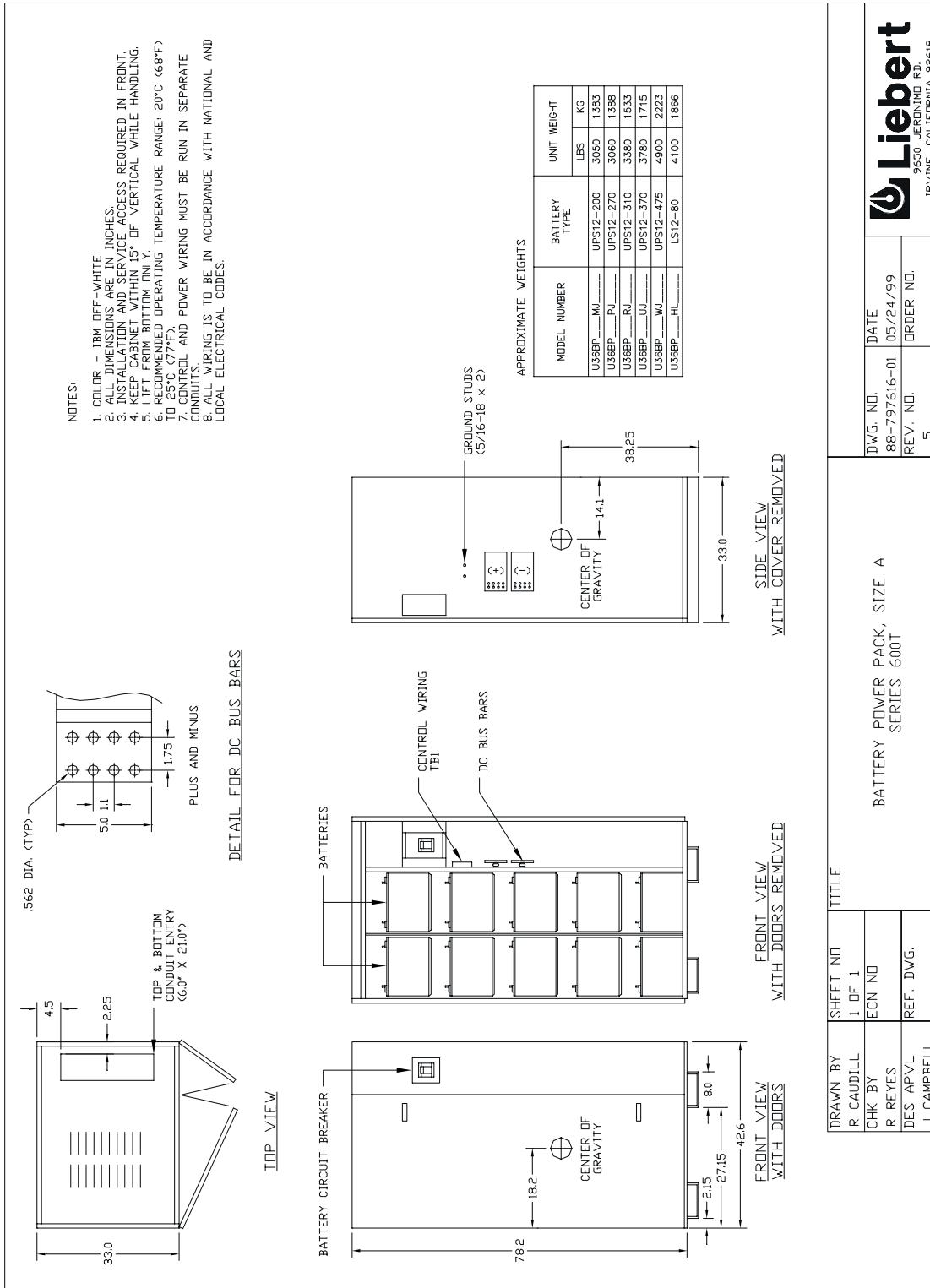

Figure 17. Battery Power Pack, Size A, 100-225 kVA

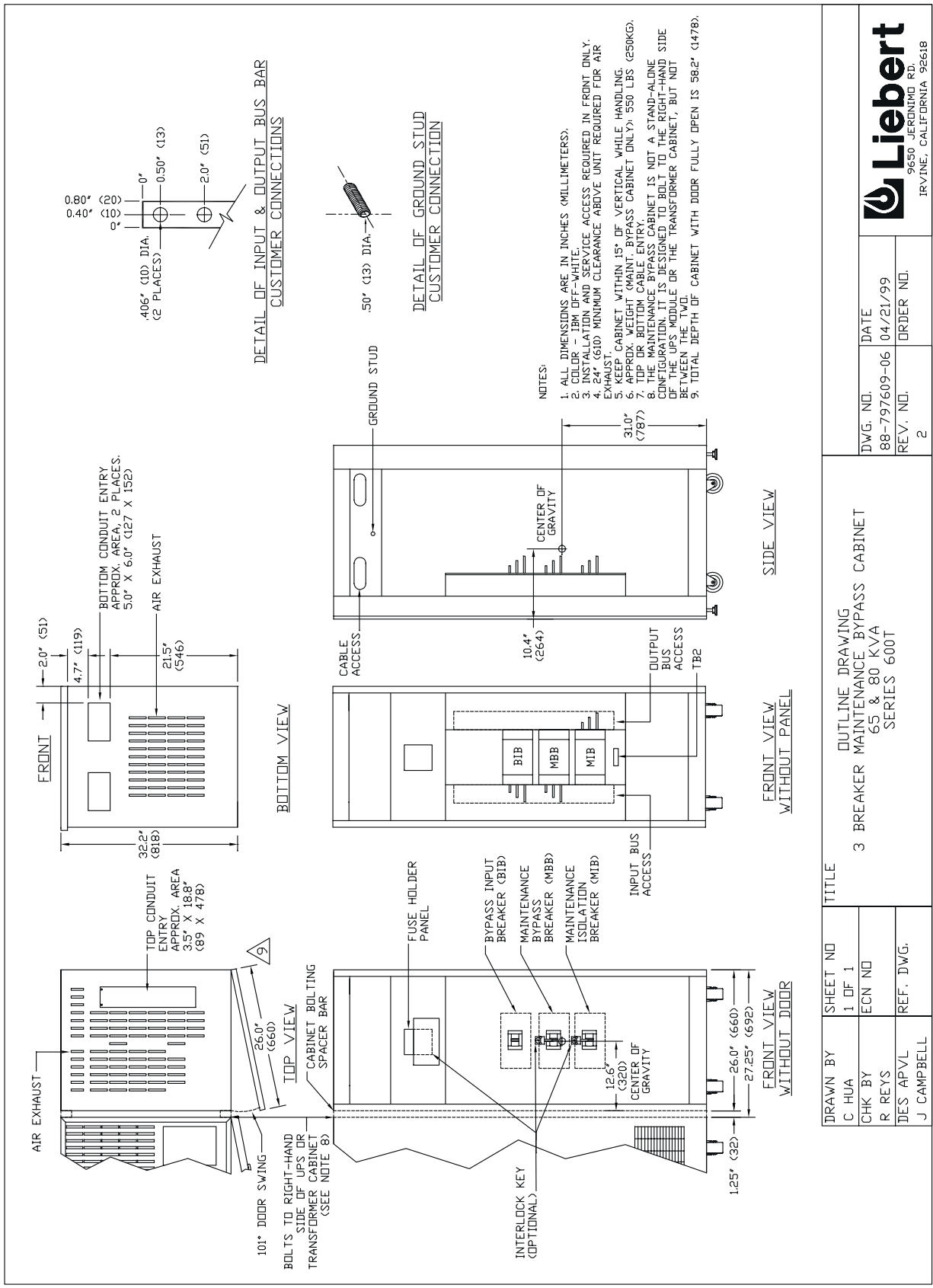

Figure 18. Outline Drawing, 3-Breaker MBC, 65 & 80 kVA



DWG. NO.	DATE
88-797609-06	04/21/99
REV. NO.	ORDER NO.
2	

FILE NAME: 88-797609-06-02.DWG

DRAWN BY	SHEET NO	TITLE
C HUA	1 OF 1	OUTLINE DRAWING
CHK BY	ECN NO	3 BREAKER MAINTENANCE BYPASS CABINET
R REYS		65 & 80 KVA
DES APVL	REF. DWG.	SERIES 600T
J CAMPBELL		

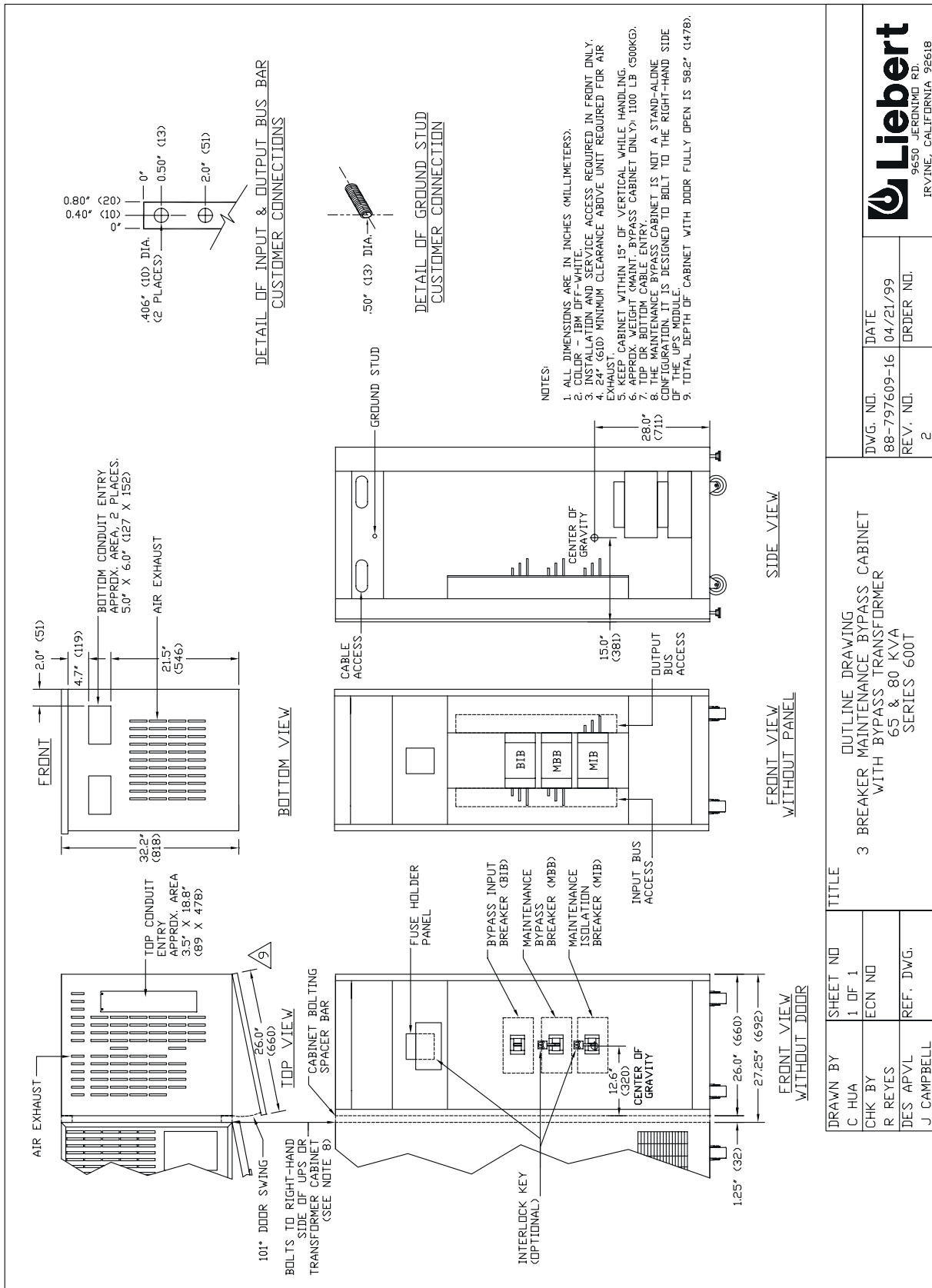

Figure 19. Outline Drawing, 3-Breaker MBC with Bypass Transformer, 65 & 80 kVA

DRAWN BY C HUA	SHEET NO 1 OF 1	TITLE 3 BREAKER MAINTENANCE BYPASS CABINET WITH BYPASS TRANSFORMER 65 & 80 KVA SERIES 600T	DWG. NO. 88-797609-16	DATE 04/21/99
CHK BY R REYES	ECN NO		REV. NO. 2	ORDER NO.
DES APVL J CAMPBELL	REF. DWG.		FILE NAME: 88-797609-16-Q2.DWG	



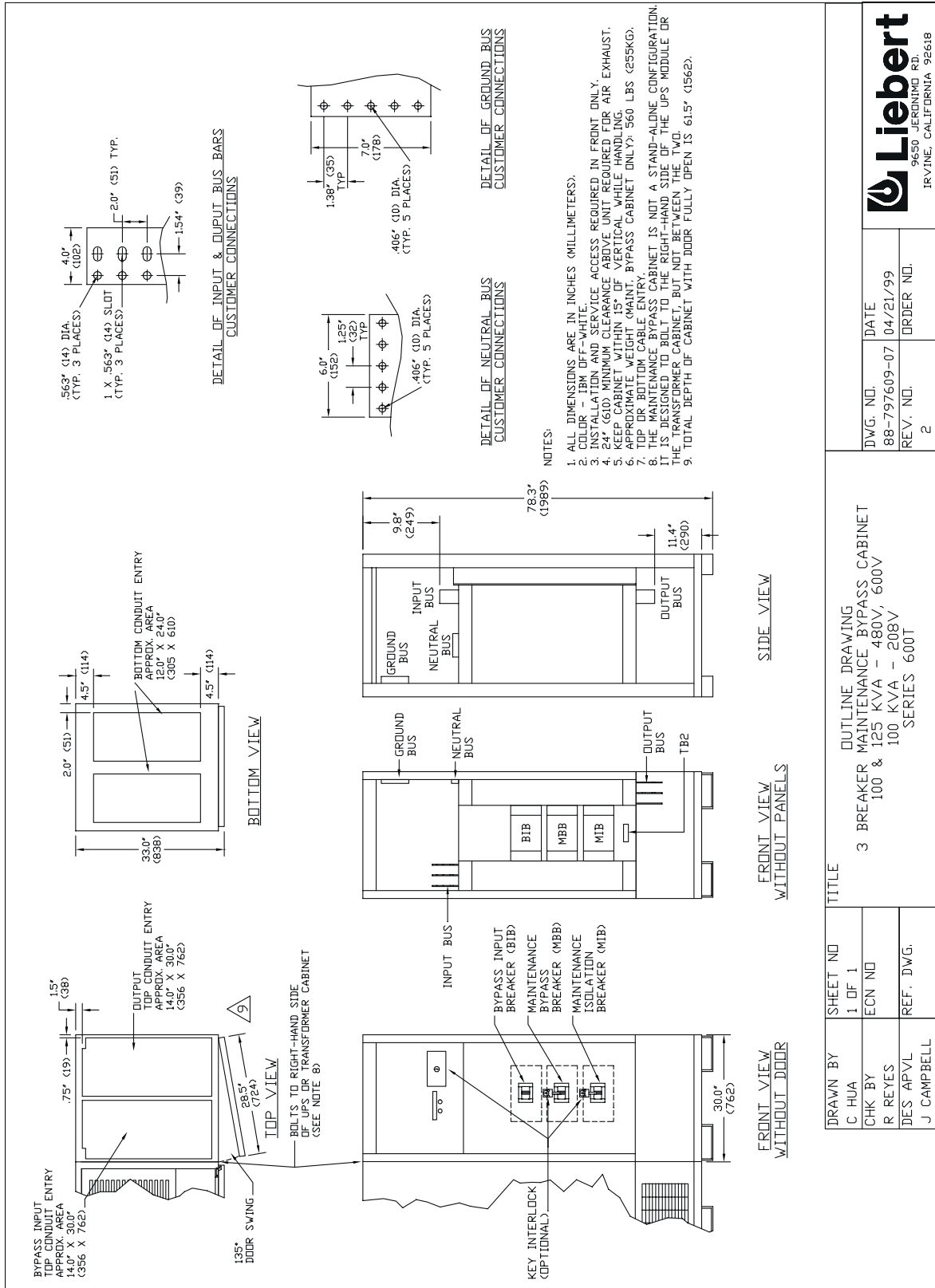

Figure 20. Outline Drawing, 3-Breaker MBC, 125-350 Amps

DRAWN BY C HUA		SHEET NO 1 OF 1		TITLE 3 BREAKER MAINTENANCE BYPASS CABINET 100 & 125 KVA - 480V, 600V 100 KVA - 208V SERIES 600T	
CHK BY R REYES		ECN NO		DWG. NO. 88-797609-07	
DES APVL J CAMPBELL		REF. DWG.		DATE 04/21/99	
				REV. NO. 2	
				ORDER NO.	
				FILE NAME: 88-797609-07-02.DWG	



9650 JERONIMO RD.  
IRVINE, CALIFORNIA 92618





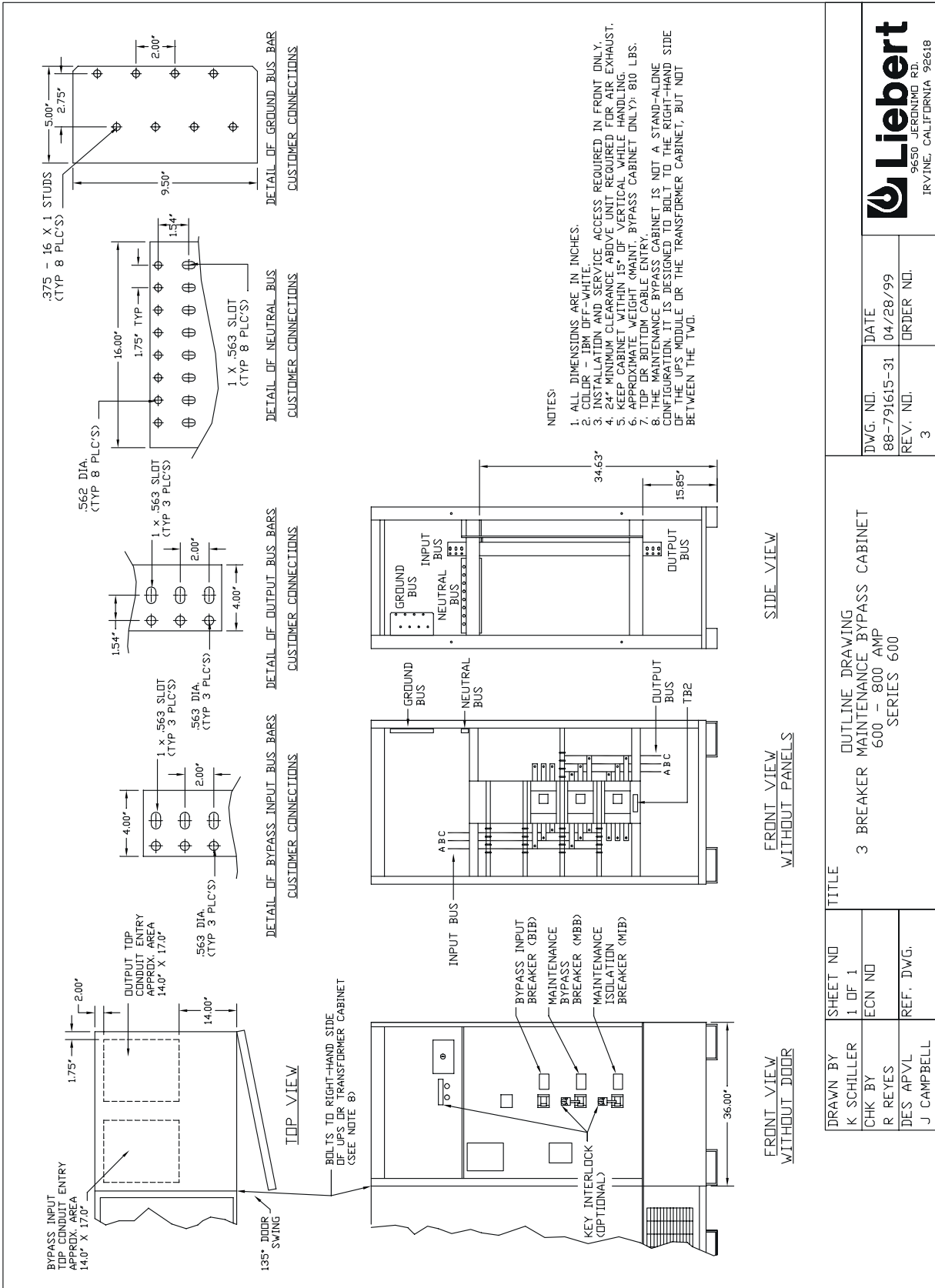

Figure 22. Outline Drawing, 3-Breaker MBC, 600-800 Amps

DRAWN BY K SCHILLER		SHEET NO 1 OF 1		TITLE 3 BREAKER MAINTENANCE BYPASS CABINET	
CHK BY R REYES		ECN NO		600 - 800 AMP SERIES 600	
DES APVL J CAMPBELL		REF. DWG.		DWG. NO. 88-791615-31	
				DATE 04/28/99	
				ORDER NO.	
				3	



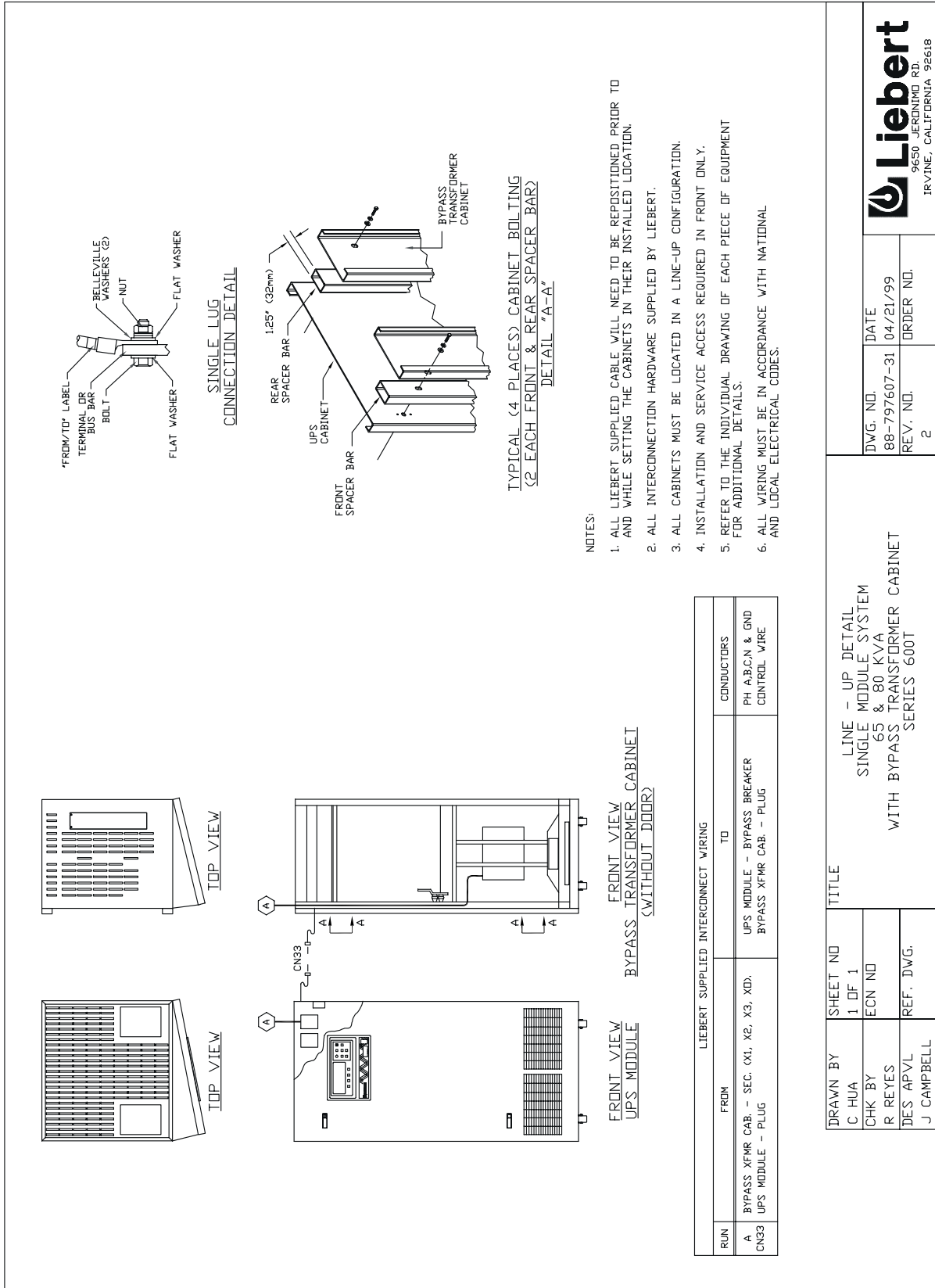

Figure 23. Line-up Detail, 65 & 80 kVA SMS with Bypass Transformer Cabinet

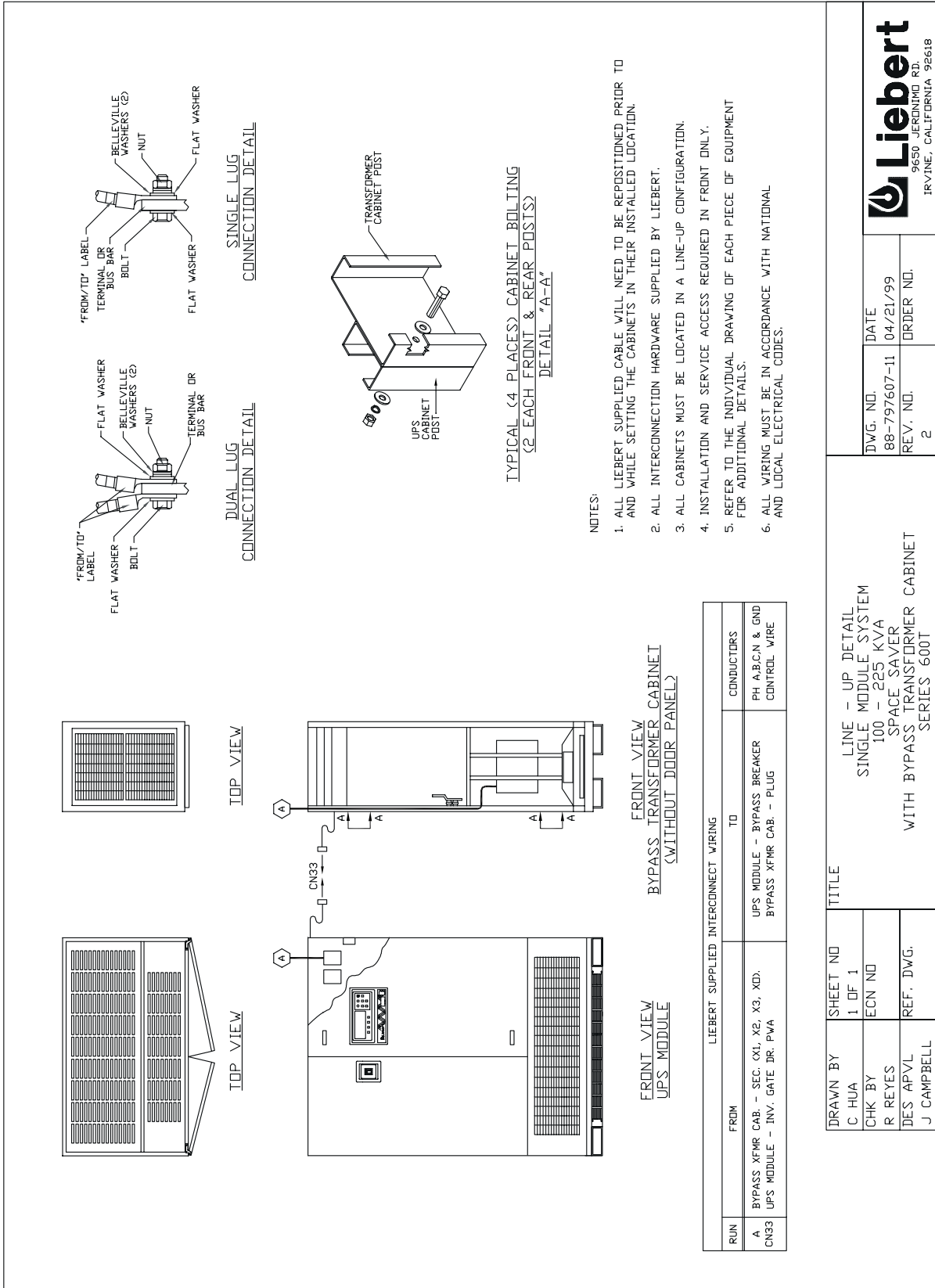

Figure 24. Line-up Detail, 100-225 kVA Space Saver with Bypass Transformer Cabinet



DWG. NO.	DATE
88-797607-11	04/21/99
REV. NO.	ORDER NO.
2	

FILE NAME: 88-797607-11-02.DWG

DRAWN BY	SHEET NO	TITLE
C HUA	1 OF 1	LINE - UP DETAIL
CHK BY	ECN NO	SINGLE MODULE SYSTEM
R REYES		100 - 225 KVA
DES APVL	REF. DWG.	SPACE SAVER
J CAMPBELL		WITH BYPASS TRANSFORMER CABINET
		SERIES 600T

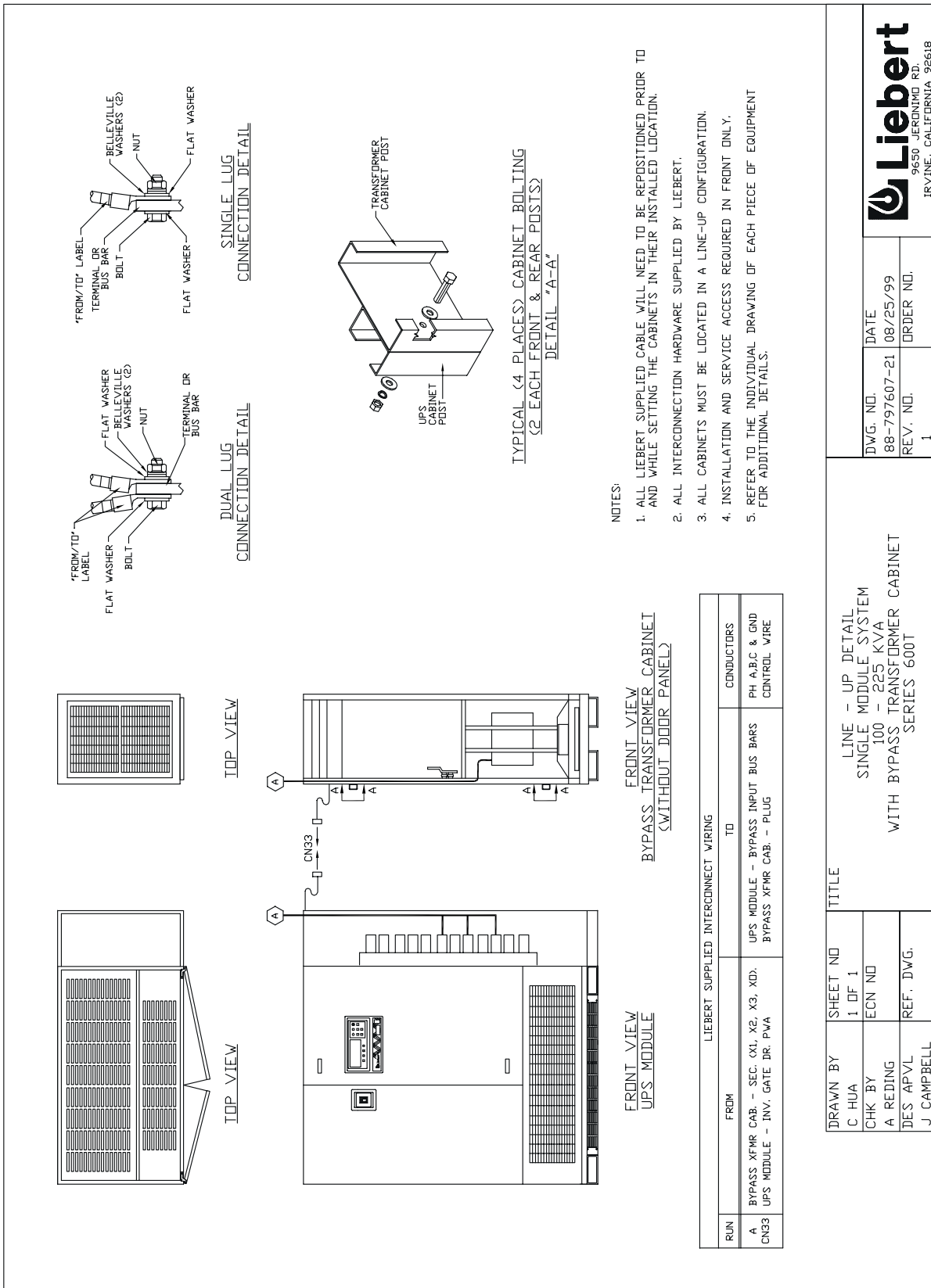

Figure 25. Line-up Detail, 100-225 kVA Standard SMS with Bypass Transformer Cabinet

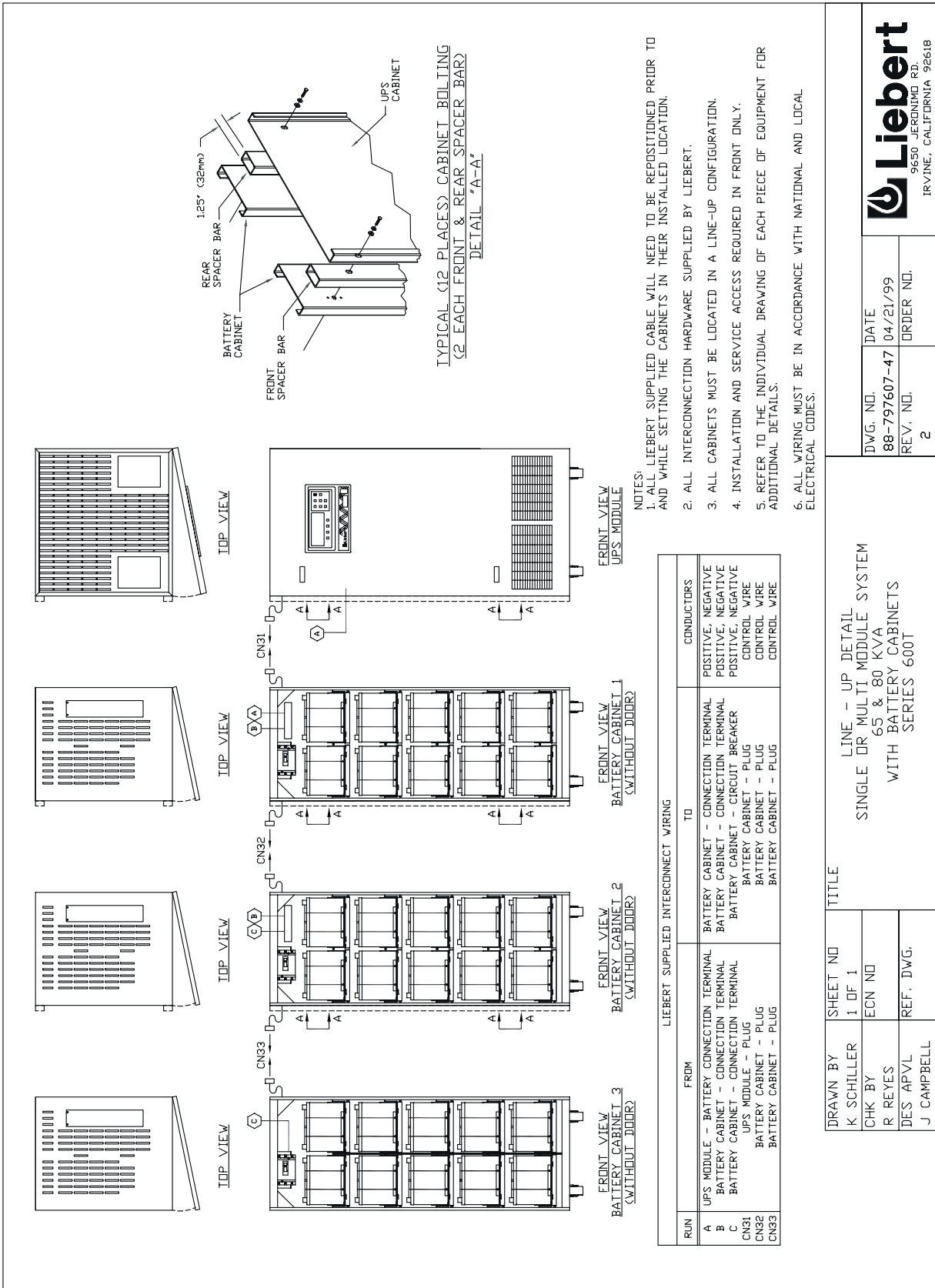

Figure 26. Line-up Detail, 65 & 80 kVA SMS with Battery Cabinets



IRVINE, CALIFORNIA 92618  
 9650 JERDIND RD.  
 ORDER NO.  
 04/21/99  
 DATE  
 88-797607-47  
 REV. NO.  
 2

FILE NAME: 88-797607-47-02.DWG

DRAWN BY K SCHILLER CHK BY R REYES DES APVL J CAMPBELL	SHEET NO 1 OF 1 ECN NO REF. DWG.
<b>TITLE</b> LINE - UP DETAIL SINGLE OR MULTI MODULE SYSTEM 65 & 80 KVA WITH BATTERY CABINETS SERIES 600T	

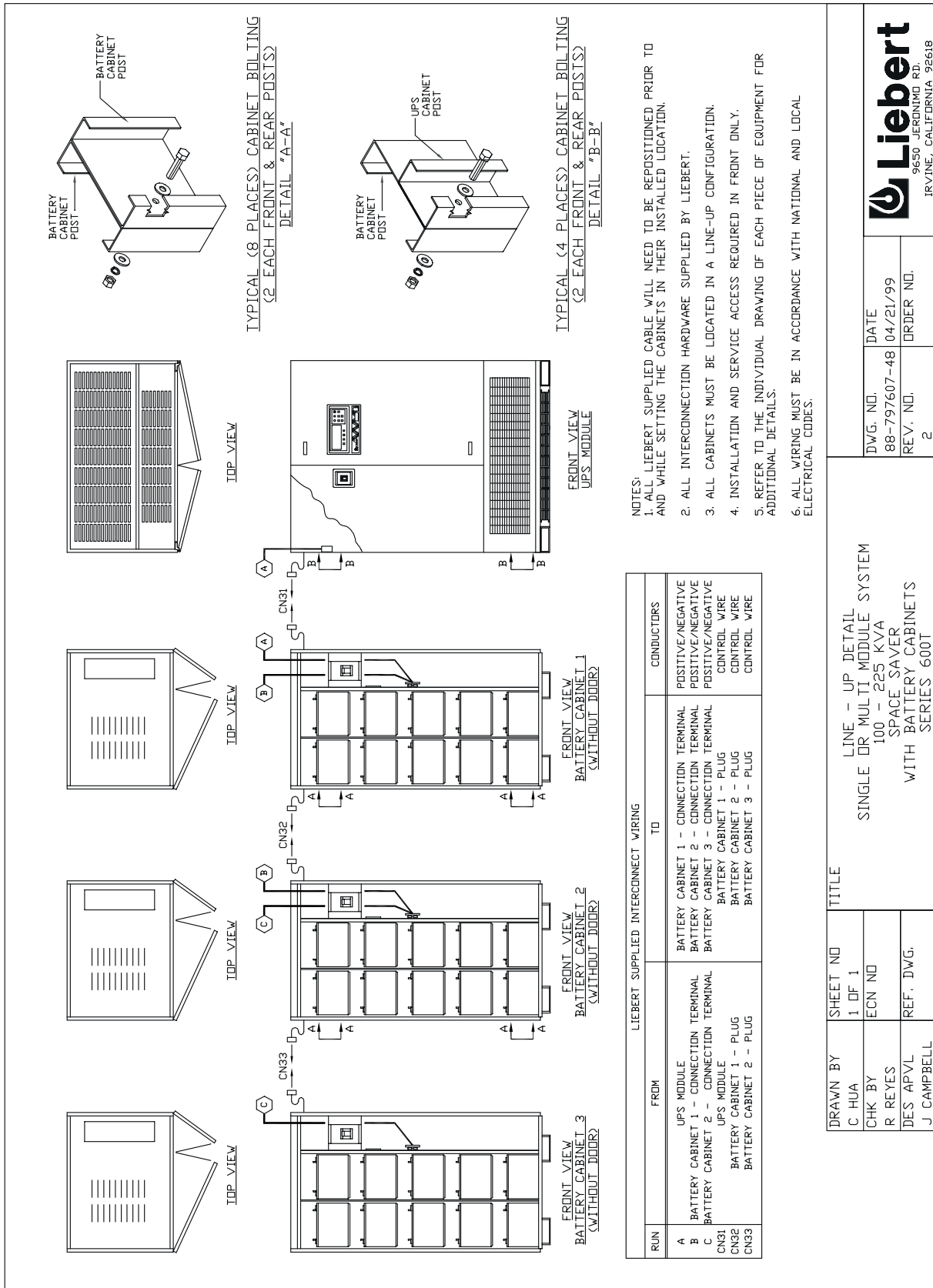

Figure 27. Line-up Detail, 100-225 kVA Space Saver with Battery Cabinets

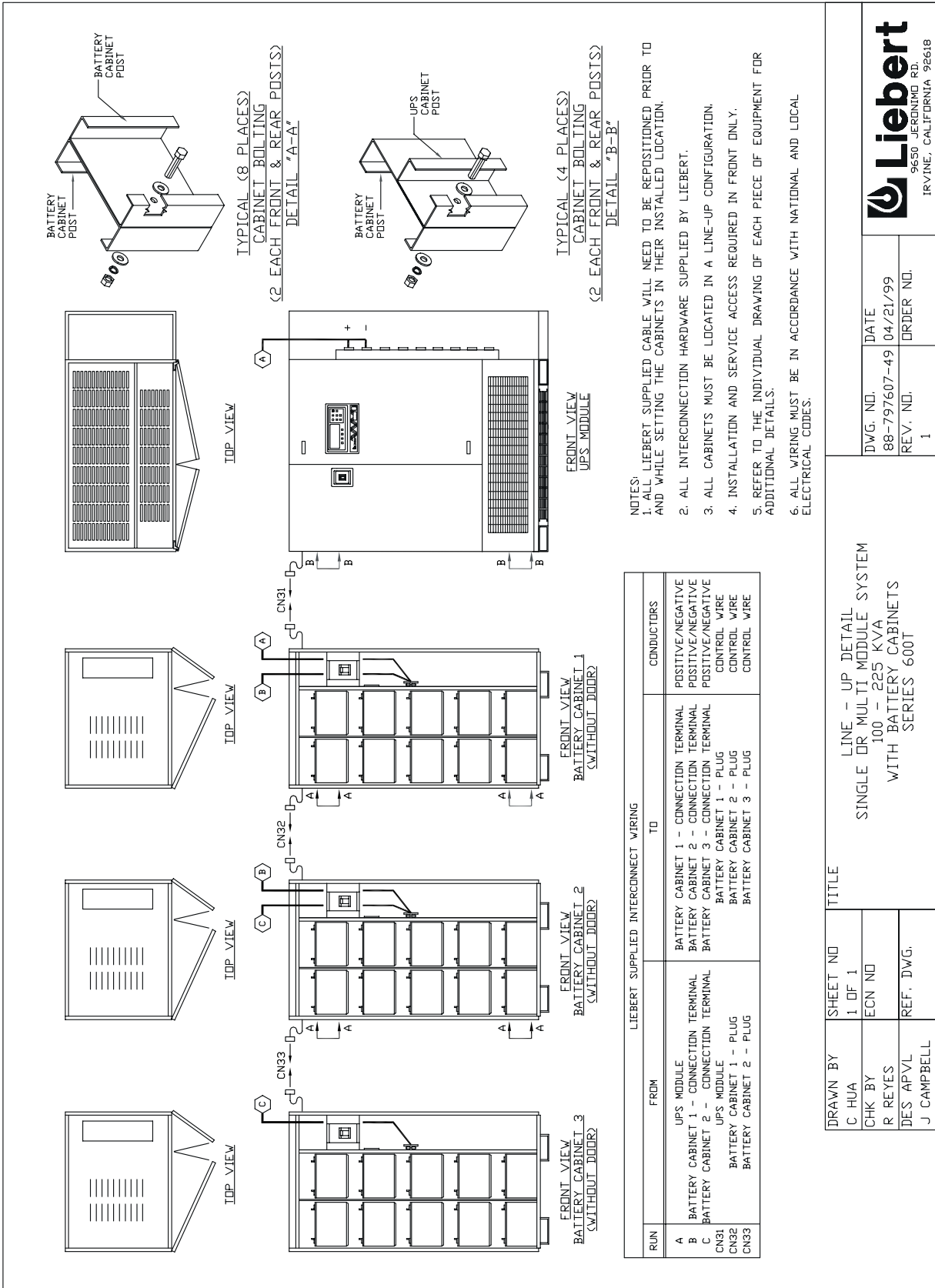

Figure 28. Line-up Detail, 100-225 kVA Standard SMS with Battery Cabinets



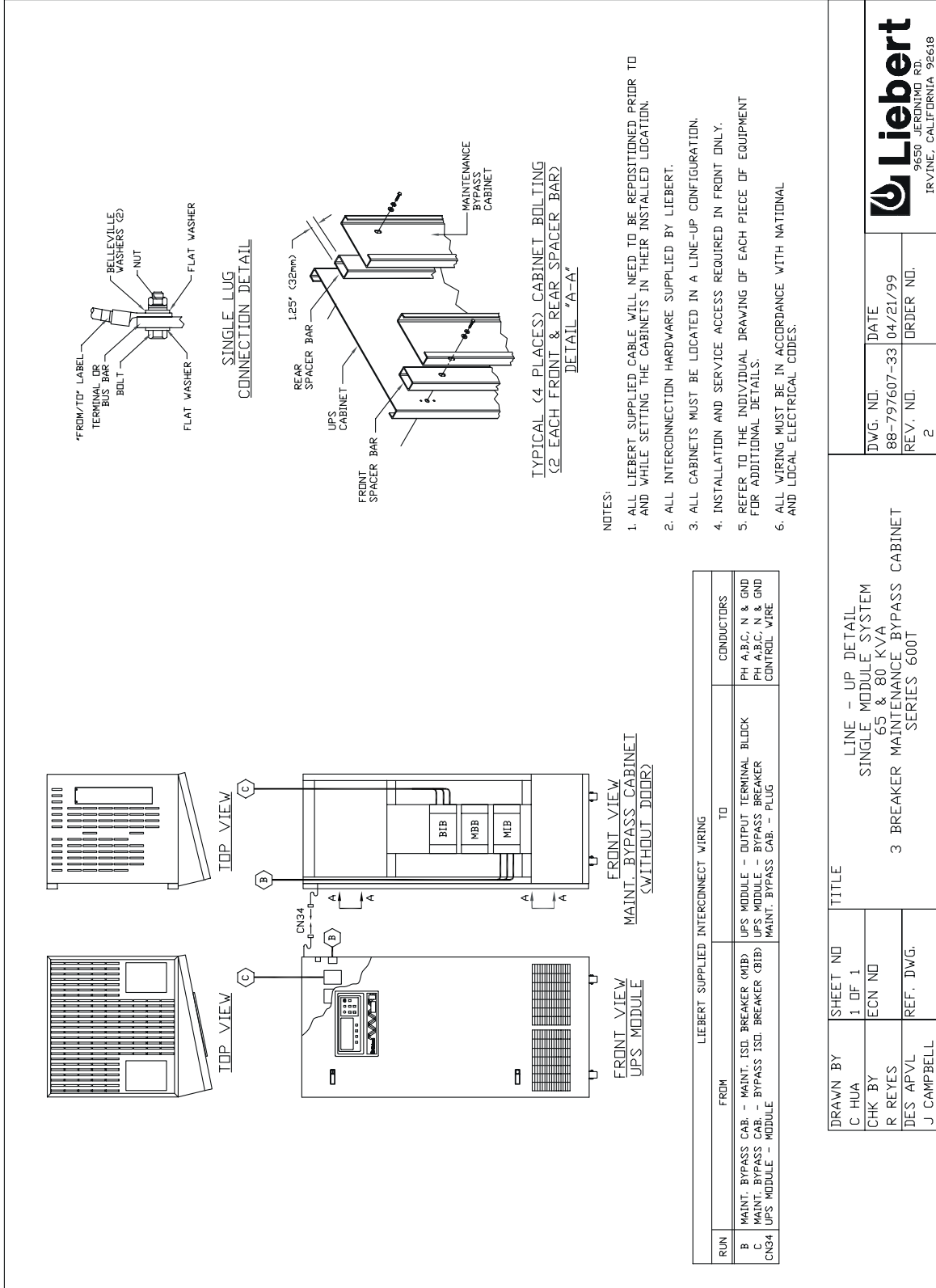

Figure 29. Line-up Detail, 65 & 80 kVA with 3-Breaker MBC

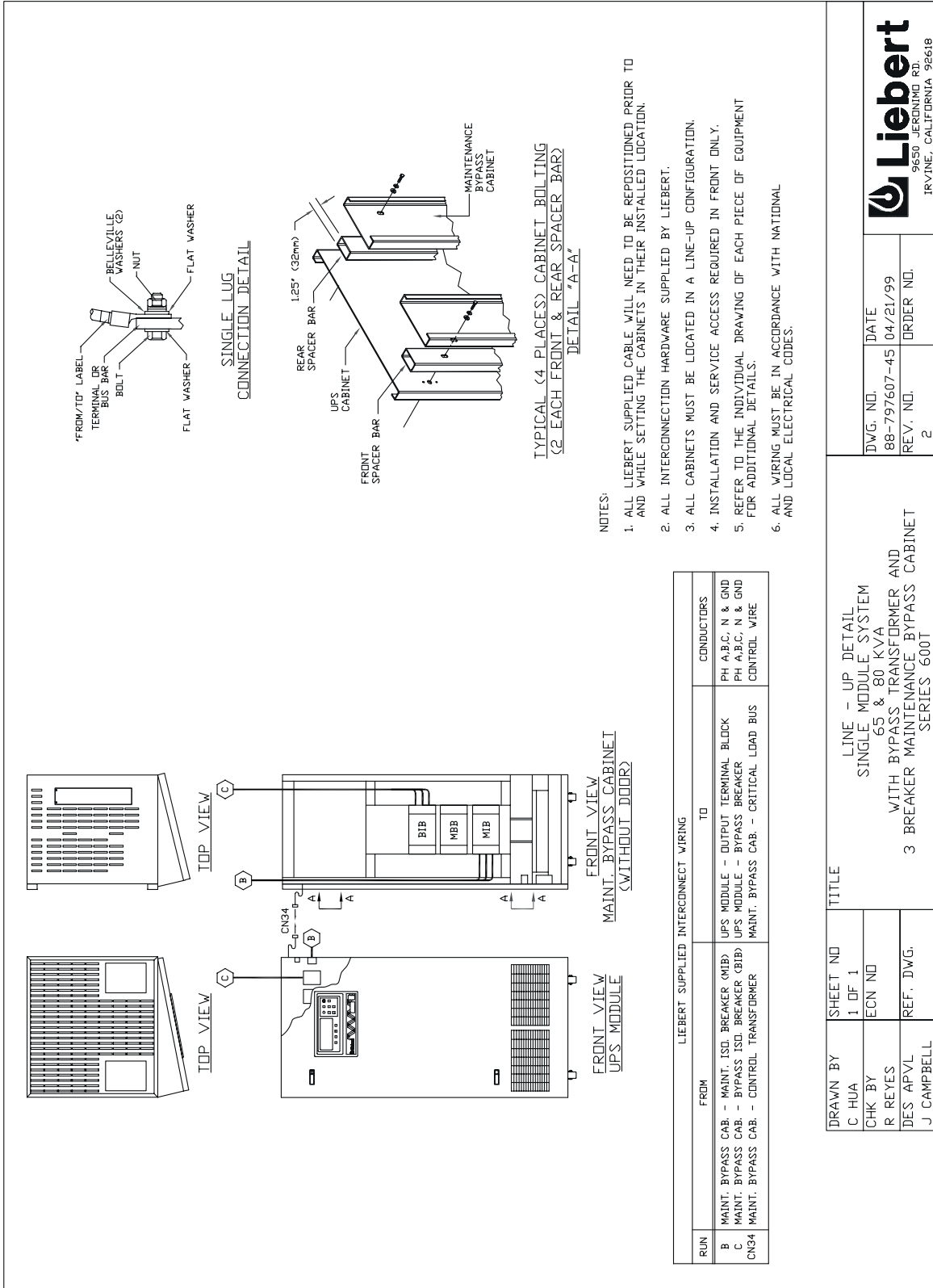

Figure 30. Line-up Detail, 65 & 80 kVA with Bypass Transformer and 3-Breaker MBC

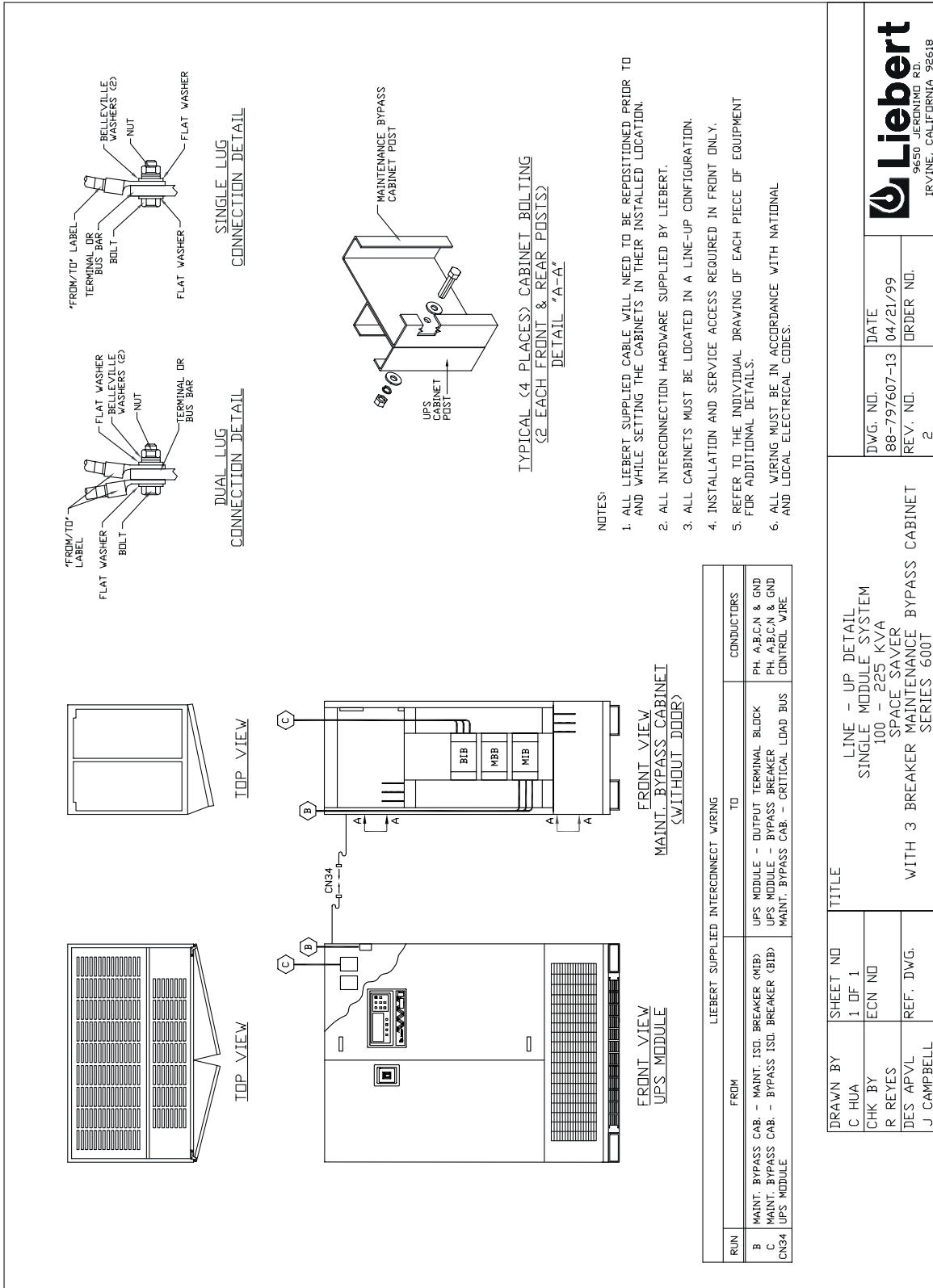

Figure 31. Line-up Detail, 100-225 kVA Space Saver with 3-Breaker MBC

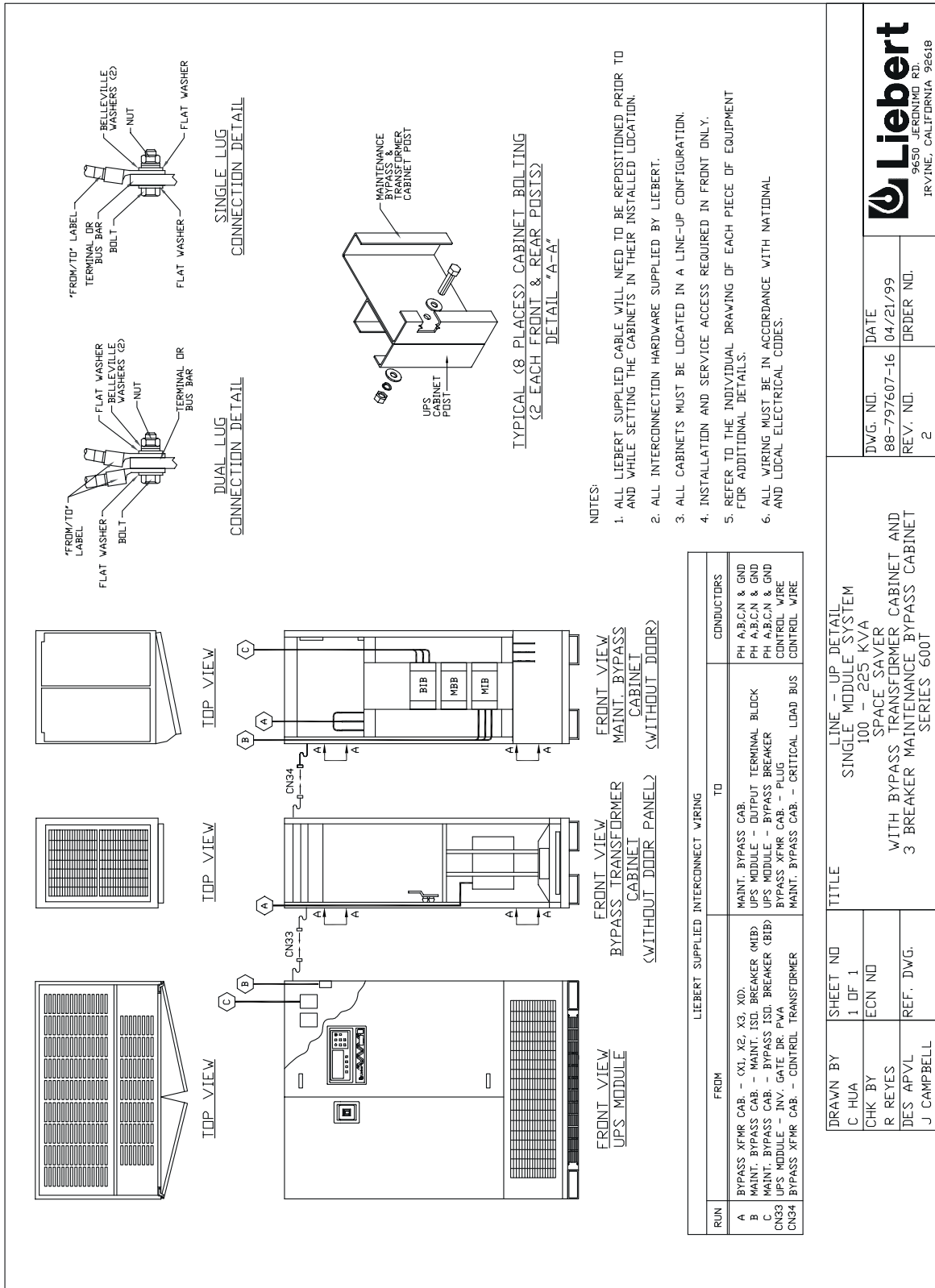

Figure 32. Line-up Detail, 100-225 kVA Space Saver with Bypass Transformer Cabinet and 3-Breaker MBC

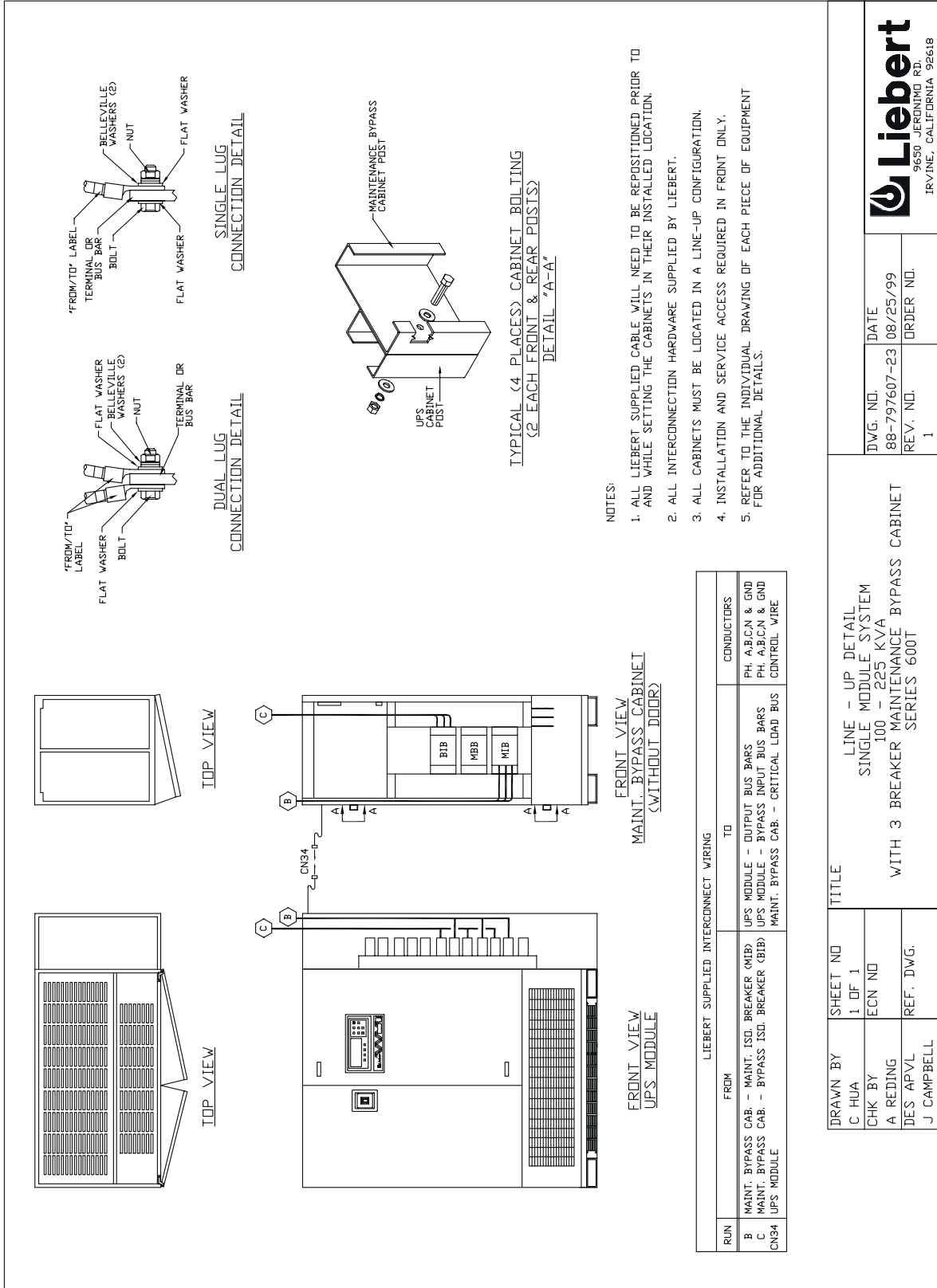

Figure 33. Line-up Detail, 100-225 kVA with 3-Breaker MBC

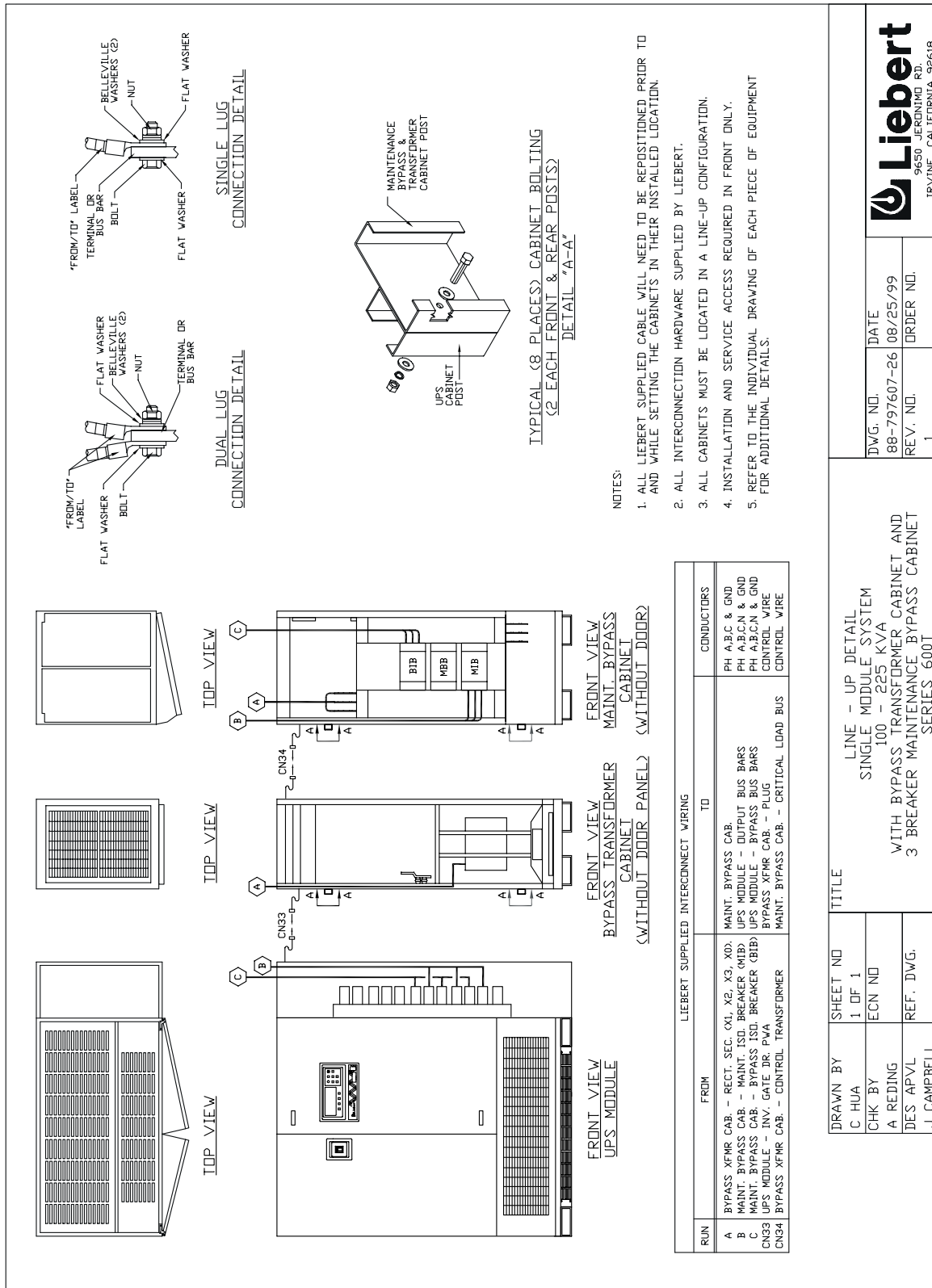

Figure 34. Line-up Detail, 100-225 kVA with Bypass Transformer Cabinet and 3-Breaker MBC

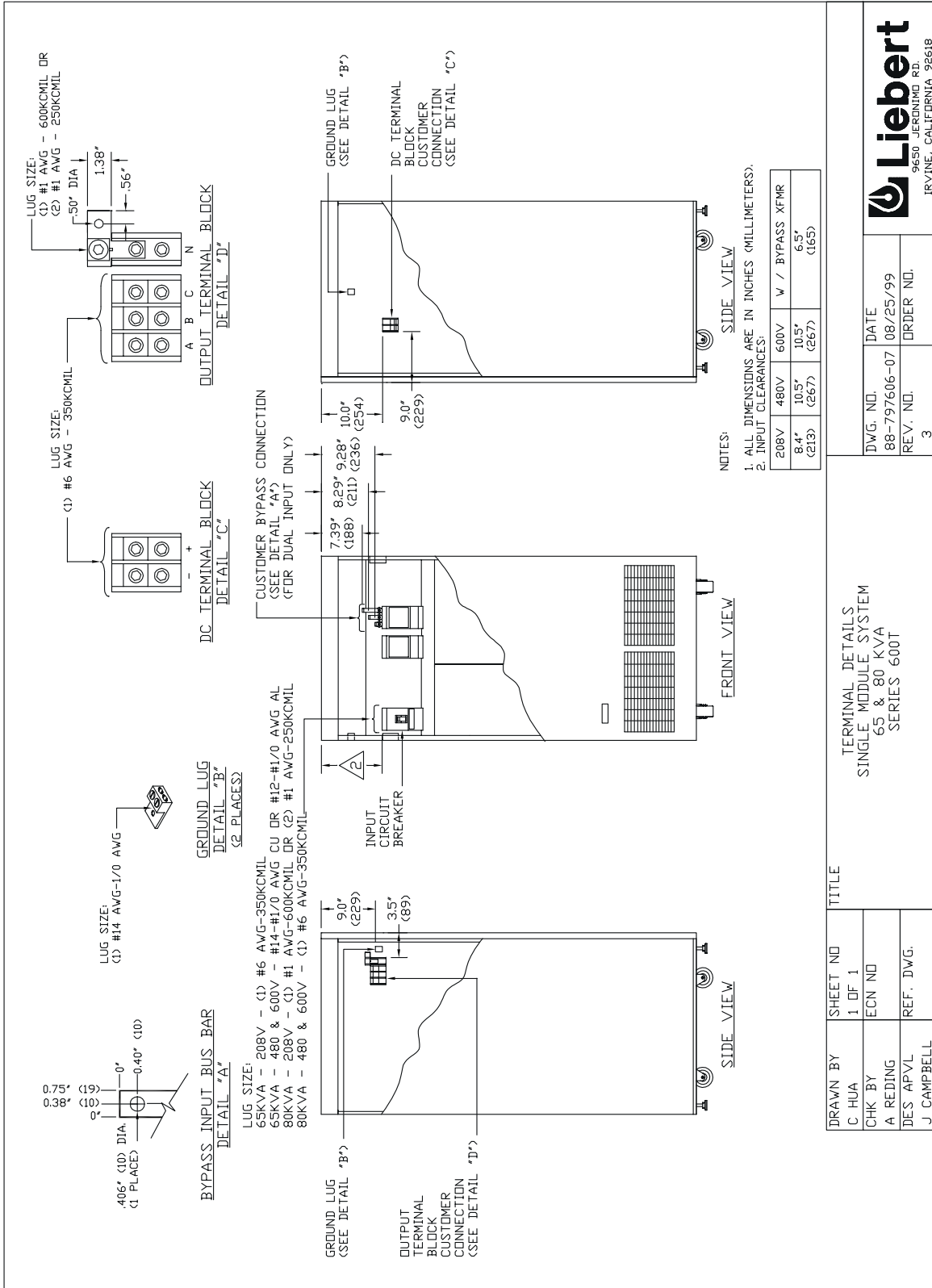

Figure 35. Terminal Details, 65 & 80 kVA Single Module Systems

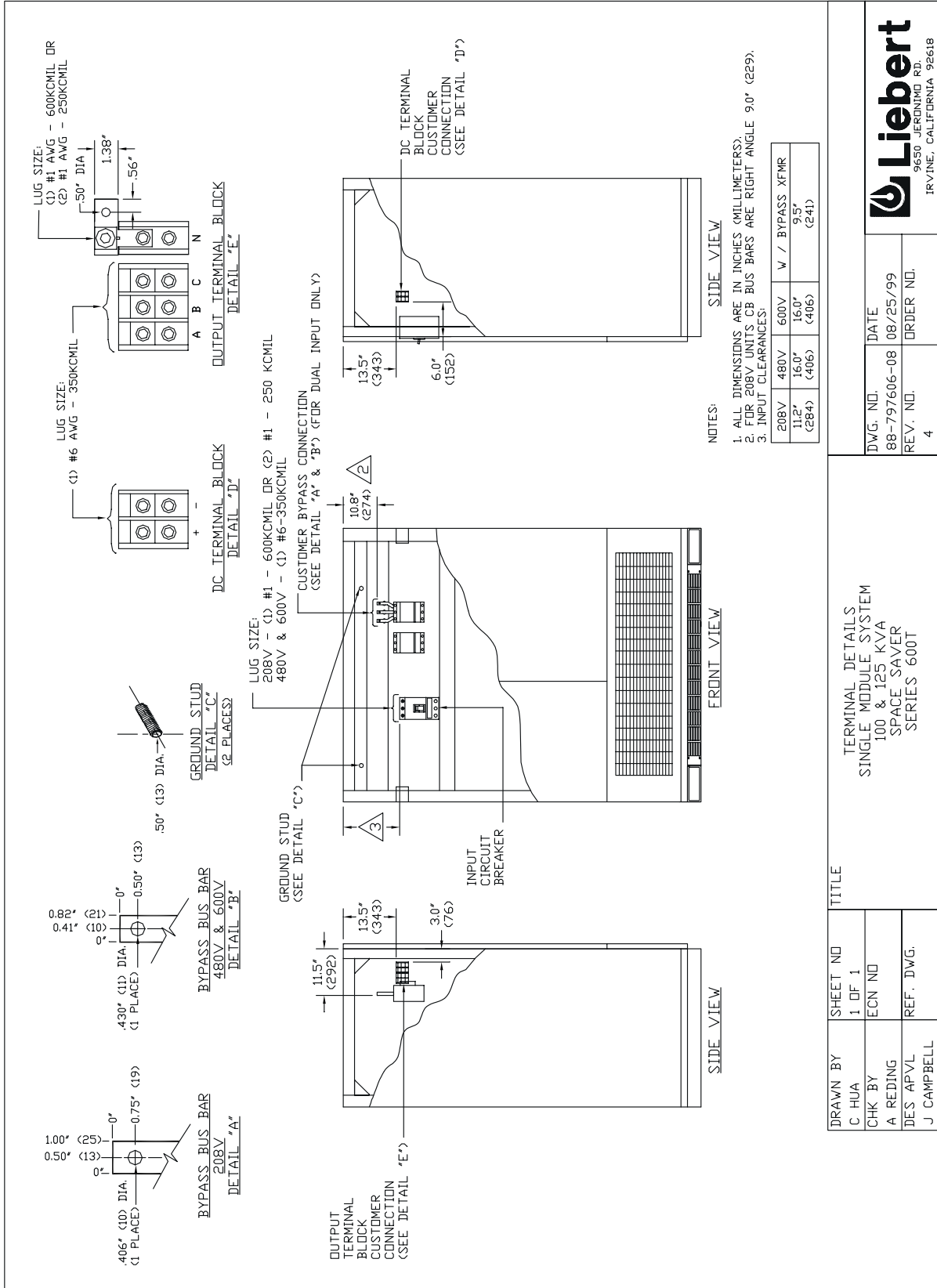

Figure 36. Terminal Details, 100 & 125 kVA Space Saver



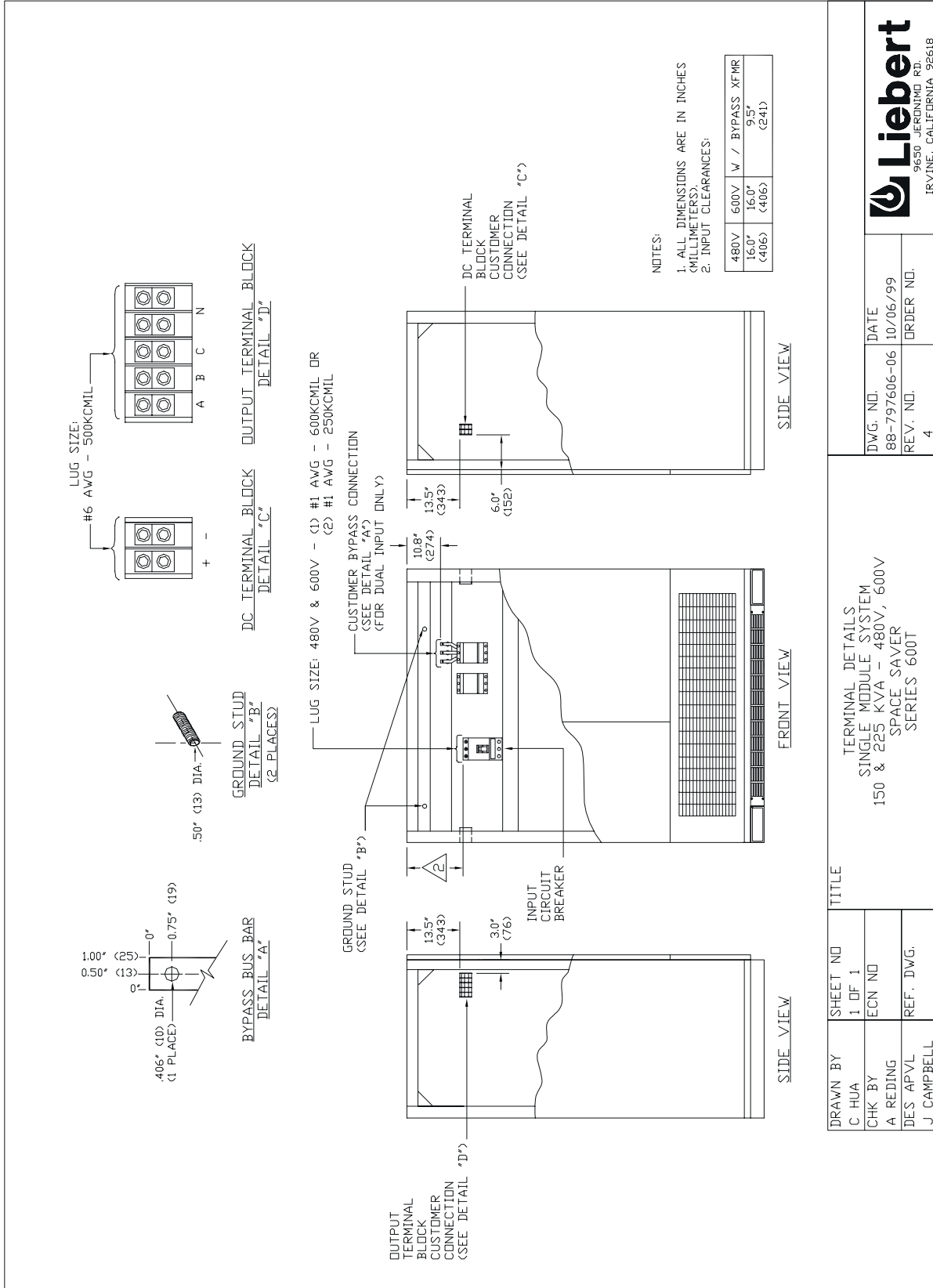
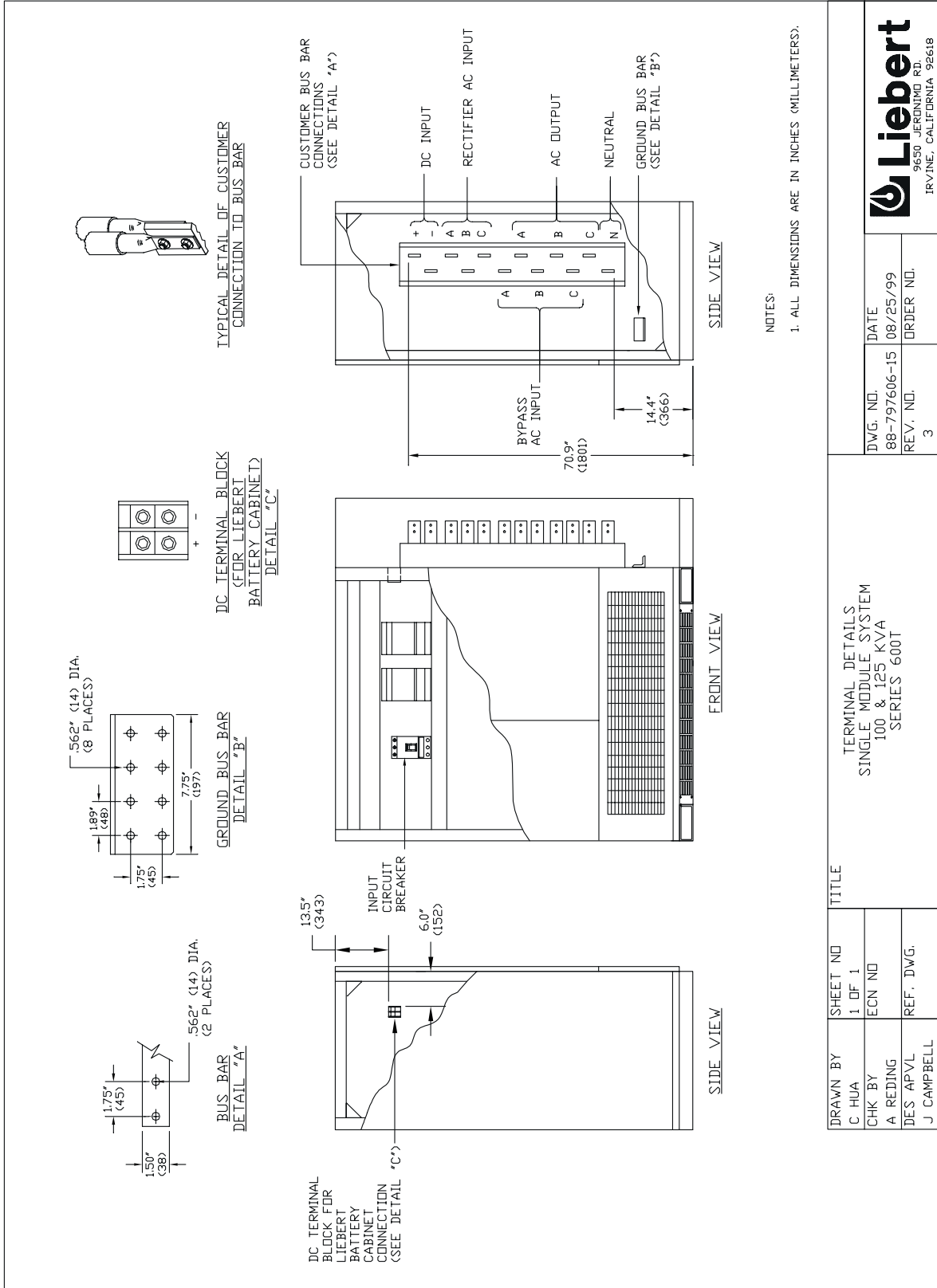

Figure 37. Terminal Details, 150 & 225 kVA Standard SMS



DRAWN BY C HUA		SHEET NO 1 OF 1		TITLE TERMINAL DETAILS SINGLE MODULE SYSTEM 100 & 125 KVA SERIES 600T	
CHK BY A REDING		ECN NO		DWG. NO. 88-797606-15	
DES APVL J CAMPBELL		REF. DWG.		DATE 08/25/99	
				REV. NO. 3	
				ORDER NO.	
				FILE NAME: 88-797606-15-03.DWG	



Figure 38. Terminal Details, 100 & 125 kVA Standard SMS

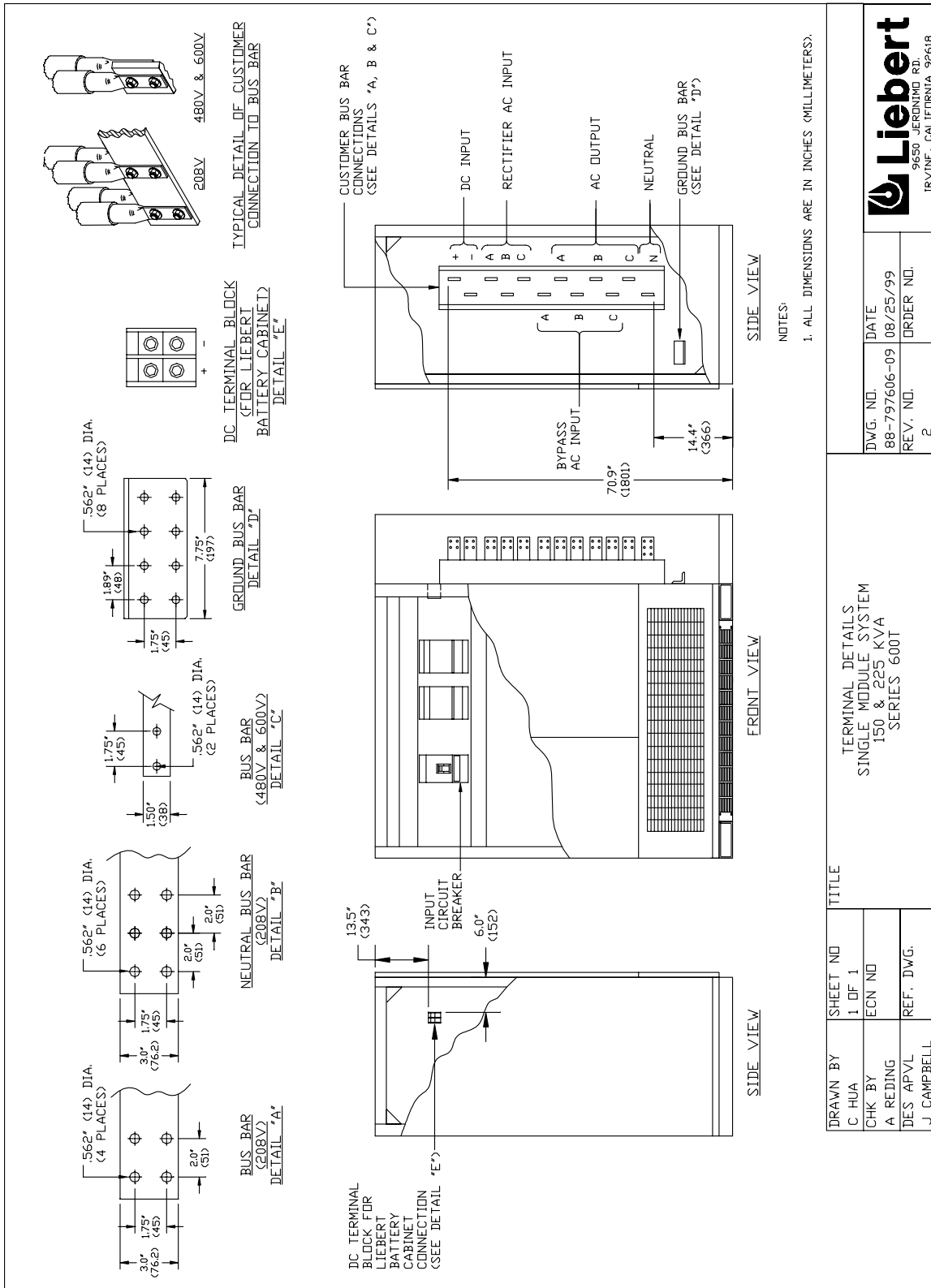

DRAWN BY C HUA		SHEET NO 1 OF 1		TITLE TERMINAL DETAILS SINGLE MODULE SYSTEM 150 & 225 KVA SERIES 600T	
CHK BY A REDING		ECN NO		DWG. NO. 88-797606-09	
DES APVL J CAMPBELL		REF. DWG.		DATE 08/25/99	
				ORDER NO.	
				REV. NO. 2	
				FILE NAME: 88-797606-09-02.DWG	



Figure 39. Terminal Details, 150 & 225 kVA Standard SMS

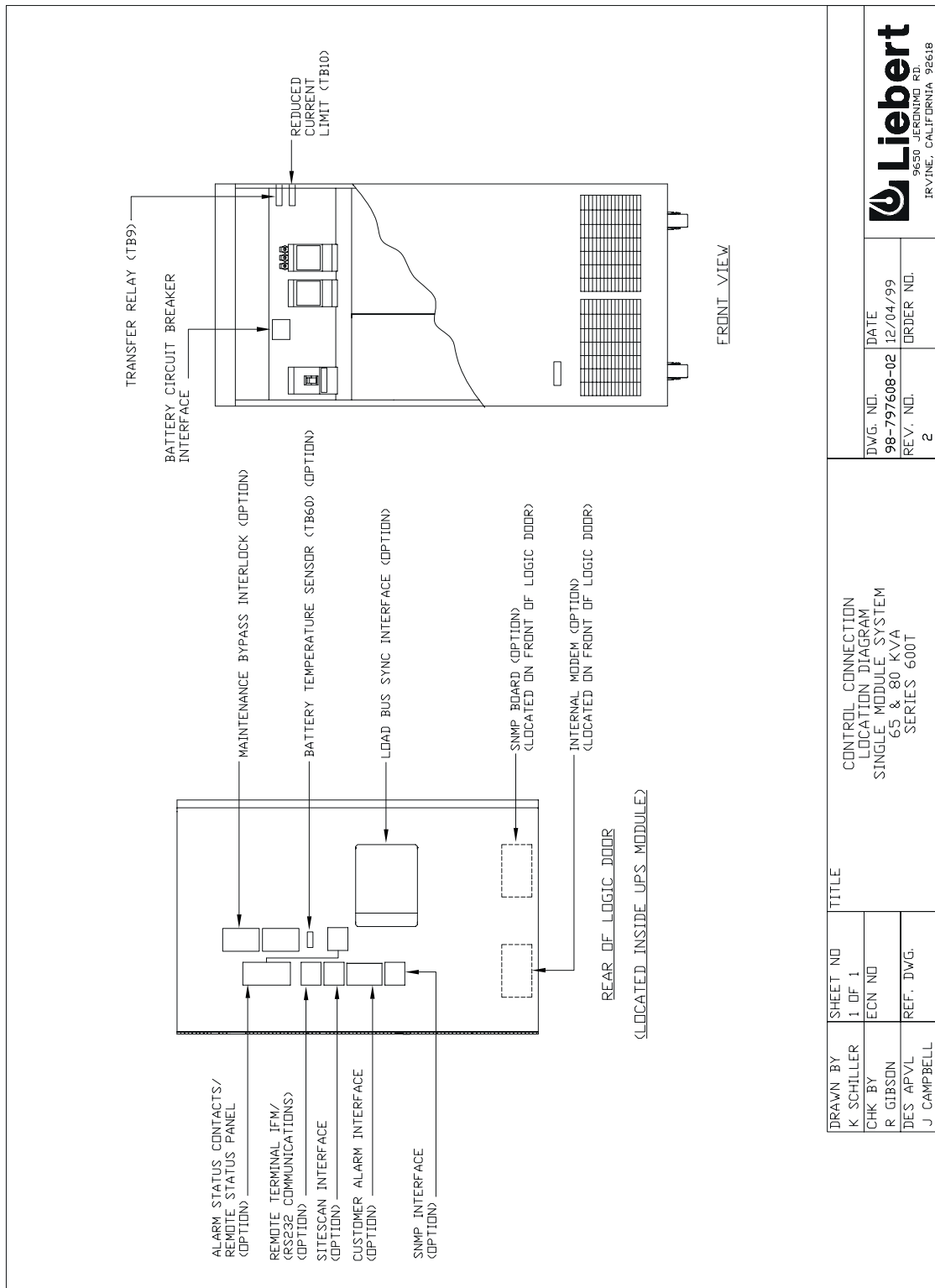

DWG. NO.	DATE
98-797608-02	12/04/99
REV. NO.	ORDER NO.
2	

DRAWN BY		SHEET NO		TITLE	
K SCHILLER		1 OF 1		CONTROL CONNECTION	
CHK BY		ECN NO		LOCATION DIAGRAM	
R GIBSON				SINGLE MODULE SYSTEM	
DES APVL		REF. DWG.		65 & 80 KVA	
J CAMPBELL				SERIES 600T	

FILE NAME: 98-797608-02-02.DWG  
 92618  
 IRVINE, CALIFORNIA

Figure 40. Control Connection Locations, 65 & 80 kVA

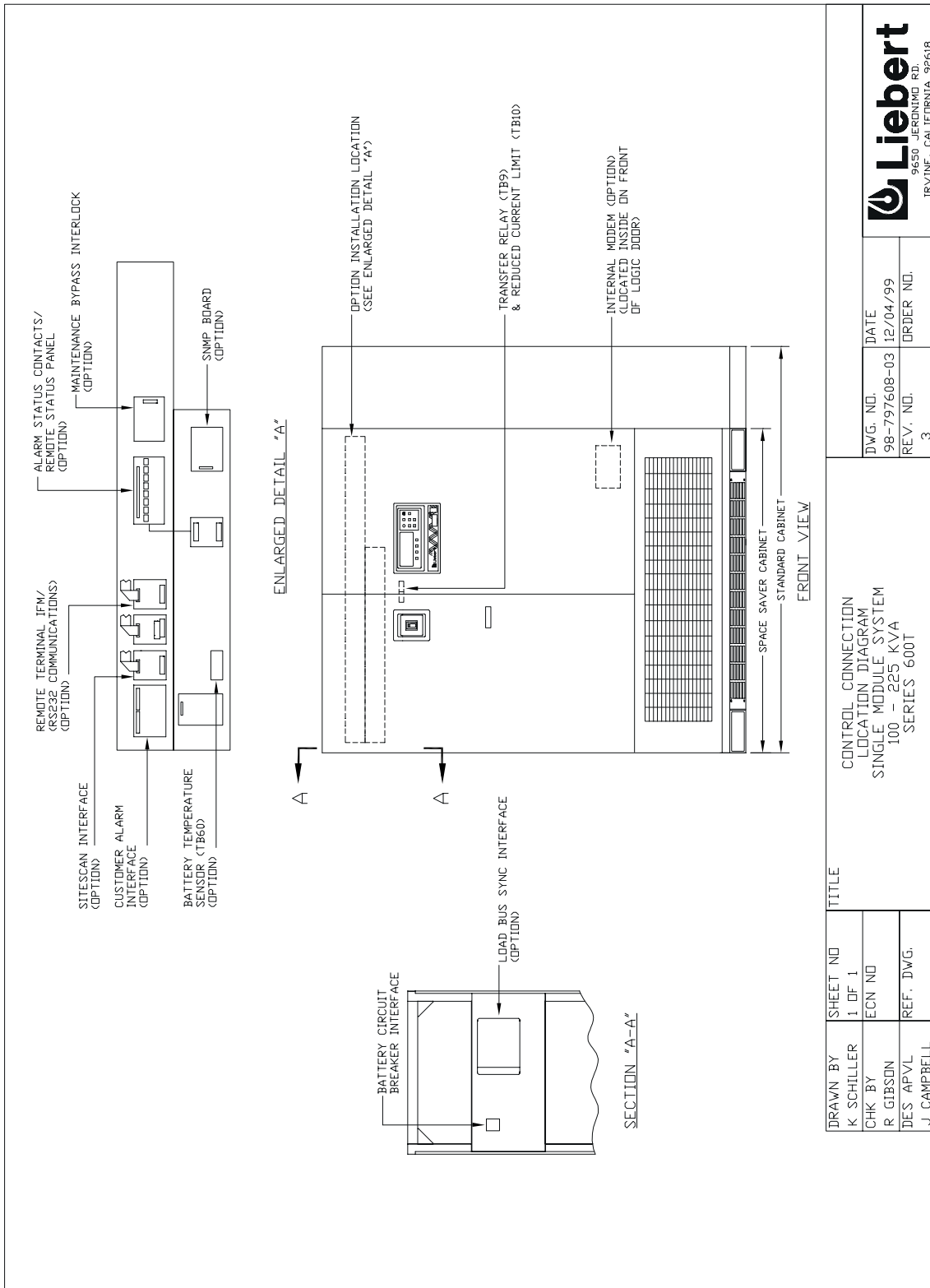

DWG. NO. 98-797608-03  
DATE 12/04/99  
REV. NO. 3  
ORDER NO.

FILE NAME: 98-797608-03.DWG

Figure 41. Control Connection Locations, 100 through 225 kVA

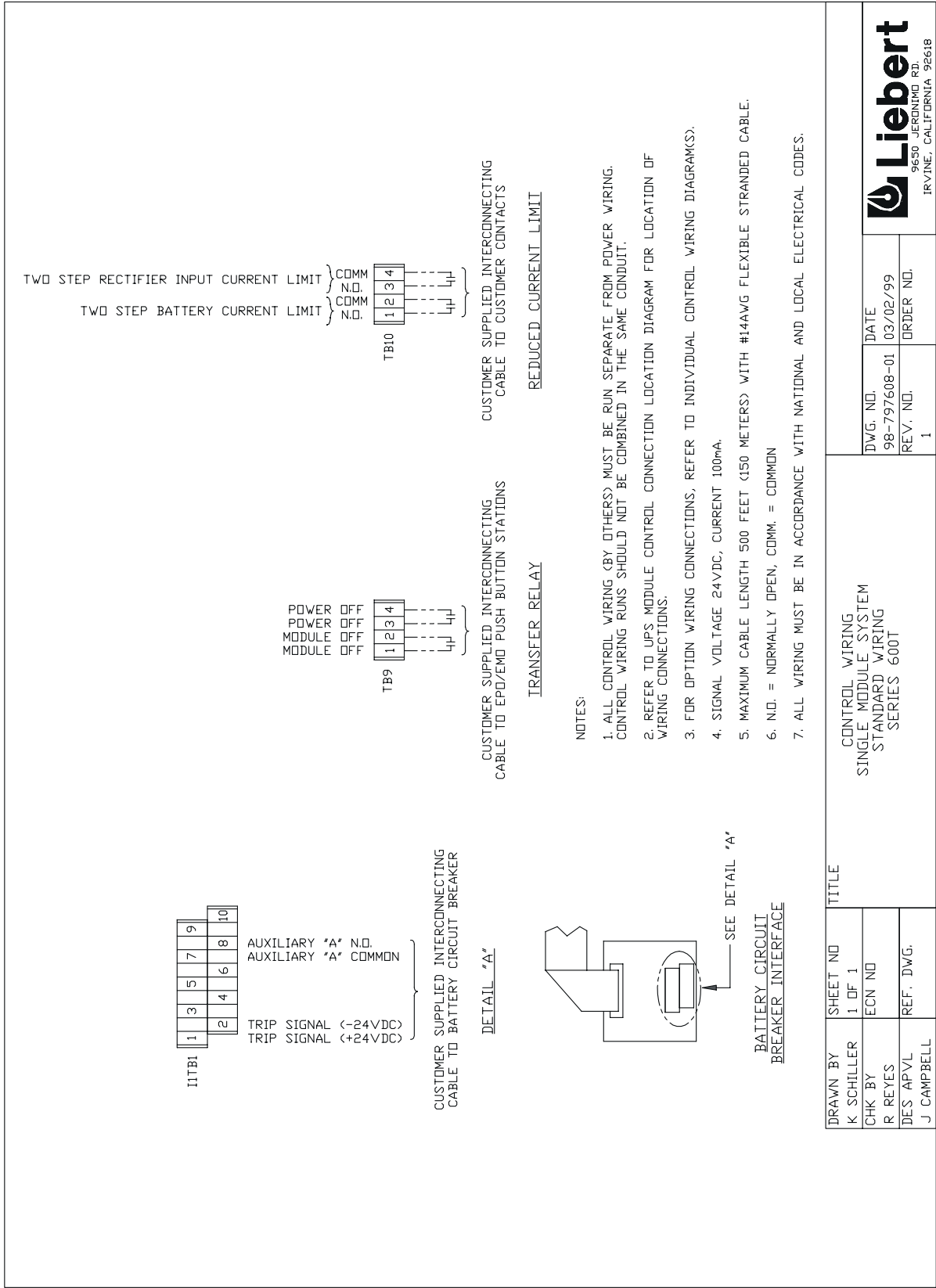

Figure 42. Standard Control Wiring, Single Module System

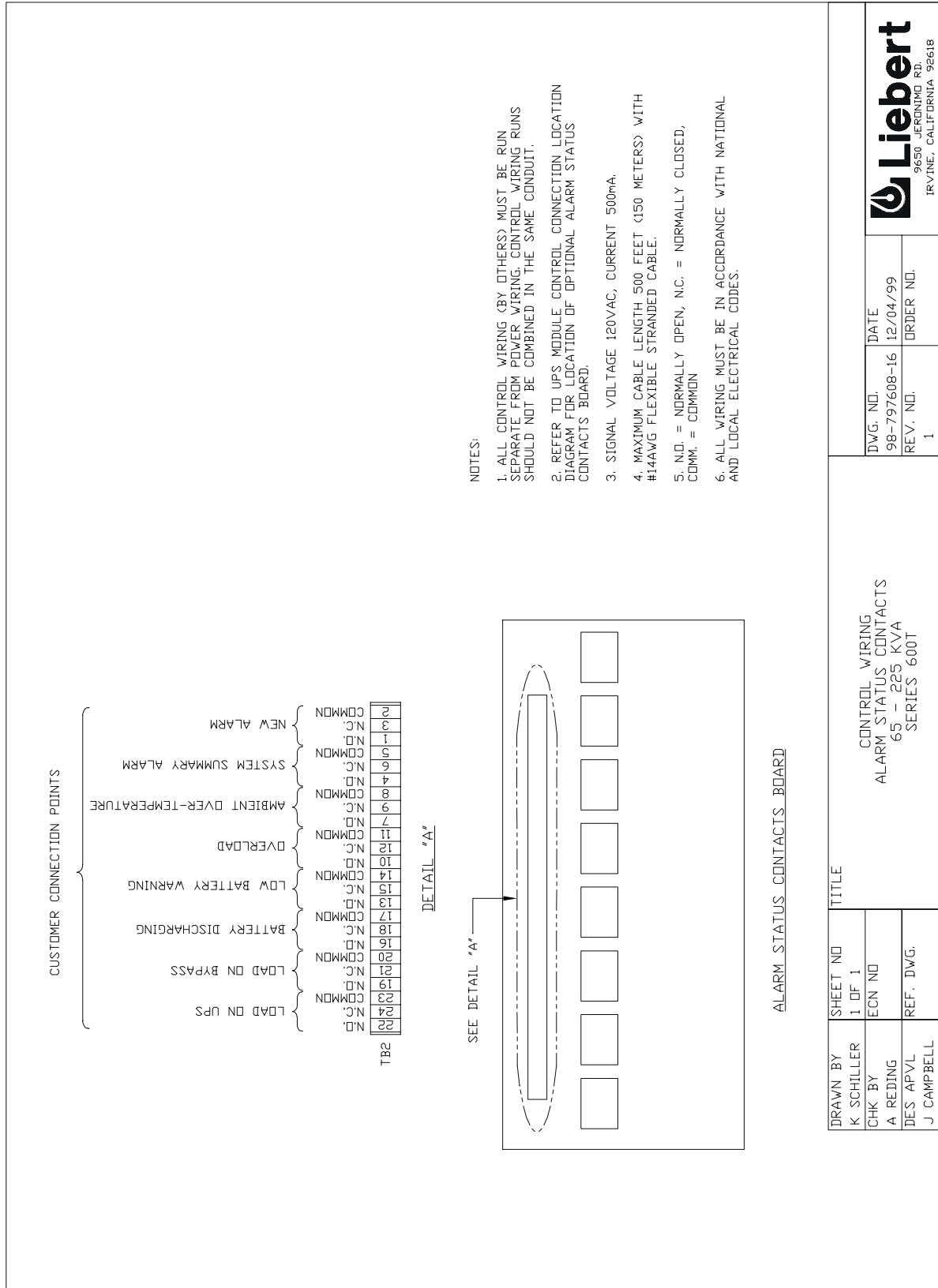

Figure 43. Option Wiring, Alarm Status Contacts

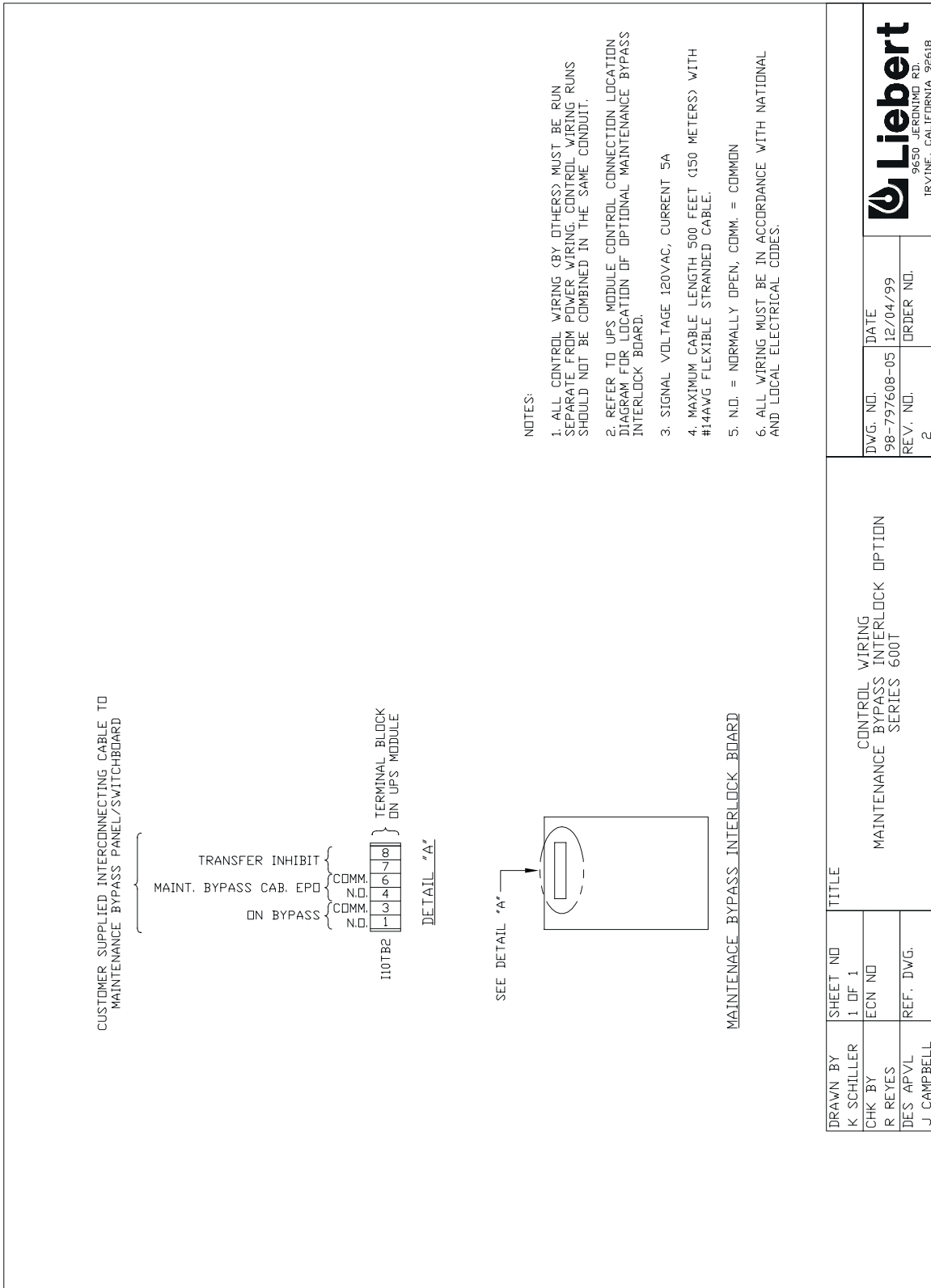

Figure 44. Option Wiring, Maintenance Bypass Interlock



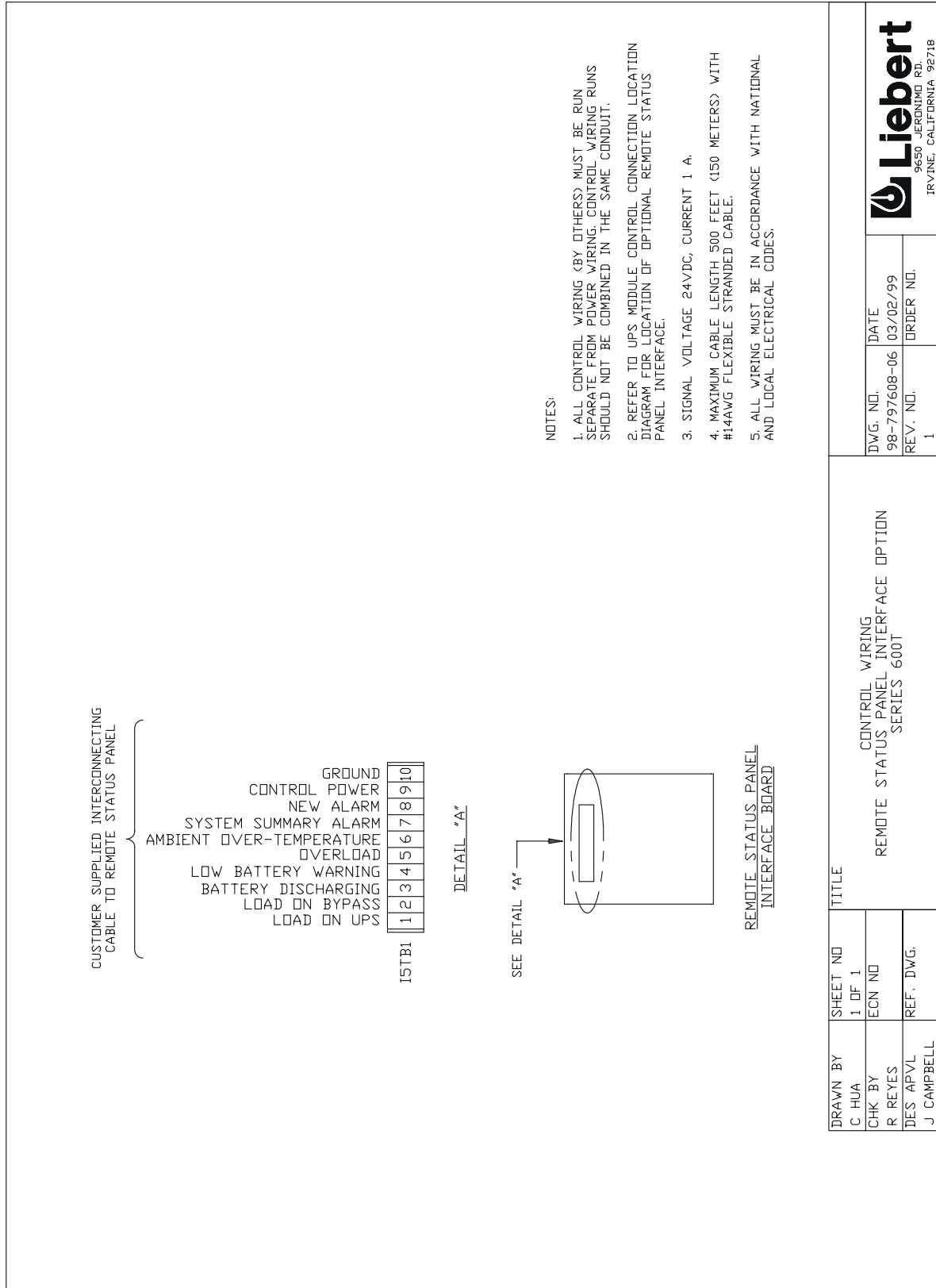

Figure 45. Option Wiring, Remote Status Panel Interface

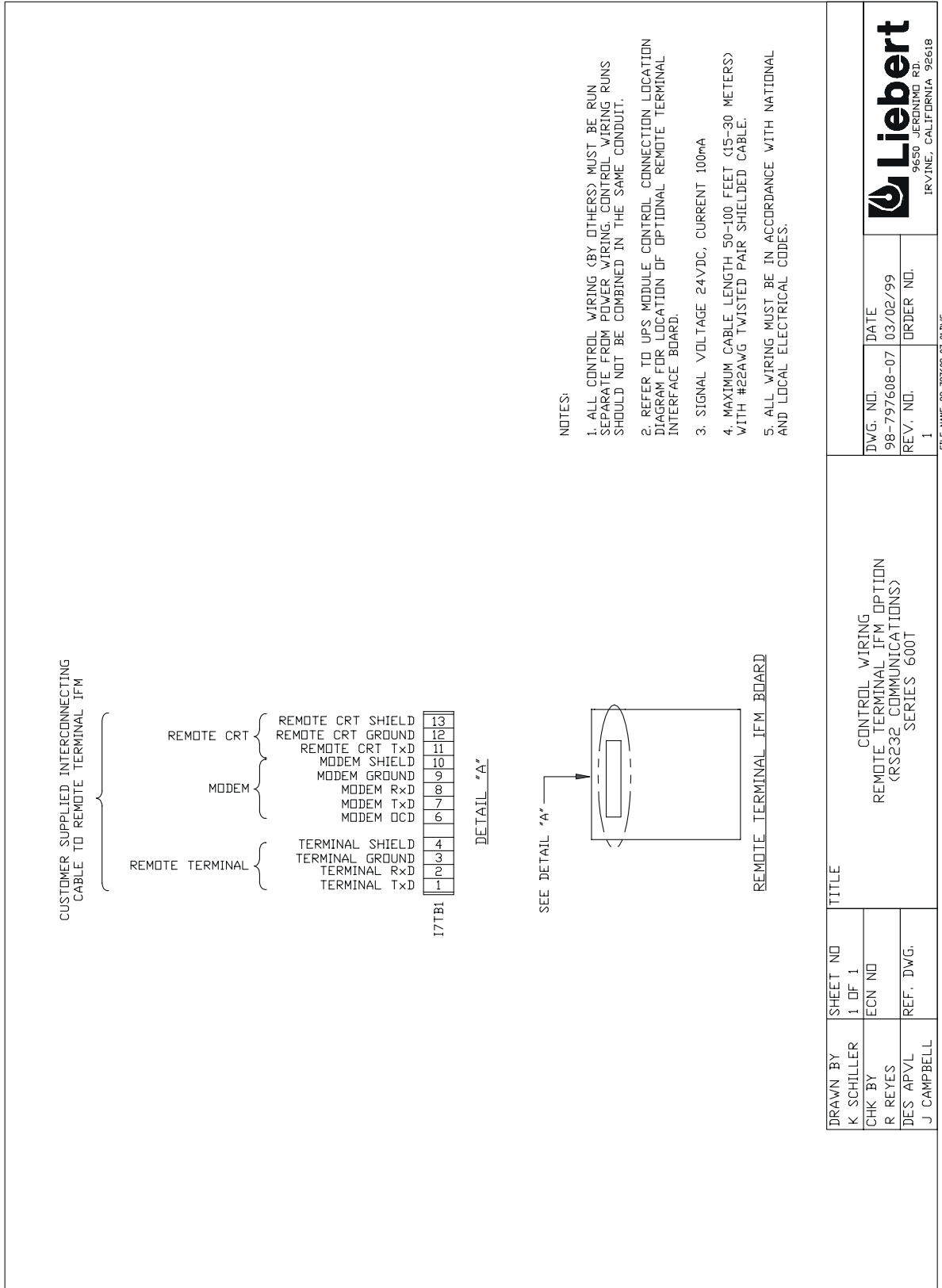

Figure 46. Option Wiring, Remote Terminal IFM (RS-232 Communications)

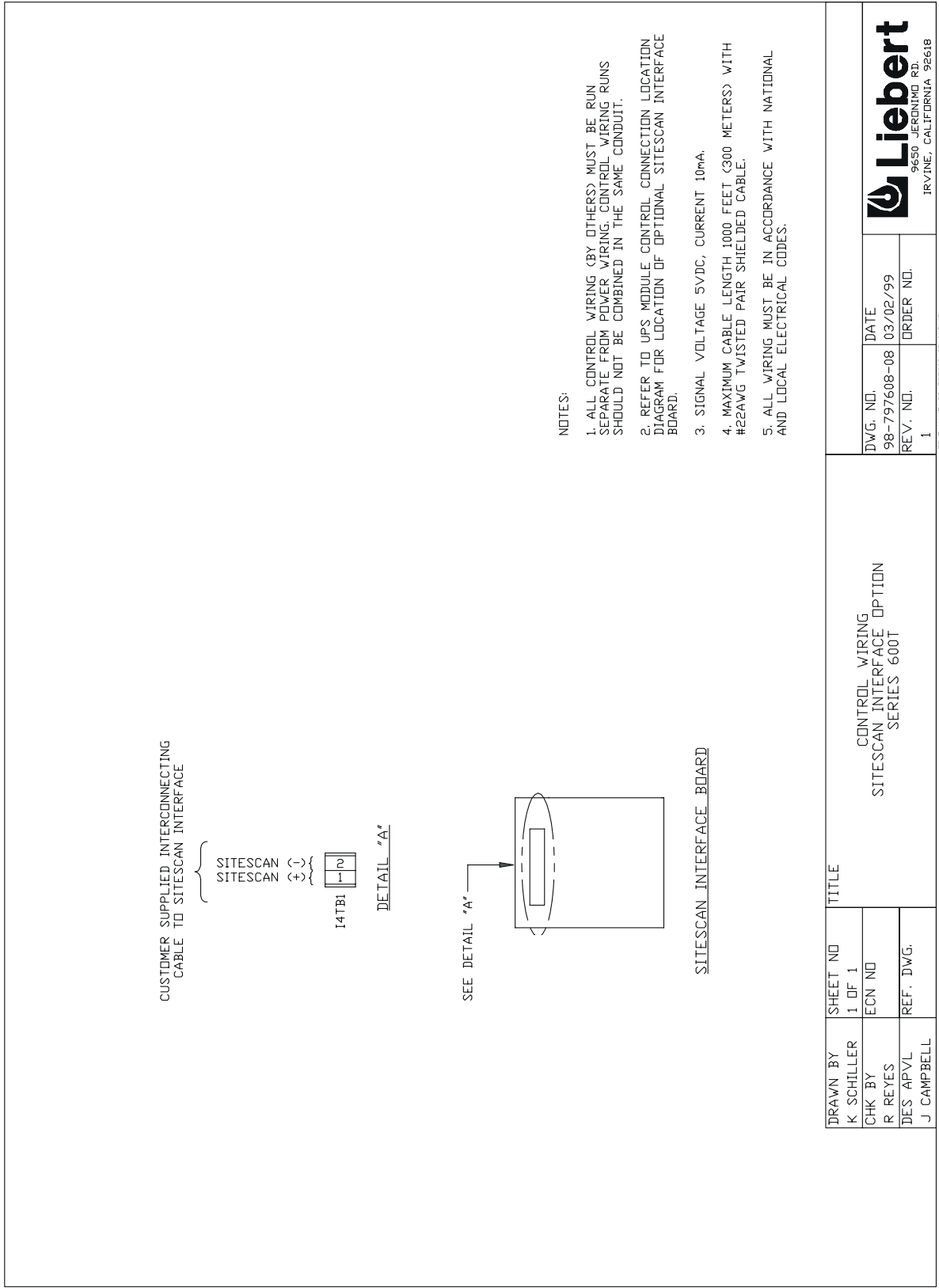

Figure 47. Option Wiring, SiteScan Interface

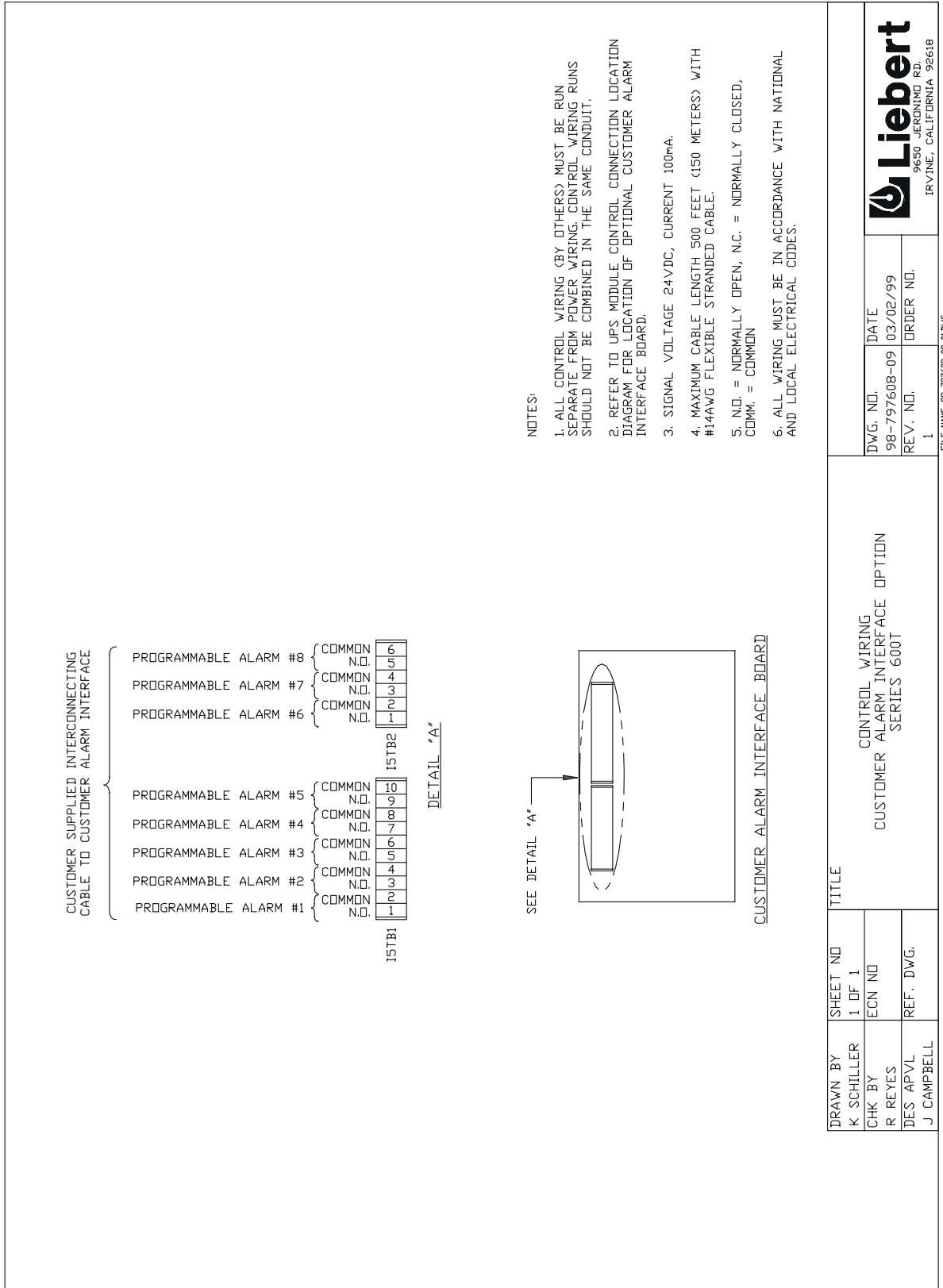

Figure 48. Option Wiring, Customer Alarm Interface

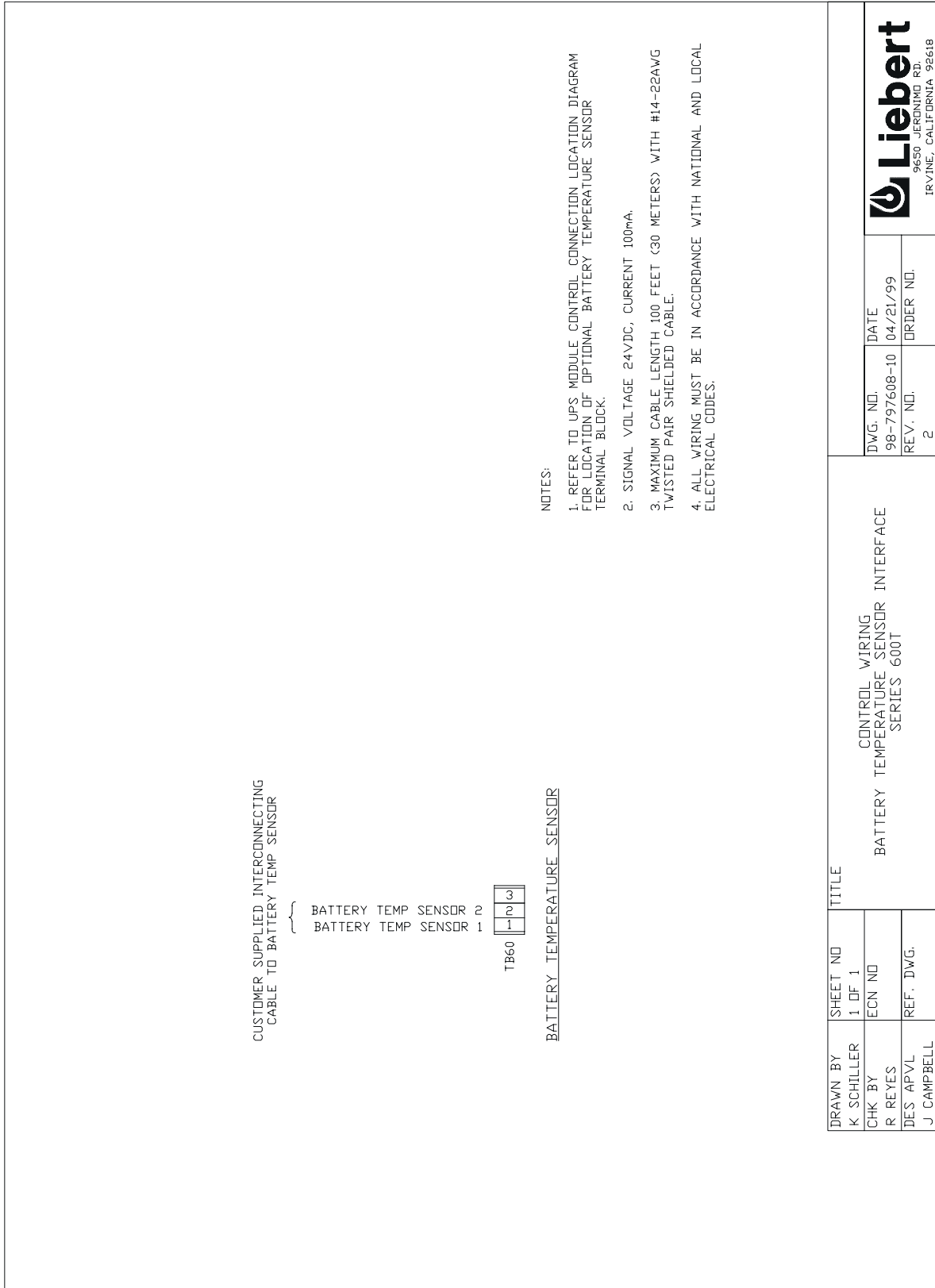

Figure 49. Option Wiring, Battery Temperature Sensor

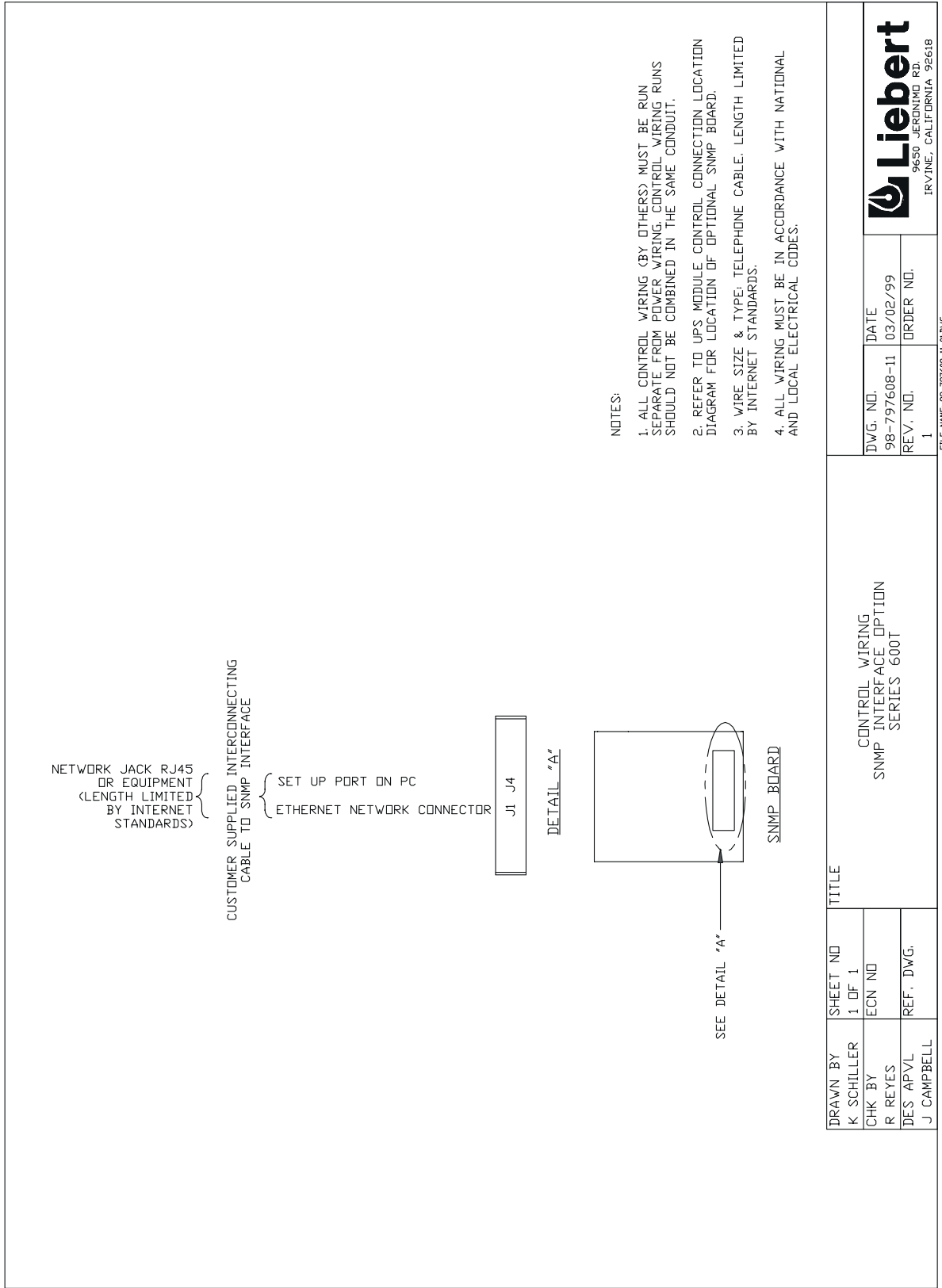
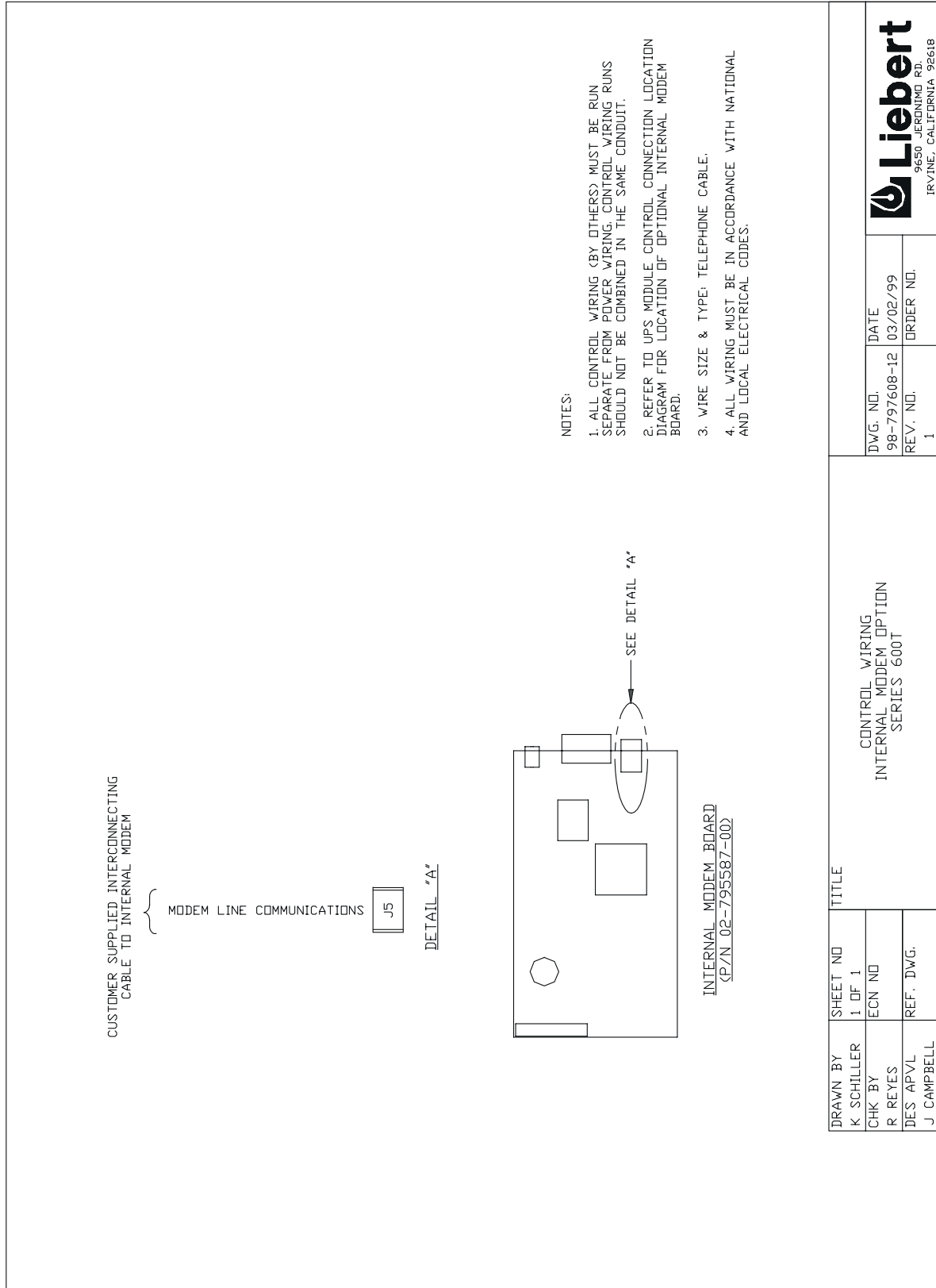

Figure 50. Option Wiring, SNMP Interface



DRAWN BY K SCHILLER		SHEET NO 1 OF 1		TITLE CONTROL WIRING INTERNAL MODEM OPTION SERIES 600T	
CHK BY R REYES		ECN NO		DWG. NO. 98-797608-12	
DES APVL J CAMPBELL		REF. DWG.		DATE 03/02/99	
				REV. NO. 1	
				ORDER NO.	



FILE NAME 98-797608-12-01.DWG

Figure 51. Option Wiring, Internal Modem

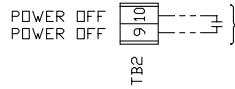

CUSTOMER SUPPLIED INTERCONNECTING  
CABLE TO EPD/EMO PUSH BUTTON STATIONS  
REMOTE EMERGENCY POWER OFF

NOTES:

1. ALL CONTROL WIRING (BY OTHERS) MUST BE RUN SEPARATE FROM POWER WIRING. CONTROL WIRING RUNS SHOULD NOT BE COMBINED IN THE SAME CONDUIT.
2. REFER TO MAINTENANCE BYPASS CABINET OUTLINE DRAWING FOR LOCATION OF WIRING CONNECTIONS.
3. SIGNAL VOLTAGE 120VAC, CURRENT 5A.
4. MAXIMUM CABLE LENGTH 500 FEET (150 METERS) WITH #14AWG FLEXIBLE STRANDED CABLE.
5. ALL WIRING MUST BE IN ACCORDANCE WITH NATIONAL AND LOCAL ELECTRICAL CODES.

DRAWN BY K. SCHILLER	SHEET NO 1 OF 1	TITLE CONTROL WIRING MAINTENANCE BYPASS CABINET OPTION SERIES 600T	
	CHK BY R. REYES		
DES APVL J. CAMPBELL	REF. DWG.	DWG. NO. 98-797608-14	DATE 04/21/99
		REV. NO. 1	ORDER NO.



FILE NAME 98-797608-14-01.DWG

Figure 52. Option Wiring, Maintenance Bypass Cabinet





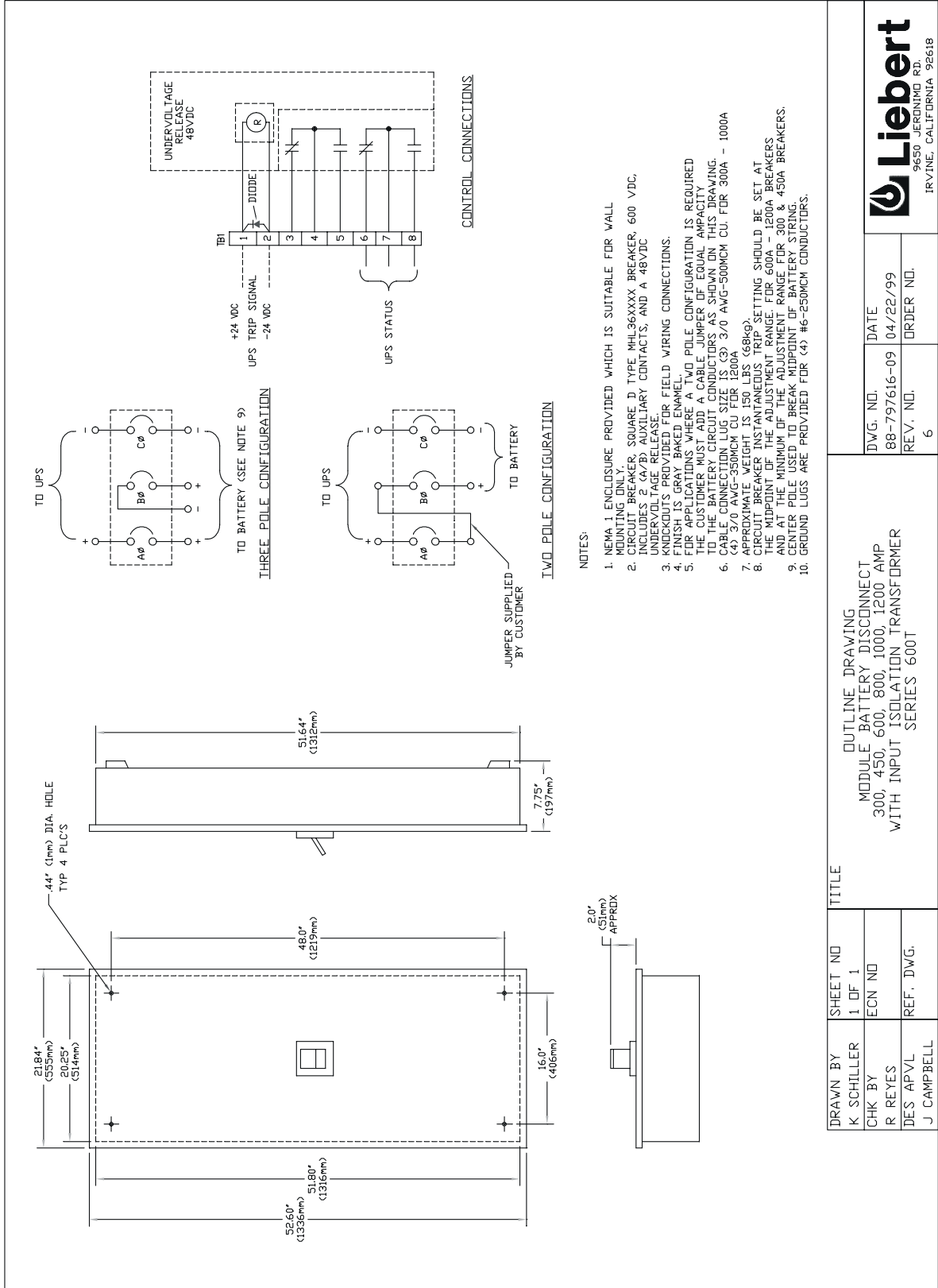

Figure 54. Module Battery Disconnect, 150 & 225 kVA



9650 JEROME RD.  
IRVINE, CALIFORNIA 92618

DWG. NO.	DATE
88-797616-09	04/22/99
REV. NO.	ORDER NO.
6	

FILE NAME: 88-797616-09-06.DWG

TITLE

DRAWN BY	SHEET NO
K SCHILLER	1 OF 1
CHK BY	ECN NO
R REYES	
DES APVL	REF. DWG.
J CAMPBELL	

OUTLINE DRAWING  
MODULE BATTERY DISCONNECT  
300, 450, 600, 800, 1000, 1200 AMP  
WITH INPUT ISOLATION TRANSFORMER  
SERIES 600T

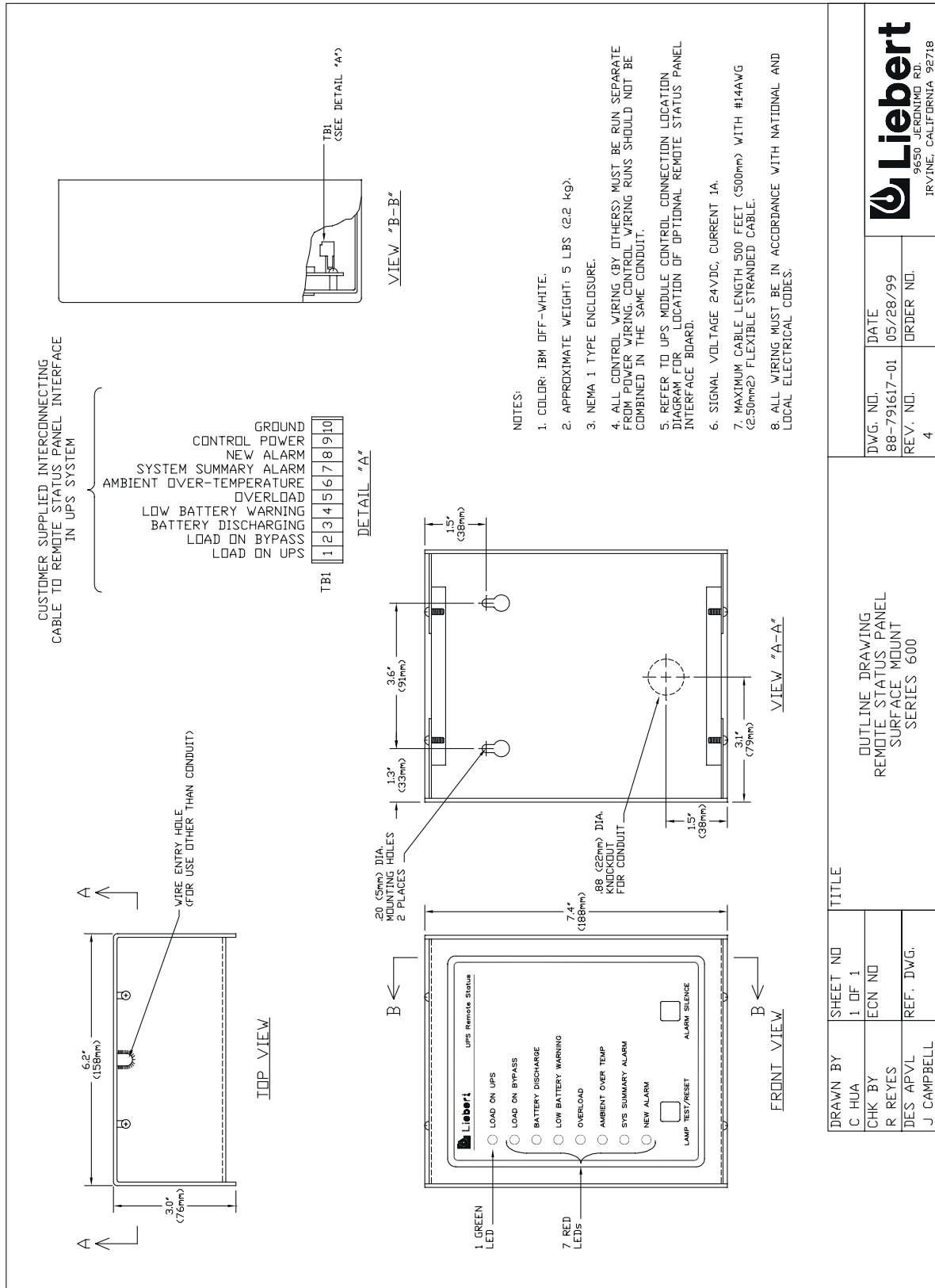

Figure 55. Remote Status Panel, Surface Mount

SERIES 600T SINGLE MODULE CIRCUIT BREAKER SCHEDULE									
INPUT CIRCUIT BREAKER (CB1)					OUTPUT (CB2) / BYPASS (CB3) CIRCUIT BREAKER				
USAGE KVA/KW	VOLTAGE IN	VENDOR	TYPE	INTERRUPTING RATING AIC	VOLTAGE OUT	VENDOR	TYPE	INTERRUPTING RATING AIC	
65/52	208V	SQUARE D	KHL	65K	208V 480V 600V	MERLIN GERIN	NFHF	100K	
	480V		FHL	25K			NFHF	65K	
80/64	208V	SQUARE D	LHL	65K	208V 480V 600V	MERLIN GERIN	NFHF	100K	
	480V		KHL	35K			NFHF	65K	
100/80	208V	SQUARE D	LHL	65K	208V 480V 600V	MERLIN GERIN	NJHF	100K	
	480V		KHL	35K			NFHF	65K	
125/100	208V	SQUARE D	MHL	65K	208V 480V 600V	MERLIN GERIN	NJHF	100K	
	480V		KHL	35K			NFHF	65K	
150/120	208V	SQUARE D	MHL	65K	208V 480V 600V	MERLIN GERIN	NJHF	100K	
	480V		KHL	35K			NFHF	65K	
225/180	208V	SQUARE D	MHL	65K	208V 480V 600V	MERLIN GERIN	CKHH	100K	
	480V		LHL	35K			NJHF	65K	
	600V		LHL	25K			NJHF	25K	

DRAWN BY	SHEET NO	TITLE
K SCHILLER	1 OF 1	CIRCUIT BREAKER SCHEDULE SINGLE MODULE UPS 65 - 225 KVA SERIES 600T
CHK BY	ECN NO	
R REYES		
DES APVL	REF. DWG.	
J CAMPBELL		



DWG. NO.	DATE
84-797605-108	04/21/99
REV. NO.	ORDER NO.
2	

FILE NAME: 84-797605-108-02.DWG

Figure 56. Circuit Breaker Schedule, 65 through 225 kVA

BATTERY CABINET CIRCUIT BREAKER SCHEDULE					
UPS KVA RATING	VENDOR	TYPE	FRAME AMPS	TRIP AMPS	
65, 80	SQUARE D	KHL36175-DC	250	175	
100, 125	SQUARE D	KHL36250-DC	250	250	
150	SQUARE D	MHL34300-DC	1000	300	
225, 300, 400, 450, 500	SQUARE D	MHL36450-DC	1000	450	

DRAWN BY K SCHILLER	SHEET NO 1 OF 1	TITLE CIRCUIT BREAKER SCHEDULE BATTERY CABINET 65 - 500 KVA SERIES 600T	DWG. NO.	DATE
			84-797605-110	04/21/99
CHK BY R REYES	ECN NO		REV. NO.	ORDER NO.
DES APVL J CAMPBELL	REF. DWG.		1	



FILE NAME 84-797605-110-01.DWG

Figure 57. Circuit Breaker Schedule, Battery Cabinets, 65 to 500 kVA

MAINTENANCE BYPASS CABINET CIRCUIT BREAKER SCHEDULE									
KVA/KW	VOLTAGE			RIB			BIB / MBB / MIB		
	INPUT	OUTPUT	VENDOR	TYPE	INTERRUPTING RATING AIC	VENDOR	TYPE	INTERRUPTING RATING AIC	
65/52	208V	208V	MERLIN GERIN	NFHF	100K	MERLIN GERIN	NFHF	100K	
	480V	480V	MERLIN GERIN	NFHF	65K	MERLIN GERIN	NFHF	65K	
	600V	600V	MERLIN GERIN	NFHF	25K	MERLIN GERIN	NFHF	25K	
80/64	208V	208V	MERLIN GERIN	NJHF	100K	MERLIN GERIN	NJHF	100K	
	480V	480V	MERLIN GERIN	NFHF	65K	MERLIN GERIN	NFHF	65K	
	600V	600V	MERLIN GERIN	NFHF	25K	MERLIN GERIN	NFHF	25K	
100/80	208V	208V	MERLIN GERIN	NJHF	100K	MERLIN GERIN	NJHF	100K	
	480V	480V	MERLIN GERIN	NFHF	65K	MERLIN GERIN	NFHF	65K	
	600V	600V	MERLIN GERIN	NFHF	25K	MERLIN GERIN	NFHF	25K	
125/100	208V	208V	MERLIN GERIN	NJHF	100K	MERLIN GERIN	NJHF	100K	
	480V	480V	MERLIN GERIN	NFHF	65K	MERLIN GERIN	NFHF	65K	
	600V	600V	MERLIN GERIN	NFHF	25K	MERLIN GERIN	NFHF	25K	
150/120	208V	208V	SQUARE D	MHL	65K	SQUARE D	MHL	65K	
	480V	480V	SQUARE D	KHL	35K	SQUARE D	KHL	35K	
	600V	600V	SQUARE D	KHL	25K	SQUARE D	KHL	25K	
225/180	208V	208V	SQUARE D	MHL	65K	SQUARE D	MHL	65K	
	480V	480V	SQUARE D	LHL	35K	SQUARE D	LHL	35K	
	600V	600V	SQUARE D	LHL	25K	SQUARE D	LHL	25K	

- NOTE:
1. CIRCUIT BREAKERS MBB AND MIB ARE SUPPLIED ON ALL MAINTENANCE BYPASS CABINETS.
  2. CIRCUIT BREAKER BIB IS SUPPLIED ON 3 AND 4 BREAKER MAINTENANCE BYPASS CABINETS ONLY.
  3. CIRCUIT BREAKER RIB IS SUPPLIED ON 4 BREAKER MAINTENANCE BYPASS CABINETS ONLY.
  4. RIB BREAKER IS BASED ON INPUT VOLTAGE.
  5. BIB, MBB, AND MIB BREAKERS ARE BASED ON OUTPUT VOLTAGE.

DRAWN BY	SHEET NO	TITLE
K SCHILLER	1 OF 1	CIRCUIT BREAKER SCHEDULE
CHK BY	ECN NO	MAINTENANCE BYPASS CABINET
R REYES		65 - 225 KVA
DES APVL	REF. DWG.	SERIES 600T
J CAMPBELL		



DWG. NO.	DATE
84-797605-111	04/21/99
REV. NO.	ORDER NO.
2	

FILE NAME: 84-797605-111-82.DWG

Figure 58. Circuit Breaker Schedule, Maintenance Bypass Cabinet, 65 through 225 kVA

## Appendix A: Site Planning Data 65-225 kVA Single Module Systems

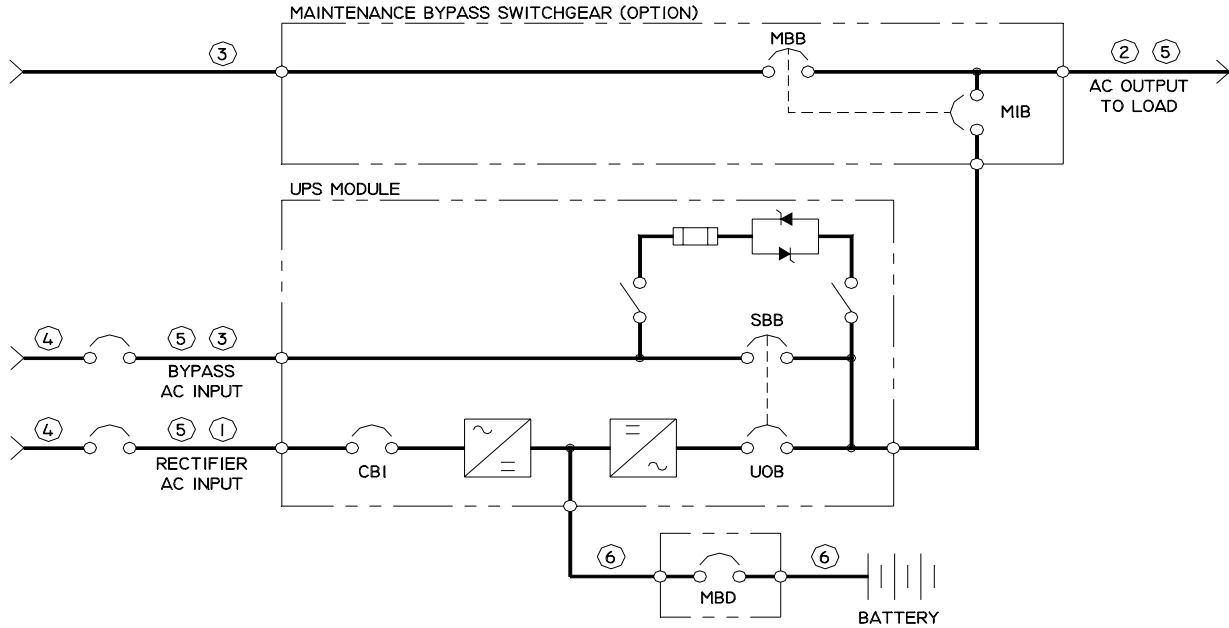

### Notes

1. Nominal rectifier AC input current (considered continuous) is based on full rated output load. Maximum current includes nominal input current and maximum battery recharge current (considered noncontinuous). Continuous and noncontinuous current limits are defined in NEC 100. Maximum input current is controlled by current limit setting which is adjustable. Values shown for maximum setting are 125% of nominal input current. Standard factory setting is 115%.
2. Nominal AC output current (considered continuous) is based on full rated output load. Maximum current includes nominal output current and overload current for 10 minutes.
3. Bypass AC input current (considered continuous) is based on full rated output load.
4. Feeder protection (by others in external equipment) for rectifier AC input and bypass AC input is recommended to be provided by separate overcurrent protection devices.
5. UPS output load cables must be run in separate conduit from input cables.
6. Power cable from module DC bus to battery should be sized for a total maximum 2.0 volt line drop (measured at the module) at maximum discharge current.
7. Grounding conductors to be sized per NEC 250-122. Neutral conductors to be sized for full capacity -- per NEC 310-15 (b)(4) -- for systems with 4-wire loads and half capacity for systems with 3-wire loads.
8. Rectifier AC Input: 3-phase, 3-wire, plus ground  
AC Output to Load: 3-phase, 3 or 4-wire, plus ground  
Bypass AC Input: 3-phase, 3 or 4-wire, plus ground  
Module DC Input from Battery: 2-wire, (positive and negative) plus ground
9. All wiring is to be in accordance with National and Local Electrical Codes.
10. Minimum overhead clearance is 2 feet above UPS.
11. Top and bottom cable entry standard through removable access plates. However, SpaceSaver versions of the 100-225 kVA modules are 8" narrower (48" vs. 56") and are top-entry only. Tables show SpaceSaver modules, where available. Cut access plates to suit conduit size.
12. Control wiring and power cables must be run in separate conduits. Control wiring must be stranded tinned conductors.
13. 7% maximum reflected input harmonic current and 0.92 lagging input power factor at full load with optional input filter.

## Series 600T Single Module Systems 208 Volt Input

UPS Rating		AC Output Voltage	Options		Rectifier AC Input Current		Inverter Or Bypass AC Output Current		Required Battery Disconnect Rating Amperes	Maximum Battery Current At End Of Discharge Amperes	Maximum Heat Dissipation BTU/Hr Full Load	Dimensions Inches (WxDxH)	Approx. Weight LB. (unpacked)	Floor Loading Lb./Sq.ft (Concentrated Loading)
kVA	kW	VAC	Input Filter	Input Xformer	Nom	Max	Nom	Max						
65	52	208	NO	NO	184	229	180	226	175	141	14,390	34x32x68	1,900	251
65	52	208	YES	NO	170	213	180	226	175	141	15,015	34x32x68	1,950	258
65	52	208	NO	YES	187	233	180	226	175	141	17,555	34x32x68	2,400	318
65	52	208	YES	YES	173	216	180	226	175	141	18,200	34x32x68	2,450	324
80	64	208	NO	NO	226	282	222	278	175	174	17,710	34x32x68	2,100	278
80	64	208	YES	NO	209	262	222	278	175	174	18,480	34x32x68	2,150	285
80	64	208	NO	YES	230	287	222	278	175	174	21,600	34x32x68	2,630	348
80	64	208	YES	YES	213	266	222	278	175	174	22,395	34x32x68	2,680	355
100	80	208	NO	NO	282	353	278	347	250	217	22,140	48x33x79	2,900	264
100	80	208	YES	NO	262	327	278	347	250	217	23,100	48x33x79	2,950	268
100	80	208	NO	YES	287	359	278	347	250	217	27,005	48x33x79	3,270	297
100	80	208	YES	YES	266	333	278	347	250	217	27,995	48x33x79	3,320	302
125	100	208	NO	NO	353	441	347	434	250	271	27,675	48x33x79	3,050	277
125	100	208	YES	NO	327	409	347	434	250	271	28,875	48x33x79	3,100	282
125	100	208	NO	YES	359	449	347	434	250	271	33,755	48x33x79	3,450	314
125	100	208	YES	YES	333	416	347	434	250	271	34,995	48x33x79	3,500	318
150	120	208	NO	NO	424	530	416	520	350	326	33,200	56x33x79	3,320	259
150	120	208	YES	NO	393	491	416	520	350	326	34,650	56x33x79	3,450	269
150	120	208	NO	YES	431	538	416	520	350	326	40,500	56x33x79	4,020	313
150	120	208	YES	YES	399	499	416	520	350	326	42,000	56x33x79	4,150	323
225	180	208	NO	NO	635	794	625	781	500	488	49,800	56x33x79	3,870	302
225	180	208	YES	NO	589	736	625	781	500	488	52,000	56x33x79	4,000	312
225	180	208	NO	YES	646	807	625	781	500	488	60,750	56x33x79	4,510	351
225	180	208	YES	YES	599	748	625	781	500	488	63,000	56x33x79	4,640	362
<b>Applicable Notes:</b>			13		1,4,8,9,11,12		2,3,5,7,8,9,11,12		6	6,8,9,11,12		11		



## Series 600T Single Module Systems 480 Volt Input

UPS Rating		AC Output Voltage	Options		Rectifier AC Input Current		Inverter Or Bypass AC Output Current		Required Battery Disconnect Rating Amperes	Maximum Battery Current At End Of Discharge Amperes	Maximum Heat Dissipation BTU/Hr Full Load	Dimensions Inches (WxDxH)	Approx. Weight LB. (unpacked)	Floor Loading Lb./Sq.ft (Concentrated Loading)
kVA	kW	VAC	Input Filter	Input Xformer	Nom	Max	Nom	Max						
65	52	480	NO	NO	78	98	78	98	150	140	11,330	34x32x68	1,500	281
65	52	480	YES	NO	73	91	78	98	150	140	11,935	34x32x68	1,550	291
65	52	480	NO	YES	80	99	78	98	150	140	14,390	34x32x68	2,200	413
65	52	480	YES	YES	74	92	78	98	150	140	15,015	34x32x68	2,250	422
65	52	208	NO	NO	79	98	180	226	150	141	12,340	34x32x68	1,700	319
65	52	208	YES	NO	73	91	180	226	150	141	12,950	34x32x68	1,750	328
65	52	208	NO	YES	80	100	180	226	150	141	15,435	34x32x68	2,400	450
65	52	208	YES	YES	74	93	180	226	150	141	16,065	34x32x68	2,450	459
80	64	480	NO	NO	96	120	96	120	175	173	13,945	34x32x68	1,700	319
80	64	480	YES	NO	89	112	96	120	175	173	14,685	34x32x68	1,750	328
80	64	480	NO	YES	98	122	96	120	175	173	17,710	34x32x68	2,430	456
80	64	480	YES	YES	91	113	96	120	175	173	18,480	34x32x68	2,480	465
80	64	208	NO	NO	97	121	222	278	175	174	15,185	34x32x68	1,950	366
80	64	208	YES	NO	90	112	222	278	175	174	15,940	34x32x68	2,000	375
80	64	208	NO	YES	98	123	222	278	175	174	18,995	34x32x68	2,680	503
80	64	208	YES	YES	91	114	222	278	175	174	19,770	34x32x68	2,730	512
100	80	480	NO	NO	120	151	120	150	225	216	17,425	48x33x79	2,300	209
100	80	480	YES	NO	112	140	120	150	225	216	18,360	48x33x79	2,370	215
100	80	480	NO	YES	122	153	120	150	225	216	22,140	48x33x79	3,075	280
100	80	480	YES	YES	113	142	120	150	225	216	23,100	48x33x79	3,145	286
100	80	208	NO	NO	121	151	278	347	225	217	18,980	48x33x79	2,600	236
100	80	208	YES	NO	112	140	278	347	225	217	19,920	48x33x79	2,670	243
100	80	208	NO	YES	123	154	278	347	225	217	23,745	48x33x79	3,375	307
100	80	208	YES	YES	114	143	278	347	225	217	24,715	48x33x79	3,445	313
125	100	480	NO	NO	151	188	150	188	250	270	21,785	48x33x79	2,400	218
125	100	480	YES	NO	140	174	150	188	250	270	22,950	48x33x79	2,470	225
125	100	480	NO	YES	153	191	150	188	250	270	27,675	48x33x79	3,200	291
125	100	480	YES	YES	142	177	150	188	250	270	27,675	48x33x79	3,270	297
125	100	208	NO	NO	151	189	347	434	250	271	23,725	48x33x79	2,700	245
125	100	208	YES	NO	140	175	347	434	250	271	23,725	48x33x79	2,770	252
125	100	208	NO	YES	154	192	347	434	250	271	29,680	48x33x79	3,500	318
125	100	208	YES	YES	143	178	347	434	250	271	29,680	48x33x79	3,570	325
150	120	480	NO	NO	181	226	180	226	300	324	26,140	48x33x79	2,650	241
150	120	480	YES	NO	167	209	180	226	300	324	27,540	48x33x79	2,780	253
150	120	480	NO	YES	184	229	180	226	300	324	33,210	48x33x79	3,550	323
150	120	480	YES	YES	170	213	180	226	300	324	34,650	48x33x79	3,680	335
150	120	208	NO	NO	182	227	416	520	300	326	28,475	56x33x79	3,050	238
150	120	208	YES	NO	168	210	416	520	300	326	29,885	56x33x79	3,180	248
150	120	208	NO	YES	185	231	416	520	300	326	35,615	56x33x79	3,950	308
150	120	208	YES	YES	171	214	416	520	300	326	37,070	56x33x79	4,080	318
225	180	480	NO	NO	271	339	271	338	500	486	39,215	48x33x79	2,990	272
225	180	480	YES	NO	251	314	271	338	500	486	41,305	48x33x79	3,120	284
225	180	480	NO	YES	275	344	271	338	500	486	49,810	48x33x79	4,190	381
225	180	480	YES	YES	255	319	271	338	500	486	41,305	48x33x79	4,320	393
225	180	208	NO	NO	272	341	625	781	500	488	42,710	56x33x79	3,475	271
225	180	208	YES	NO	253	316	625	781	500	488	44,825	56x33x79	3,605	281
225	180	208	NO	YES	277	346	625	781	500	488	53,420	56x33x79	4,675	364
225	180	208	YES	YES	257	321	625	781	500	488	55,605	56x33x79	4,805	374
Applicable Notes:			13		1,4,8,9,11,12		2,3,5,7,8,9,11,12		6	6,8,9,11,12		11		

## Series 600T Single Module Systems 600 Volt Input

UPS Rating		AC Output Voltage	Options		Rectifier AC Input Current		Inverter Or Bypass AC Output Current		Required Battery Disconnect	Maximum Battery Current At End Of Discharge	Maximum Heat Dissipation BTU/Hr Full Load	Dimensions Inches (WxDxH)	Approx. Weight LB. (unpacked)	Floor Loading Lb./Sq.ft (Concentrated Loading)
kVA	kW	VAC	Input Filter	Input Xformer	Nom	Max	Nom	Max	Rating Amperes	Amperes				
65	52	600	NO	NO	63	79	63	78	150	140	12,340	34x32x68	1,600	300
65	52	600	YES	NO	58	73	63	78	150	140	12,950	34x32x68	1,650	309
65	52	600	NO	YES	64	80	63	78	150	140	15,435	34x32x68	2,200	413
65	52	600	YES	YES	59	74	63	78	150	140	16,065	34x32x68	2,250	422
65	52	208	NO	NO	63	79	180	226	150	141	13,355	34x32x68	1,800	338
65	52	208	YES	NO	59	73	180	226	150	141	13,975	34x32x68	1,850	347
65	52	208	NO	YES	64	80	180	226	150	141	16,490	34x32x68	2,400	450
65	52	208	YES	YES	60	75	180	226	150	141	17,125	34x32x68	2,450	459
80	64	600	NO	NO	77	97	77	96	175	173	15,185	34x32x68	1,800	338
80	64	600	YES	NO	72	90	77	96	175	173	15,940	34x32x68	1,850	347
80	64	600	NO	YES	79	98	77	96	175	173	18,995	34x32x68	2,430	456
80	64	600	YES	YES	73	91	77	96	175	173	19,770	34x32x68	2,480	465
80	64	208	NO	NO	78	97	222	278	175	174	16,445	34x32x68	2,050	384
80	64	208	YES	NO	72	90	222	278	175	174	17,200	34x32x68	2,100	394
80	64	208	NO	YES	79	99	222	278	175	174	20,290	34x32x68	2,680	503
80	64	208	YES	YES	73	92	222	278	175	174	21,075	34x32x68	2,730	512
100	80	600	NO	NO	97	121	96	120	225	216	18,980	48x33x79	2,450	223
100	80	600	YES	NO	90	112	96	120	225	216	18,920	48x33x79	2,520	229
100	80	600	NO	YES	98	123	96	120	225	216	23,745	48x33x79	3,075	280
100	80	600	YES	YES	91	114	96	120	225	216	24,715	48x33x79	3,145	286
100	80	208	NO	NO	97	122	278	347	225	217	20,550	48x33x79	2,750	250
100	80	208	YES	NO	90	113	278	347	225	217	21,500	48x33x79	2,820	256
100	80	208	NO	YES	99	124	278	347	225	217	25,265	48x33x79	3,375	307
100	80	208	YES	YES	92	115	278	347	225	217	26,345	48x33x79	3,445	313
125	100	600	NO	NO	121	151	120	150	250	270	23,725	48x33x79	2,600	236
125	100	600	YES	NO	112	140	120	150	250	270	24,900	48x33x79	2,670	243
125	100	600	NO	YES	123	154	120	150	250	270	29,680	48x33x79	3,200	291
125	100	600	YES	YES	114	143	120	150	250	270	30,895	48x33x79	3,270	297
125	100	208	NO	NO	122	152	347	434	250	271	25,690	48x33x79	2,900	264
125	100	208	YES	NO	113	141	347	434	250	271	26,875	48x33x79	2,970	270
125	100	208	NO	YES	124	155	347	434	250	271	31,705	48x33x79	3,500	318
125	100	208	YES	YES	115	143	347	434	250	271	32,930	48x33x79	3,570	325
150	120	600	NO	NO	145	182	144	180	300	324	28,480	48x33x79	2,920	265
150	120	600	YES	NO	135	168	144	180	300	324	29,880	48x33x79	3,050	277
150	120	600	NO	YES	148	185	144	180	300	324	35,615	48x33x79	3,570	325
150	120	600	YES	YES	137	171	144	180	300	324	37,070	48x33x79	3,700	336
150	120	208	NO	NO	146	183	416	520	300	326	30,825	56x33x79	3,270	255
150	120	208	YES	NO	135	169	416	520	300	326	32,250	56x33x79	3,400	265
150	120	208	NO	YES	148	186	416	520	300	326	38,045	56x33x79	3,920	305
150	120	208	YES	YES	138	172	416	520	300	326	39,520	56x33x79	4,050	316
225	180	600	NO	NO	218	272	217	271	500	486	42,710	48x33x79	3,260	296
225	180	600	YES	NO	202	253	217	271	500	486	44,825	48x33x79	3,390	308
225	180	600	NO	YES	221	277	217	271	500	486	53,420	48x33x79	4,210	383
225	180	600	YES	YES	205	257	217	271	500	486	55,605	48x33x79	4,340	395
225	180	208	NO	NO	219	274	625	781	500	488	46,240	56x33x79	3,660	285
225	180	208	YES	NO	203	254	625	781	500	488	48,380	56x33x79	3,790	295
225	180	208	NO	YES	223	278	625	781	500	488	57,070	56x33x79	4,610	359
225	180	208	YES	YES	206	258	625	781	500	488	59,280	56x33x79	4,740	369
<b>Applicable Notes:</b>			13		1,4,8, 9,11,12		2,3,5,7,8, 9,11,12		6	6,8,9, 11,12		11		



# Series 600T™ UPS

## INSTALLATION MANUAL

### The Company Behind the Products

With over a million installations around the globe, Liebert is the world leader in computer protection systems. Since its founding in 1965, Liebert has developed a complete range of support and protection systems for sensitive electronics:

- Environmental systems—close-control air conditioning from 1 to 60 tons
- Power conditioning and UPS with power ranges from 300 VA to more than 1000 kVA
- Integrated systems that provide both environmental and power protection in a single, flexible package
- Monitoring and control—from systems of any size or location, on-site or remote
- Service and support through more than 100 service centers around the world and a 24/7 Customer Response Center

While every precaution has been taken to ensure the accuracy and completeness of this literature, Liebert Corporation assumes no responsibility and disclaims all liability for damages resulting from use of this information or for any errors or omissions.

© 2000 Liebert Corporation  
All rights reserved throughout the world.  
Specifications subject to change without notice.

® Liebert and the Liebert logo are registered trademarks of Liebert Corporation. All names referred to are trademarks or registered trademarks of their respective owners.

SL-30545 (2/00)

### Technical Support

#### United States

1050 Dearborn Drive  
P.O. Box 29186  
Columbus, OH 43229

#### Single-Phase UPS

800-543-2378

#### Outside the United States

614-841-6598

#### 3-Phase UPS

800-543-2378

#### Environmental Control

800-543-2778

#### Italy

Via Leonardo Da Vinci 8  
Zona Industriale Tognana  
35028 Piove Di Sacco (PD)  
+39 049 9719 111  
FAX: +39 049 5841 257

#### Asia

23F, Allied Kajima Bldg.  
138 Gloucester Road  
Wanchai  
Hong Kong  
+852 2 572 2201  
FAX: +852 2 831 0114

#### Web Site

[www.liebert.com](http://www.liebert.com)

#### E-mail

[UPStech@liebert.com](mailto:UPStech@liebert.com)