



POWER PROTECTION

# Series 600T™ UPS

## Multi-Module Three Phase 500 kVA to 750 kVA, 60 Hz

# Installation Manual

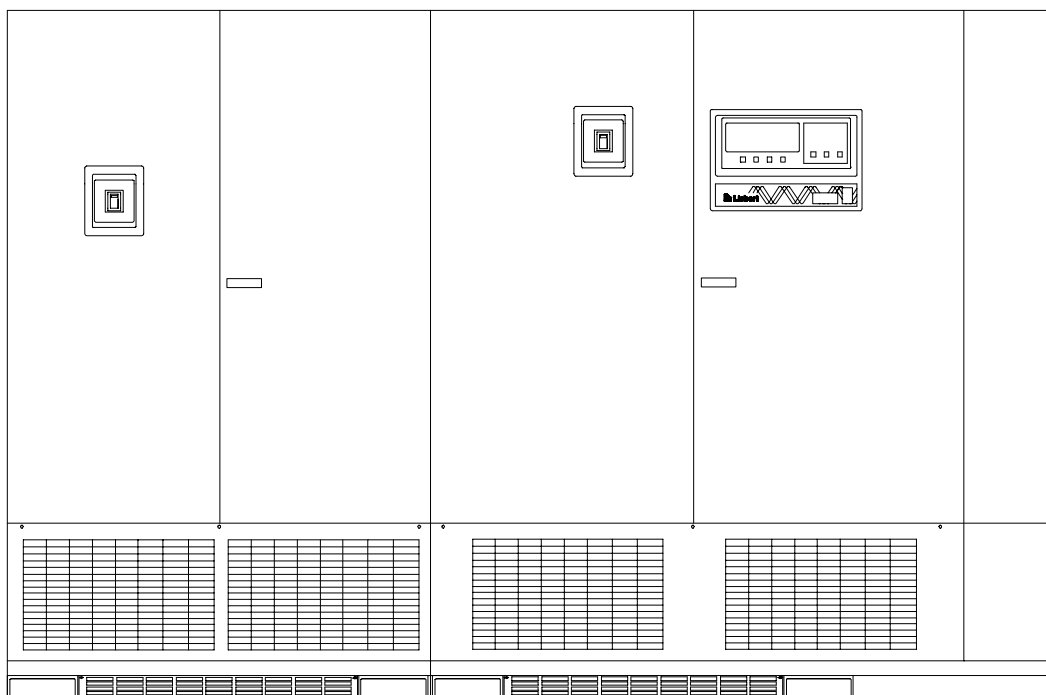

---

The following **WARNING** applies to all battery cabinets supplied with UPS systems:

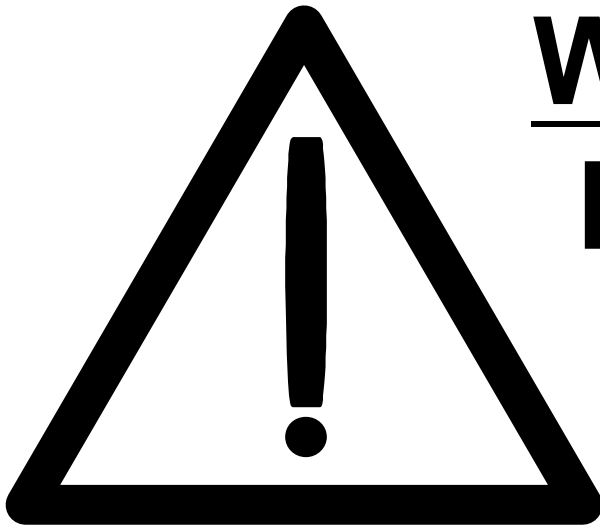

# **WARNING** **HAZARD**

**INTERNAL BATTERY STRAPPING MUST BE VERIFIED BY MANUFACTURER PRIOR TO MOVING A BATTERY CABINET.**

**Battery cabinets contain non-spillable batteries.**

**Keep units upright.**

**Do not stack.**

**Do not tilt.**

**Failure to heed this warning could result in smoke, fire or electric hazard. Call 1-800-LIEBERT prior to moving battery cabinets.**

---

---

# Table of Contents

1.0	SAFETY PRECAUTIONS .....	3
2.0	INSTALLATION CONSIDERATIONS .....	4
2.1	Types of System Control Cabinets .....	6
3.0	UNLOADING AND HANDLING .....	7
4.0	INSPECTIONS	
4.1	External Inspections .....	8
4.2	Internal Inspections .....	8
5.0	EQUIPMENT LOCATION .....	9
6.0	BATTERY INSTALLATION	
6.1	Battery Safety Precautions .....	10
6.2	Matching Battery Cabinets .....	13
6.3	Non-Standard Batteries .....	13
7.0	CONFIGURING YOUR NEUTRAL AND GROUND CONNECTIONS	
7.1	Preferred Grounding Configuration, Wye-Connected Service .....	15
7.2	Grounding Configuration, Delta Source .....	16
7.3	Preferred Grounding Configuration with Power-Tie Switchgear .....	17
7.4	Grounding Configurations, Battery Systems .....	18
8.0	WIRING CONSIDERATIONS	
8.1	Power Wiring .....	20
8.2	Control Wiring .....	21
8.3	Battery Wiring .....	22
9.0	WIRING CONNECTIONS .....	25
10.0	WIRING INSPECTION	
	Table 1 Power Wiring Terminals - Factory Supplied .....	27
	Table 2 Torque Specifications .....	27
	Table 3 Table 310-16 .....	28
11.0	INSTALLATION DRAWINGS .....	29
12.0	APPENDIX A - SITE PLANNING DATA	
	Table 4 Series 600T Multi-Module Systems, 500-750 kVA - 480 Volt Input .....	81
	Table 5 Series 600T Multi-Module Systems, 500-750 kVA - 600 Volt Input .....	82
13.0	APPENDIX B - FIELD SUPPLIED LUGS	
	Table 6 One-Hole Lugs .....	83

---

---

---

## List of Figures

Figure 1	UPS Multi-Module Unit Block Diagram . . . . .	5
Figure 2	System Control Cabinets . . . . .	6
Figure 3	Preferred Grounding Configuration, 480 or 600 VAC Input and Output . . . . .	15
Figure 4	Grounding Configuration with Ungrounded Delta Source Input . . . . .	16
Figure 5	Preferred Grounding Configuration, Power-Tie Systems . . . . .	17
Figure 6	Battery Cabinet Grounding Configuration . . . . .	18
Figure 7	Typical Multi-Module Configurations . . . . .	23
Figure 8	Outline Drawing, 500 kVA Multi-Module UPS, 6-Pulse Rectifier . . . . .	29
Figure 9	Outline Drawing, 500 kVA Multi-Module UPS, 12-Pulse Rectifier . . . . .	30
Figure 10	Outline Drawing, 625-750 kVA Multi-Module UPS, 6-Pulse Rectifier . . . . .	31
Figure 11	Outline Drawing, 625-750 kVA Multi-Module UPS, 12-Pulse Rectifier . . . . .	32
Figure 12	Outline Drawing, System Control Cabinet (SCCT), 200-1200 Amps . . . . .	33
Figure 13	Outline Drawing, System Control Cabinet (SCCT), 1600-2500 Amps . . . . .	34
Figure 14	Outline Drawing, System Control Cabinet (SCCT), 3000 Amps . . . . .	35
Figure 15	Outline Drawing, System Control Cabinet (SCCT) 4000 Amps . . . . .	36
Figure 16	Battery Power Pack, Size A . . . . .	37
Figure 17	Battery Power Pack, Size B . . . . .	38
Figure 18	Battery Power Pack, Three-Pack System . . . . .	39
Figure 19	Base Mounting Patterns, 500 kVA Module, 12-Pulse Rectifier . . . . .	40
Figure 20	Base Mounting Patterns, 625-750 kVA Module, 6-Pulse . . . . .	41
Figure 21	Base Mounting Patterns, 625-750 kVA Module, 12-Pulse Rectifier . . . . .	42
Figure 22	Base Mounting Patterns, System Control Cabinets (SCCT) 200-1200 Amps . . . . .	43
Figure 23	Base Mounting Patterns, System Control Cabinet (SCCT), 1600-2500 Amps . . . . .	44
Figure 24	Base Mounting Patterns (SCCT), 3000 Amps . . . . .	45
Figure 25	Base Mounting Patterns (SCCT), 4000 Amps . . . . .	46
Figure 26	Shipping Split Detail, 500 kVA Multi-Module UPS, 12-Pulse Rectifier . . . . .	47
Figure 27	Shipping Split Detail, 625-750 kVA Multi-Module UPS, 6-Pulse Rectifier . . . . .	48
Figure 28	Shipping Split Detail, 625-750 kVA Multi-Module UPS, 12-Pulse Rectifier . . . . .	49
Figure 29	Terminal Details, 500 kVA Module, 6-Pulse Rectifier . . . . .	50
Figure 30	Terminal Details, 500 kVA Module, 12-Pulse Rectifier . . . . .	51
Figure 31	Terminal Details, 625 & 750 kVA Modules, 6-Pulse and 12-Pulse . . . . .	52
Figure 32	Terminal Details, 750 kVA with Input Bus Bars . . . . .	53
Figure 33	Control Wiring, External Interconnections, Standard UPS Module . . . . .	54
Figure 34	Control Connection Location, 500 kVA Modules . . . . .	55
Figure 35	Control Connection Location Diagram, 625 & 750 kVA Modules . . . . .	56
Figure 36	Control Connection Location Diagram, SCCC & SCCI . . . . .	57
Figure 37	Control Connection Location Diagram, SCCT . . . . .	58
Figure 38	Control Wire List, External Interconnections, Standard UPS Module . . . . .	59
Figure 39	Control Wire List, External Interconnections, System Control Cabinet, Part 1 of 3 . . . . .	60
Figure 40	Control Wire List, External Interconnections, Standard SCC, Part 2 of 3 . . . . .	61
Figure 41	Control Wire List, External Interconnections, Standard SCC, Part 3 of 3 . . . . .	62
Figure 42	Control Wire List, External Interconnections, Alarm Status Contacts . . . . .	63
Figure 43	Option Wiring, Maintenance Bypass Interlock . . . . .	64
Figure 44	Option Wiring, Remote Status Panel Interface . . . . .	65
Figure 45	Option Wiring, Internal Modem . . . . .	66
Figure 46	Option Wiring, Customer Alarm Interface, SCC with Momentary-Duty Static Switch . . . . .	67
Figure 47	Option Wiring, Customer Alarm Interface, SCC with Continuous-Duty Static Switch . . . . .	68

---

Figure 48	Option Wiring, Battery Temperature Sensor .....	69
Figure 49	Option Wiring, SNMP Interface .....	70
Figure 50	External Interconnections, Module 1/SCC, Cable Groups 21 and 22 .....	71
Figure 51	External Interconnections, Module 2/SCC, Cable Groups 21 and 22 .....	72
Figure 52	Wiring Configurations, UPS Video Display Terminal .....	73
Figure 53	Module Battery Disconnect, 600-1200 Amps, without Input Isolation Transformer .....	74
Figure 54	Module Battery Disconnect, 300-1200 Amps, with Input Isolation Transformer .....	75
Figure 55	Remote Status Panel, Surface Mount .....	76
Figure 56	Circuit Breaker Schedule, Multi-Module UPS, 300-750 kVA .....	77
Figure 57	Circuit Breaker Schedule, Merlin-Gerin Breakers, SCCT, 200-4000 Amps .....	78
Figure 58	Circuit Breaker Schedule, General Electric Breakers, SCCT, 200-4000 Amps .....	79

---

## IMPORTANT SAFETY INSTRUCTIONS

---

### Save These Instructions.

This manual contains important instructions that should be followed during installation of your Series 600T UPS and batteries.



### **WARNING**

**EXERCISE EXTREME CARE WHEN HANDLING UPS CABINETS TO AVOID EQUIPMENT DAMAGE OR INJURY TO PERSONNEL. THE UPS MODULE WEIGHT RANGES UP TO 12,000 POUNDS (5,455 KG), INCLUDING INPUT TRANSFORMER. THE BATTERY CABINETS WEIGH BETWEEN 3000 POUNDS (1364 KG) AND 4900 POUNDS (2227 KG).**

**LOCATE CENTER OF GRAVITY SYMBOLS BEFORE HANDLING EACH CABINET. TEST LIFT AND BALANCE THE CABINETS BEFORE TRANSPORTING. MAINTAIN MINIMUM TILT FROM VERTICAL AT ALL TIMES.**

**SLOTS AT THE BASE OF THE MODULES AND BATTERY CABINETS ARE INTENDED FOR FORKLIFT USE. BASE SLOTS WILL SUPPORT THE UNIT ONLY IF THE FORKS ARE COMPLETELY BENEATH THE UNIT.**

**SYSTEM CONTROL CABINETS (SCC'S) HAVE HOLES INTENDED FOR RIGGING BARS OR CHAINS. PREVENT CHAINS OR CABLES FROM CONTACTING CABINET BY USING SPREADER BAR AND ADEQUATE PADDING.**

**FOLLOW ALL BATTERY SAFETY PRECAUTIONS WHEN INSTALLING, CHARGING, OR SERVICING BATTERIES. IN ADDITION TO THE HAZARD OF ELECTRIC SHOCK, GAS PRODUCED BY BATTERIES CAN BE EXPLOSIVE AND SULFURIC ACID CAN CAUSE SEVERE BURNS.**

**IN CASE OF FIRE INVOLVING ELECTRICAL EQUIPMENT, ONLY CARBON DIOXIDE FIRE EXTINGUISHERS, OR THOSE APPROVED FOR USE IN ELECTRICAL FIRE FIGHTING, SHOULD BE USED.**

**EXTREME CAUTION IS REQUIRED WHEN PERFORMING MAINTENANCE.**

**BE CONSTANTLY AWARE THAT THE UPS SYSTEM CONTAINS HIGH DC AS WELL AS AC VOLTAGES.**

**CHECK FOR VOLTAGE WITH BOTH AC AND DC VOLTMETERS PRIOR TO MAKING CONTACT.**



**WARNING**

**LOCATE CENTER OF GRAVITY SYMBOLS AND DETERMINE UNIT WEIGHT BEFORE HANDLING CABINET.**



If you require assistance for any reason, call the toll-free Liebert Global Services number; 1-800-543-2378. For LGS to assist you expediently, please have the following information available:

Part Numbers: \_\_\_\_\_

Serial Numbers: \_\_\_\_\_

kVA Rating: \_\_\_\_\_

Date Purchased: \_\_\_\_\_

Date Installed: \_\_\_\_\_

Location: \_\_\_\_\_

Input Voltage: \_\_\_\_\_

Output Voltage: \_\_\_\_\_

Battery Reserve Time: \_\_\_\_\_



---

## 1.0 SAFETY PRECAUTIONS

---

Read this manual thoroughly, paying special attention to the sections that apply to you, before working with the UPS. **Retain this manual for use by installing personnel.**

Under typical operation and with all UPS doors closed, only normal safety precautions are necessary. The area around the UPS system should be kept free from puddles of water, excess moisture, or debris.

Special safety precautions are required for procedures involving handling, installation, and maintenance of the UPS system or the battery. Observe all safety precautions in this manual before handling or installing the UPS system. Observe all precautions in the **Operation and Maintenance Manual**, before as well as during performance of all maintenance procedures. Observe all battery safety precautions before working on or near the battery.

**This equipment contains several circuits that are energized with high voltage.** Only test equipment designated for troubleshooting should be used. This is particularly true for oscilloscopes. Always check with an AC and DC voltmeter to ensure safety before making contact or using tools. Even when the power is turned Off, dangerously high potentials may exist at the capacitor banks and at the batteries.

**ONLY qualified service personnel should perform maintenance on the UPS system.** When performing maintenance with any part of the equipment under power, service personnel and test equipment should be standing on rubber mats. The service personnel should wear insulating shoes for isolation from direct contact with the floor (earth ground).

Unless all power is removed from the equipment, one person should never work alone. A second person should be standing by to assist and summon help in case an accident should occur.

Four types of messages are used throughout the manual to stress important text. Carefully read the text below each Danger, Warning, Caution, and Note and use professional skills and prudent care when performing the actions described by that text.

A **Danger** signals immediate hazards resulting in severe personal injury or death. For example:



### **DANGER**

**A DANGER SIGNALS IMMEDIATE HAZARDS WHICH WILL RESULT IN SEVERE PERSONAL INJURY OR DEATH.**

A **Warning** signals the presence of a possible serious, life-threatening condition. For example:



### **WARNING**

**LETHAL VOLTAGES MAY BE PRESENT WITHIN THIS UNIT EVEN WHEN IT IS APPARENTLY NOT OPERATING. OBSERVE ALL CAUTIONS AND WARNINGS IN THIS MANUAL. FAILURE TO DO SO COULD RESULT IN SERIOUS INJURY OR DEATH. DO NOT WORK ON OR OPERATE THIS EQUIPMENT UNLESS YOU ARE FULLY QUALIFIED TO DO SO!! NEVER WORK ALONE.**

A **Caution** indicates a condition that could seriously damage equipment and possibly injure personnel. For example:



### **CAUTION**

**Extreme care is necessary when removing shoring braces. Do not strike the cabinet with hammers or other tools.**

A **Note** emphasizes important text. If the note is not followed, equipment could be damaged or may not operate properly. For example:



### **NOTE**

*If the UPS system has a blown fuse, the cause should be determined before you replace the fuse. Contact Liebert Global Services.*

---

## 2.0 INSTALLATION CONSIDERATIONS

---

Install your Series 600T UPS in accordance with the submittal drawing package and the following procedures.

A Liebert authorized representative must perform the initial system check-out and start-up to ensure proper system operation. Equipment warranties will be voided unless system start-up is performed by a Liebert authorized representative. Contact your local Liebert sales representative or Liebert Global Services at **1-800-543-2378** to arrange for system start-up.



### CAUTION

**Read this manual thoroughly before attempting to wire or operate the unit. Improper installation is the most significant cause of UPS start-up problems.**

**Do not install this equipment near gas or electric heaters. It is preferable to install the UPS in a restricted location to prevent access by unauthorized personnel.**

1. Proper planning will speed unloading, location, and connection of the UPS. **Refer to Figure 8 through Figure 58 and Appendix A - Site Planning Data.**
2. Refer to information later in this manual regarding the optional Battery Cabinets and Transformer Cabinets. **Observe all battery safety precautions when working on or near the battery.**
3. Use the shortest output distribution cable runs possible, consistent with logical equipment arrangements and with allowances for future additions if planned.
4. Recommended ambient operating temperature is 25°C (77°F). Relative humidity must be less than 95%, non-condensing. Note that room ventilation is necessary, but air conditioning may not be required. Maximum ambient operating temperature is 40°C (104°F) without derating. The batteries should not exceed 25°C (77°F). At elevations above 4,000 feet (1219 meters) derating may be required (consult your Liebert sales representative).
5. Even though your Liebert UPS unit is at least 93% efficient, the heat output is substantial. For more specific information, see **Appendix A - Site Planning Data**. Be sure environmental conditioning systems can accommodate this BTU load, even during utility outages.
6. The routing (inside the facility) to the installation site, as well as the floor at the final equipment location, must be capable of supporting the cabinet weight and the weight of any moving equipment. The modules weigh up to 12,000 pounds. The battery cabinets weigh between 3000 and 4900 pounds. The System Control Cabinets weigh between 1000 and 2550 pounds. Refer to **Appendix A - Site Planning Data**.
7. Plan the routing to ensure that the unit can move through all aisleways, doorways, and around corners without risking damage. If the modules and batteries must be moved by elevator, check the size of the door openings and the weight-carrying capacity of the elevator.



### WARNING

**LOCATE CENTER OF GRAVITY SYMBOLS AND DETERMINE UNIT WEIGHT BEFORE HANDLING CABINET.**



Figure 1 UPS Multi-Module Unit Block Diagram

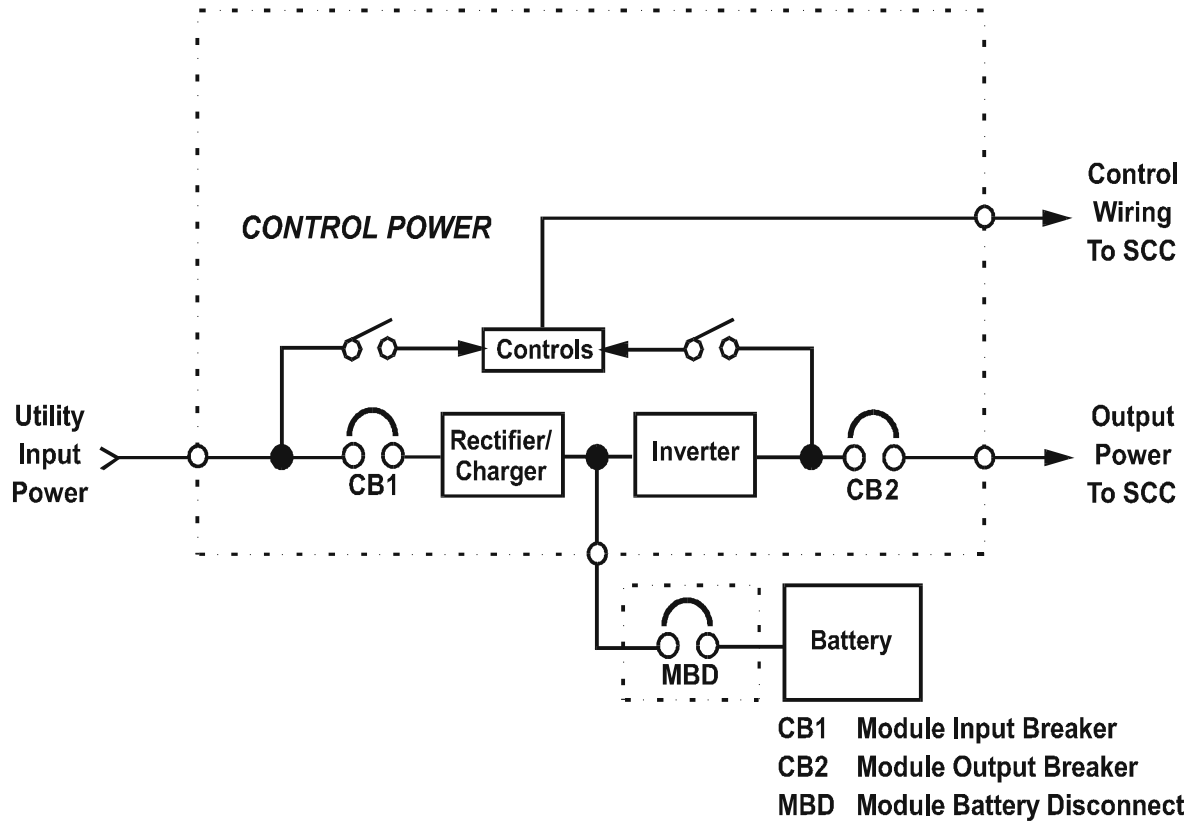

**Figure 2 System Control Cabinets**

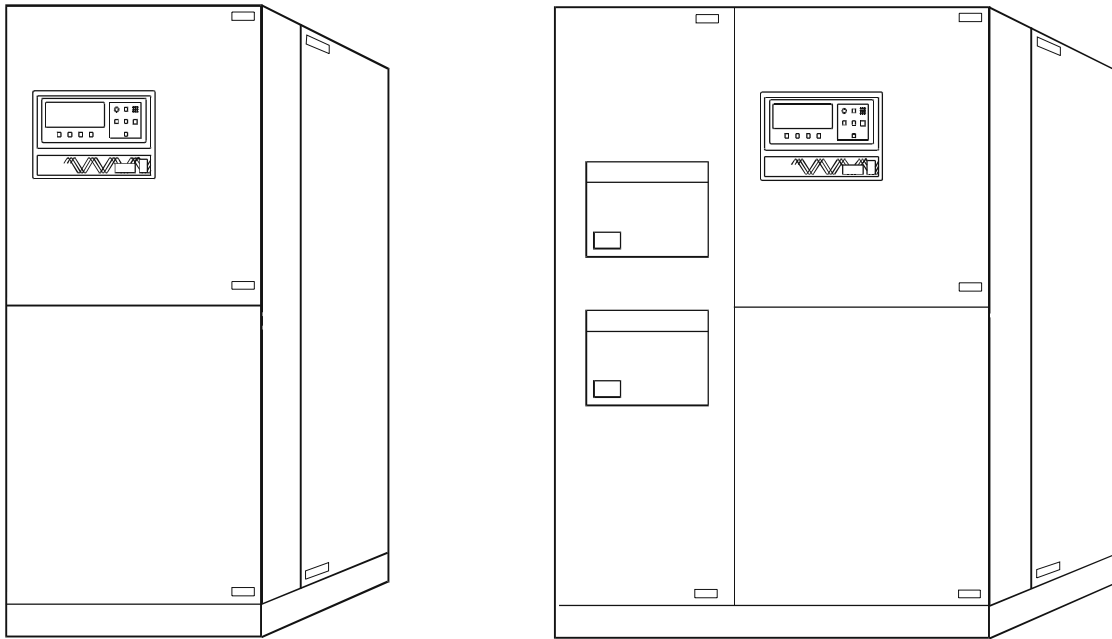

SCCT Dimensions		
Amp	WxD	Weight
Ratings	(Inches)	(lbs.)
200-1200	37x37	1000
1600	62x48	1525
2000-2500	62x48	2850
3000	62x48	3100
4000	138x60	5850

## 2.1 Types of System Control Cabinets

1. **SCCT** is a stand-alone cabinet containing system control logic for up to six UPS modules, static bypass switch, manually operated disconnects for the static bypass switch, and two motor-operated system breakers. The SCCT is painted the same color as the Liebert UPS, but does not match the sheet metal style of the UPS.
2. **SCCI** has the system control logic, circuit breakers and static bypass switch integrated into a switchboard cabinet manufactured by others.
3. **SCCC** is an integrated configuration like the SCCI with the static bypass switch rated for continuous duty.

---

## 3.0 UNLOADING AND HANDLING

---

The UPS module is shipped in one cabinet to allow easy handling at the site. Because the weight distribution in the cabinet is uneven, use extreme care during handling and transport. Your installation may also include Battery Cabinets and a System Control Cabinet.



### **WARNING**

**EXERCISE EXTREME CARE WHEN HANDLING UPS CABINETS TO AVOID EQUIPMENT DAMAGE OR INJURY TO PERSONNEL. THE UPS MODULE WEIGHS UP TO 12,000 POUNDS. BATTERY CABINETS WEIGH BETWEEN 3100 AND 4900 POUNDS.**

**LOCATE CENTER OF GRAVITY SYMBOLS BEFORE HANDLING CABINET. TEST LIFT AND BALANCE THE CABINET BEFORE TRANSPORTING. MAINTAIN MINIMUM TILT FROM VERTICAL AT ALL TIMES.**

**SLOTS AT THE BASE OF THE MODULES AND BATTERY CABINETS ARE INTENDED FOR FORKLIFT USE. BASE SLOTS WILL SUPPORT THE UNIT ONLY IF THE FORKS ARE COMPLETELY BENEATH THE UNIT.**

**SYSTEM CONTROL CABINETS (SCC'S) HAVE HOLES INTENDED FOR RIGGING BARS OR CHAINS. PREVENT CHAINS OR CABLES FROM CONTACTING CABINET BY USING SPREADER BAR AND ADEQUATE PADDING.**

To reduce the possibility of shipping damage, cabinets are shored with 2x4 bracing, secured with screw-type nails. This shoring must be carefully removed prior to unloading.



### **CAUTION**

**Extreme care is necessary when removing shoring braces. Do not strike cabinet with hammers or other tools.**

---

## 4.0 INSPECTIONS

---

### 4.1 External Inspections

1. While the UPS system is still on the truck, inspect the equipment and shipping container(s) for any signs of damage or mishandling. Do not attempt to install the system if damage is apparent. If any damage is noted, file a damage claim with the shipping agency within 24 hours and contact Liebert Global Services at 1-800-543-2378 to inform them of the damage claim and the condition of the equipment.
2. Locate the bag containing the keys for the front access door. The bag is attached to the cabinet.
3. Compare the contents of the shipment with the bill of lading. Report any missing items to the carrier and to Liebert Global Services immediately.
4. Check the nameplate on the cabinets to verify that the model numbers correspond with the one specified. Record the model numbers and serial numbers in the front of this installation manual. A record of this information is necessary should servicing become required.

### 4.2 Internal Inspections

1. Verify that all items have been received.
2. If spare parts were ordered, verify arrival.
3. Open doors and remove cabinet panels to check for shipping damage to internal components.
4. Check for loose connections or unsecured components in the cabinet(s).
5. Check for installation of circuit breaker line safety shields. There should be no exposed circuit breaker terminals when the cabinet doors are opened.
6. Check for any unsafe condition that may be a potential safety hazard.
7. UPS modules are shipped with internally mounted shipping brackets. The shipping brackets (painted orange) must be removed from the rear (remove rear panels).

---

## 5.0 EQUIPMENT LOCATION

---

1. Handle cabinet(s) in accordance with the **Section 1.0 Safety Precautions and 3.0 Unloading & Handling**. Use a suitable material handling device to move cabinet to its final location. **Exercise extreme care because of the uneven weight distribution.** Carefully lower the cabinet to the floor.
2. Verify that the UPS system is installed in a clean, cool and dry location.
3. Installation and serviceability will be easier if adequate access is provided on all sides of the equipment, but only front access is required.
  - a. Verify that there is adequate clearance to open cabinet doors. See drawings and local codes (4 feet is recommended).
  - b. Verify that there is adequate area in front of circuit breakers to perform maintenance. Check installation drawings for location of breakers. Check with local codes.
  - c. Verify that there is adequate clearance above all cabinets to allow exhaust air to flow without restriction (2 feet minimum, unobstructed).

---

## 6.0 BATTERY INSTALLATION

---

### 6.1 Battery Safety Precautions

Servicing of batteries should be performed or supervised by personnel knowledgeable of batteries and the required precautions. Keep unauthorized personnel away from batteries.

When replacing batteries, use the same number and type of batteries.



#### **CAUTION**

**Lead-acid batteries contain hazardous materials. Batteries must be handled, transported, and recycled or discarded in accordance with federal, state, and local regulations. Because lead is a toxic substance, lead-acid batteries should be recycled rather than discarded.**

**Do not open or mutilate the battery or batteries. Released electrolyte is harmful to the skin and eyes. It may be toxic. Do not dispose of battery or batteries in a fire. The battery may explode.**

**A battery can present a risk of electrical shock and high short circuit current. The following precautions should be observed when working on batteries:**

- 1. Remove watches, rings, or other metal objects.**
- 2. Use tools with insulated handles.**
- 3. Wear rubber gloves and boots.**
- 4. Do not lay tools or metal parts on top of batteries.**
- 5. Disconnect charging source prior to connecting or disconnecting battery terminals.**
- 6. Determine if battery is inadvertently grounded. If inadvertently grounded, remove source of ground. Contact with any part of a grounded battery can result in electrical shock. The likelihood of such shock will be reduced if such grounds are removed during installation and maintenance.**

**Lead-acid batteries can present a risk of fire because they generate hydrogen gas. The following procedures should be followed:**

- 1. DO NOT SMOKE when near batteries.**
- 2. DO NOT cause flame or spark in battery area.**
- 3. Discharge static electricity from body before touching batteries by first touching a grounded metal surface.**



---

## Battery Safety Precautions in French Per CSA Requirements

### Instructions Importantes Concernant La Sécurité

#### Conserver Ces Instructions



#### **ADVERTISSEMENT**

**DES PIÈCES SOUS ALIMENTATION SERONT LAISSÉES SANS PROTECTION DURANT CES PROCÉDURES D'ENTRETIEN. UN PERSONNEL QUALIFIÉ EST REQUIS POUR EFFECTUER CES TRAVAUX.**

**LES FUSIBLES A C.C. DE LA BATTERIE D'ACCUMULATEURS OPÈRENT EN TOUT TEMPS A LA TENSION NOMINALE. LA PRÉSENCE D'UN FUSIBLE A C.C. BRÛLE INDIQUE UN PROBLÈME SÉRIEUX. LE REMPLACEMENT DE CE FUSIBLE, SANS AVOIR DÉTERMINÉ LES RAISONS DE LA DÉFECTUOSITÉ, PEUT ENTRAÎNER DES BLESSURES OU DES DOMMAGES SÉRIEUX A L'ÉQUIPEMENT. POUR ASSISTANCE, APPELER LE DÉPARTEMENT DE SERVICE A LA CLIENTÈLE DE LIEBERT.**



#### **DANGER**

**Les accumulateurs plomb-acide contiennent de la matière comportant un certain risque. Les accumulateurs doivent être manipulés, transportés et recyclés ou éliminés en accord avec les lois fédérales, provinciales et locales. Parce que le plomb est une substance toxique, les accumulateurs plomb-acide devraient être recyclés plutôt qu'éliminés.**

**Il ne faut pas brûler le ou les accumulateurs. L'accumulateur pourrait alors exploser.**

**Il ne faut pas ouvrir ou endommager le ou les accumulateurs. L'électrolyte qui pourrait s'en échapper est dommageable pour la peau et les yeux.**

**Un accumulateur représente un risque de choc électrique et de haut courant de court-circuit. Lorsque des accumulateurs sont manipulés, les mesures préventives suivantes devraient être observées:**

- 1. Retirer toutes montres, bagues ou autres objets métalliques.**
- 2. Utiliser des outils avec manchon isolé.**
- 3. Porter des gants et des bottes de caoutchouc.**
- 4. Ne pas déposer les outils ou les pièces métalliques sur le dessus des accumulateurs.**
- 5. Interrompre la source de charge avant de raccorder ou de débrancher les bornes de la batterie d'accumulateurs.**
- 6. Déterminer si l'accumulateur est mis à la terre par erreur. Si oui, défaire cette mise à la terre. Tout contact avec un accumulateur mis à la terre peut se traduire en un choc électrique. La possibilité de tels chocs sera réduite si de telles mises à la terre sont débranchées pour la durée de l'installation ou de l'entretien.**

---

**Les accumulateurs plomb-acide présentent un risque d'incendie parce qu'ils génèrent des gaz à l'hydrogène. Les procédures suivantes devront être respectées.**

- 1. NE PAS FUMER** lorsque près des accumulateurs.
- 2. NE PAS produire de flammes ou d'étincelles** près des accumulateurs.
- 3. Décharger toute électricité statique présente sur votre corps avant de toucher un accumulateur en touchant d'abord une surface métallique mise à la terre.**



**DANGER**

**L'électrolyte est un acide sulfurique dilué qui est dangereux au contact de la peau et des yeux. Ce produit est corrosif et aussi conducteur électrique. Les procédures suivantes devront être observées:**

- 1. Porter toujours des vêtements protecteurs ainsi que des lunettes de protection pour les yeux.**
- 2. Si l'électrolyte entre en contact avec la peau, nettoyer immédiatement en rinçant avec de l'eau.**
- 3. Si l'électrolyte entre en contact avec les yeux, arroser immédiatement et généreusement avec de l'eau. Demander pour de l'aide médicale.**
- 4. Lorsque l'électrolyte est renversée, la surface affectée devrait être nettoyée en utilisant un agent neutralisant adéquat. Une pratique courante est d'utiliser un mélange d'approximativement une livre (500 grammes) de bicarbonate de soude dans approximativement un gallon (4 litres) d'eau. Le mélange de bicarbonate de soude devra être ajouté jusqu'à ce qu'il n'y ait plus apparence de réaction (mousse). Le liquide résiduel devra être nettoyé à l'eau et la surface concernée devra être asséchée.**

---

## 6.2 Matching Battery Cabinets

Two sizes of optional battery cabinets are available. Refer to **Figure 16** to **Figure 18**. The battery cabinet cells range from 90 to 150 Ampere-hours. The same model battery cabinet may be paralleled in multiple cabinet strings for additional capacity. Battery capacity (in minutes) at your installation will depend on cabinet model, number of cabinets, and amount of critical load on the UPS.

1. **Handling.** The Battery Cabinet weighs 3000 to 4900 pounds. Forklift slots are provided for easy handling.
2. **Cabinet Inspection.** Remove all panels and visually inspect the batteries, bus connections, and cabinet for any damage. **Exercise caution; voltage is present within the Battery Cabinet even before installation.** If there are signs of damage, do not proceed. Call Liebert Global Services at 1-800-543-2378.
3. **Battery Storage.** The batteries used in the Battery Cabinet have an excellent charge retaining characteristic. The batteries can be stored for up to six months without any appreciable deterioration. Self-discharge rate of the batteries is approximately 3% per month when the batteries are stored in temperatures of 15°C to 25°C (59°F to 77°F). If the Battery Cabinet is planned to be stored for longer than six months, contact Liebert Customer Service for recommended action.
4. **Installation.** The Battery Cabinet(s) can be located conveniently next to each UPS module. The front-access-only-design eliminates side and rear service clearance requirements.
  - **Environment.** Locate the Battery Cabinet in a clean, dry environment. Recommended temperature range for optimum performance and lifetime is 20°C (68°F) to 25°C (77°F).
  - **Service Clearance.** Allow front access to the Battery Cabinet at all times for maintenance and servicing. Electrical codes require that the Battery Cabinet be installed with no less than 3 feet (1 meter) of clearance at the front of the cabinet when operating. Side and rear panels do not require service clearance.
  - **Side Panels.** Remove protective side panels to connect cabinets together. Panels are retained at the bottom with three screws.
  - **Shield Plate.** If the Battery Cabinets are bolted to the side of the UPS module, the shield plate inside the Battery Cabinet should be on the side toward the UPS module for proper UPS airflow. Move the shield if required by your Battery Cabinet location.
  - **Cables.** Cables may be run between the cabinets through cutouts in the top of the cabinet, eliminating the need for external conduit runs. **Route cables before moving cabinets into final position for bolting together.** Remove top panels for access, if required. No top or bottom entry cables are required, except for remotely located cabinets which require conduits. Refer to **Figure 16** through **Figure 18**.
  - **Built-In Cabinets.** Matching Battery Cabinets are designed as a bolt-on section to the side of the UPS module cabinet. Use bolts (3/8"-16 x 1-1/4") to connect cabinet frames at posts, two places front and two places rear. Brackets are provided to make rear connections easier from inside the cabinet.

## 6.3 Non-Standard Batteries

When batteries other than a matching Battery Cabinet are used (not recommended), a remote battery disconnect switch with overcurrent protection is required per the National Electrical Code. Refer to **Figure 53** and **Figure 54**. Contact your Liebert sales representative regarding this option.

1. Install battery racks/cabinets and batteries per manufacturer's installation and maintenance instructions.
2. Verify battery area has adequate ventilation and battery operating temperature complies with manufacturer's specification.

If you have any questions concerning batteries, battery racks, or accessories, contact Liebert Global Services at 1-800-543-2378.

---

## 7.0 CONFIGURING YOUR NEUTRAL AND GROUND CONNECTIONS

---

Improper grounding is the largest single cause of UPS installation and start-up problems. This is not an easy subject, since grounding techniques vary significantly from site to site, depending on several factors. The questions you should ask are:

- What is the configuration of the input power source? Most of the recommended schemes for UPS grounding require grounded-wye service. The UPS system requires a bypass neutral for sensing and monitoring the quality of the bypass input. If the building service is straight delta or corner-grounded delta, contact your Liebert representative for details of the Artificial Neutral or Isolated Neutral kits for the System Control Cabinet.
- What are the UPS input and output voltages? Systems with 480 VAC input and output have significantly different needs than systems with 208/208 VAC.
- What is the connected load? Does the critical load consist of one or more Power Distribution Units (PDUs)? Do the PDUs have isolation transformers?

The following sections discuss recommended grounding procedures for various system configurations.



### **NOTE**

*Some UPS modules are equipped with input isolation transformers. However, these transformers have no effect upon any system grounding considerations. These modules will be grounded exactly as shown in the following examples.*

## 7.1 Preferred Grounding Configuration, 480 or 600 VAC Input and Output, Isolated Power Distribution Units, Wye-Connected Service

Figure 3 Preferred Grounding Configuration, 480 or 600 VAC Input and Output

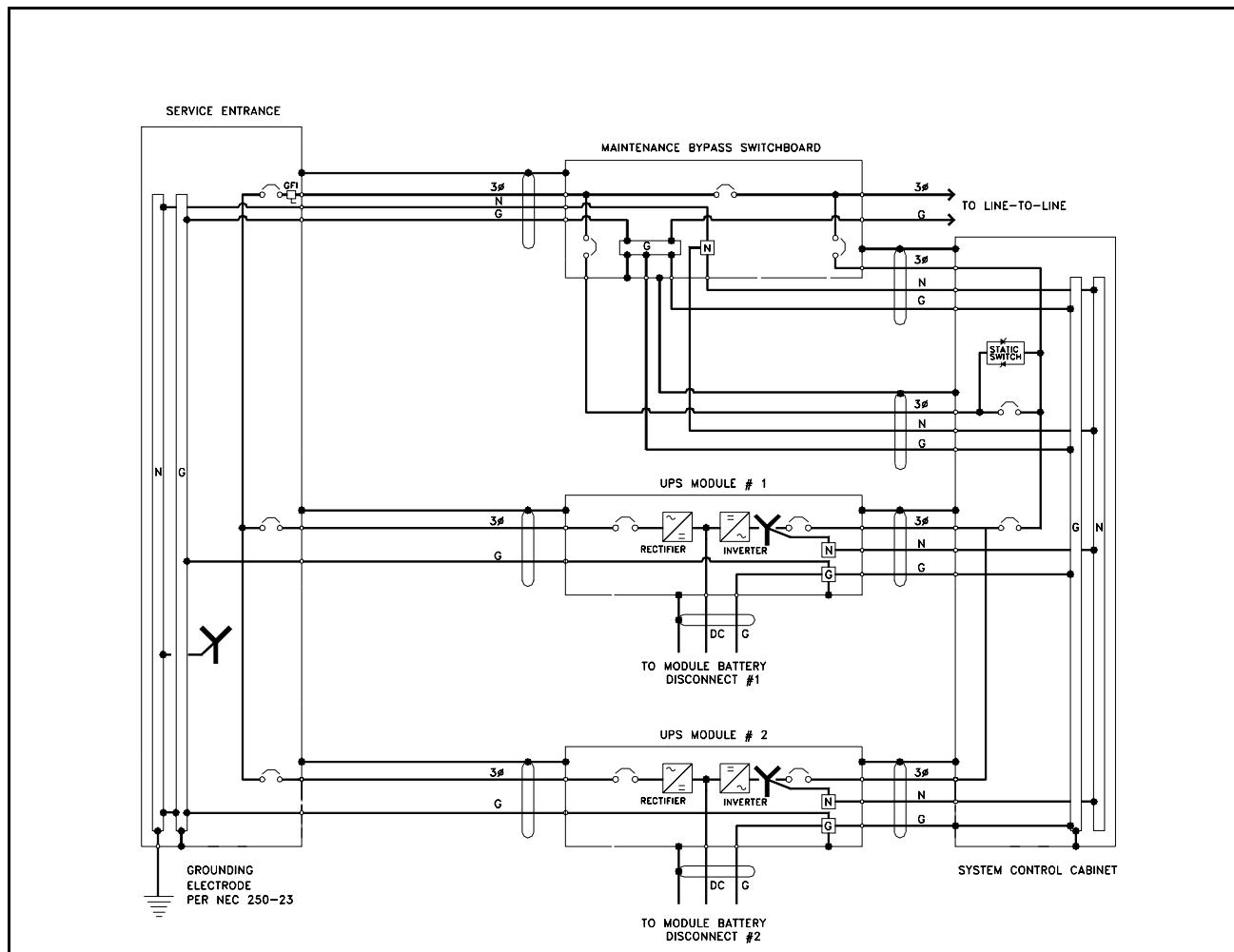

The most-common configuration of Series 600T UPS Multi-Module Systems is with 480 VAC input, 480 VAC output, and a connected load consisting of multiple Power Distribution Units (PDUs) with isolation transformers in the PDUs to produce 208 VAC. For Canadian customers, the UPS modules usually have 600 VAC input and output. The same principles apply if the connected load is an isolation transformer feeding various loads. Figure 3 above shows a typical installation. The Maintenance Bypass Switchgear is shown separately for clarity, but is usually contained within the System Control Cabinet (SCC).

Notice that the UPS module input and the system bypass input are connected to a grounded-wye service. In this configuration, the UPS module is not considered a separately derived source.

All of the UPS module output neutrals are solidly connected to the SCC neutral. The SCC neutral is solidly connected to the building service neutral, which is bonded to the grounding conductor at the service entrance equipment.

The isolation transformers in the PDUs can be considered separately derived sources. Therefore the PDU neutrals should be bonded to the PDU grounding conductor and connected to a local grounding electrode in compliance with NEC 250-26.



### NOTE

*Impedance-grounded wye sources require an Isolated Neutral Kit in addition to the grounding and neutral conductors shown above.*

## 7.2 Grounding Configuration, 480 or 600 VAC Input and Output, Delta Source

Figure 4 Grounding Configuration with Ungrounded Delta Source Input

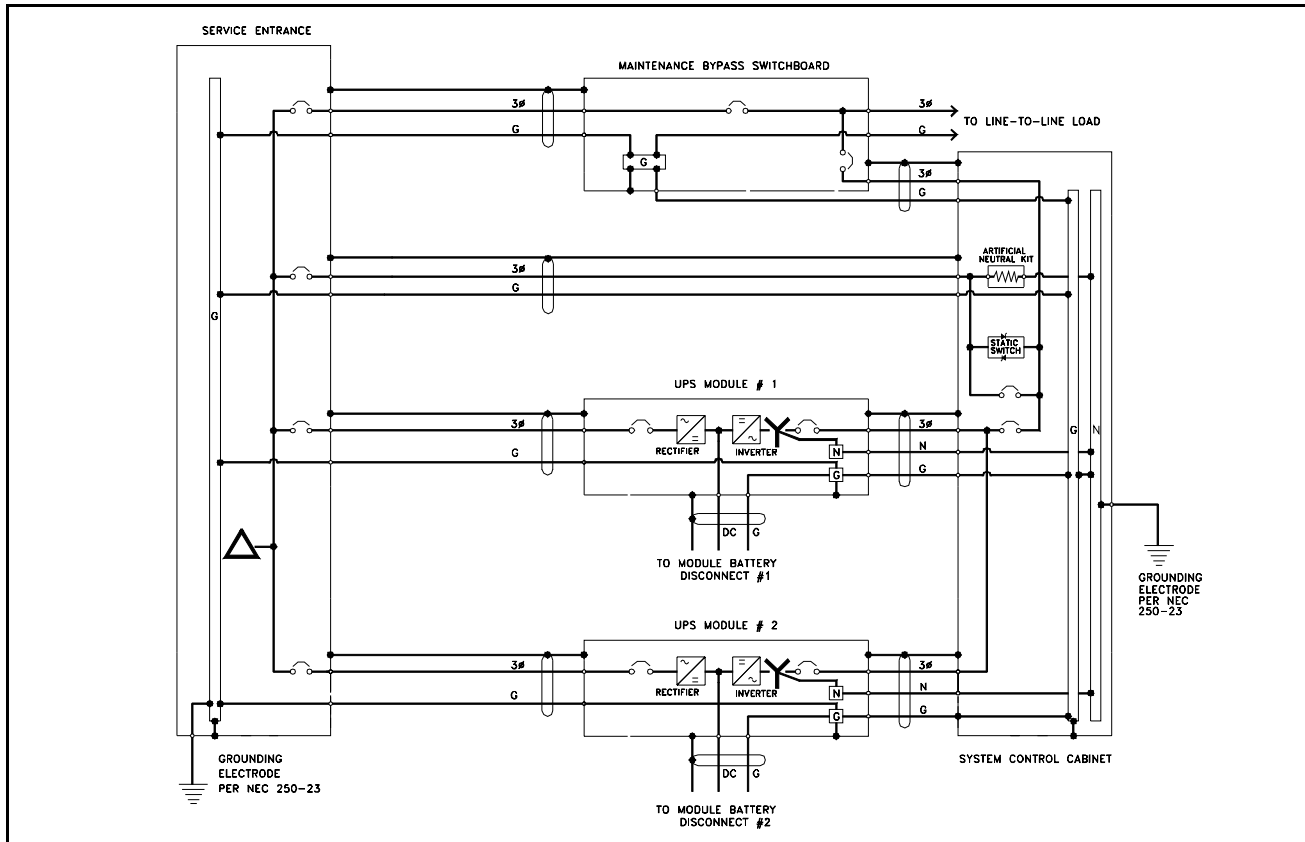

As previously mentioned, Series 600T UPS systems require a bypass input neutral for sensing and monitoring. With a wye-connected input source, the installer should always connect the building service neutral to the System Control Cabinet (SCC) output neutral to achieve this. When the building service is delta-connected, however, the installer must take special steps to ensure reliable UPS functioning.

If building service is *ungrounded delta* (and there is no intent to operate with one corner of the delta grounded, either on purpose or accidentally), the SCC requires the Series 600T Artificial Neutral Kit for proper operation. This kit uses a resistor network to create a reference point for the bypass input. In this case, the SCC output neutral *must* be bonded to the SCC ground.

If the building service is *corner-grounded delta* or an *Impedance-grounded wye*, the SCC requires the Isolated Neutral Kit. This kit uses control isolation transformers to create a reference point. For this application, the SCC output neutral *must not* be bonded to the SCC ground.



### NOTE

*The Artificial Neutral Kit introduces a maximum current of 0.3 amps to ground. Take care to ensure that this does not interfere with the operation of any upstream ground-fault detection devices.*

### 7.3 Preferred Grounding Configuration with Power-Tie Switchgear

Figure 5 Preferred Grounding Configuration, Power-Tie Systems

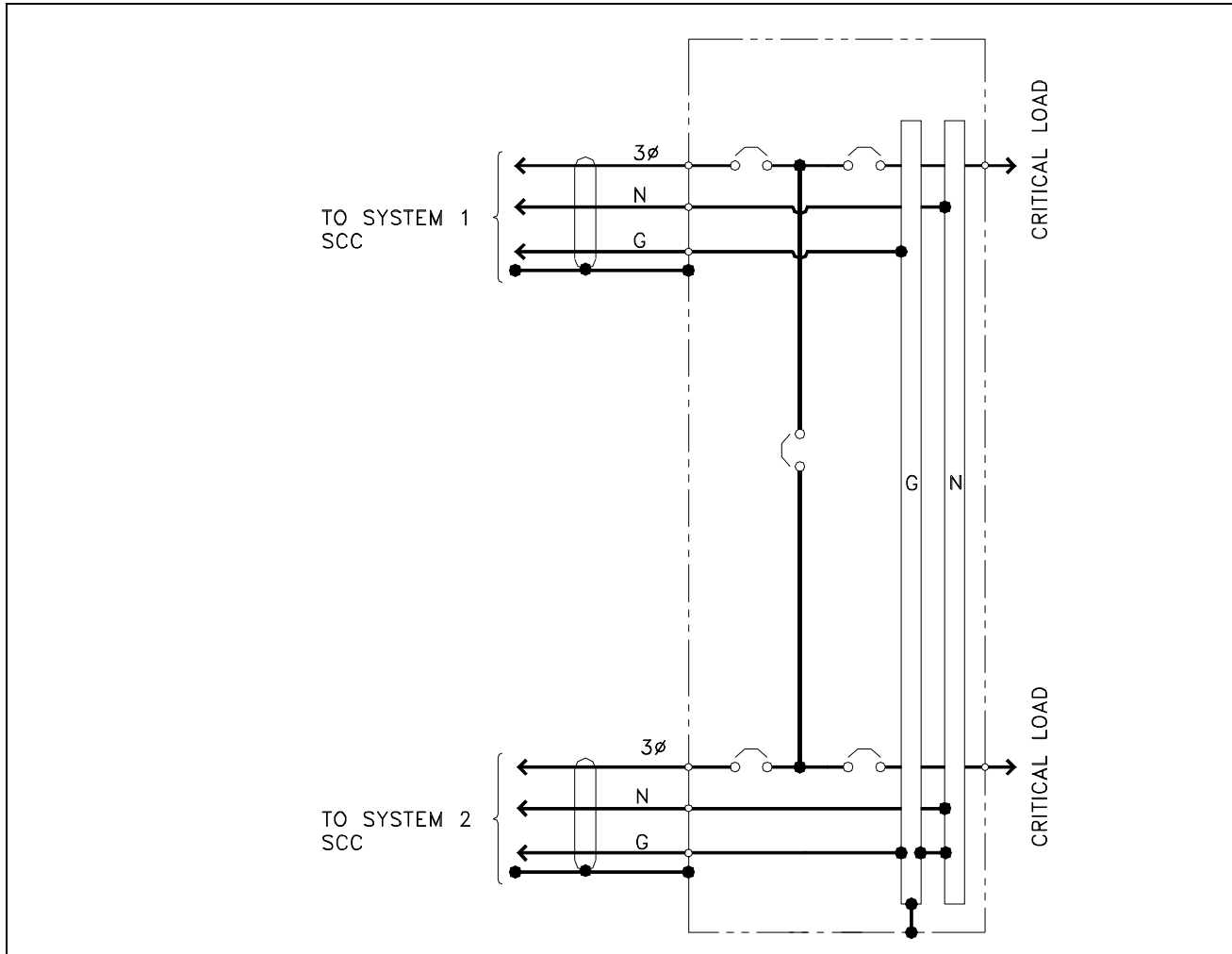

Multi-Module Systems can be used with Power-Tie switchgear to provide dual critical load busses. The Power-Tie switchgear permits transferring critical loads from one critical bus to the other so that one UPS system and associated breakers can be de-energized for maintenance. Certain configurations of Power-Tie equipment also permit the operator to continuously parallel the output of both UPS systems.

In tied systems, each SCC must have its neutral solidly connected to the Power-Tie switchgear neutral. The UPS modules, as usual, must have their output neutrals solidly connected to their respective SCC neutrals. There should *not* be a connection between the service entrance neutral and either the SCC or module neutrals.



**NOTE**

*It is essential to run a neutral connection between the tie switchgear and both SCCs as shown in the illustration above.*

## 7.4 Grounding Configurations, Battery Systems

Figure 6 Battery Cabinet Grounding Configuration

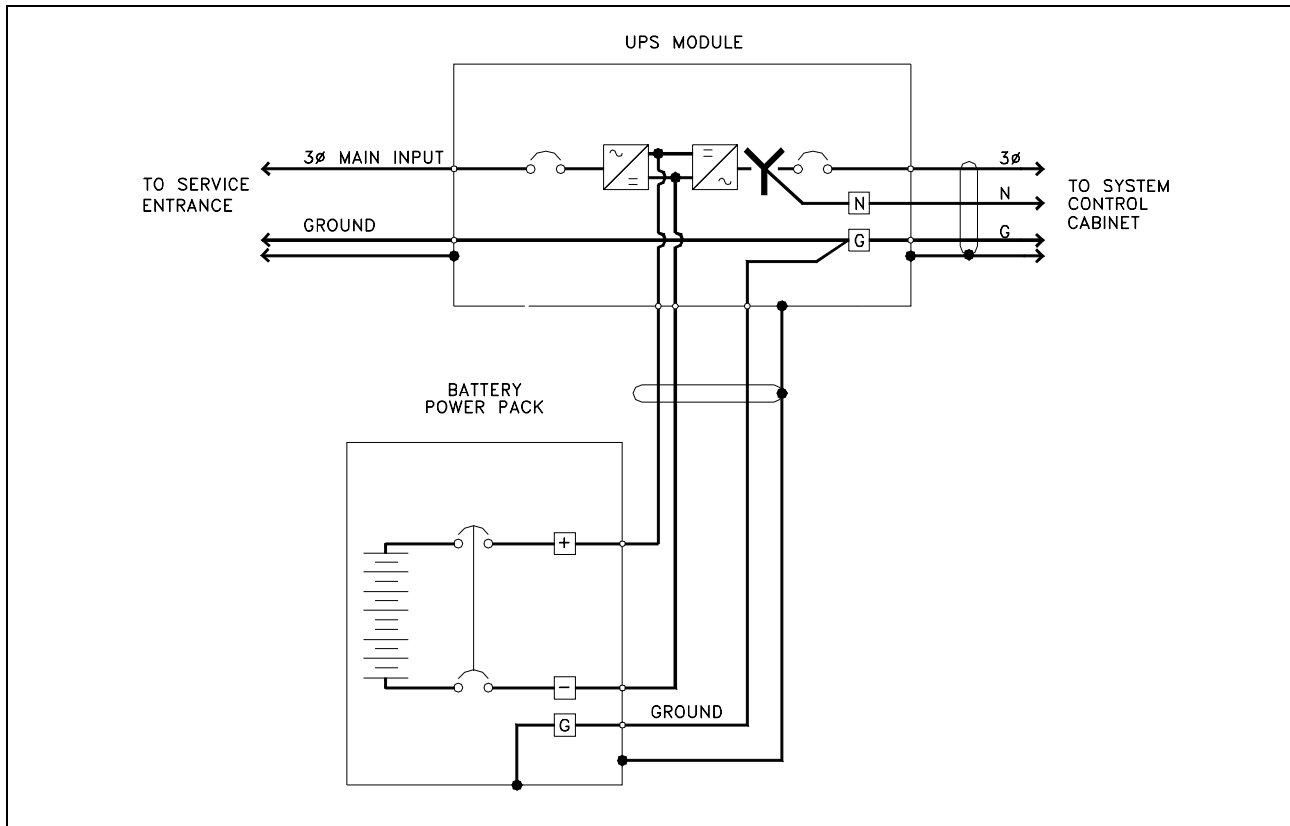

Large, open-rack battery systems are normally either locally grounded or left ungrounded, depending on local code requirements.

Battery cabinet systems, on the other hand, should be grounded to the UPS module ground bus. The figure above illustrates how a simple one-cabinet system would be grounded. For systems with multiple cabinets, the same configuration would apply. However, for simplicity the installer can connect all the battery cabinet grounds for a particular module together and run a single ground conductor to that UPS module ground.



---

## 8.0 WIRING CONSIDERATIONS

---



### WARNING

**ALL POWER CONNECTIONS MUST BE COMPLETED BY A LICENSED ELECTRICIAN THAT IS EXPERIENCED IN WIRING THIS TYPE OF EQUIPMENT. WIRING MUST BE INSTALLED IN ACCORDANCE WITH ALL APPLICABLE NATIONAL AND LOCAL ELECTRICAL CODES. IMPROPER WIRING MAY CAUSE DAMAGE TO THE EQUIPMENT OR INJURY TO PERSONNEL.**

**VERIFY THAT ALL INCOMING HIGH AND LOW VOLTAGE POWER CIRCUITS ARE DE-ENERGIZED AND LOCKED OUT BEFORE INSTALLING CABLES OR MAKING ANY ELECTRICAL CONNECTIONS.**

Refer to **Appendix A - Site Planning Data** and installation drawings (**Figure 8** through **Figure 58**). Determine AC currents for your system (kVA, voltage, and options). Also refer to equipment nameplate for the model number, rating, and voltage. Refer to **Table 1** and **Table 2** for wire termination data.



### NOTE

*Use 75°C copper wire. Select wire size based on the ampacities in **Table 3** of this manual, a reprint of Table 310-16 and associated notes of the National Electrical Code (NFPA 70).*



### CAUTION

**The weight of power cables must be adequately supported to avoid stress on bus bars and lugs. In addition to weight support, the following restraining method is recommended to control cable movement during external fault conditions: Wrap line cables together at 6 inches and 12 inches from the terminals with 5 wraps of 3/8 inch nylon rope or equivalent (tensile strength of 2000 pounds). Support remainder of cable with 5 wraps every 6 inches or 1 wrap every 1 inch.**

---

## 8.1 Power Wiring

1. Power wiring must be run in individual, separate conduits or cable trays. Refer to the Outline and Terminal Details drawings (**Figure 8 to Figure 15** and **Figure 29 to Figure 32**) for locations of the various power connections within the UPS and SCC. In particular, note the location of the rectifier input power connections.



### CAUTION

**Power and control wiring must be separated!**

2. Observe local, state and national electrical codes. Verify utility power and its overcurrent protection rating will accommodate the UPS input rating, including battery recharging.
3. A safety ground wire must be run from building ground to ground point in the UPS Module Cabinets, the System Control Cabinet, and the Power-Tie Cabinet (if applicable). See Sections 7.1 through 7.4. The grounding conductor shall comply with the following conditions of installation:
  - a. An insulated grounding conductor must be sized in accordance with the NEC and local codes. It must be green (with or without one or more yellow stripes) and be installed as part of the branch circuit that supplies the unit or system.
  - b. The grounding conductor described above is to be grounded to earth at the service equipment or, if supplied by a separately derived system, at the supply transformer or motor-generator set in accordance with the instructions in Section 7 of this Manual.
  - c. The attachment-plug receptacles in the vicinity of the unit or system are all to be of a grounding type, and the grounding conductors serving these receptacles are to be connected to earth ground at the service equipment.
4. When possible, input to the UPS and bypass should be four wire plus ground. When input is straight delta, the UPS artificial neutral kit should be ordered. When input is corner-grounded delta, the isolated neutral kit should be ordered.
5. Observe clockwise phase rotation of all power wiring. Phase A leads Phase B leads Phase C. A qualified electrician should check the phase rotation.
6. Power cables must be rated for less than 2 volts line drop at maximum rated system current.
7. If site equipment includes a backup generator and automatic transfer switch(es), consult the manufacturers of those devices for information on sizing and interfacing to the UPS system.
8. The installing contractor can remove the access plates from the left and right side of the cable-access area in the top of the UPS in order to cut entry holes for conduit. For units that also have bottom cable access, there is a third access plate on the right side of the module.



### CAUTION

**After cutting holes in the access plates, be certain that no foreign matter (metal shavings, sawdust, insulation or wire fragments, etc.) remains inside the UPS. Likewise be certain to block any “extra” holes in the plates through which foreign matter could later enter the UPS.**

---

## 8.2 Control Wiring

Control wiring must be stranded and tinned and run in individual separate steel conduits. Control wiring must be separated from power wiring. In addition, each control wiring cable group should be run in a separate conduit to minimize control signal interference.

Refer to the Control Connection Locations and Control Wire Lists, **Figure 33** through **Figure 52**. Notice that there are nine cable groups in a typical system:

- Cable group 1 carries signals for the Module Battery Disconnect.
- Cable group 2 is for the remote communications options: modem, remote terminal and remote CRT.
- Cable group 3 carries signals for the Remote Emergency Module Off and Remote Emergency Power Off.
- Cable group 4 carries signals for the optional Remote Status Panel.
- Cable group 5 is for the optional SiteScan system.
- Cable group 6 carries signals for the reduced battery charge limit and the reduced input current limit.
- Cable group 7 carries signals to and from the maintenance bypass switchgear.
- Cable groups 20 and 21 carry signals for general housekeeping, modules to SCC.

Other cable groups will be required for other optional equipment. If your system has any installed options, special wire lists will be included in your Submittal Drawing Package. Contact your Liebert Sales Representative for assistance if the submittal drawings have been lost or misplaced.

Figures AA and BB show the typical location of control connections inside the UPS and SCC. The position of a particular control connection may be different for your system, depending on the model and the installed options.



### **NOTE**

*The UPS control and communication wiring are considered Class 2 circuits by NEC standards. However, NEC Class 1 wiring methods are required for these circuits to ensure proper operation of the UPS.*

---

## 8.3 Battery Wiring

Power wiring to the Battery Cabinet connects positive, negative, and ground power cables from the Battery Cabinet to the associated UPS. Connection of the UPS to the Battery Cabinet serves to both charge and discharge the batteries (when needed). The battery disconnect (circuit breaker) requires a control cable. Liebert Battery Cabinets include power and control cables to join multiple cabinets together into a system. Additional (field-supplied) power or control wiring might be necessary to connect the battery cabinet system to the UPS. Refer to **Figure 16** through **Figure 18**.



### **DANGER**

**A BATTERY INTERCELL CONNECTION ON EACH TIER OF THE LIEBERT BATTERY CABINET IS DISCONNECTED FOR SAFETY DURING SHIPMENT. DO NOT COMPLETE THESE CONNECTIONS. THE LIEBERT GLOBAL SERVICES REPRESENTATIVE WILL COMPLETE THESE CONNECTIONS AS PART OF START-UP. AN IMPROPERLY INSTALLED UNIT CAN RESULT IN INJURY TO PERSONNEL OR DAMAGE TO EQUIPMENT.**



### **CAUTION**

**Be sure polarity is correct when wiring the Battery Cabinet to the connected equipment (positive to positive; negative to negative). If polarity is not correct, fuse failures or equipment damage can result.**



### **CAUTION**

**DC power cables should be installed in conduit with conductors in matched pairs (positive and negative).**



### **NOTE**

*A Liebert Battery Specialist can perform a detailed inspection of the entire battery system to ensure it meets current IEEE standards. This inspection service is recommended because batteries are a very critical part of the UPS system.*

Figure 7 Typical Multi-Module Configurations

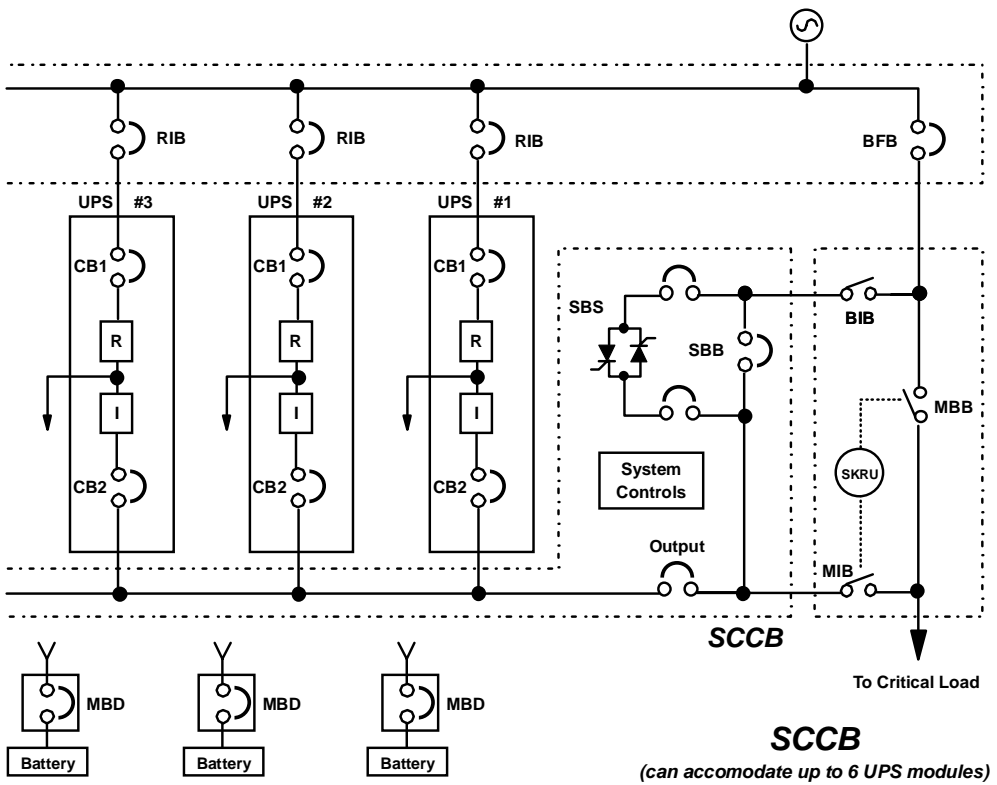
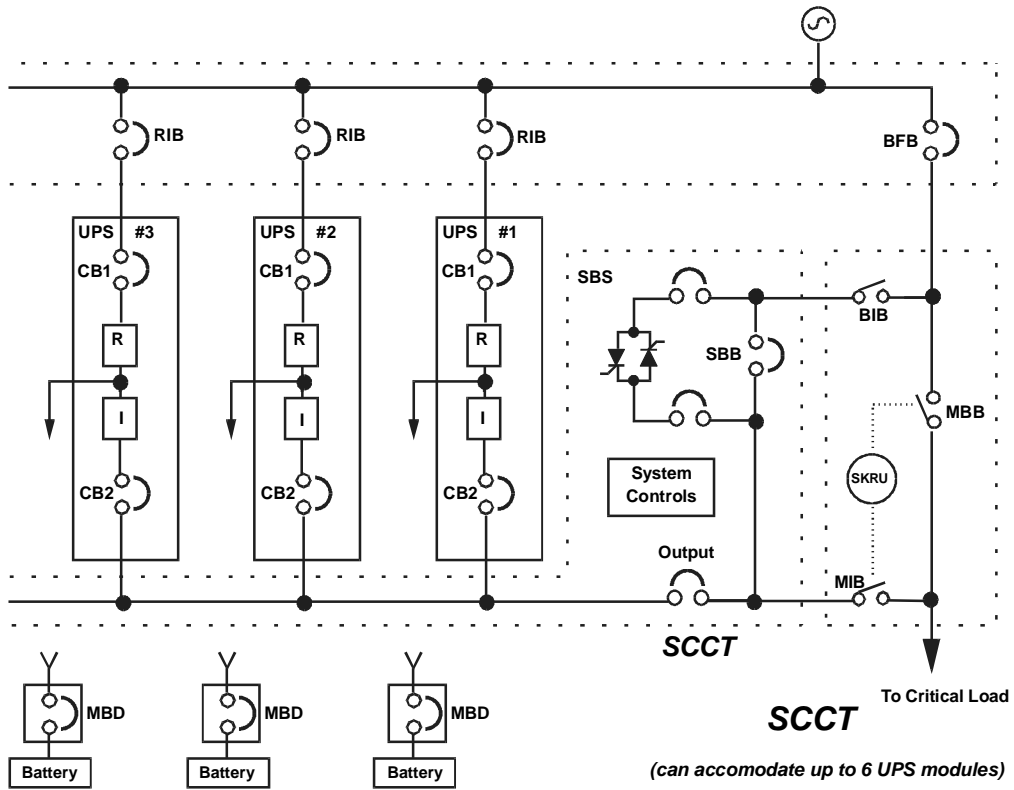
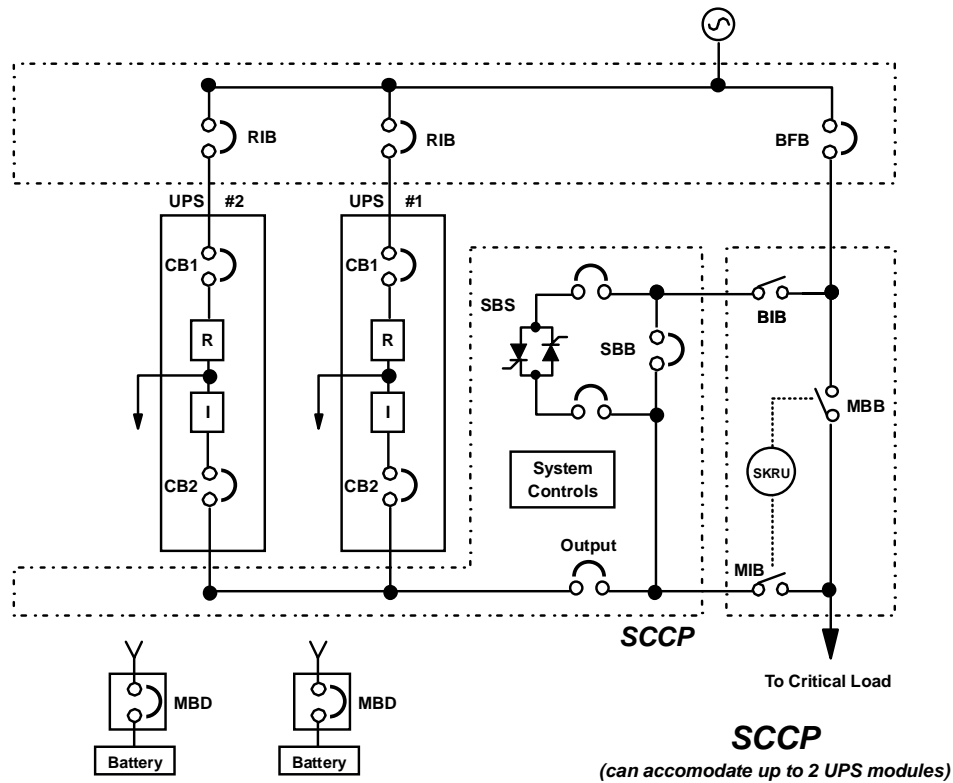
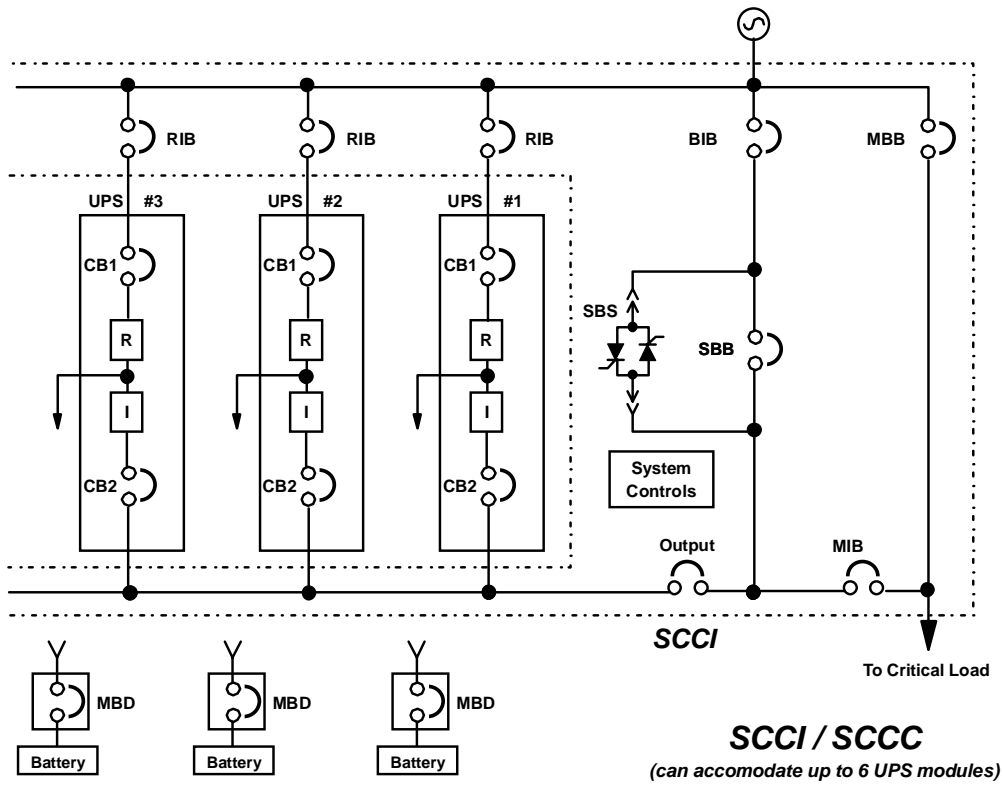

Figure 7 Typical Multi-Module Configurations (continued)



---

## 9.0 WIRING CONNECTIONS

---



### DANGER

**VERIFY THAT ALL INCOMING HIGH AND LOW VOLTAGE POWER CIRCUITS ARE DE-ENERGIZED AND LOCKED OUT BEFORE INSTALLING CABLES OR MAKING ELECTRICAL CONNECTIONS.**

**ALL POWER CONNECTIONS MUST BE COMPLETED BY A LICENSED ELECTRICIAN EXPERIENCED IN WIRING UPS EQUIPMENT, AND IN ACCORDANCE WITH ALL APPLICABLE NATIONAL AND LOCAL ELECTRICAL CODES.**

**IMPROPER WIRING MAY CAUSE DAMAGE TO THE UPS OR INJURY TO PERSONNEL.**



### CAUTION

**All shielded cables, non-shielded cables, non-shielded control wires, non-shielded battery breaker control wires, and non-shielded remote control wires must be housed in individual, separate, steel conduits. Placing multiple cables in the same conduit with other control or power wiring may cause system failure.**

Refer to the drawings in this manual and any other drawings provided by Liebert for this installation. Make all of the following connections:

1. AC power cables from input power source circuit breaker (RIB) to UPS Module Input. Observe phase rotation.
2. AC power cables from bypass power source circuit breaker (BIB) to UPS system bypass input at System Control Cabinet (SCC). Observe phase rotation.



### CAUTION

**See Section 7 of this Manual for an explanation of proper grounding techniques.**

3. AC power cables from UPS Module Outputs to SCC or to switchgear for critical load bus. Observe phase rotation.



### NOTE

*Make sure all required wiring between each UPS module and the optional cabinet(s) is completed. Observe phase rotation.*

4. Each UPS Module Output Neutral to SCC or to switchgear for critical load bus. See Section 7.

Abbreviations for Circuit Breakers	
BFB	Bypass Feeder Breaker
BIB	Bypass Input Breaker
CB1	Module Input Breaker
CB2	Module Output Breaker
MBB	Maintenance Bypass Breaker
MBD	Module Battery Disconnect
MBFB	Maintenance Bypass Feeder Breaker
MIB	Maintenance Isolation Breaker
RIB	Rectifier Input Breaker
SBB	System Bypass Breaker
SBS	Static Bypass Switch

- 
- The UPS System Output Neutral is connected to one common point and solidly grounded per requirements of the National Electrical Code. The ground connection inside the UPS SCC cabinet may be required by the power wiring configuration at your site.

**CAUTION**

**UPS bypass and system output neutral must be connected to only one common point in the UPS system. This neutral line must be grounded at the source.**

- For Battery Cabinets:

DC power cables (and ground) from Battery Cabinet to UPS Module, and between Battery Cabinets. Observe polarity. DC power cables should be installed in matched pairs (positive and negative).

**NOTE**

*DC power and battery circuit breaker control cables are provided with some Liebert-brand Battery Cabinets. Power cables are sized for interconnecting Battery Cabinets. Field-supplied cabling might be required to connect Battery Cabinets to the UPS module, depending on cabinet configuration and layout.*

**DANGER**

**DO NOT MAKE ANY CONNECTIONS BETWEEN BATTERY TIERS IN THE BATTERY CABINET. THESE CONNECTIONS WILL BE MADE BY THE LIEBERT CUSTOMER SERVICE REPRESENTATIVE DURING START-UP.**

- For remote battery, install DC power cables (and ground) from battery to Module Battery Disconnect, and then to UPS Module DC bus. Observe polarity.
- Module Battery Disconnect control wiring to UPS Module, and between Battery Cabinets if applicable.
- Control wiring from System Control Cabinet (SCC) to UPS modules. Wiring must be run in individual separate steel conduit.
- Power and control connections required for the Maintenance Bypass.
- Power connections from SCC to critical load bus. Observe phase rotation.
- Control wiring to Remote Monitor Panel, if used. Selected alarm messages are also available for customer use through a set of contacts on a separate terminal board. Wiring must be run in individual separate steel conduit.
- Emergency Power Off control wiring (to SCC) must be run in separate steel conduit.
- Communications wiring (to SCC) for terminals, site monitoring or for modem must be run in separate steel conduit.
- Any additional special wiring required at your site.



## 10.0 WIRING INSPECTION

1. Verify all power connections are tight.
2. Verify all control wire terminations are tight.
3. Verify all power wires and connections have proper spacing between exposed surfaces, phase-to-phase and phase-to-ground.
4. Verify that all control wires are run in individual, separate, steel conduit.

**Table 1 Power Wiring Terminals - Factory Supplied**

UPS Module Rating	Connection Type
500 kVA, 6-Pulse Rectifier	All power connections are top or bottom cable entry to busbars on the right side of module.
500 kVA, 12-Pulse Rectifier	Busbars for DC input, AC output, Neutral and Ground are provided on the right side of module, with top or bottom cable entry. Rectifier input is top entry directly to lugs on top of input circuit breaker.
625-750 kVA, standard models with standard input	Busbars for AC output, Neutral and Ground are provided on the right side of module, with top or bottom cable entry. Rectifier input is top entry directly to lugs on top of input circuit breaker. DC input is top entry to bus bars.
750 kVA/675 kW and other modules with optional input busbar kit	Busbars for AC output, Neutral and Ground are provided on the right side of module, with top or bottom cable entry. Rectifier input and DC input are top entry to bus bars.
Use 75°C copper wire. Select wire size based on the ampacities in <b>Table 310-16</b> (see <b>Table 3</b> of this manual) and associated notes of the National Electrical Code (NFPA 70). Use commercially available solderless lugs for the wire size required for your application. Connect wire to the lug using tool and procedure specified by the lug manufacturer.	

**Table 2 Torque Specifications**

Nut and Bolt Combinations				
Bolt Shaft Size	Grade 2 Standard		Electrical Connections with Belleville Washers	
	Lb-in	N-m	Lb-in	N-m
1/4	53	6.0	46	5.2
5/16	107	12	60	6.8
3/8	192	22	95	11
1/2	428	48	256	29
Circuit Breakers With Compression Lugs (For Power Wiring)				
Cable Size or Range	Lb-in	N-m		
#6 - #4	100	11		
#3 - #1	125	14		
1/0 - 2/0	150	17		
3/0 - 200 MCM	200	23		
250 - 400 MCM	250	28		
500 - 700 MCM	300	34		
Terminal Block Compression Lugs (For Control Wiring)				
AWG Wire Size or Range	Lb-in	N-m		
#22 - #14	3.5 to 5.3	0.4 to 0.6		

Use the values in this table unless the equipment is labeled with a different torque value.

**Table 3 Table 310-16**

**Allowable Ampacities of Insulated Conductors Rated 0-2000 Volts, 60° to 90°C (140° to 194°F)<sup>1</sup>**

Not More than Three Conductors in Raceway or Cable or Earth (Directly Buried), based on Ambient Temperature of 30° (86°F)

Size  AWG kcmil	Temperature Rating of Conductor. See Table 310-13.						Size  AWG kcmil
	60°C (140°F)	75°C (167°F)	90°C (194°F)	60°C (140°F)	75°C (167°F)	90°C (194°F)	
	Types TW* UF*	Types FEPW*, RH, RHW*, THHW*, THW*, THWN*, XHHW*, USE*, ZW*	Types TBS, SA, SIS FEP*, FEPB*, MI, RHH*, RHW-2, THHN*, THHW*, THW-2, THWN-2, USE-2, XHH, XHHW* XHHW-2, ZW-2	Types TW* UF*	Types RH*, RHW*, THHW*, THW*, THWN*, XHHW*, USE*	Types TBS, SA, SIS, THHN*, THHW*, THW-2, THWN-2, RHH*, RHW-2, USE-2, XHH, XHHW*, XHHW-2, ZW-2	
Copper			Aluminum or Copper-Clad Aluminum				
18	.....	.....	14	.....	.....	.....	.....
16	.....	.....	18	.....	.....	.....	.....
14	20†	20†	25†	.....	.....	.....	.....
12	25†	25†	30†	20†	20†	25†	12
10	30	35†	40†	25	30†	35†	10
8	40	50	55	30	40	45	8
6	55	65	75	40	50	60	6
4	70	85	95	55	65	75	4
3	85	100	110	65	75	85	3
2	95	115	130	75	90	100	2
1	110	130	150	85	100	115	1
1/0	125	150	170	100	120	135	1/0
2/0	145	175	195	115	135	150	2/0
3/0	165	200	225	130	155	175	3/0
4/0	195	230	260	150	180	205	4/0
250	215	255	290	170	205	230	250
300	240	285	320	190	230	255	300
350	260	310	350	210	250	280	350
400	280	335	380	225	270	305	400
500	320	380	430	260	310	350	500
600	355	420	475	285	340	385	600
700	385	460	520	310	375	420	700
750	400	475	535	320	385	435	750
800	410	490	555	330	395	450	800
900	435	520	585	355	425	480	900
1000	455	545	615	375	445	500	1000
1250	495	590	665	405	485	545	1250
1500	520	625	705	435	520	585	1500
1750	545	650	735	455	545	615	1750
2000	560	665	750	470	560	630	2000
Correction Factors							
Ambient Temp °C	For ambient temperatures other than 30°C (86°F), multiply the allowable ampacities shown above by the appropriate factor shown below.						Ambient Temp °F
21-25	1.08	1.05	1.04	1.08	1.05	1.04	70-77
26-30	1.00	1.00	1.00	1.00	1.00	1.00	78-86
31-35	.91	.94	.96	.91	.94	.96	87-95
36-40	.82	.88	.91	.82	.88	.91	96-104
41-45	.71	.82	.87	.71	.82	.87	105-113
46-50	.58	.75	.82	.58	.75	.82	114-122
51-55	.41	.67	.76	.41	.67	.76	123-131
56-60	.....	.58	.71	.....	.58	.71	132-140
61-70	.....	.33	.58	.....	.33	.58	141-158
71-80	.....	.....	.41	.....	.....	.41	159-176
<p>* Unless otherwise specifically permitted elsewhere in this Code, the overcurrent protection for conductor types marked with an asterisk (*) shall not exceed 15 amperes for No. 14, 20 amperes for No. 12, and 30 amperes for No. 10 copper; or 15 amperes for No. 12 and 25 amperes for No. 10 aluminum and copper-clad aluminum after any correction factors for ambient temperature and number of conductors have been applied.</p> <p><sup>1</sup> Reprinted with permission from NEC 1999, NFPA 70, the National Electrical Code®, Copyright 1998, National Fire Protection Association, Quincy, MA 02269. This reprinted material is not the complete and official position of the National Fire Protection Association, on the referenced subject which is represented only by the standard in its entirety.</p>							

# 11.0 INSTALLATION DRAWINGS

Figure 8 Outline Drawing, 500 kVA Multi-Module UPS, 6-Pulse Rectifier

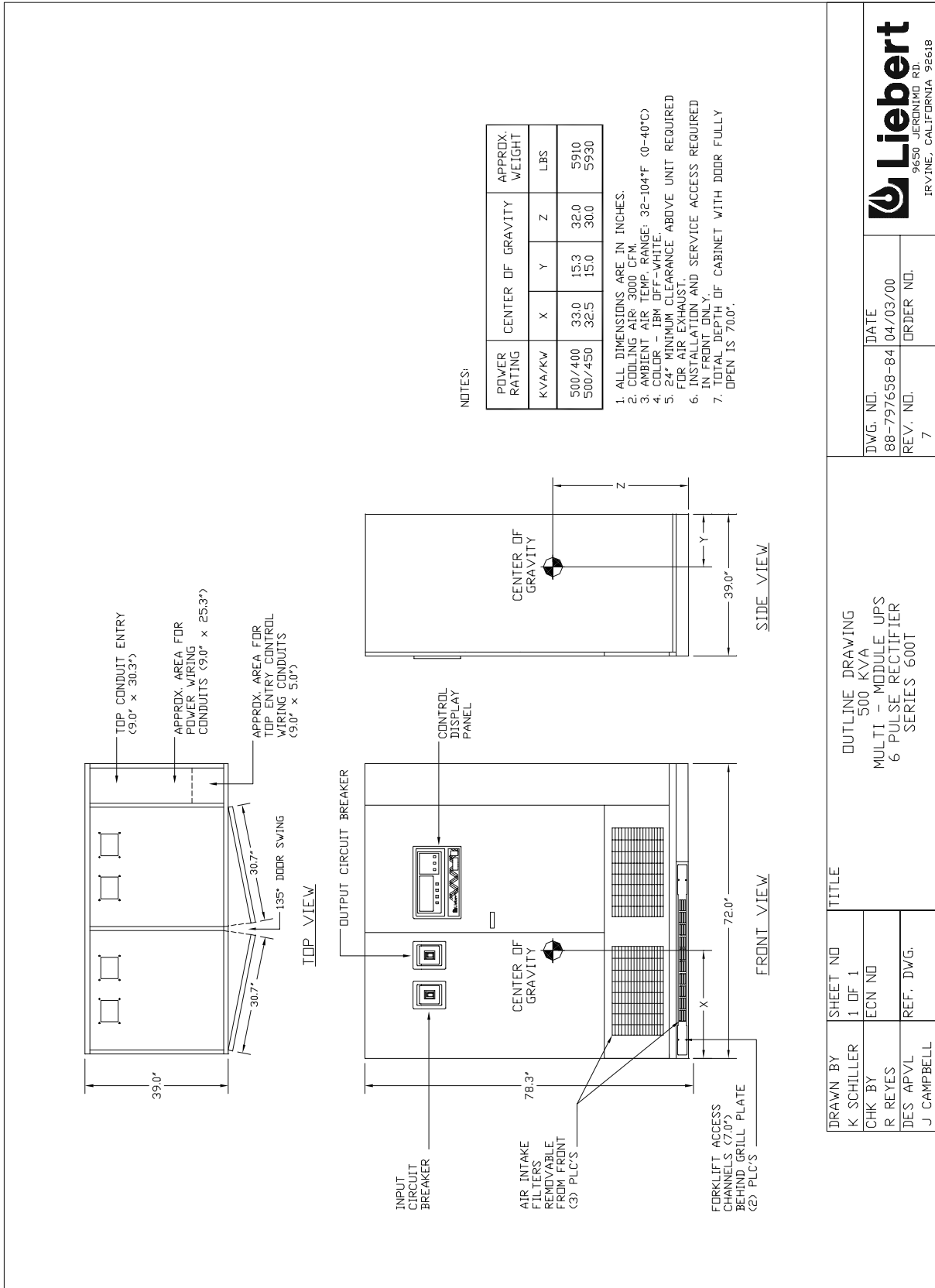

DRAWN BY K. SCHILLER		SHEET NO 1 OF 1		TITLE OUTLINE DRAWING 500 KVA MULTI - MODULE UPS 6 PULSE RECTIFIER SERIES 600T	
CHK BY R. REYES		ECN NO		DWG. NO. 88-797658-84	
DES APVL J. CAMPBELL		REF. DWG.		DATE 04/03/00	
				ORDER NO.	
				7	

  
 9650 JERONIMO RD.  
 IRVINE, CALIFORNIA 92618

FILE NAME: 88-797658-84-07.DWG

Figure 9 Outline Drawing, 500 kVA Multi-Module UPS, 12-Pulse Rectifier

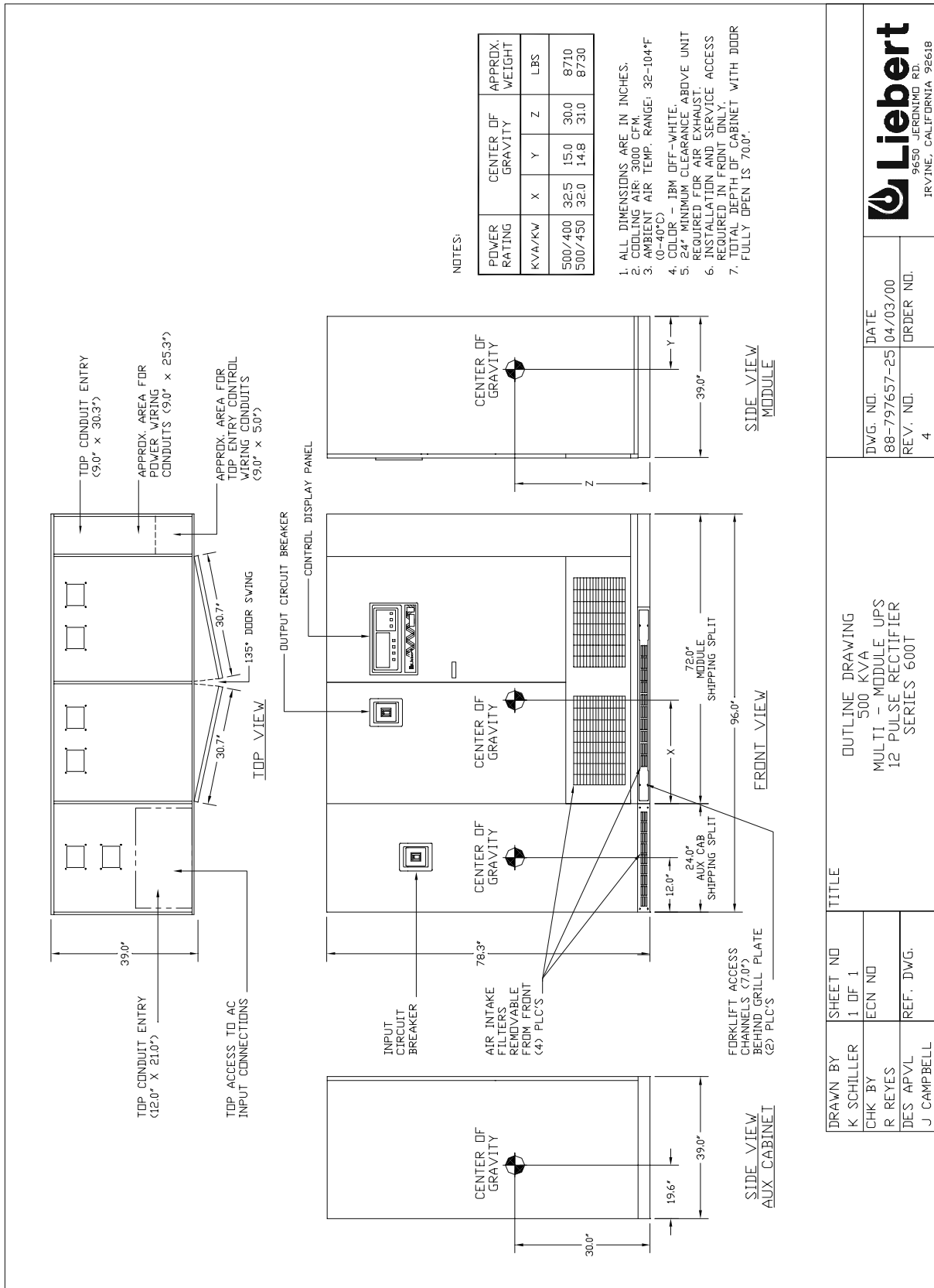

DRAWN BY K SCHILLER		SHEET NO 1 OF 1		TITLE OUTLINE DRAWING	
CHK BY R REYES		ECN NO		500 KVA MULTI - MODULE UPS 12 PULSE RECTIFIER SERIES 600T	
DES APVL J CAMPBELL		REF. DWG.		DWG. NO. 88-797657-25	DATE 04/03/00
				REV. NO. 4	ORDER NO.
FILE NAME: 88-797657-25-04.DWG					



Figure 10 Outline Drawing, 625-750 kVA Multi-Module UPS, 6-Pulse Rectifier

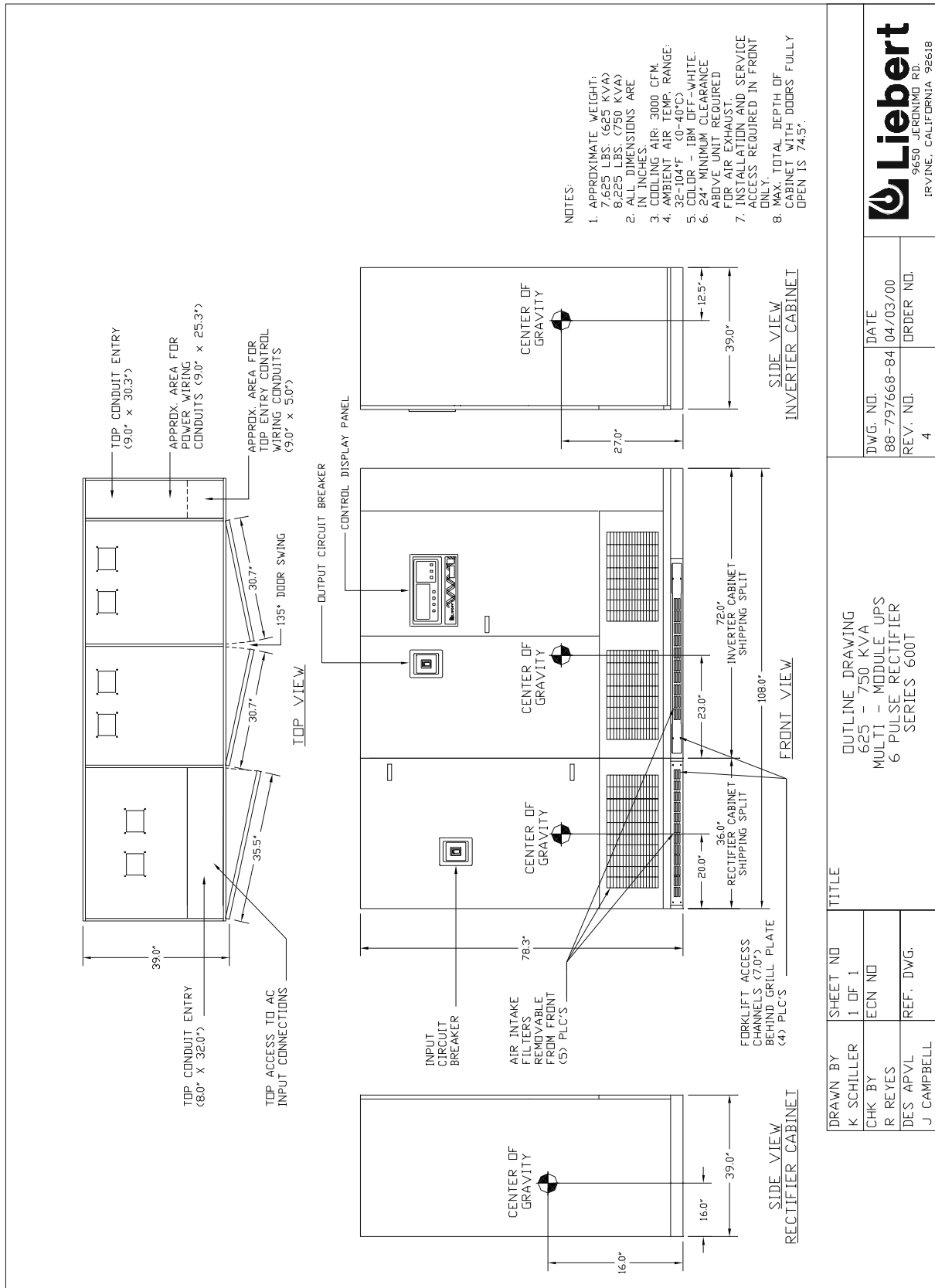
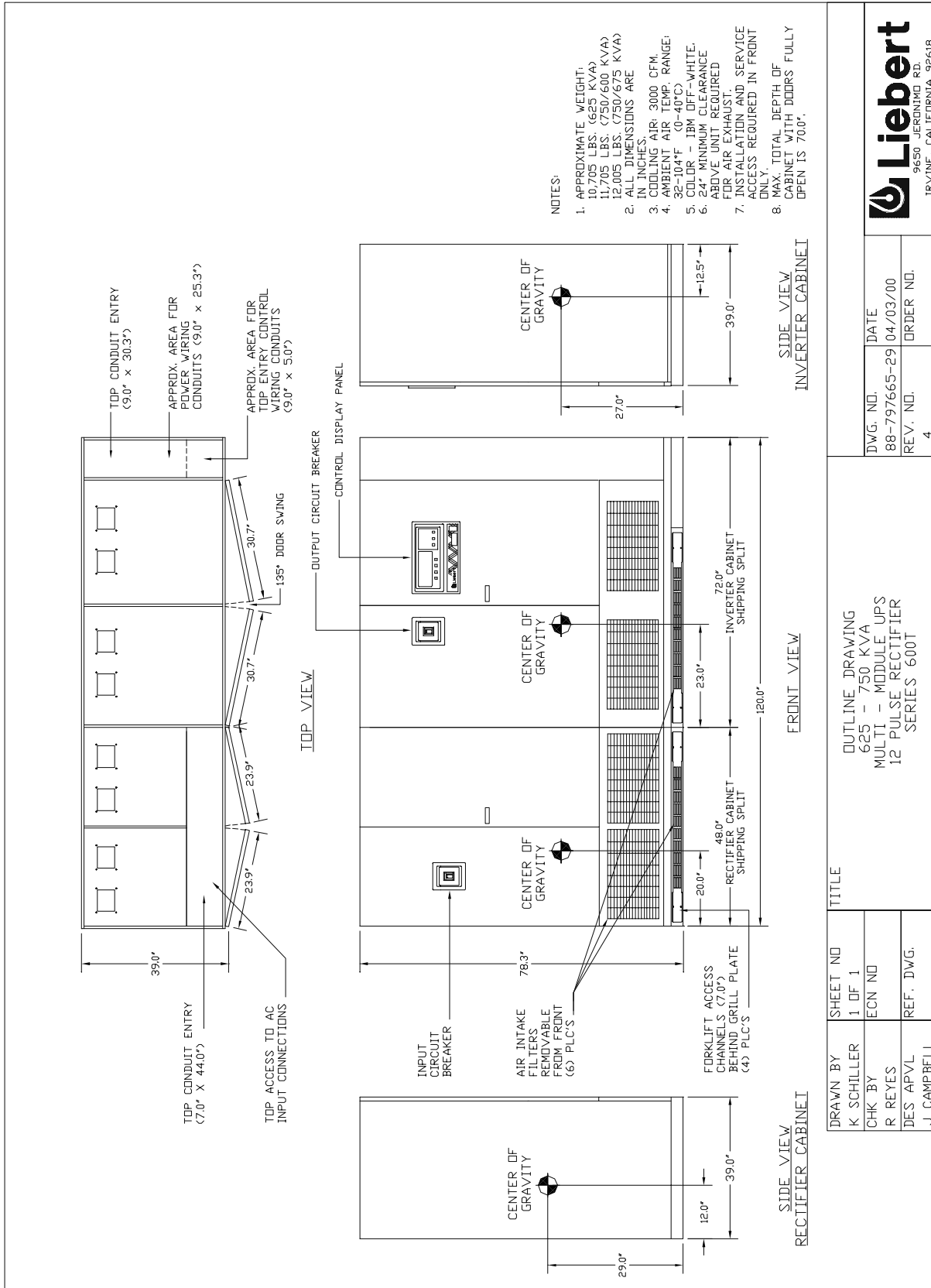

Figure 11 Outline Drawing, 625-750 kVA Multi-Module UPS, 12-Pulse Rectifier



DWG. NO.	DATE
88-797665-29	04/03/00
REV. NO.	ORDER NO.
4	

FILE NAME: 88-797665-29-04.DWG

TITLE	
OUTLINE DRAWING 625 - 750 KVA MULTI - MODULE UPS 12 PULSE RECTIFIER SERIES 600T	

DRAWN BY	SHEET NO
K SCHILLER	1 OF 1
CHK BY	ECN NO
R REYES	
DES APVL	REF. DWG.
J CAMPBELL	

Figure 12 Outline Drawing, System Control Cabinet (SCCT), 200-1200 Amps

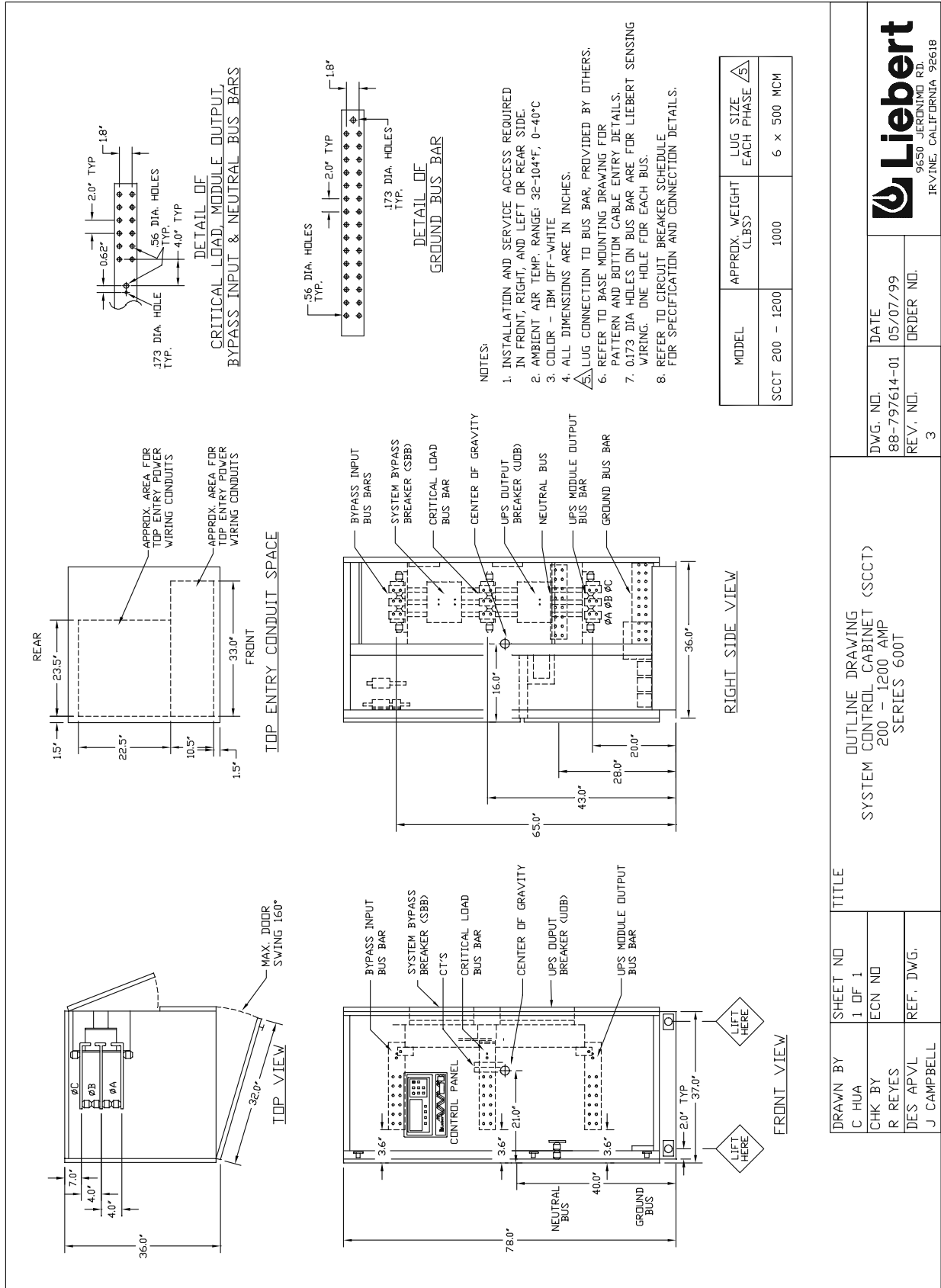

Figure 13 Outline Drawing, System Control Cabinet (SCCT), 1600-2500 Amps

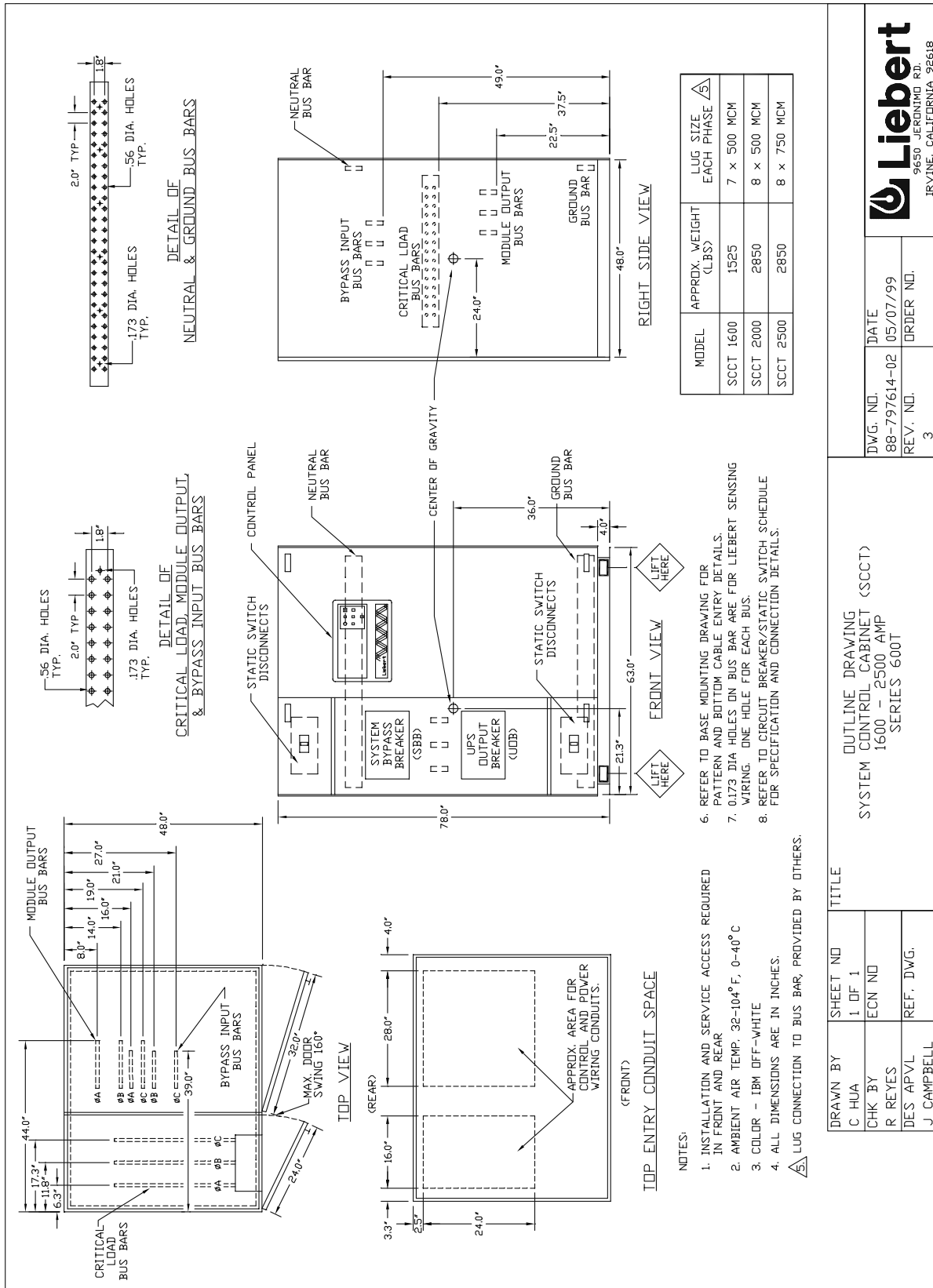



Figure 14 Outline Drawing, System Control Cabinet (SCCT), 3000 Amps

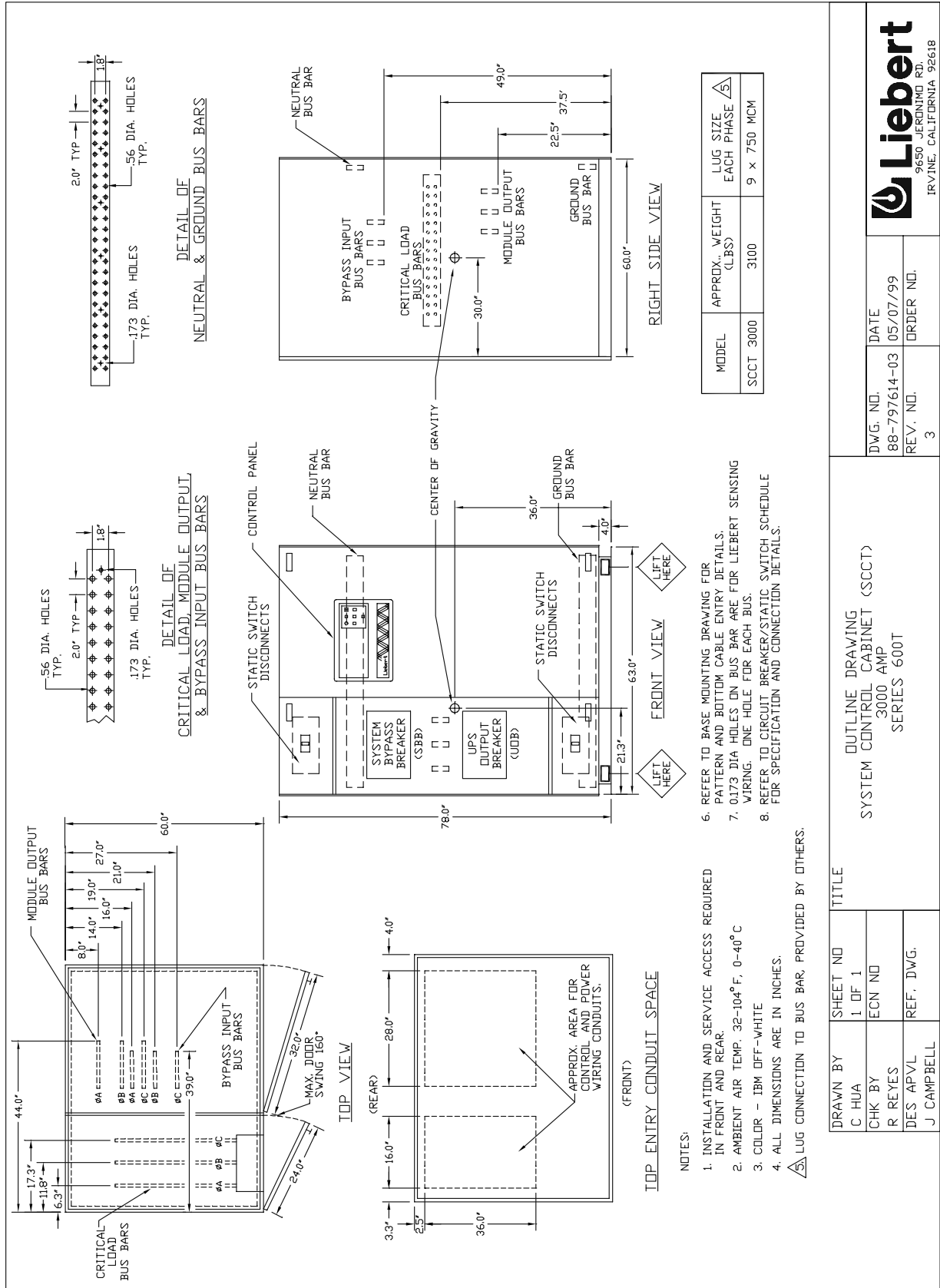
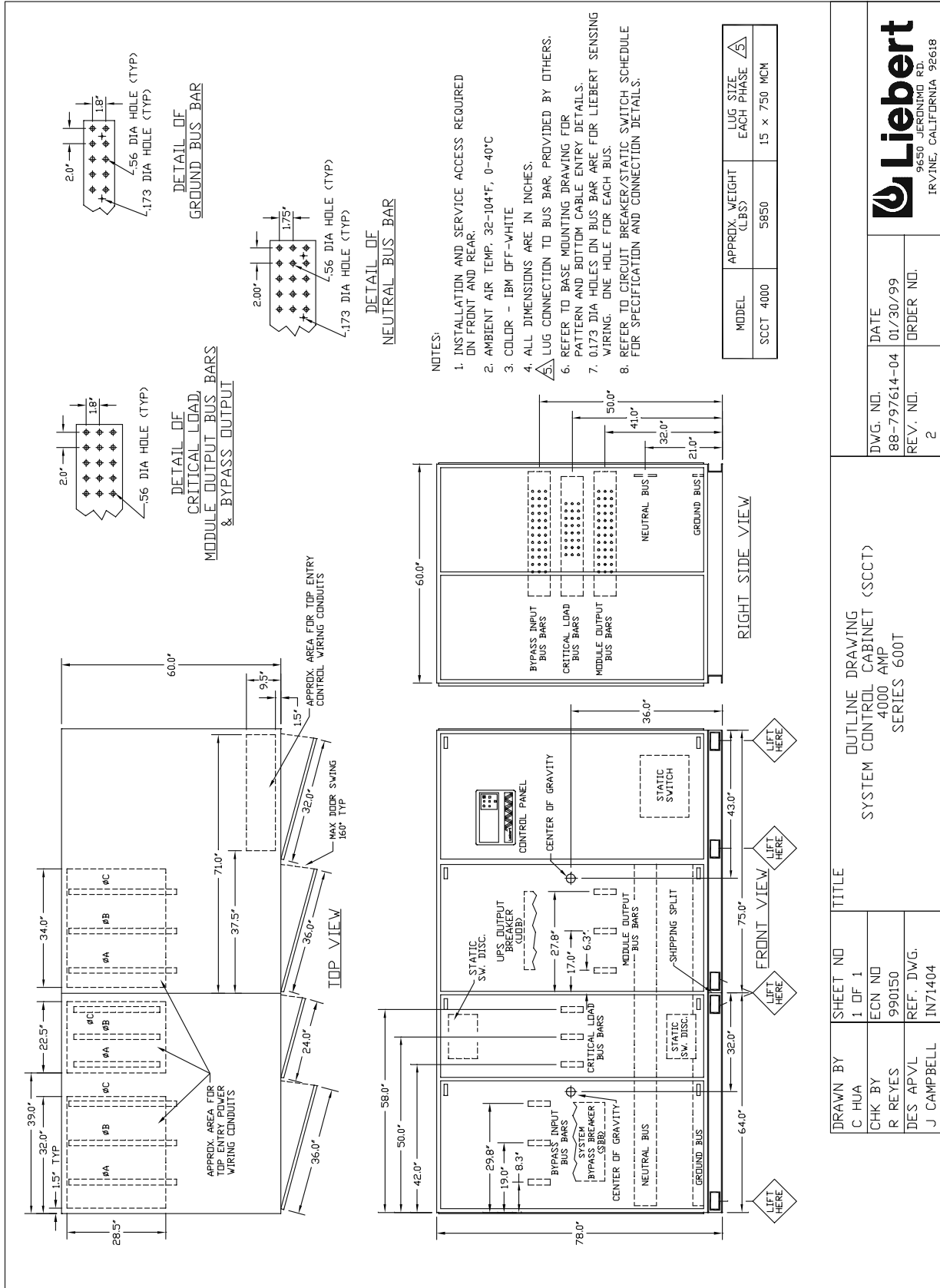
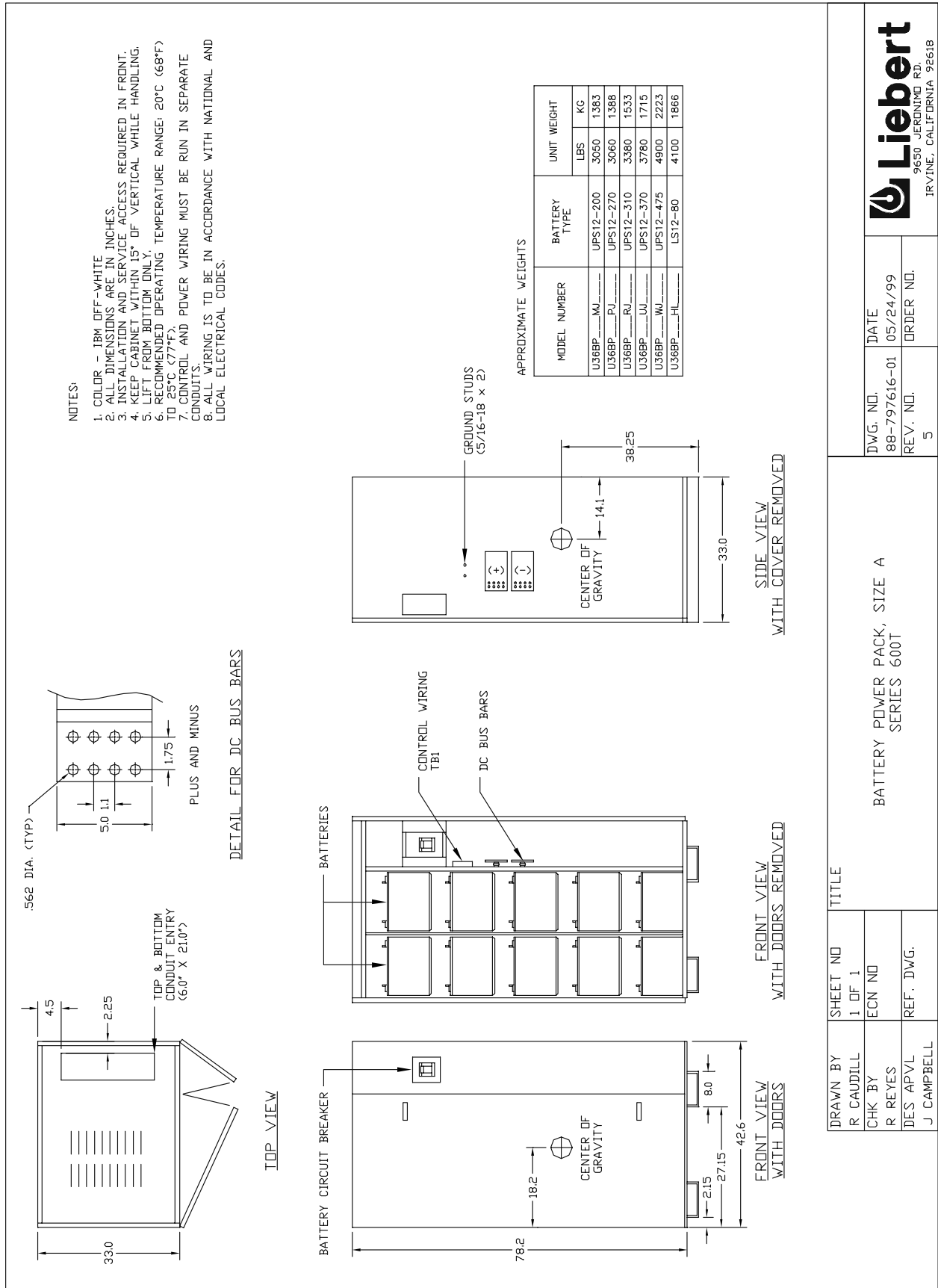

Figure 15 Outline Drawing, System Control Cabinet (SCCT) 4000 Amps



DRAWN BY		SHEET NO		TITLE	
C HUA	1 OF 1	OUTLINE DRAWING SYSTEM CONTROL CABINET (SCCT) 4000 AMP SERIES 600T			
CHK BY	EGN NO				
R REYES	990150				
DES APVL	REF. DWG.				
J CAMPBELL	IN71404				

Figure 16 Battery Power Pack, Size A



DRAWN BY R CAUDILL		SHEET NO 1 OF 1		TITLE BATTERY POWER PACK, SIZE A	
CHK BY R REYES		ECN NO		SERIES 600T	
DES APVL J CAMPBELL		REF. DWG.		DWG. NO. 88-797616-01	
				DATE 05/24/99	
				REV. NO. 5	
				ORDER NO.	
				FILE NAME: 88-797616-01-05.DWG	



Figure 17 Battery Power Pack, Size B

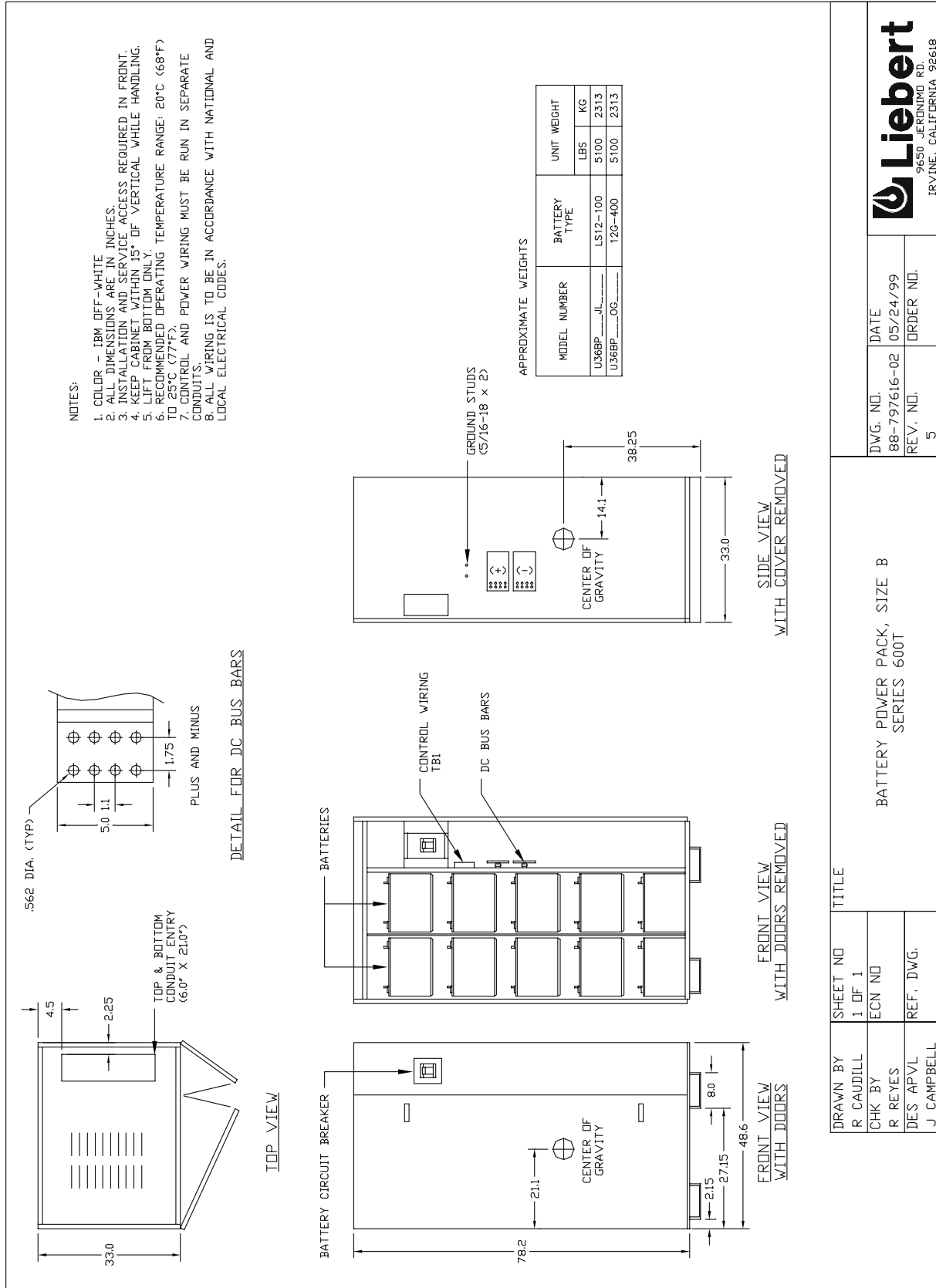
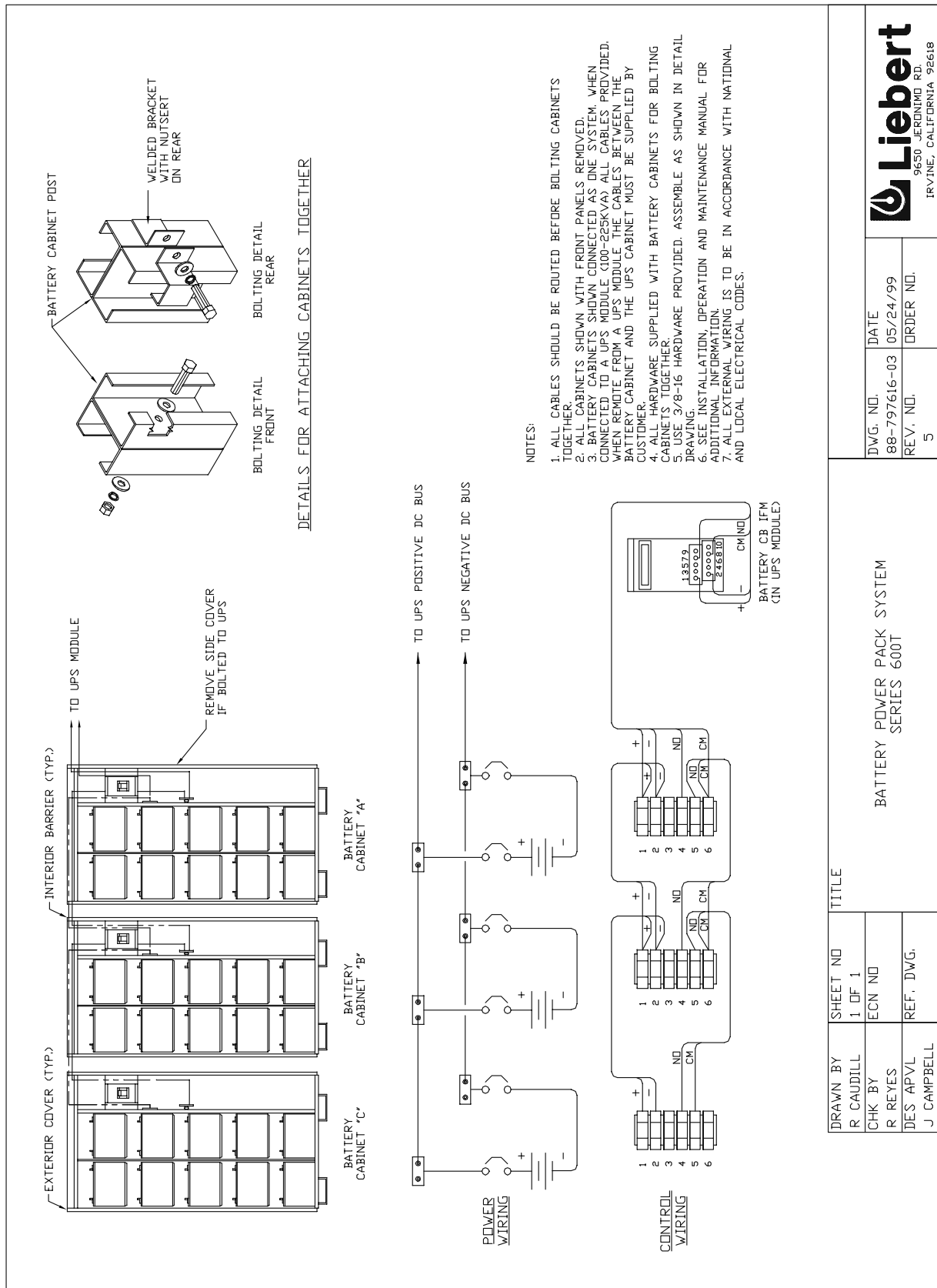

Figure 18 Battery Power Pack, Three-Pack System



DWG. NO. 88-797616-03  
 REV. NO. 5  
 DATE 05/24/99  
 ORDER NO.

BATTERY POWER PACK SYSTEM  
 SERIES 600T

TITLE	
DRAWN BY R CAUDILL	SHEET NO 1 OF 1
CHK BY R REYES	ECN NO
DES APVL J CAMPBELL	REF. DWG.

FILE NAME: 88-797616-03-03.DWG

Figure 19 Base Mounting Patterns, 500 kVA Module, 12-Pulse Rectifier

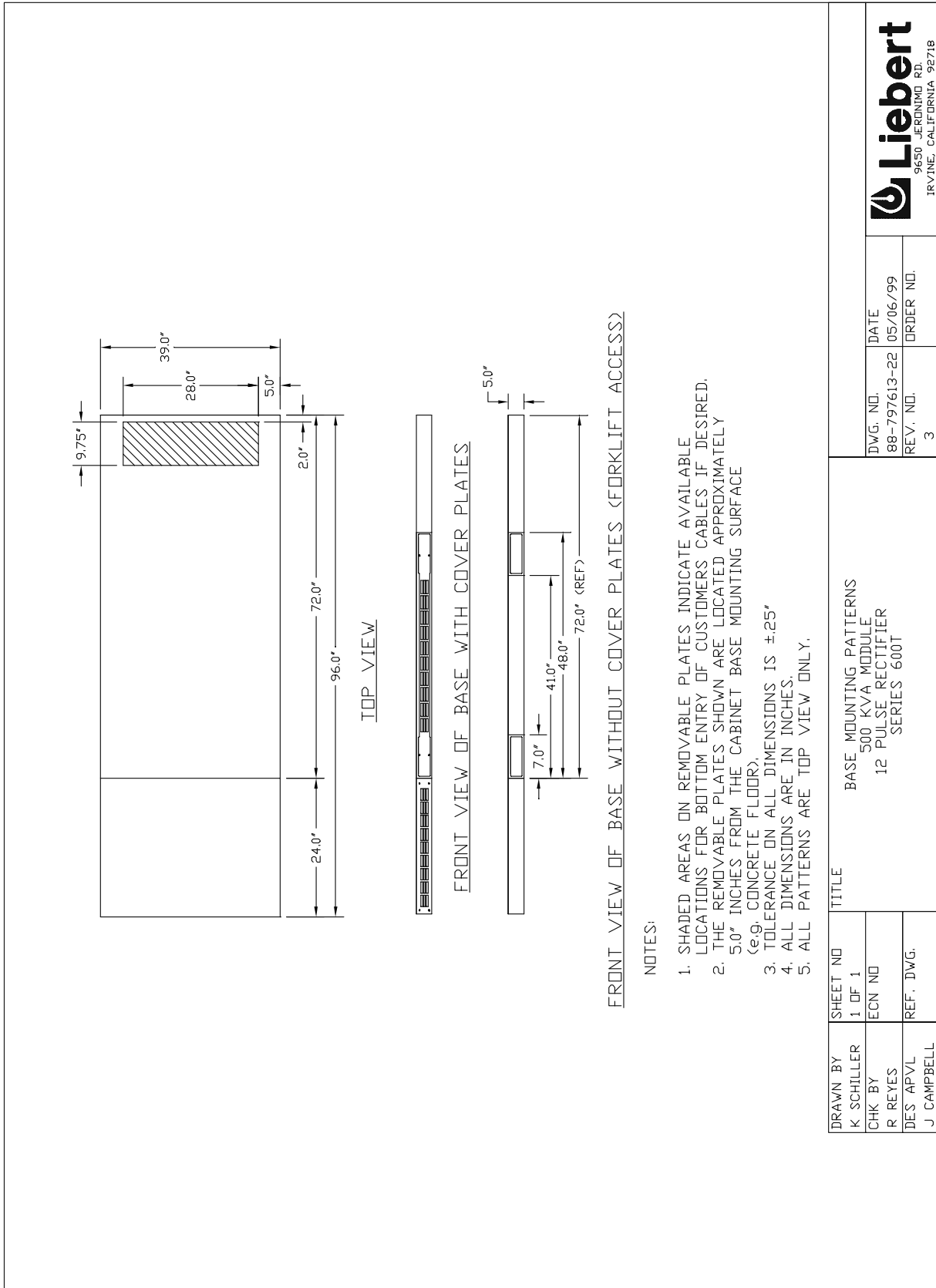

DRAWN BY K SCHILLER	SHEET NO 1 OF 1	TITLE BASE MOUNTING PATTERNS 500 KVA MODULE 12 PULSE RECTIFIER SERIES 600T		DWG. NO. 88-797613-22	DATE 05/06/99
CHK BY R REYES	ECN NO			REV. NO. 3	ORDER NO.
DES. APVL J CAMPBELL	REF. DWG.			FILE NAME: 88-797613-22-03.DWG	



Figure 20 Base Mounting Patterns, 625-750 kVA Module, 6-Pulse

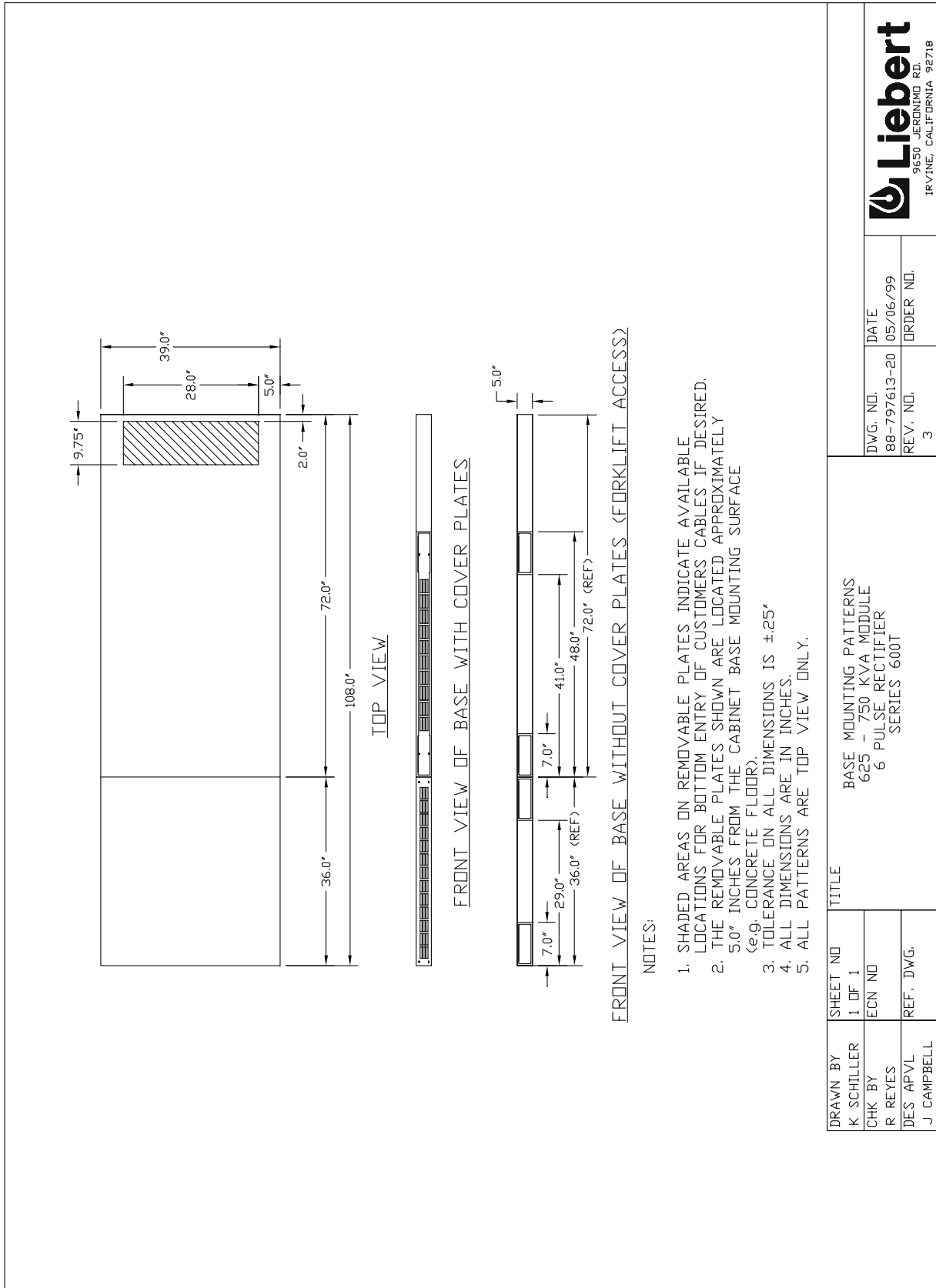

DWG. NO.	DATE
88-797613-20	05/06/99
REV. NO.	ORDER NO.
3	

FILE NAME: 88-797613-20-03.DWG

DRAWN BY	SHEET NO	TITLE
K SCHILLER	1 OF 1	BASE MOUNTING PATTERNS
CHK BY	ECN NO	625 - 750 KVA MODULE
R REYES		6 PULSE RECTIFIER
DES APVL	REF. DWG.	SERIES 600T
J CAMPBELL		

Figure 21 Base Mounting Patterns, 625-750 kVA Module, 12-Pulse Rectifier

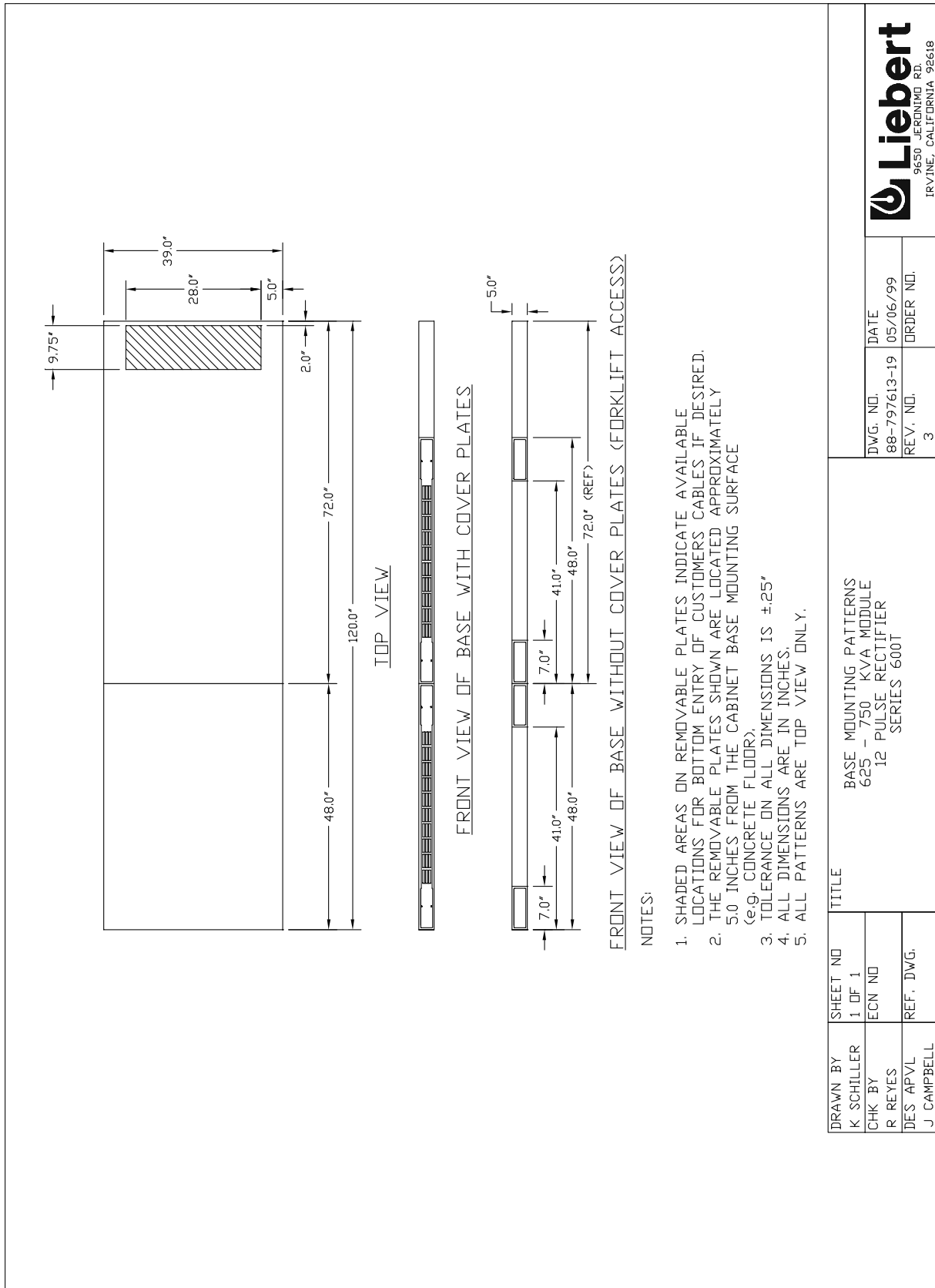
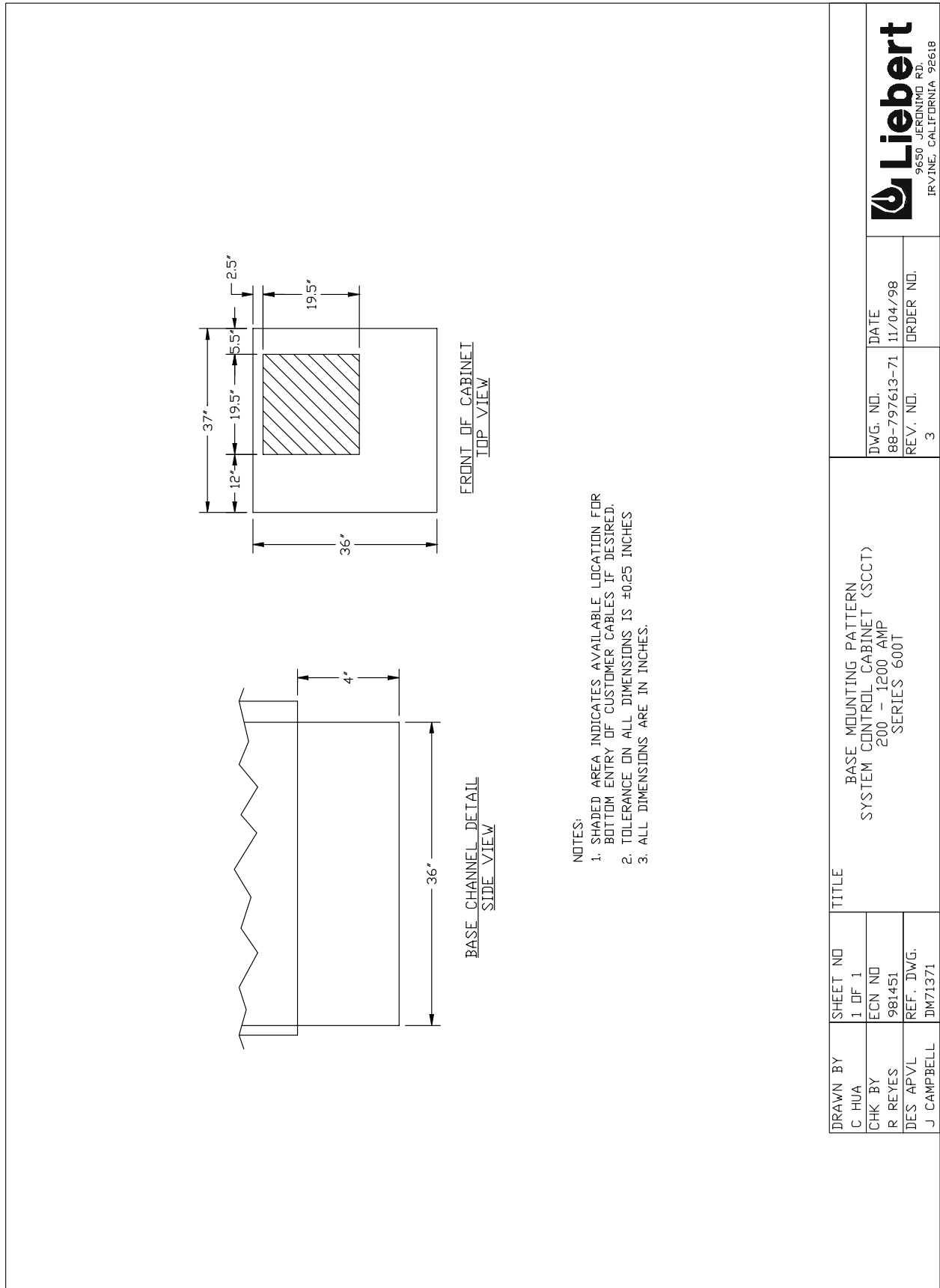



Figure 22 Base Mounting Patterns, System Control Cabinets (SCCT) 200-1200 Amps



DRAWN BY C HUA	SHEET NO 1 OF 1	TITLE BASE MOUNTING PATTERN SYSTEM CONTROL CABINET (SCCT) 200 - 1200 AMP SERIES 600T	
CHK BY R REYES	ECN NO 981451	DWG. NO. 88-797613-71	DATE 11/04/98
DES. APVL J CAMPBELL	REF. DWG. DM71371	REV. NO. 3	ORDER NO.
		 9650 JERONIMO RD. IRVINE, CALIFORNIA 92618	

FILE NAME: DM71371.DWG

Figure 23 Base Mounting Patterns, System Control Cabinet (SCCT), 1600-2500 Amps

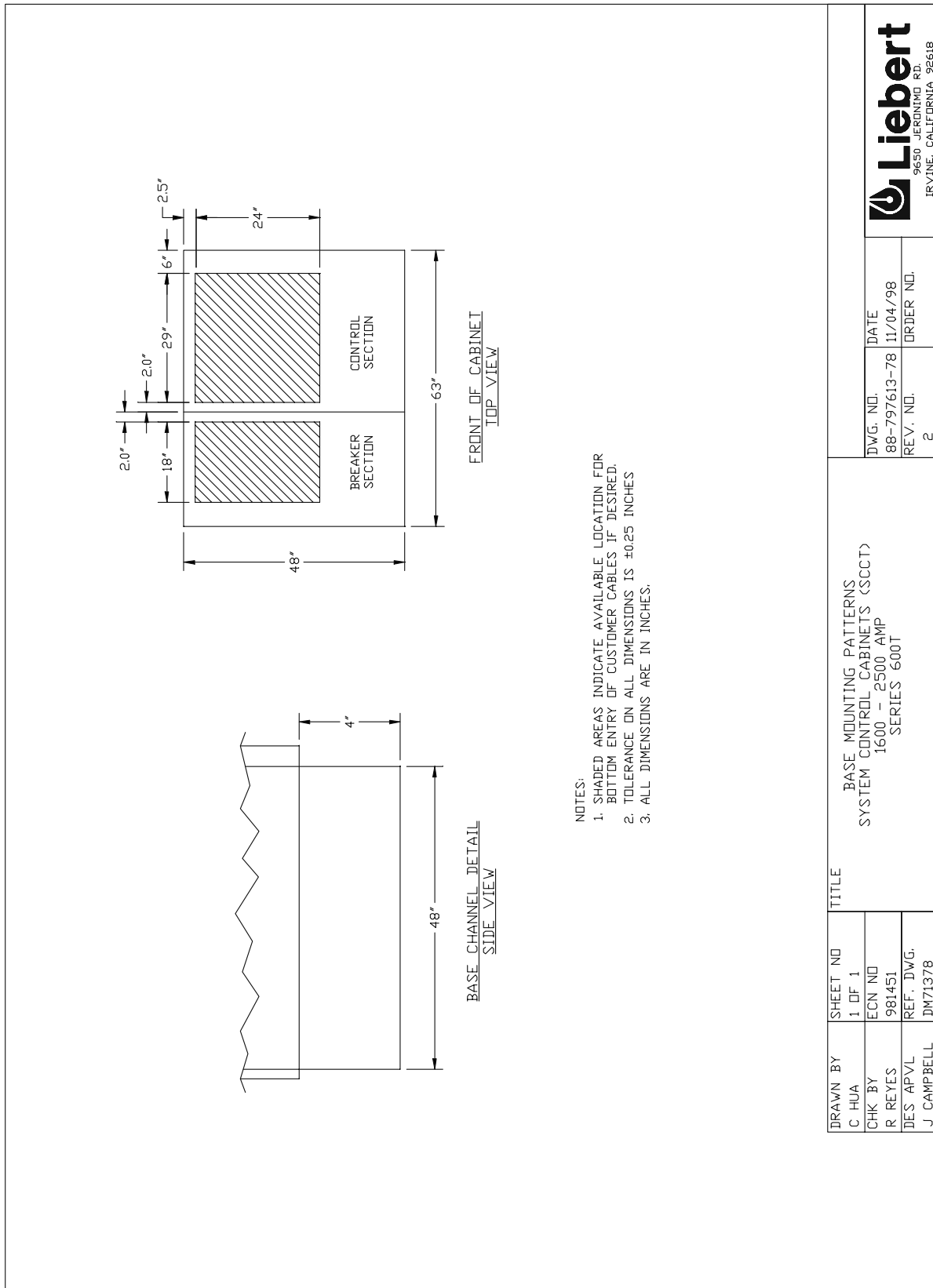

DRAWN BY C HUA		SHEET NO 1 OF 1	TITLE BASE MOUNTING PATTERNS SYSTEM CONTROL CABINETS (SCCT)	
CHK BY R REYES		ECN NO 981451	1600 - 2500 AMP SERIES 600T	
DES' APVL J CAMPBELL		REF. DWG. DW71378	DWG. NO. 88-797613-78	DATE 11/04/98
			REV. NO. 2	ORDER NO.
			 9650 JERDING RD. IRVINE, CALIFORNIA 92618	
FILE NAME: DW71378.DWG				

Figure 24 Base Mounting Patterns (SCCT), 3000 Amps

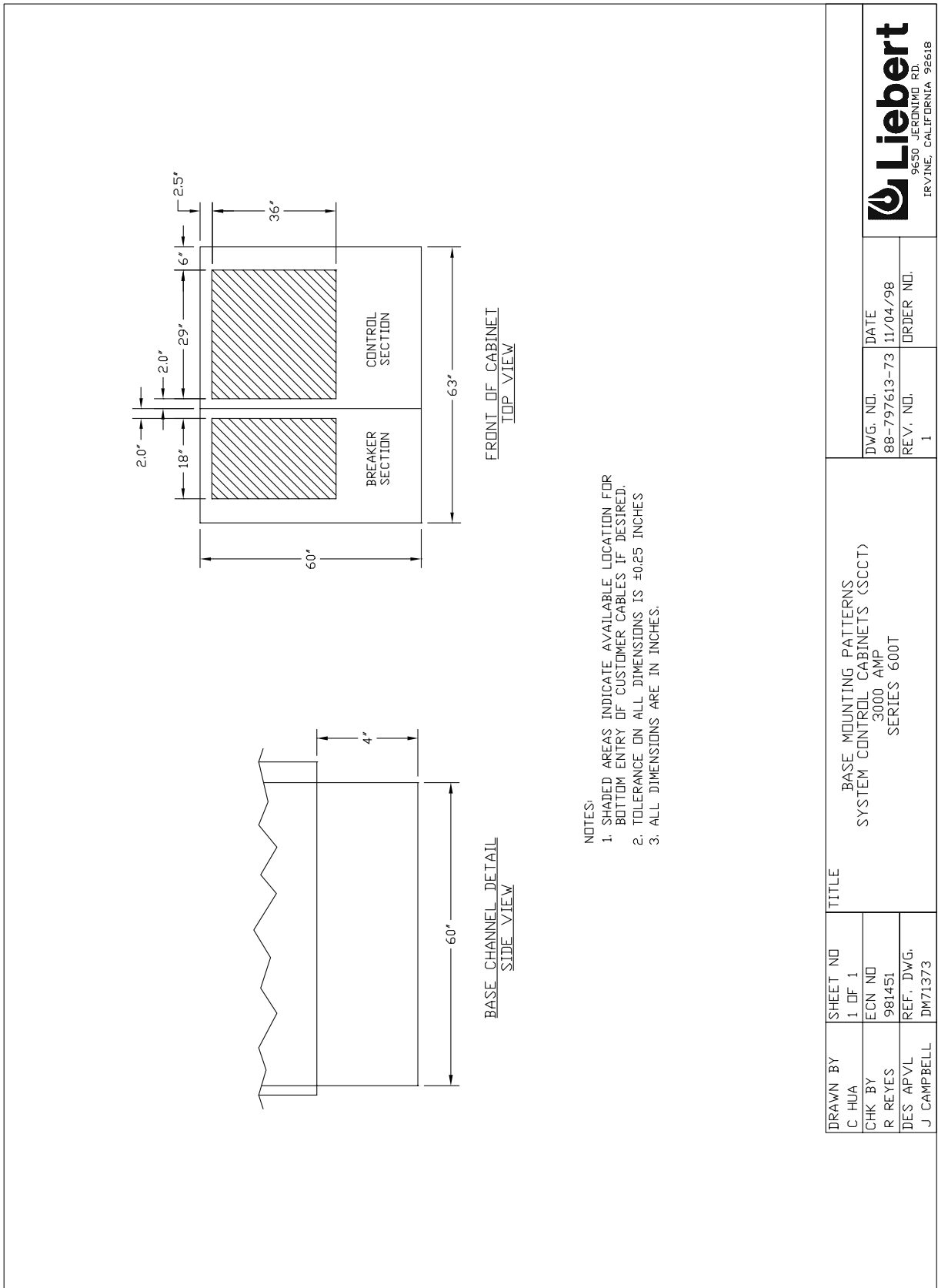
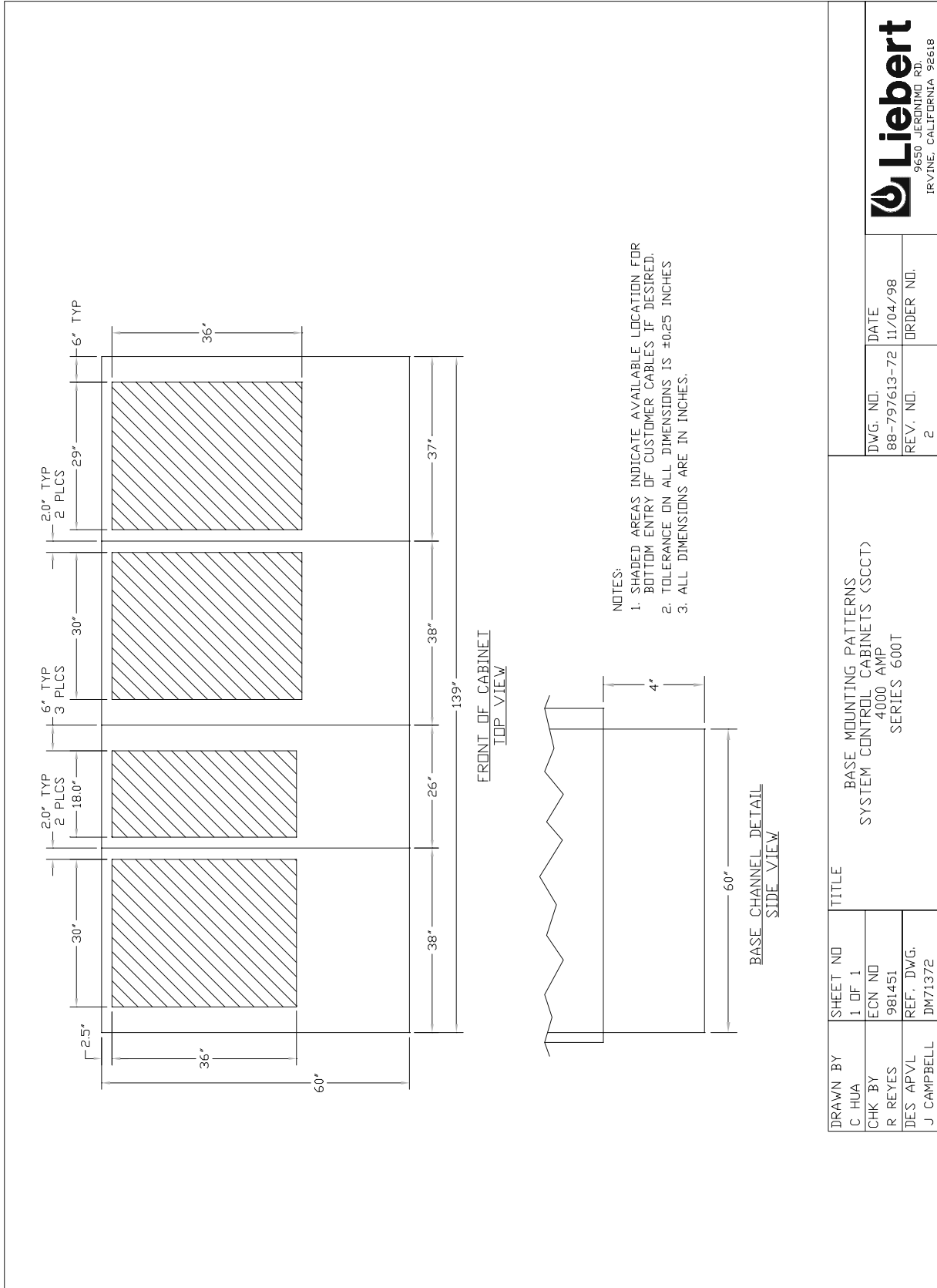

Figure 25 Base Mounting Patterns (SCCT), 4000 Amps



DRAWN BY C HUA	SHEET NO 1 OF 1	TITLE BASE MOUNTING PATTERNS SYSTEM CONTROL CABINETS (SCCT) 4000 AMP SERIES 600T		DWG. NO. 88-797613-72	DATE 11/04/98
CHK BY R REYES	ECN NO 981451			REV. NO. 2	ORDER NO.
DES APVL J CAMPBELL	REF. DWG. DM71372			FILE NAME: DM71372.DWG	



Figure 26 Shipping Split Detail, 500 kVA Multi-Module UPS, 12-Pulse Rectifier

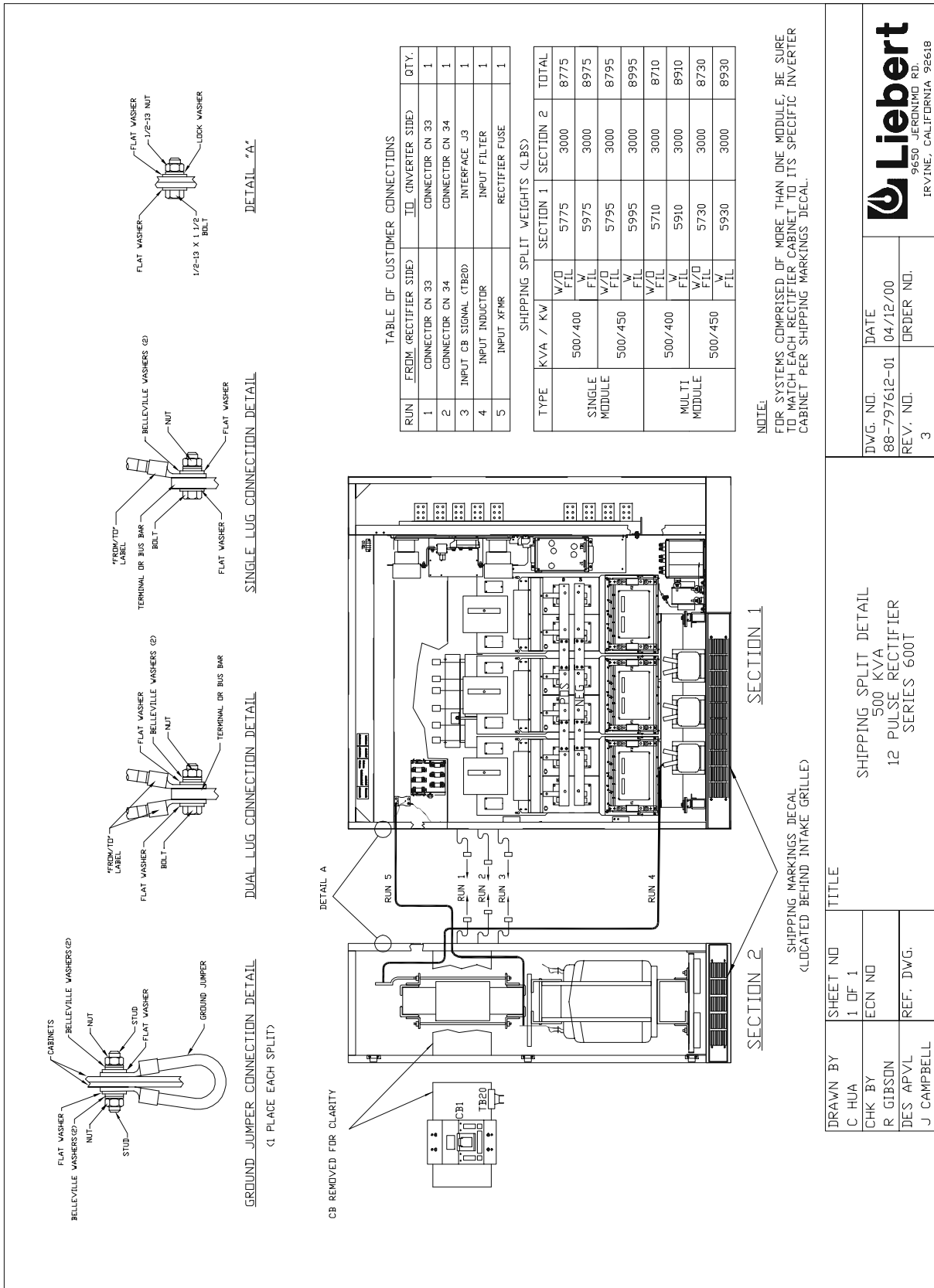

**Libert**  
 9650 JERONIMO RD.  
 IRVINE, CALIFORNIA 92618

DWG. NO. 88-797612-01  
 DATE 04/12/00  
 REV. NO. 3  
 ORDER NO.

**TITLE**  
 SHIPPING SPLIT DETAIL  
 500 KVA  
 12 PULSE RECTIFIER  
 SERIES 600T

**DRAWN BY** C HUA  
**CHK BY** R GIBSON  
**DES APVL** J CAMPBELL  
**SHEET NO** 1 OF 1  
**ECN NO**  
**REF. DWG.**

Figure 27 Shipping Split Detail, 625-750 kVA Multi-Module UPS, 6-Pulse Rectifier

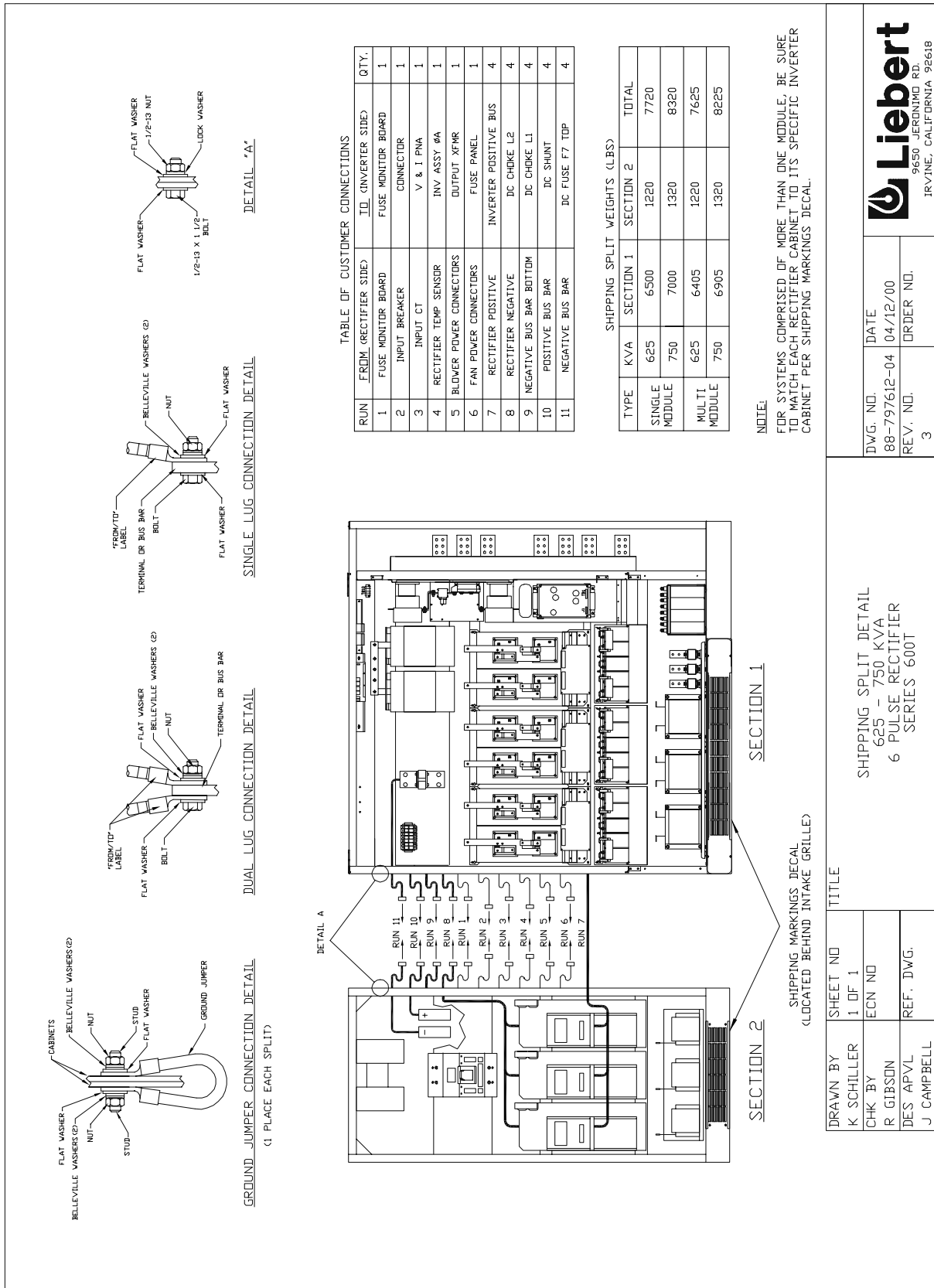
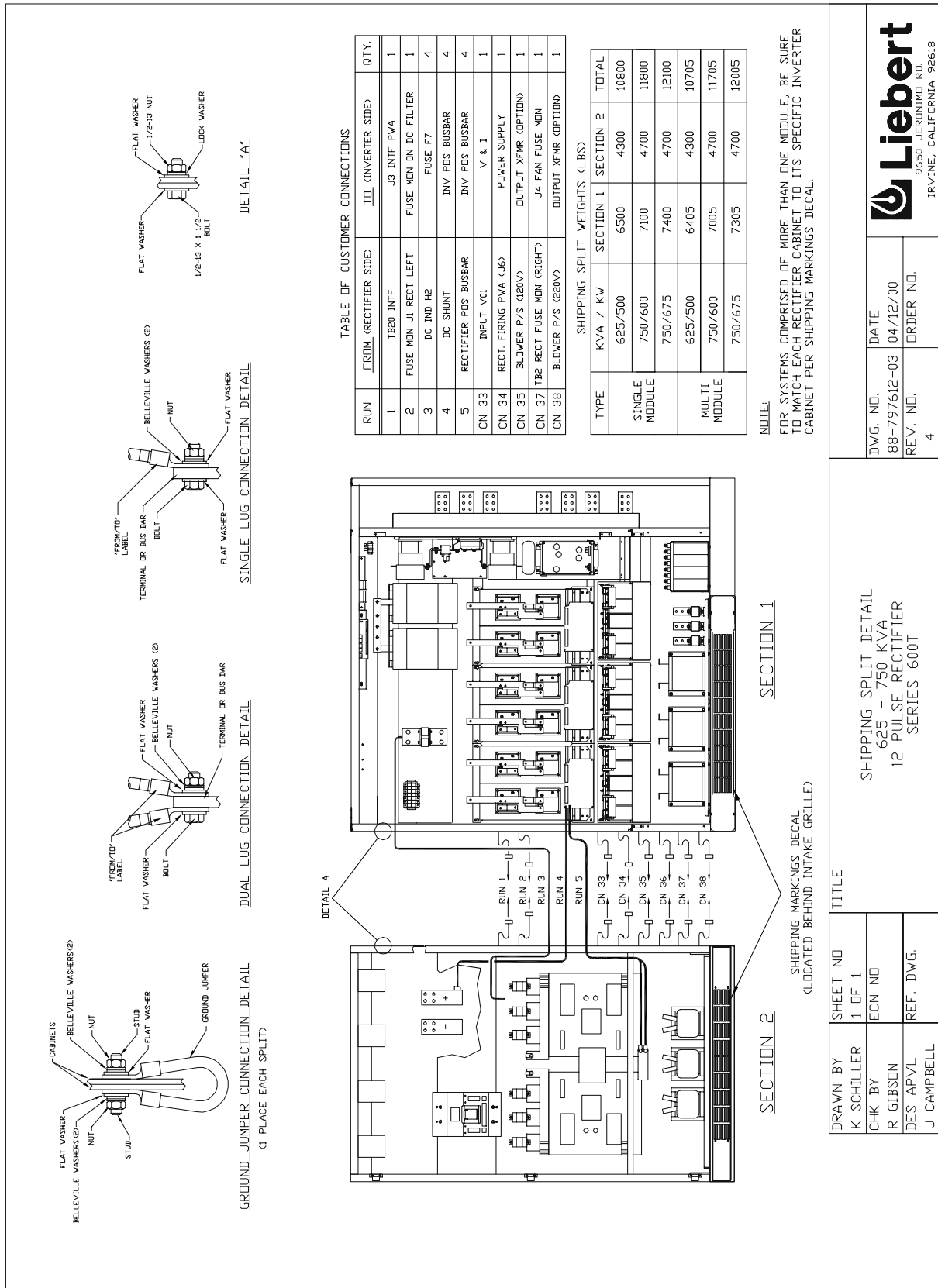

Figure 28 Shipping Split Detail, 625-750 kVA Multi-Module UPS, 12-Pulse Rectifier



DWG. NO. 88-797612-03  
DATE 04/12/00  
REV. NO. ORDER NO.  
4

FILE NAME: 88-797612-03-04.DWG

**DRAWN BY** K SCHILLER  
**CHK BY** R GIBSON  
**DES APVL** J CAMPBELL

**SHEET NO** 1 OF 1  
**ECN NO**  
**REF. DWG.**

**TITLE**  
SHIPPING SPLIT DETAIL  
625 - 750 KVA  
12 PULSE RECTIFIER  
SERIES 600T

Figure 29 Terminal Details, 500 kVA Module, 6-Pulse Rectifier

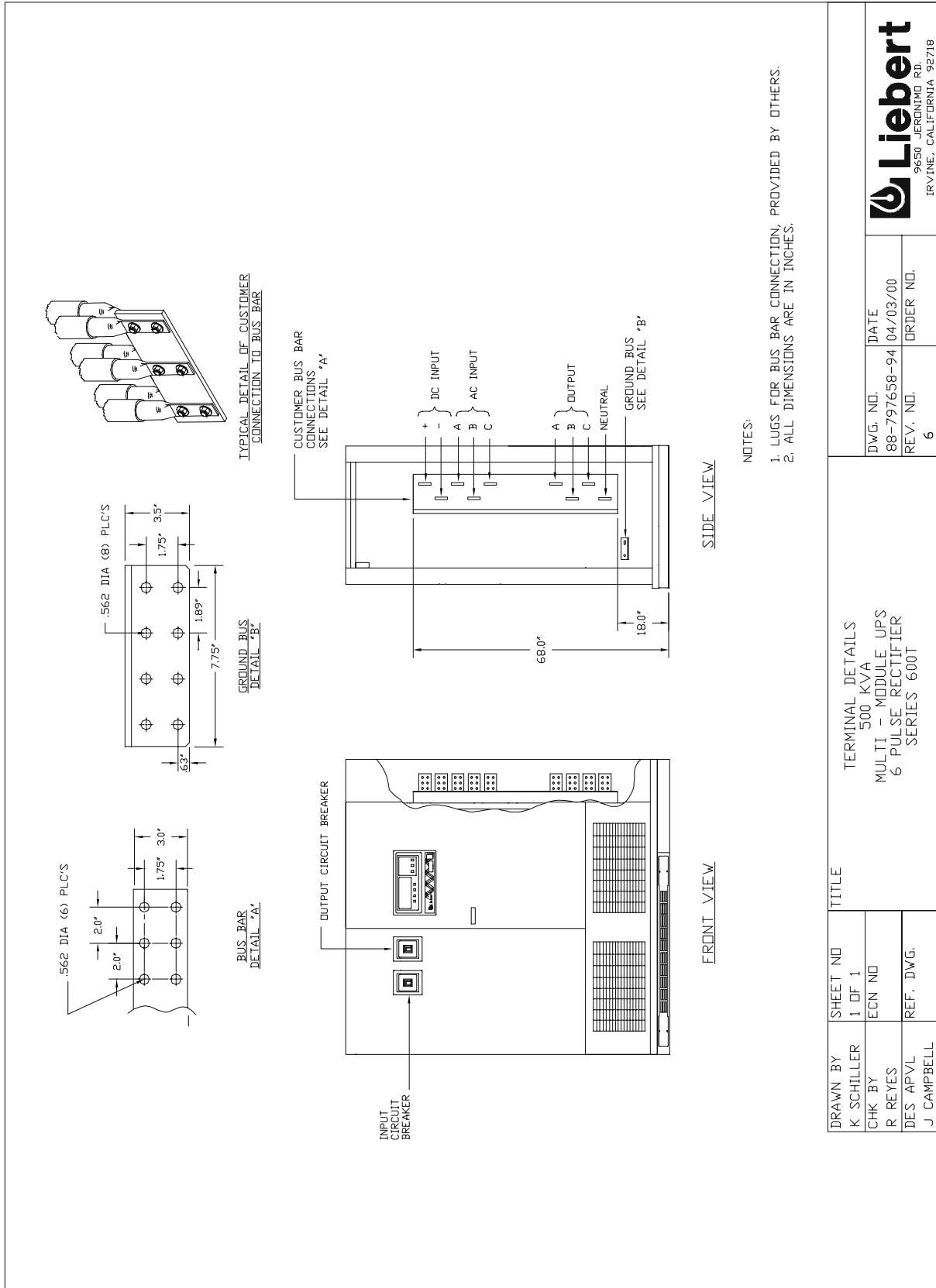
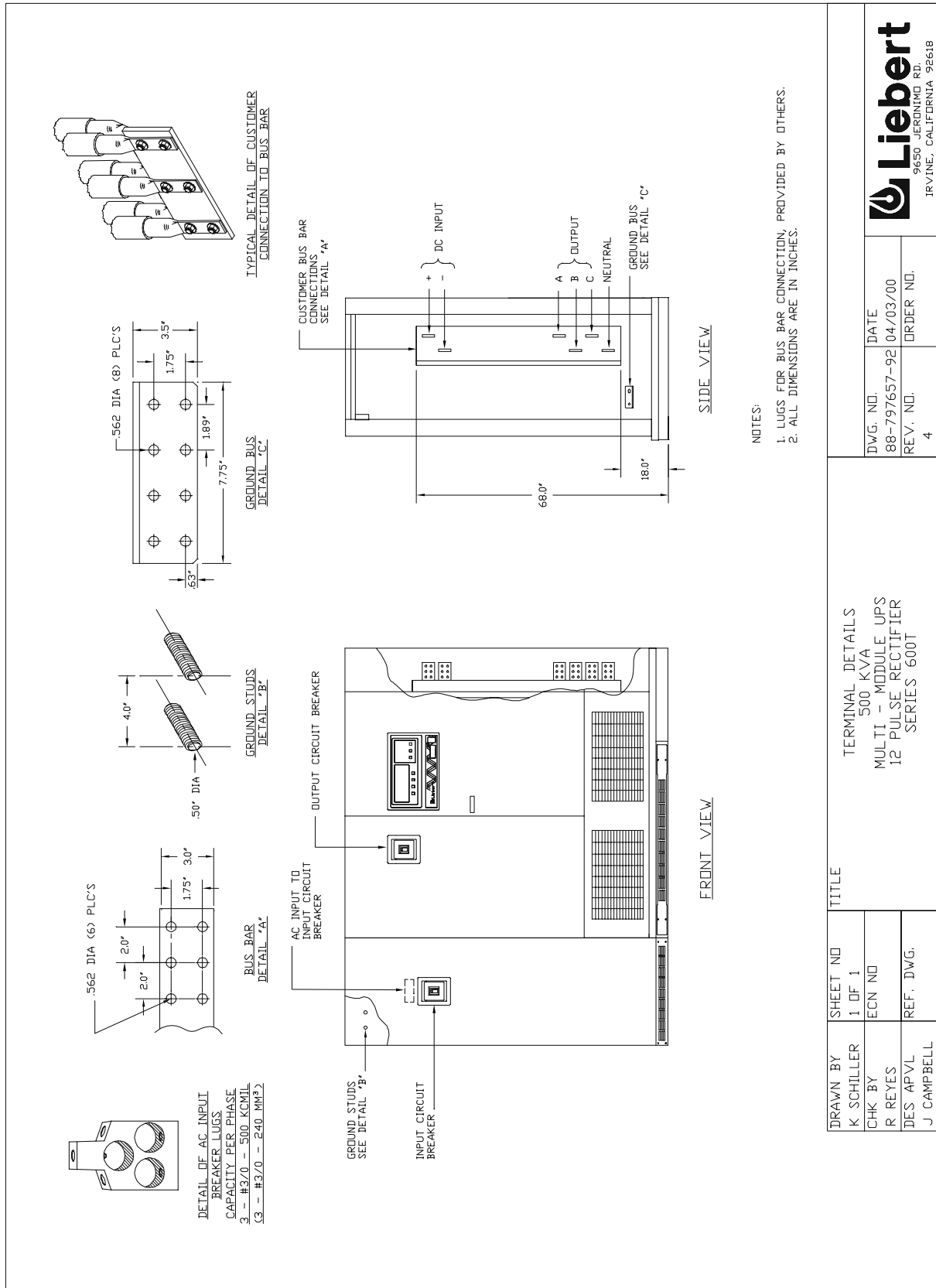

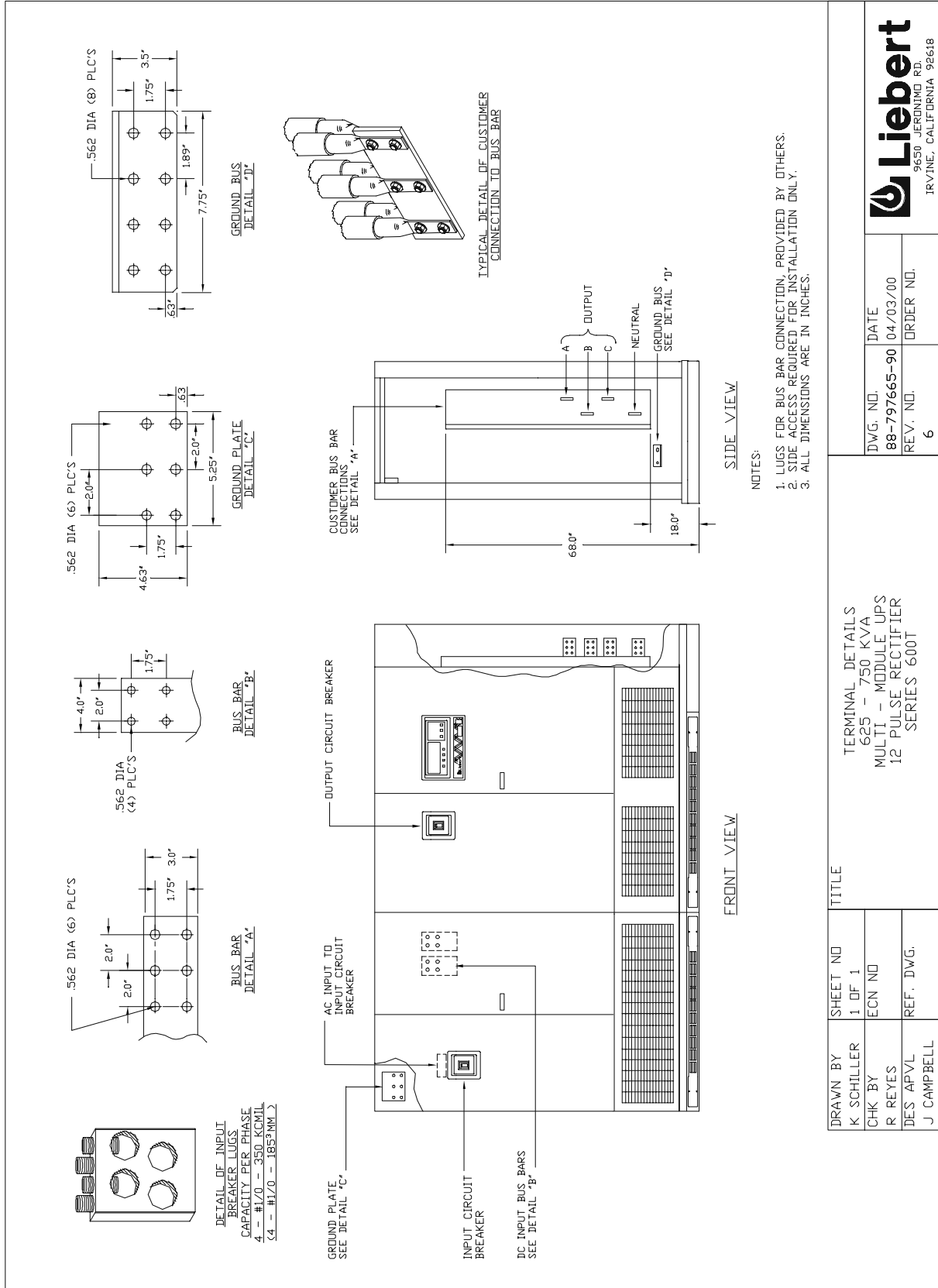

Figure 30 Terminal Details, 500 kVA Module, 12-Pulse Rectifier



DRAWN BY K SCHILLER		SHEET NO 1 OF 1		TITLE TERMINAL DETAILS	
CHK BY R REYES		ECN NO		500 KVA MODULE UPS 12 PULSE RECTIFIER SERIES 600T	
DES APVL J CAMPBELL		REF. DWG.		DWG. NO. 88-797657-92	DATE 04/03/00
				REV. NO. 4	ORDER NO.
				 9650 JERONIMO RD. IRVINE, CALIFORNIA 92618	
				FILE NAME: 88-797657-92-04.DWG	

Figure 31 Terminal Details, 625 & 750 kVA Modules, 6-Pulse and 12-Pulse



DRAWN BY K SCHILLER		SHEET NO 1 OF 1		TITLE TERMINAL DETAILS 625 - 750 KVA MULTI - MODULE UPS 12 PULSE RECTIFIER SERIES 600T	
CHK BY R REYES	ECN NO	DWG. NO. 88-797665-90	DATE 04/03/00	REV. NO.	ORDER NO.
DES APVL J CAMPBELL	REF. DWG.	6		FILE NAME: 88-797665-90-06.DWG	
			 9650 JERONIMO RD. IRVINE, CALIFORNIA 92618		

Figure 32 Terminal Details, 750 kVA/675 kW Std. and 750 kVA/600 kW with Optional Input Bus Bars



**Figure 33 Control Wiring, External Interconnections, Standard UPS Module**

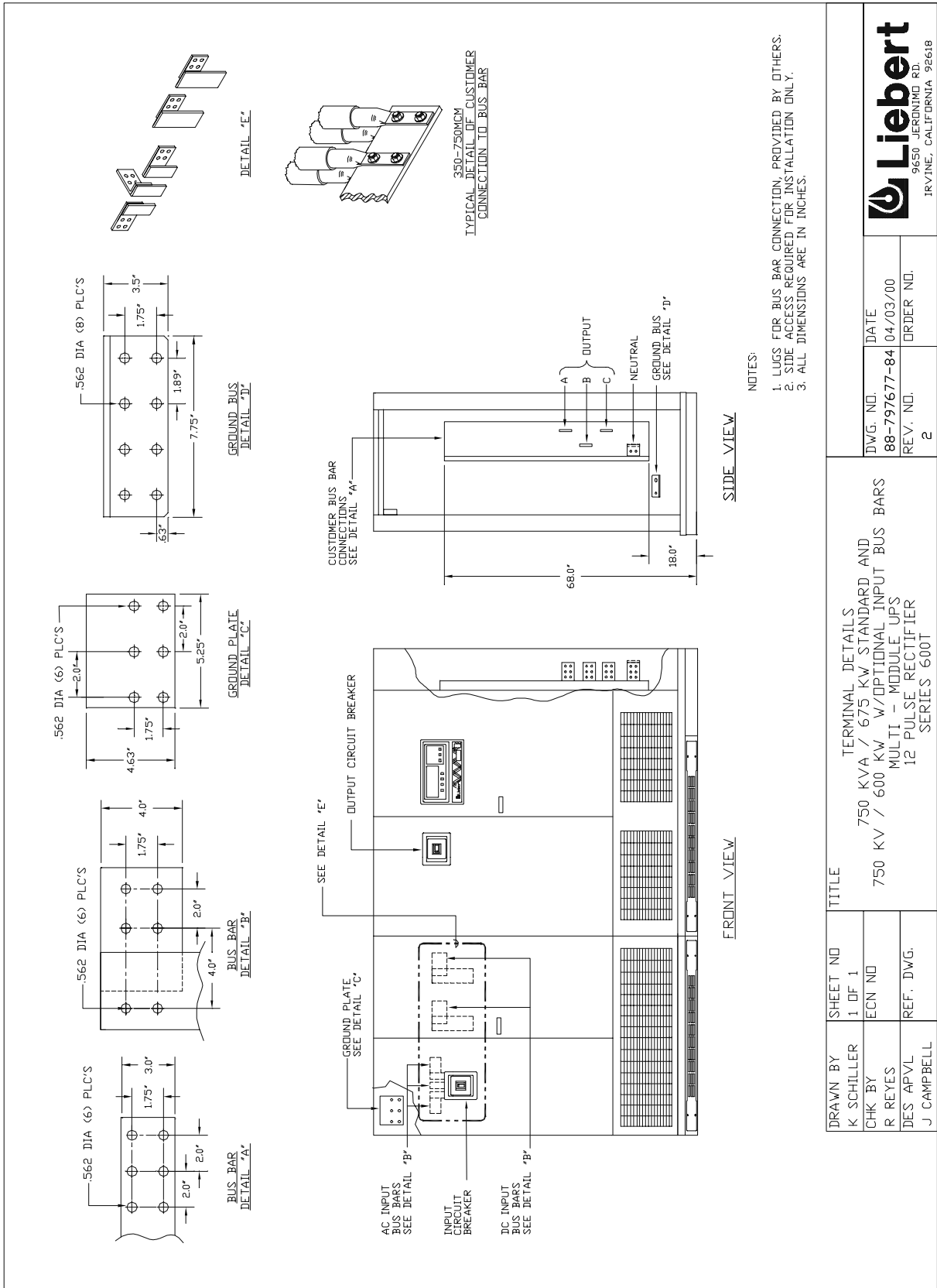
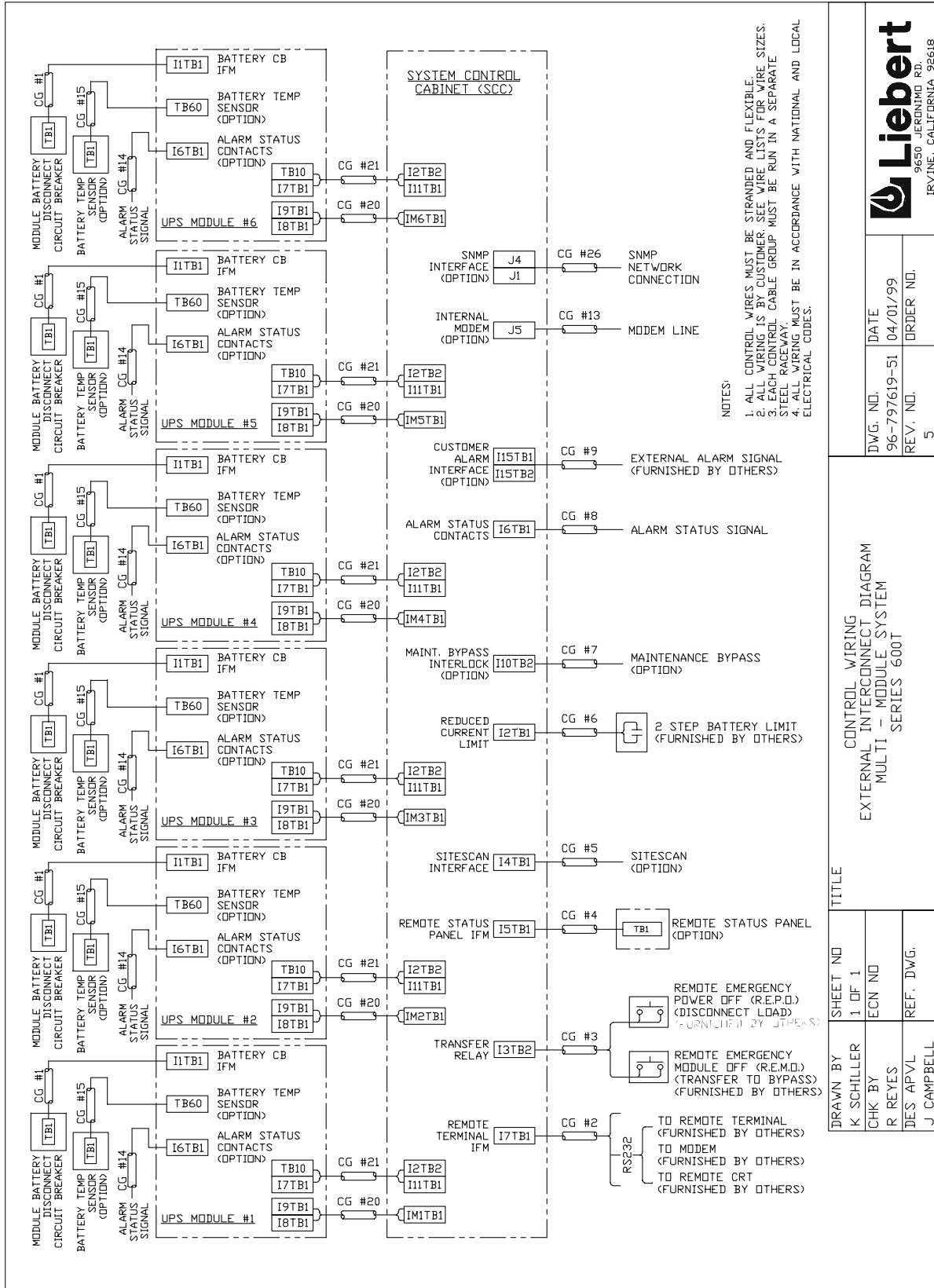

DWG. NO.	DATE
96-797619-51	04/01/99
REV. NO.	ORDER NO.
5	

CONTROL WIRING  
EXTERNAL INTERCONNECT DIAGRAM  
MULTI - MODULE SYSTEM  
SERIES 600T

SHEET NO	TITLE
1 OF 1	
ECN NO	
REF. DWG.	

DRAWN BY	J CAMPBELL
CHK BY	R REYES
DES APVL	

Figure 34 Control Connection Location, 500 kVA Modules

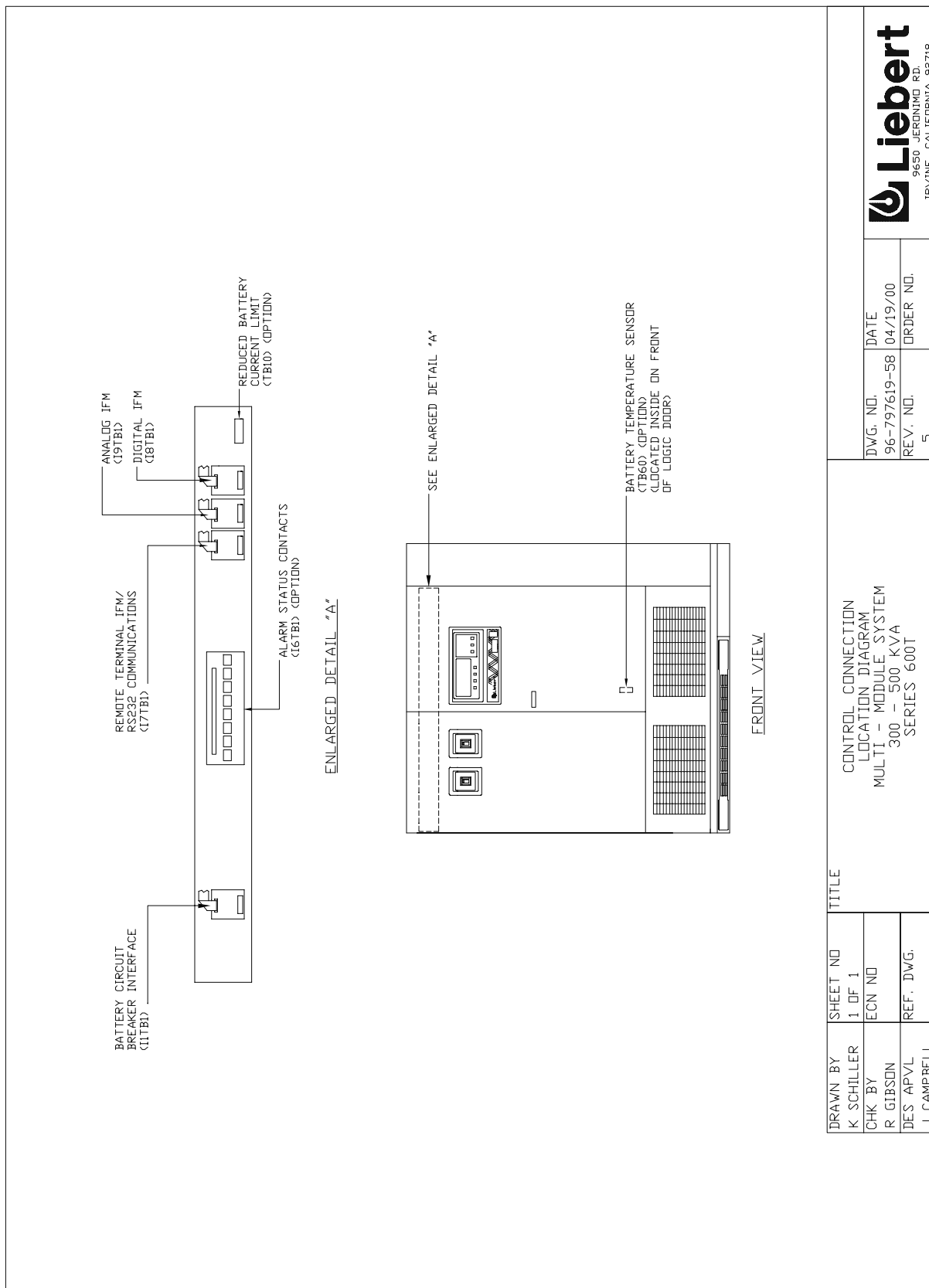

DRAWN BY K SCHILLER		SHEET NO 1 OF 1		TITLE	
CHK BY R GIBSON		ECN NO		CONTROL CONNECTION LOCATION DIAGRAM	
DES APVL J CAMPBELL		REF. DWG.		MULTI - MODULE SYSTEM 300 - 500 KVA SERIES 600T	
DWG. NO. 96-797619-58		DATE 04/19/00		ORDER NO.	
REV. NO. 5		FILE NAME: 96-797619-58-05.DWG			

Figure 35 Control Connection Location Diagram, 625 & 750 kVA Modules

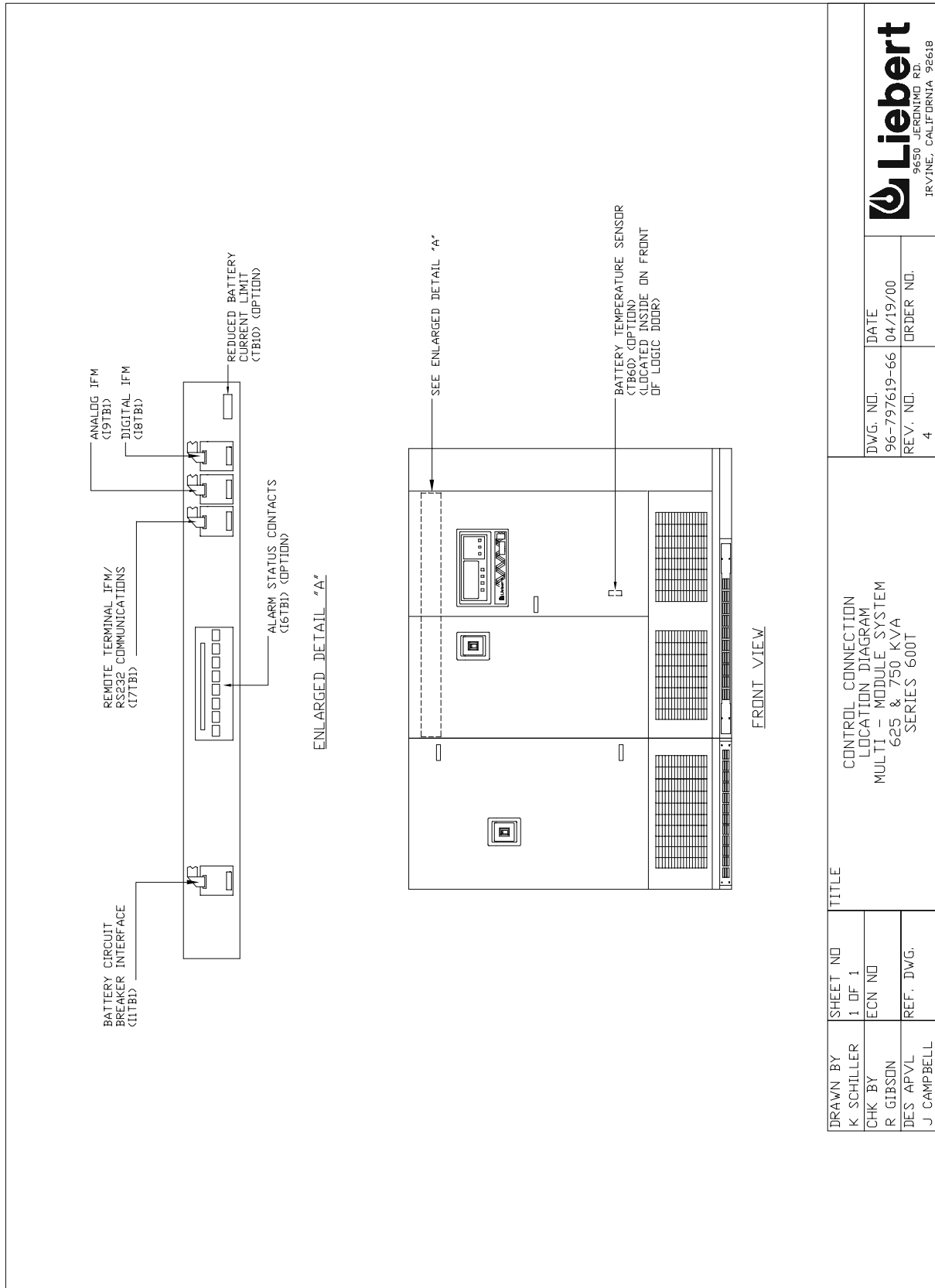

DRAWN BY K SCHILLER	SHEET NO 1 OF 1	TITLE CONTROL CONNECTION LOCATION DIAGRAM	DWG. NO. 96-797619-66	DATE 04/19/00
CHK BY R GIBSON	ECN NO	MULTI - MODULE SYSTEM 625 & 750 KVA	REV. NO.	ORDER NO.
DES APVL J CAMPBELL	REF. DWG.	SERIES 600T	4	
			FILE NAME: 96-797619-66-04.DWG	
			 9650 JERDIND RD. IRVINE, CALIF ORNIA 95618	

Figure 36 Control Connection Location Diagram, SCCC & SCCI

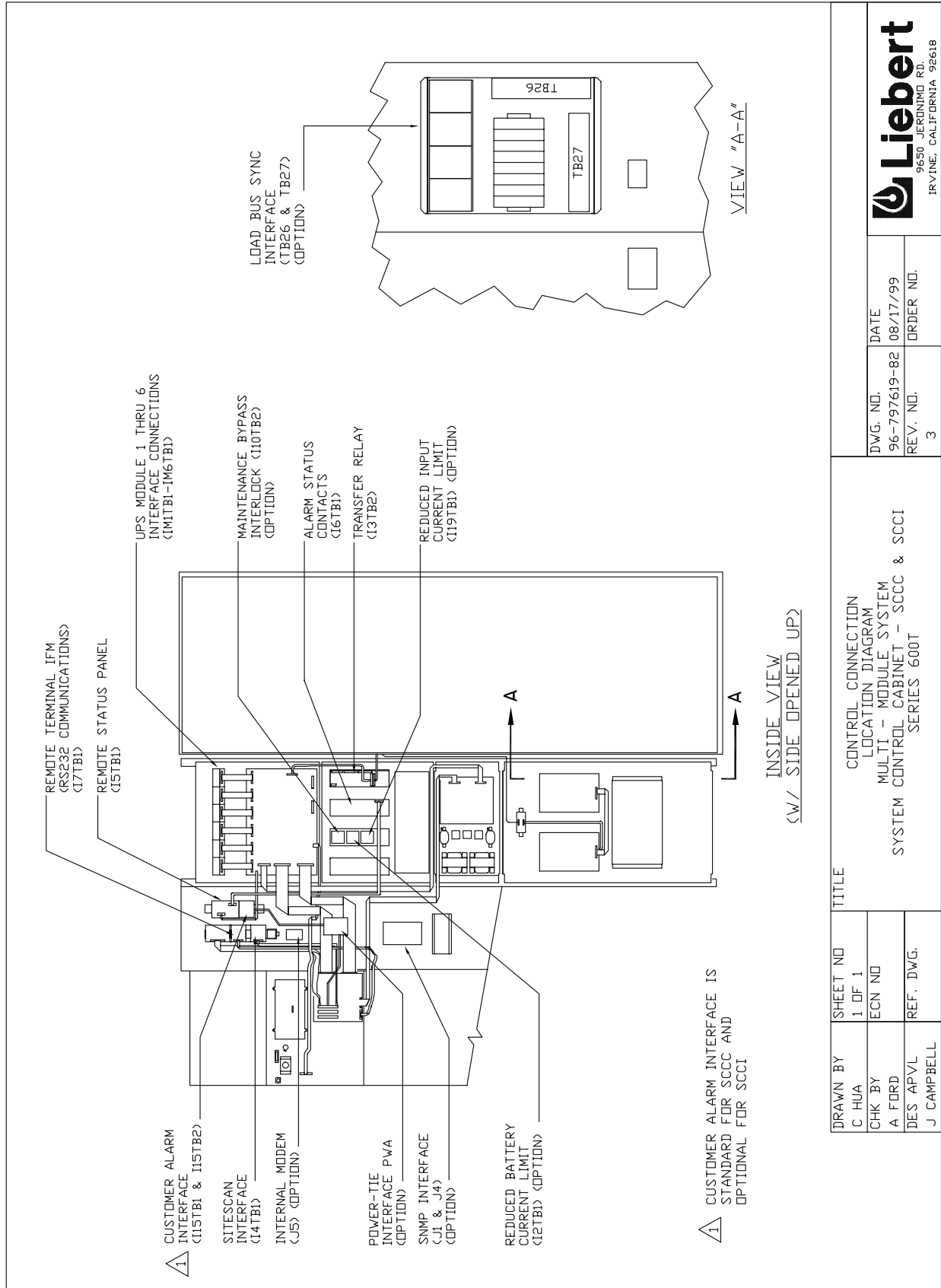

DRAWN BY C HUA		SHEET NO 1 OF 1		DWG. NO. 96-797619-82		DATE 08/17/99	
CHK BY A FORD		ECN NO		REV. NO. 3		ORDER NO.	
DES APV/L J CAMPBELL		REF. DWG.		TITLE CONTROL CONNECTION LOCATION DIAGRAM MULTI-MODULE SYSTEM SYSTEM CONTROL CABINET - SCCC & SCCI SERIES 600T			
<p style="text-align: right;">                   9650 JEROME RD.                  IRVINE, CALIFORNIA 92618             </p>							

Figure 37 Control Connection Location Diagram, SCCT

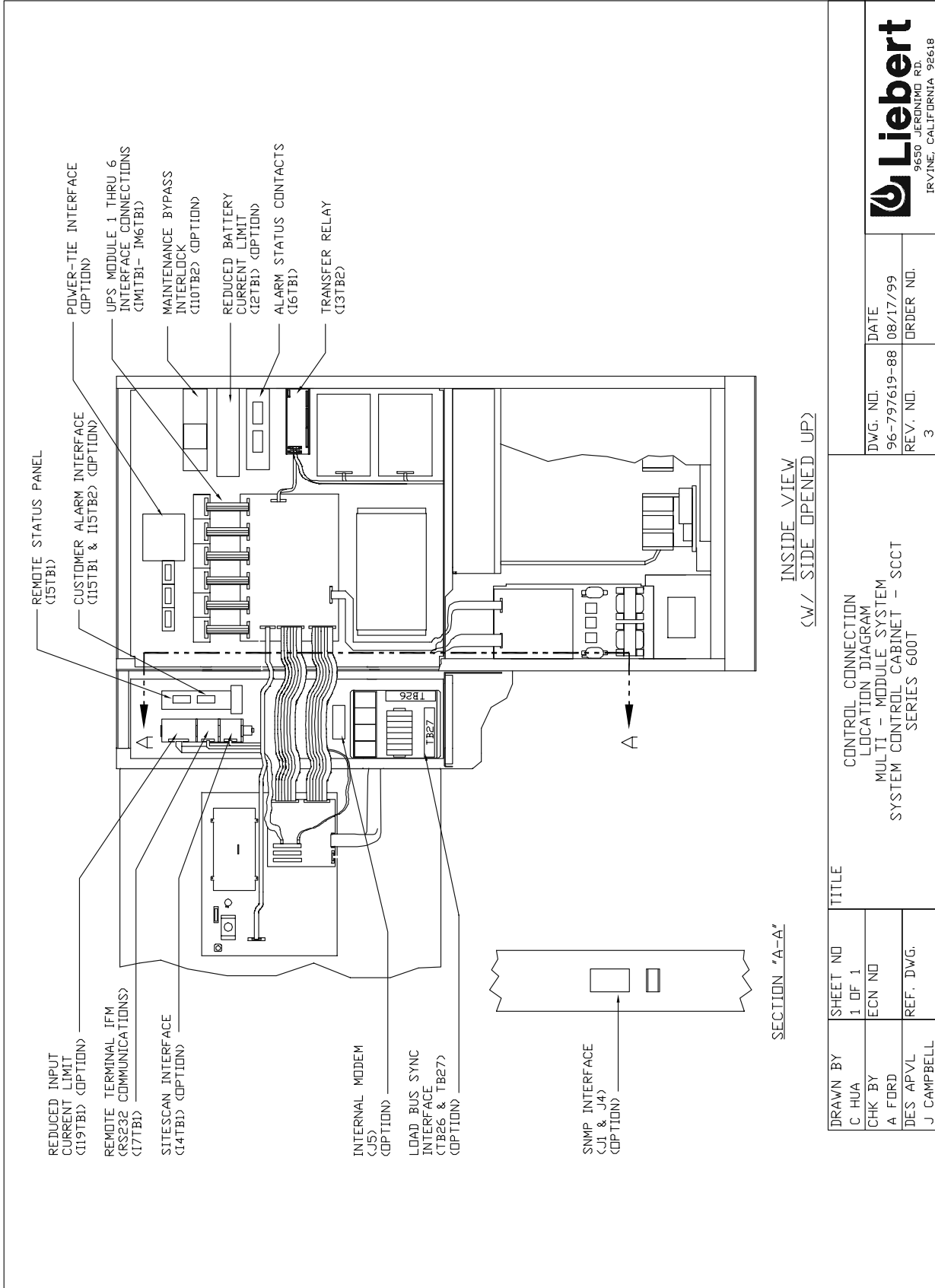



**Figure 38 Control Wire List, External Interconnections, Standard UPS Module**

WIRE NO.	TERMINAL DESIGNATION		SIGNAL NAME	MAXIMUM VOLTAGE	MAXIMUM CURRENT	COLOR	WIRE SIZE & TYPE	MAX. LENGTH	REMARKS
	FROM	TO							
	CABLE GROUP #1 (BATTERY CB IFM) FROM I1 IN UPS MODULE TO TB1 ON MODULE BATTERY DISCONNECT (MBD)								
901	I1TB1-1	TB1-1	TRIP SIGNAL (+)	+ 24VDC	100mA				
902	I1TB1-2	TB1-2	TRIP SIGNAL (-)	- 24VDC	100mA		1/C #14 (2.5 mmsq)	500 FT. (150 METERS)	
903	I1TB1-7	TB1-7	AUX COMM.	24VDC	100mA				
904	I1TB1-8	TB1-8	AUX N.D.	24VDC	100mA				

**NOTES:**

- EACH CABLE GROUP MUST BE RUN IN A SEPARATE STEEL RACEWAY TO PREVENT CONTROL SIGNAL INTERFERENCE.
- REFER TO UPS MODULE CONTROL CONNECTION LOCATION DIAGRAM FOR LOCATION OF WIRING CONNECTIONS.
- FOR OPTION WIRING CONNECTIONS, REFER TO INDIVIDUAL CONTROL WIRE LISTS.
- ALL EXTERNAL WIRE FURNISHED BY OTHERS.
- N.D. = NORMALLY OPEN, COMM. = COMMON.
- ALL WIRING MUST BE IN ACCORDANCE WITH NATIONAL AND LOCAL ELECTRICAL CODES.



9650 JERONIMO RD.  
IRVINE, CALIFORNIA 92618

DRAWN BY C HUA	SHEET NO 1 OF 1	TITLE CONTROL WIRE LIST EXTERNAL INTERCONNECTIONS STANDARD WIRING MULTI - MODULE SYSTEM - UPS MODULE SERIES 600T	DWG. NO. 96-797619-60	DATE 08/23/00
CHK BY R REYES	ECN NO		REV. NO. 5	ORDER NO.
DES APVL J CAMPBELL	REF. DWG.			

FILE NAME: 96-797619-60-03.DWG

Figure 39 Control Wire List, External Interconnections, System Control Cabinet, Part 1 of 3

WIRE NO.	TERMINAL DESIGNATION		SIGNAL NAME	MAXIMUM VOLTAGE	MAXIMUM CURRENT	COLOR	WIRE SIZE & TYPE	MAX. LENGTH	REMARKS	
	FROM	TO								
CABLE GROUP #2 (REMOTE TERMINAL IFM - RS232) FROM I7 IN SYSTEM CONTROL CABINET TO CUSTOMER CONNECTION (F.B.D)										
700	I7TB1-1	F.B.D.	REM. TERM. T X D	24VDC	100mA		3/C #22 (0.50 mmsq) TWISTED SHIELDED	100 FT. (30 METERS)	BELDEN 9939 OR EQUAL SEE NOTE 2	
701	I7TB1-2	F.B.D.	REM. TERM. R X D	24VDC	100mA					
702	I7TB1-3	F.B.D.	REM. TERM. GND	24VDC	100mA					
---	I7TB1-4	F.B.D.	REM. TERM. SHD	24VDC	100mA					
703	I7TB1-6	F.B.D.	MODEM DCD	24VDC	100mA					
704	I7TB1-7	F.B.D.	MODEM T X D	24VDC	100mA					
705	I7TB1-8	F.B.D.	MODEM R X D	24VDC	100mA					
706	I7TB1-9	F.B.D.	MODEM GND	24VDC	100mA					
---	I7TB1-10	F.B.D.	MODEM SHD	24VDC	100mA					
707	I7TB1-11	F.B.D.	REM. CRT T X D	24VDC	100mA					
708	I7TB1-12	F.B.D.	REM. CRT GND	24VDC	100mA					
---	I7TB1-13	F.B.D.	REM. CRT SHD	24VDC	100mA					
CABLE GROUP #3 (TRANSFER RELAY) FROM I3 IN SYSTEM CONTROL CABINET TO R.E.M.D. & R.E.P.D.										
711	I3TB2-1	N.D.	REMOTE EMER. MOD. OFF	24VDC	1A			500 FT. (150 METERS)		
712	I3TB2-2	COMM.	REMOTE EMER. MOD. OFF	24VDC	1A		1/C #14 (2.5 mmsq)			
713	I3TB2-3	N.D.	REMOTE EMER. POWER OFF	24VDC	1A					
714	I3TB2-4	COMM.	REMOTE EMER. POWER OFF	24VDC	1A					

NOTES:

1. EACH CABLE GROUP MUST BE RUN IN A SEPARATE STEEL RACEWAY TO PREVENT CONTROL SIGNAL INTERFERENCE.
2. CABLE GROUP #2 AND #5 MAY BE RUN IN THE SAME CONDUIT.
3. REFER TO SCC CONTROL CONNECTION LOCATION DIAGRAM FOR LOCATION OF WIRING CONNECTIONS.
4. FOR OPTION WIRING CONNECTIONS, REFER TO INDIVIDUAL CONTROL WIRE LISTS.
5. F.B.D. - FURNISHED BY OTHERS.
6. ALL EXTERNAL WIRE FURNISHED BY OTHERS.
7. N.D. = NORMALLY OPEN, COMM. = COMMON.
8. ALL WIRING MUST BE IN ACCORDANCE WITH NATIONAL AND LOCAL ELECTRICAL CODES.

DRAWN BY C HUA	SHEET NO 1 OF 1	TITLE CONTROL WIRE LIST	
	CHK BY R REYES	ECN NO	EXTERNAL INTERCONNECTIONS
DES APVL J CAMPBELL	REF. DWG.	REV. NO. 5	DATE 08/23/00
		DWG. NO. 96-797619-19	ORDER NO. 08/23/00
		SYSTEM CONTROL CABINET - PART 1 OF 3	
		SERIES 600T	



FILE NAME: 96-797619-19-05.DWG

Figure 40 Control Wire List, External Interconnections, Standard System Control Cabinet, Part 2 of 3

WIRE NO.	TERMINAL DESIGNATION		SIGNAL NAME	MAXIMUM VOLTAGE	MAXIMUM CURRENT	COLOR	WIRE SIZE & TYPE	MAX. LENGTH	REMARKS
	FROM	TO							
CABLE GROUP #5 (SITESCAN INTERFACE BOARD) FROM I4 IN SYSTEM CONTROL CABINET TO OPTIONAL SITESCAN									
741	I4TB1-1	SITESCAN	SITESCAN SCC (+)	5VDC	10mA	BLACK	2/C #22 (0.50 mm <sup>2</sup> ) TWISTED PAIR	1000 FT. (300 METERS)	BELDEN 8761 OR EQUAL SEE NOTE 2
742	I4TB1-2	SITESCAN	SITESCAN SCC (-)	5VDC	10mA	CLEAR			
743	I4TB1-3	SITESCAN	SITESCAN MOD1 (+)	5VDC	10mA	BLACK			
744	I4TB1-4	SITESCAN	SITESCAN MOD1 (-)	5VDC	10mA	CLEAR			
745	I4TB1-5	SITESCAN	SITESCAN MOD2 (+)	5VDC	10mA	BLACK			
746	I4TB1-6	SITESCAN	SITESCAN MOD2 (-)	5VDC	10mA	CLEAR			
747	I4TB1-7	SITESCAN	SITESCAN MOD3 (+)	5VDC	10mA	BLACK			
748	I4TB1-8	SITESCAN	SITESCAN MOD3 (-)	5VDC	10mA	CLEAR			
749	I4TB1-9	SITESCAN	SITESCAN MOD4 (+)	5VDC	10mA	BLACK			
750	I4TB1-10	SITESCAN	SITESCAN MOD4 (-)	5VDC	10mA	CLEAR			
751	I4TB1-11	SITESCAN	SITESCAN MOD5 (+)	5VDC	10mA	BLACK			
752	I4TB1-12	SITESCAN	SITESCAN MOD5 (-)	5VDC	10mA	CLEAR			
753	I4TB1-13	SITESCAN	SITESCAN MOD6 (+)	5VDC	10mA	BLACK			
754	I4TB1-14	SITESCAN	SITESCAN MOD6 (-)	5VDC	10mA	CLEAR			
CABLE GROUP #6 (REDUCED CURRENT LIMIT) FROM I2 IN SYSTEM CONTROL CABINET TO CUSTOMER CONNECTION (F.B.O.)									
761	I2TB1-3	N.D.	2 STEP BATTERY LIMIT	24VDC	100mA		1/C #14 (2.5 mm <sup>2</sup> )	500 FT. (150 METERS)	
762	I2TB1-4	COMM.	2 STEP BATTERY LIMIT	24VDC	100mA				

NOTES:

- EACH CABLE GROUP MUST BE RUN IN A SEPARATE STEEL RACEWAY TO PREVENT CONTROL SIGNAL INTERFERENCE.
- CABLE GROUP #2 AND #5 MAY BE RUN IN THE SAME CONDUIT.
- REFER TO SCC CONTROL CONNECTION LOCATION DIAGRAM FOR LOCATION OF WIRING CONNECTIONS.
- FOR OPTION WIRING CONNECTIONS, REFER TO INDIVIDUAL CONTROL WIRE LISTS.
- F.B.O. - FURNISHED BY OTHERS.
- ALL EXTERNAL WIRE FURNISHED BY OTHERS.
- N.D. = NORMALLY OPEN, COMM. = COMMON.
- ALL WIRING MUST BE IN ACCORDANCE WITH NATIONAL AND LOCAL ELECTRICAL CODES.

DRAWN BY C HUA	SHEET NO 1 OF 1	TITLE	
		CONTROL WIRE LIST EXTERNAL INTERCONNECTIONS STANDARD WIRING MULTI - MODULE SYSTEM SYSTEM CONTROL CABINET - PART 2 OF 3 SERIES 600T	
CHK BY R REYES	ECN NO	DWG. NO. 96-797619-20	DATE 08/23/00
DES APVL J CAMPBELL	REF. DWG.	REV. NO. 5	ORDER NO.



FILE NAME: 96-797619-20-03.DWG

**Figure 41 Control Wire List, External Interconnections, Standard System Control Cabinet, Part 3 of 3**

WIRE NO.	TERMINAL DESIGNATION		SIGNAL NAME	MAXIMUM VOLTAGE	MAXIMUM CURRENT	COLOR	WIRE SIZE & TYPE	MAX. LENGTH	REMARKS
	FROM	TO							
CABLE GROUP #8 (ALARM STATUS CONTACTS) FROM I6 IN SYSTEM CONTROL CABINET TO CUSTOMER CONNECTION (F.B.D.)									
801	I6TBI-1	N.D.	LOAD ON UPS	125VAC	500mA				
802	I6TBI-3	N.C.	LOAD ON UPS	125VAC	500mA				
803	I6TBI-5	COMM.	LOAD ON UPS	125VAC	500mA				
804	I6TBI-7	N.D.	LOAD ON BYPASS	125VAC	500mA				
805	I6TBI-9	N.C.	LOAD ON BYPASS	125VAC	500mA				
806	I6TBI-11	COMM.	LOAD ON BYPASS	125VAC	500mA				
807	I6TBI-13	N.D.	BATTERY DISCHARGING	125VAC	500mA				
808	I6TBI-15	N.C.	BATTERY DISCHARGING	125VAC	500mA				
809	I6TBI-17	COMM.	BATTERY DISCHARGING	125VAC	500mA				
810	I6TBI-19	N.D.	LOW BATTERY WARNING	125VAC	500mA				
811	I6TBI-21	N.C.	LOW BATTERY WARNING	125VAC	500mA				
812	I6TBI-23	COMM.	LOW BATTERY WARNING	125VAC	500mA				
813	I6TBI-25	N.D.	OVERLOAD	125VAC	500mA		1/2 #14 (2.5 mmsq)	500 FT. (150 METERS)	SEE NOTE 2
814	I6TBI-27	N.C.	OVERLOAD	125VAC	500mA				
815	I6TBI-29	COMM.	OVERLOAD	125VAC	500mA				
816	I6TBI-31	N.D.	AMBIENT OVERTEMP	125VAC	500mA				
817	I6TBI-33	N.C.	AMBIENT OVERTEMP	125VAC	500mA				
818	I6TBI-35	COMM.	AMBIENT OVERTEMP	125VAC	500mA				
819	I6TBI-37	N.D.	SYSTEM SUMMARY ALARM	125VAC	500mA				
820	I6TBI-39	N.C.	SYSTEM SUMMARY ALARM	125VAC	500mA				
821	I6TBI-41	COMM.	SYSTEM SUMMARY ALARM	125VAC	500mA				
822	I6TBI-43	N.D.	NEW ALARM	125VAC	500mA				
823	I6TBI-45	N.C.	NEW ALARM	125VAC	500mA				
824	I6TBI-47	COMM.	NEW ALARM	125VAC	500mA				

**NOTES:**

1. EACH CABLE GROUP MUST BE RUN IN A SEPARATE STEEL RACEWAY TO PREVENT CONTROL SIGNAL INTERFERENCE.
2. CABLE GROUP #8 AND #14 MAY BE RUN IN THE SAME CONDUIT.
3. REFER TO SCC CONTROL CONNECTION LOCATION DIAGRAM FOR LOCATION OF WIRING CONNECTIONS.
4. FOR OPTION WIRING CONNECTIONS REFER TO INDIVIDUAL CONTROL WIRE LISTS.
5. F.B.D. - FURNISHED BY OTHERS.
6. ALL EXTERNAL WIRE FURNISHED BY OTHERS.
7. N.D. = NORMALLY OPEN, N.C. = NORMALLY CLOSED, COMM. = COMMON.
8. ALL WIRING MUST BE IN ACCORDANCE WITH NATIONAL AND LOCAL ELECTRICAL CODES.

DRAWN BY C HUA	SHEET NO 1 OF 1	TITLE CONTROL WIRE LIST EXTERNAL INTERCONNECTIONS STANDARD WIRING MULTI - MODULE SYSTEM SYSTEM CONTROL CABINET - PART 3 OF 3 SERIES 600T		DWG. NO. 96-797619-21	DATE 08/23/00
CHK BY R REYES	ECN NO			REV. NO. 5	ORDER NO.
DES APVL J CAMPBELL	REF. DWG.				



FILE NAME: 96-797619-21-03.DWG

Figure 42 Control Wire List, External Interconnections, Alarm Status Contacts

WIRE NO.	TERMINAL DESIGNATION		SIGNAL NAME	MAXIMUM VOLTAGE	MAXIMUM CURRENT	COLOR	WIRE SIZE & TYPE	MAX. LENGTH	REMARKS
	FROM	TO							
CABLE GROUP #14 FROM I6 IN UPS MODULE TO CUSTOMER CONNECTION (F.B.O.)									
910	I6TB2-22	N.D.	OUTPUT CB OPEN	125VAC	500mA				
911	I6TB2-24	N.C.	OUTPUT CB OPEN	125VAC	500mA				
912	I6TB2-23	COMM.	OUTPUT CB OPEN	125VAC	500mA				
913	I6TB2-19	N.D.	BATTERY CB OPEN	125VAC	500mA				
914	I6TB2-21	N.C.	BATTERY CB OPEN	125VAC	500mA				
915	I6TB2-20	COMM.	BATTERY CB OPEN	125VAC	500mA				
916	I6TB2-16	N.D.	BATTERY DISCHARGING	125VAC	500mA				
917	I6TB2-18	N.C.	BATTERY DISCHARGING	125VAC	500mA				
918	I6TB2-17	COMM.	BATTERY DISCHARGING	125VAC	500mA				
919	I6TB2-13	N.D.	LDV BATTERY WARNING	125VAC	500mA				
920	I6TB2-15	N.C.	LDV BATTERY WARNING	125VAC	500mA				
921	I6TB2-14	COMM.	LDV BATTERY WARNING	125VAC	500mA				
922	I6TB2-10	N.D.	CONTROL FAILURE	125VAC	500mA				
923	I6TB2-12	N.C.	CONTROL FAILURE	125VAC	500mA				
924	I6TB2-11	COMM.	CONTROL FAILURE	125VAC	500mA				
925	I6TB2-7	N.D.	AMBIENT OVERTEMP	125VAC	500mA				
926	I6TB2-9	N.C.	AMBIENT OVERTEMP	125VAC	500mA				
927	I6TB2-8	COMM.	AMBIENT OVERTEMP	125VAC	500mA				
928	I6TB2-4	N.D.	MODULE SUMMARY ALARM	125VAC	500mA				
929	I6TB2-6	N.C.	MODULE SUMMARY ALARM	125VAC	500mA				
930	I6TB2-5	COMM.	MODULE SUMMARY ALARM	125VAC	500mA				
931	I6TB2-1	N.D.	NEW ALARM	125VAC	500mA				
932	I6TB2-3	N.C.	NEW ALARM	125VAC	500mA				
933	I6TB2-2	COMM.	NEW ALARM	125VAC	500mA				

NOTES:

- EACH CABLE GROUP MUST BE RUN IN A SEPARATE STEEL RACEWAY TO PREVENT CONTROL SIGNAL INTERFERENCE.
- CABLE GROUP #14 AND STANDARD SCC CABLE GROUP #8 MAY BE RUN IN THE SAME CONDUIT.
- THE CONTACTS ARE ALSO RATED 2A MAX. AT 30 VDC MAX.
- REFER TO UPS MODULE CONTROL CONNECTION LOCATION DIAGRAM FOR LOCATION OF WIRING CONNECTIONS.
- F.B.O. - FURNISHED BY OTHERS.
- ALL EXTERNAL WIRE FURNISHED BY OTHERS.
- N.D. = NORMALLY OPEN, N.C. = NORMALLY CLOSED, COMM. = COMMON.
- ALL WIRING MUST BE IN ACCORDANCE WITH NATIONAL AND LOCAL ELECTRICAL CODES.

SEE NOTES 2 AND 3

500 FT. (150 METERS)

1/C #14 (2.5 mmsq)

DRAWN BY K SCHILLER CHK BY R GIBSON DES. APVL J CAMPBELL	SHEET NO 1 OF 1 ECN NO REF. DWG.	TITLE CONTROL WIRE LIST EXTERNAL INTERCONNECTIONS MULTI - MODULE SYSTEM ALARM STATUS CONTACTS OPTION SERIES 600T	DWG. NO. 96-797619-128 REV. NO. 3	DATE 08/23/00 ORDER NO.
---	---	---	--	-------------------------------



FILE NAME: 96-797619-128-03.DWG

**Figure 43 Option Wiring, Maintenance Bypass Interlock**

WIRE NO.	TERMINAL DESIGNATION		SIGNAL NAME	MAXIMUM VOLTAGE	MAXIMUM CURRENT	COLOR	WIRE SIZE & TYPE	MAX. LENGTH	REMARKS
	FROM	TO							
CABLE GROUP #7 FROM I10 IN SYSTEM CONTROL CABINET TO OPTIONAL MAINTENANCE BYPASS									
771	I10TB2-1	1	ON BYPASS N.D.	120VAC	5 A				
772	I10TB2-3	2	ON BYPASS COMM.	120VAC	5 A				
773	I10TB2-4	3	MBB EPD N.D.	120VAC	5 A				
774	I10TB2-6	4	MBB EPD COMM.	120VAC	5 A		1/C #14 (2.5 mmsq)	500 FT. (150 METERS)	
775	I10TB2-7	5	TRANSFER INHIBIT	120VAC	5 A				
777	I10TB2-8	6	TRANSFER INHIBIT	120VAC	5 A				

NOTES:

- EACH CABLE GROUP MUST BE RUN IN A SEPARATE STEEL RACEWAY TO PREVENT CONTROL SIGNAL INTERFERENCE.
- REFER TO SCC CONTROL CONNECTION LOCATION DIAGRAM FOR LOCATION OF WIRING CONNECTIONS.
- ALL EXTERNAL WIRE FURNISHED BY OTHERS.
- N.D. = NORMALLY OPEN, COMM. = COMMON.
- ALL WIRING MUST BE IN ACCORDANCE WITH NATIONAL AND LOCAL ELECTRICAL CODES.

DRAWN BY K SCHILLER	SHEET NO 1 OF 1	TITLE CONTROL WIRE LIST EXTERNAL INTERCONNECTIONS MULTI - MODULE SYSTEM MAINTENANCE BYPASS INTERLOCK OPTION SERIES 600T	DWG. NO. 96-797619-90	DATE 08/23/00
CHK BY R REYES	ECN NO		REV. NO.	ORDER NO.
DES APVL J CAMPBELL	REF. DWG.		3	

FILE NAME: 96-797619-90-03.DWG



**Figure 44 Option Wiring, Remote Status Panel Interface**

WIRE NO.	TERMINAL DESIGNATION		SIGNAL NAME	MAXIMUM VOLTAGE	MAXIMUM CURRENT	COLOR	WIRE SIZE & TYPE	MAX. LENGTH	REMARKS
	FROM	TO							
CABLE GROUP #4 FROM I5 IN SYSTEM CONTROL CABINET TO TBI IN OPTIONAL REMOTE STATUS PANEL									
721	I5TBI-1	TBI-1	LOAD ON UPS	24VDC	1 A		1/C #14 (2.5 mmsq)  500 FT. (150 METERS)		
722	I5TBI-2	TBI-2	LOAD ON BYPASS	24VDC	1 A				
723	I5TBI-3	TBI-3	BATTERY DISCHARGING	24VDC	1 A				
724	I5TBI-4	TBI-4	LOW BATTERY WARNING	24VDC	1 A				
725	I5TBI-5	TBI-5	OVERLOAD	24VDC	1 A				
726	I5TBI-6	TBI-6	AMBIENT OVERTEMP	24VDC	1 A				
727	I5TBI-7	TBI-7	SYSTEM SUMMARY ALARM	24VDC	1 A				
728	I5TBI-8	TBI-8	NEW ALARM	24VDC	1 A				
729	I5TBI-9	TBI-9	+ 24 VDC	24VDC	1 A				
730	I5TBI-10	TBI-10	GROUND	24VDC	1 A				

NOTES:

1. EACH CABLE GROUP MUST BE RUN IN A SEPARATE STEEL RACEWAY TO PREVENT CONTROL SIGNAL INTERFERENCE.
2. REFER TO SCC CONTROL CONNECTION LOCATION DIAGRAM FOR LOCATION OF WIRING CONNECTIONS.
3. ALL EXTERNAL WIRE FURNISHED BY OTHERS.
4. ALL WIRING MUST BE IN ACCORDANCE WITH NATIONAL AND LOCAL ELECTRICAL CODES.

DRAWN BY K SCHILLER		SHEET NO 1 OF 1		TITLE CONTROL WIRE LIST	
CHK BY R REYES		ECN NO		EXTERNAL INTERCONNECTIONS	
DES APVL J CAMPBELL		REF. DWG.		MULTI - MODULE SYSTEM	
				REMOTE STATUS PANEL OPTION	
				SERIES 600T	

DWG. NO. 96-797619-130	DATE 08/23/00
REV. NO. 2	ORDER NO.

  
 9650 JERONIMO RD.  
 IRVINE, CALIFORNIA 92618

FILE NAME: 96-797619-130-02.DWG

**Figure 45 Option Wiring, Internal Modem**

WIRE NO.	TERMINAL DESIGNATION		SIGNAL NAME	MAXIMUM VOLTAGE	MAXIMUM CURRENT	COLOR	WIRE SIZE & TYPE	MAX. LENGTH	REMARKS
	FROM	TO							
871	J5	F.B.D.	MODEM LINE COMM.	N/A	N/A		TELEPHONE CABLE		
			CABLE GROUP #13 FROM J5 IN SYSTEM CONTROL CABINET TO CUSTOMER CONNECTION (F.B.D.)						

NOTES:

1. EACH CABLE GROUP MUST BE RUN IN A SEPARATE STEEL RACEWAY TO PREVENT CONTROL SIGNAL INTERFERENCE.
2. REFER TO SCC CONTROL CONNECTION LOCATION DIAGRAM FOR LOCATION OF WIRING CONNECTIONS.
3. F.B.D. - FURNISHED BY OTHERS.
4. ALL EXTERNAL WIRE FURNISHED BY OTHERS.
5. ALL WIRING MUST BE IN ACCORDANCE WITH NATIONAL AND LOCAL ELECTRICAL CODES.

  

DRAWN BY C HUA	SHEET NO 1 OF 1	TITLE CONTROL WIRE LIST EXTERNAL INTERCONNECTIONS MULTI - MODULE SYSTEM INTERNAL MODEM OPTION SERIES 600T
CHK BY R REYES	ECN NO	
DES APVL J CAMPBELL	REF. DWG.	

DWG. NO. 96-797619-32	DATE 04/01/99
REV. NO. 4	ORDER NO.

FILE NAME: 96-797619-32-04.DWG



**Liebert**  
9650 JERONIMO RD.  
IRVINE, CALIFORNIA 92618



Figure 46 Option Wiring, Customer Alarm Interface, SCC with Momentary-Duty Static Switch

WIRE NO.	TERMINAL DESIGNATION		SIGNAL NAME	MAXIMUM VOLTAGE	MAXIMUM CURRENT	COLOR	WIRE SIZE & TYPE	MAX. LENGTH	REMARKS
	FROM	TO							
CABLE GROUP #9 FROM I15 TB1 & TB2 IN SYSTEM CONTROL CABINET TO CUSTOMER CONNECTION (F.B.D.)									
781	I15TB1-1	N.D.	PROGRAMMABLE (ALARM #1)	24VDC	100mA				
782	I15TB1-2	COMM.	PROGRAMMABLE (ALARM #1)	24VDC	100mA				
783	I15TB1-3	N.D.	PROGRAMMABLE (ALARM #2)	24VDC	100mA				
784	I15TB1-4	COMM.	PROGRAMMABLE (ALARM #2)	24VDC	100mA				
785	I15TB1-5	N.D.	PROGRAMMABLE (ALARM #3)	24VDC	100mA				
786	I15TB1-6	COMM.	PROGRAMMABLE (ALARM #3)	24VDC	100mA				
787	I15TB1-7	N.D.	PROGRAMMABLE (ALARM #4)	24VDC	100mA				
788	I15TB1-8	COMM.	PROGRAMMABLE (ALARM #4)	24VDC	100mA				
789	I15TB1-9	N.D.	PROGRAMMABLE (ALARM #5)	24VDC	100mA				
790	I15TB1-10	COMM.	PROGRAMMABLE (ALARM #5)	24VDC	100mA				
791	I15TB2-1	N.D.	PROGRAMMABLE (ALARM #6)	24VDC	100mA				
792	I15TB2-2	COMM.	PROGRAMMABLE (ALARM #6)	24VDC	100mA				
793	I15TB2-3	N.D.	PROGRAMMABLE (ALARM #7)	24VDC	100mA				
794	I15TB2-4	COMM.	PROGRAMMABLE (ALARM #7)	24VDC	100mA				
795	I15TB2-5	N.D.	PROGRAMMABLE (ALARM #8)	24VDC	100mA				
796	I15TB2-6	COMM.	PROGRAMMABLE (ALARM #8)	24VDC	100mA				
							1/C #14 (2.5 mm <sup>2</sup> sq)	500 FT. (150 METERS)	

NOTES:

1. EACH CABLE GROUP MUST BE RUN IN A SEPARATE STEEL RACEWAY TO PREVENT CONTROL SIGNAL INTERFERENCE.
2. REFER TO SCC CONTROL CONNECTION LOCATION DIAGRAM FOR LOCATION OF WIRING CONNECTIONS.
3. F.B.D. - FURNISHED BY OTHERS.
4. ALL EXTERNAL WIRE FURNISHED BY OTHERS.
5. N.C. = NORMALLY OPEN, COMM. = COMMON.
6. ALL WIRING MUST BE IN ACCORDANCE WITH NATIONAL AND LOCAL ELECTRICAL CODES.

DRAWN BY C HUA	SHEET NO 1 OF 1	TITLE CONTROL WIRE LIST EXTERNAL INTERCONNECTIONS MULTI - MODULE SYSTEM (SCC WITH MOMENTARY DUTY STATIC SWITCH) CUSTOMER ALARM INTERFACE OPTION SERIES 600T	DWG. NO. 96-797619-28	DATE 08/23/00
CHK BY R REYES	ECN NO		REV. NO. 5	ORDER NO.
DES APVL J CAMPBELL	REF. DWG.			



FILE NAME: 96-797619-28-05.DWG

Figure 47 Option Wiring, Customer Alarm Interface, SCC with Continuous-Duty Static Switch

WIRE NO.	TERMINAL DESIGNATION FROM	TERMINAL DESIGNATION TO	SIGNAL NAME	MAXIMUM VOLTAGE	MAXIMUM CURRENT	COLOR	WIRE SIZE & TYPE	MAX. LENGTH	REMARKS
CABLE GROUP #9 FROM I15 IN SYSTEM CONTROL CABINET TO CUSTOMER CONNECTION (F.B.D.)									
789	I15TB1-9	N.D.	PROGRAMMABLE (ALARM #5)	24VDC	100mA		1/C #14 (2.5 mmsq)	500 FT. (150 METERS)	
790	I15TB1-10	COMM.	PROGRAMMABLE (ALARM #5)	24VDC	100mA				
791	I15TB2-1	N.D.	PROGRAMMABLE (ALARM #6)	24VDC	100mA				
792	I15TB2-2	COMM.	PROGRAMMABLE (ALARM #6)	24VDC	100mA				
793	I15TB2-3	N.D.	PROGRAMMABLE (ALARM #7)	24VDC	100mA				
794	I15TB2-4	COMM.	PROGRAMMABLE (ALARM #7)	24VDC	100mA				
795	I15TB2-5	N.D.	PROGRAMMABLE (ALARM #8)	24VDC	100mA				
796	I15TB2-6	COMM.	PROGRAMMABLE (ALARM #8)	24VDC	100mA				

DRAWN BY C HUA	SHEET NO 1 OF 1	TITLE CONTROL WIRE LIST EXTERNAL INTERCONNECTIONS MULTI - MODULE SYSTEM (SCC WITH CONTINUOUS DUTY STATIC SWITCH) CUSTOMER ALARM INTERFACE OPTION SERIES 600T	DWG. NO. 96-797619-111	DATE 08/23/00
CHK BY R REYES	ECN NO		REV. NO. 2	ORDER NO.
DES APVL J CAMPBELL	REF. DWG.		FILE NAME: 96-797619-111-023V6	

**Figure 48 Option Wiring, Battery Temperature Sensor**

WIRE NO.	TERMINAL DESIGNATION		SIGNAL NAME	MAXIMUM VOLTAGE	MAXIMUM CURRENT	COLOR	WIRE SIZE & TYPE	MAX. LENGTH	REMARKS
	FROM	TO							
	CABLE GROUP #15 FROM TB60 IN UPS MODULE TO OPTIONAL BATTERY TEMP SENSOR								
940	TB60-1	TB1-1	BATTERY TEMP. SENSOR	24VDC	100mA	WHITE	2/C #18 (10 mm <sup>2</sup> ) TWISTED PAIR SHIELDED	100 FT. (30 METERS)	BELDEN 8760 OR EQUAL
941	TB60-2	TB1-2	BATTERY TEMP. SENSOR	24VDC	100mA	BLACK			
942	TB60-3	---	SHIELD	24VDC	100mA	SHIELD			

NOTES:

1. EACH CABLE GROUP MUST BE RUN IN A SEPARATE STEEL RACEWAY TO PREVENT CONTROL SIGNAL INTERFERENCE.
2. REFER TO UPS MODULE CONTROL CONNECTION LOCATION DIAGRAM FOR LOCATION OF WIRING CONNECTIONS.
3. ALL EXTERNAL WIRE FURNISHED BY OTHERS.
4. ALL WIRING MUST BE IN ACCORDANCE WITH NATIONAL AND LOCAL ELECTRICAL CODES.

DRAWN BY K. SCHILLER		SHEET NO 1 OF 1		TITLE CONTROL WIRE LIST EXTERNAL INTERCONNECTIONS MULTI - MODULE SYSTEM BATTERY TEMPERATURE SENSOR OPTION SERIES 600T	
CHK BY R. REYES		ECN NO		DWG. NO. 96-797619-62	DATE 08/23/00
DES. APVL J. CAMPBELL		REF. DWG.		REV. NO. 5	ORDER NO.

FILE NAME: 96-797619-62-05.DWG



Figure 49 Option Wiring, SNMP Interface

WIRE NO.	TERMINAL DESIGNATION		SIGNAL NAME	MAXIMUM VOLTAG	MAXIMUM CURRENT	COLOR	WIRE SIZE & TYPE	MAX. LENGTH	REMARKS
	FROM	TO							
---	CABLE GROUP #26 FROM J1 & J4 IN SYSTEM CONTROL CABINET TO CUSTOMER CONNECTION (F.B.O)								
---	J1	ETHERNET NETWORK CONNECTOR	ETHERNET NETWORK	N/A	N/A		TELEPHONE CABLE	LENGTH LIMITED BY INTERNET STANDARDS	
---	J4	SETUP PORT ON PC	SETUP	---	---				

NOTES:

- EACH CABLE GROUP MUST BE RUN IN A SEPARATE STEEL RACEWAY TO PREVENT CONTROL SIGNAL INTERFERENCE.
- REFER TO SCC CONTROL CONNECTION LOCATION DIAGRAM FOR LOCATION OF WIRING CONNECTIONS.
- F.B.O. - FURNISHED BY OTHERS.
- ALL EXTERNAL WIRE FURNISHED BY OTHERS.
- ALL WIRING MUST BE IN ACCORDANCE WITH NATIONAL AND LOCAL ELECTRICAL CODES.



9650 JERONIMO RD.  
IRVINE, CALIFORNIA 92618

DRAWN BY C HUA	SHEET NO 1 OF 1	TITLE CONTROL WIRE LIST EXTERNAL INTERCONNECTIONS MULTI - MODULE SYSTEM SNMP INTERFACE OPTION SERIES 600T	DWG. NO. 96-797619-91	DATE 04/01/99
CHK BY R REYES	ECN NO		REV. NO.	ORDER NO.
DES APVL J CAMPBELL	REF. DWG.		1	

FILE NAME: 96-797619-91-01.DWG

Figure 50 External Interconnections, Module 1/SCC, Cable Groups 21 and 22

WIRE NO.	TERMINAL DESIGNATION FROM TO	SIGNAL NAME	MAXIMUM VOLTAGE	MAXIMUM CURRENT	COLOR	WIRE SIZE & TYPE	MAX. LENGTH	REMARKS
CABLE GROUP #20 FROM IFM I8 & I9 IN UPS MODULE 1 TO IFM IM1 IN SYSTEM CONTROL CABINET								
101	I8TB1-1	OSC. SYNC.	24VDC	100mA	WHITE	2/C #18 (1.0 mmsq) TWISTED PAIR SHIELDED	100 FT. (30 METERS)	18/C TV PR SHD #18 (1.0 mmsq) BELDEN 9390 OR 7-2/C SHD #18 (1.0 mmsq) BELDEN 8760 OR EQUAL
102	I8TB1-2	OSC. SYNC.	24VDC	100mA	BLACK			
---	I8TB1-3	OSC. SYNC.	24VDC	100mA	SHIELD			
---	I8TB1-4	PHASE SYNC.	24VDC	100mA	SHIELD	2/C #18 (1.0 mmsq) TWISTED PAIR SHIELDED		
103	I8TB1-5	PHASE SYNC.	24VDC	100mA	BLACK			
104	I8TB1-6	PHASE SYNC.	24VDC	100mA	WHITE			
105	I8TB1-7	FREQUENCY CONTROL	24VDC	100mA	BLACK/WHITE	2/C #18 (1.0 mmsq) TWISTED PAIR SHIELDED		
---	I8TB1-8	FREQUENCY CONTROL	24VDC	100mA	SHIELD			
106	I8TB1-9	GROUND	24VDC	100mA		1/C #14 (2.5 mmsq)	100 FT. (30 METERS)	
107	I8TB1-10	EMD SUPPLY	24VDC	100mA				
108	I8TB1-11	MAJORITY FAIL	24VDC	100mA	WHITE	2/C #18 (1.0 mmsq) TWISTED PAIR SHIELDED		
109	I8TB1-12	MAJORITY FAIL	24VDC	100mA	BLACK			
---	I8TB1-13	MAJORITY FAIL	24VDC	100mA	SHIELD			
---	I9TB1-3	LINE DROP COMP.	24VDC	100mA	SHIELD	2/C #18 (1.0 mmsq) TWISTED PAIR SHIELDED	100 FT. (30 METERS)	18/C TV PR SHD #18 (1.0 mmsq) BELDEN 9390 OR 7-2/C SHD #18 (1.0 mmsq) BELDEN 8760 OR EQUAL
110	I9TB1-4	LINE DROP COMP.	24VDC	100mA	BLACK/WHITE			
---	I9TB1-5	VOLT CONTROL	24VDC	100mA	SHIELD			
111	I9TB1-6	VOLT CONTROL	24VDC	100mA	BLACK/WHITE	2/C #18 (1.0 mmsq) TWISTED PAIR SHIELDED		
---	I9TB1-8	CURRENT SHARE	24VDC	100mA	SHIELD			
112	I9TB1-9	CURRENT SHARE	24VDC	100mA	WHITE	2/C #18 (1.0 mmsq) TWISTED PAIR SHIELDED		
113	I9TB1-10	CURRENT SHARE	24VDC	100mA	BLACK			
CABLE GROUP #21 FROM IFM I7 & TB10 IN UPS MODULE 1 TO IFM I11 & I2 IN SYSTEM CONTROL CABINET								
114	I7TB1-1	COMMUNICATIONS	24VDC	100mA	WHITE	2/C #18 (1.0 mmsq) TWISTED PAIR SHIELDED	100 FT. (30 METERS)	BELDEN 8760 OR EQUAL
115	I7TB1-2	COMMUNICATIONS	24VDC	100mA	BLACK			
---	I7TB1-3	COMMUNICATIONS	24VDC	100mA	SHIELD			
116	ITB10-2	2 STEP BATTERY LIMIT	24VDC	100mA		1/C #14 (2.5 mmsq)	100 FT. (30 METERS)	
117	ITB10-1	2 STEP BATTERY LIMIT	24VDC	100mA				

NOTES:

- EACH CABLE GROUP MUST BE RUN IN A SEPARATE STEEL RACEWAY TO PREVENT CONTROL SIGNAL INTERFERENCE.
- REFER TO UPS MODULE / SCC CONTROL CONNECTION LOCATION DIAGRAM FOR LOCATION OF WIRING CONNECTIONS.
- ALL EXTERNAL WIRE FURNISHED BY OTHERS.
- ALL WIRING MUST BE IN ACCORDANCE WITH NATIONAL AND LOCAL ELECTRICAL CODES.

DRAWN BY C HUA	SHEET NO 1 OF 1	CONTROL WIRE LIST EXTERNAL INTERCONNECTIONS MULTI - MODULE SYSTEM MODULE 1 / SCC - CABLE GROUPS 20 AND 21 SERIES 600T		DWG. NO.	DATE
CHK BY R REYES	ECN NO			96-797619-52	08/23/00
DES APVL J CAMPBELL	REF. DWG.			REV. NO.	ORDER NO.
				5	



FILE NAME: 96-797619-52-05.DWG

**Figure 51 External Interconnections, Module 2/SCC, Cable Groups 21 and 22**

WIRE NO.	TERMINAL DESIGNATION		SIGNAL NAME	MAXIMUM VOLTAGE	MAXIMUM CURRENT	COLOR	WIRE SIZE & TYPE	MAX. LENGTH	REMARKS
	FROM	TO							
CABLE GROUP #20 FROM IFM I8 & I9 IN UPS MODULE 2 TO IFM IM2 IN SYSTEM CONTROL CABINET									
201	I8TB1-1	IM2TB1-1	DSC. SYNC.	24VDC	100mA	WHITE	2/C #18 (1.0 mmsq) TWISTED PAIR SHIELDED	100 FT. (30 METERS)	18/C TV PR SHD #18 (1.0 mmsq) BELDEN 9390 OR 7-2/C SHD #18 (1.0 mmsq) BELDEN 8760 OR EQUAL
202	I8TB1-2	IM2TB1-2	DSC. SYNC.	24VDC	100mA	BLACK			
---	I8TB1-3	IM2TB1-3	DSC. SYNC.	24VDC	100mA	SHIELD			
---	I8TB1-4	IM2TB1-4	PHASE SYNC.	24VDC	100mA	SHIELD			
203	I8TB1-5	IM2TB1-5	PHASE SYNC.	24VDC	100mA	BLACK	2/C #18 (1.0 mmsq) TWISTED PAIR SHIELDED		
204	I8TB1-6	IM2TB1-6	PHASE SYNC.	24VDC	100mA	WHITE			
205	I8TB1-7	IM2TB1-7	FREQUENCY CONTROL	24VDC	100mA	BLACK/WHITE	2/C #18 (1.0 mmsq) TWISTED PAIR SHIELDED		
---	I8TB1-8	IM2TB1-8	FREQUENCY CONTROL	24VDC	100mA	SHIELD			
206	I8TB1-9	IM2TB1-9	GROUND	24VDC	100mA		1/C #14 (2.5 mmsq)	100 FT. (30 METERS)	
207	I8TB1-10	IM2TB1-10	EMD SUPPLY	24VDC	100mA				
208	I8TB1-11	IM2TB1-11	MAJORITY FAIL	24VDC	100mA	WHITE			
209	I8TB1-12	IM2TB1-12	MAJORITY FAIL	24VDC	100mA	BLACK			
---	I8TB1-13	IM2TB1-13	MAJORITY FAIL	24VDC	100mA	SHIELD			
---	I9TB1-3	IM2TB1-19	LINE DROP COMP.	24VDC	100mA	SHIELD	2/C #18 (1.0 mmsq) TWISTED PAIR SHIELDED		18/C TV PR SHD #18 (1.0 mmsq) BELDEN 9390 OR 7-2/C SHD #18 (1.0 mmsq) BELDEN 8760 OR EQUAL
210	I9TB1-4	IM2TB1-20	LINE DROP COMP.	24VDC	100mA	BLACK/WHITE	2/C #18 (1.0 mmsq) TWISTED PAIR SHIELDED		
---	I9TB1-5	IM2TB1-21	VOLT CONTROL	24VDC	100mA	SHIELD			
211	I9TB1-6	IM2TB1-22	VOLT CONTROL	24VDC	100mA	BLACK/WHITE	2/C #18 (1.0 mmsq) TWISTED PAIR SHIELDED		
---	I9TB1-8	IM2TB1-24	CURRENT SHARE	24VDC	100mA	SHIELD			
212	I9TB1-9	IM2TB1-25	CURRENT SHARE	24VDC	100mA	WHITE			
213	I9TB1-10	IM2TB1-26	CURRENT SHARE	24VDC	100mA	BLACK			
CABLE GROUP #21 FROM IFM I7 & TB10 IN UPS MODULE 2 TO IFM I11 & I2 IN SYSTEM CONTROL CABINET									
214	I7TB1-1	I11TB1-11	COMMUNICATIONS	24VDC	100mA	WHITE	2/C #18 (1.0 mmsq) TWISTED PAIR SHIELDED	100 FT. (30 METERS)	BELDEN 8760 OR EQUAL
215	I7TB1-2	I11TB1-10	COMMUNICATIONS	24VDC	100mA	BLACK			
---	I7TB1-3	I11TB1-13	COMMUNICATIONS	24VDC	100mA	SHIELD			
216	TB10-2	I2TB2-3	2 STEP BATTERY LIMIT	24VDC	100mA				
217	TB10-1	I2TB2-4	2 STEP BATTERY LIMIT	24VDC	100mA		1/C #14 (2.5 mmsq)	100 FT. (30 METERS)	

**NOTES:**

1. EACH CABLE GROUP MUST BE RUN IN A SEPARATE STEEL RACEWAY TO PREVENT CONTROL SIGNAL INTERFERENCE.
2. REFER TO UPS MODULE / SCC CONTROL CONNECTION LOCATION DIAGRAM FOR LOCATION OF WIRING CONNECTIONS.
3. ALL EXTERNAL WIRE FURNISHED BY OTHERS.
4. ALL WIRING MUST BE IN ACCORDANCE WITH NATIONAL AND LOCAL ELECTRICAL CODES.

DRAWN BY C. HUA	SHEET NO 1 OF 1		TITLE CONTROL WIRE LIST EXTERNAL INTERCONNECTIONS MULTI - MODULE SYSTEM MODULE 2 / SCC - CABLE GROUPS 20 AND 21 SERIES 600T	
	CHK BY R. REYES	ECN NO	DWG. NO. 96-797619-53	DATE 08/23/00
DES APVL J. CAMPBELL	REF. DWG.	REV. NO. 5	ORDER NO.	



FILE NAME: 96-797619-53-05.DWG

Figure 52 Wiring Configurations, UPS Video Display Terminal

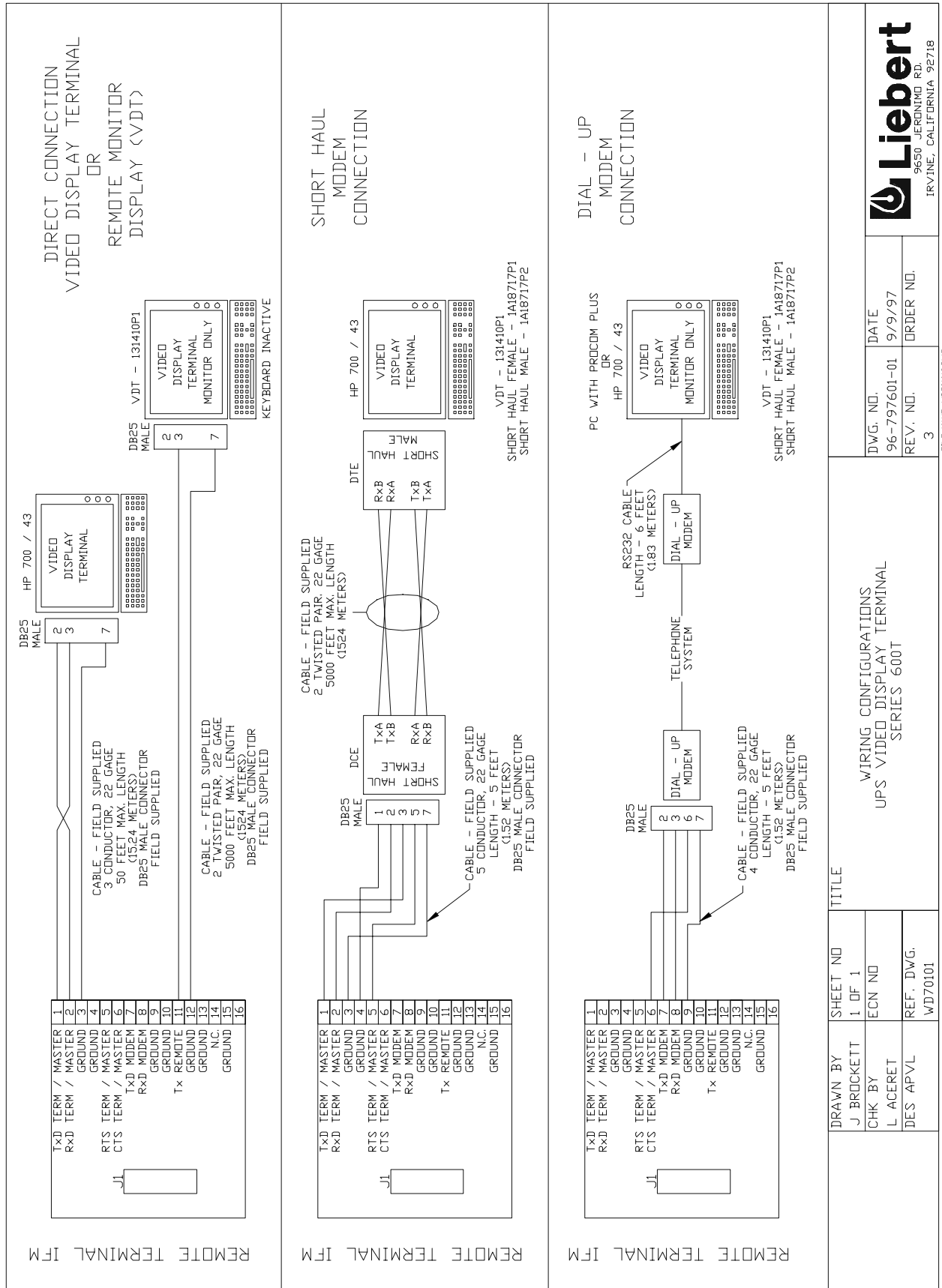

**Liibert**  
9650 JERONIMO RD.  
IRVINE, CALIFORNIA 92718

DWG. NO. 96-797601-01  
REV. NO. 3  
DATE 9/9/97  
ORDER NO.

WIRING CONFIGURATIONS  
UPS VIDEO DISPLAY TERMINAL  
SERIES 600T

TITLE

DRAWN BY SHEET NO  
J BROCKETT 1 OF 1

CHK BY ECN NO  
L ACERET

DES APVL REF. DWG.  
WD70101

FILE NAME: WD70103.DWG

Figure 53 Module Battery Disconnect, 600-1200 Amps, without Input Isolation Transformer

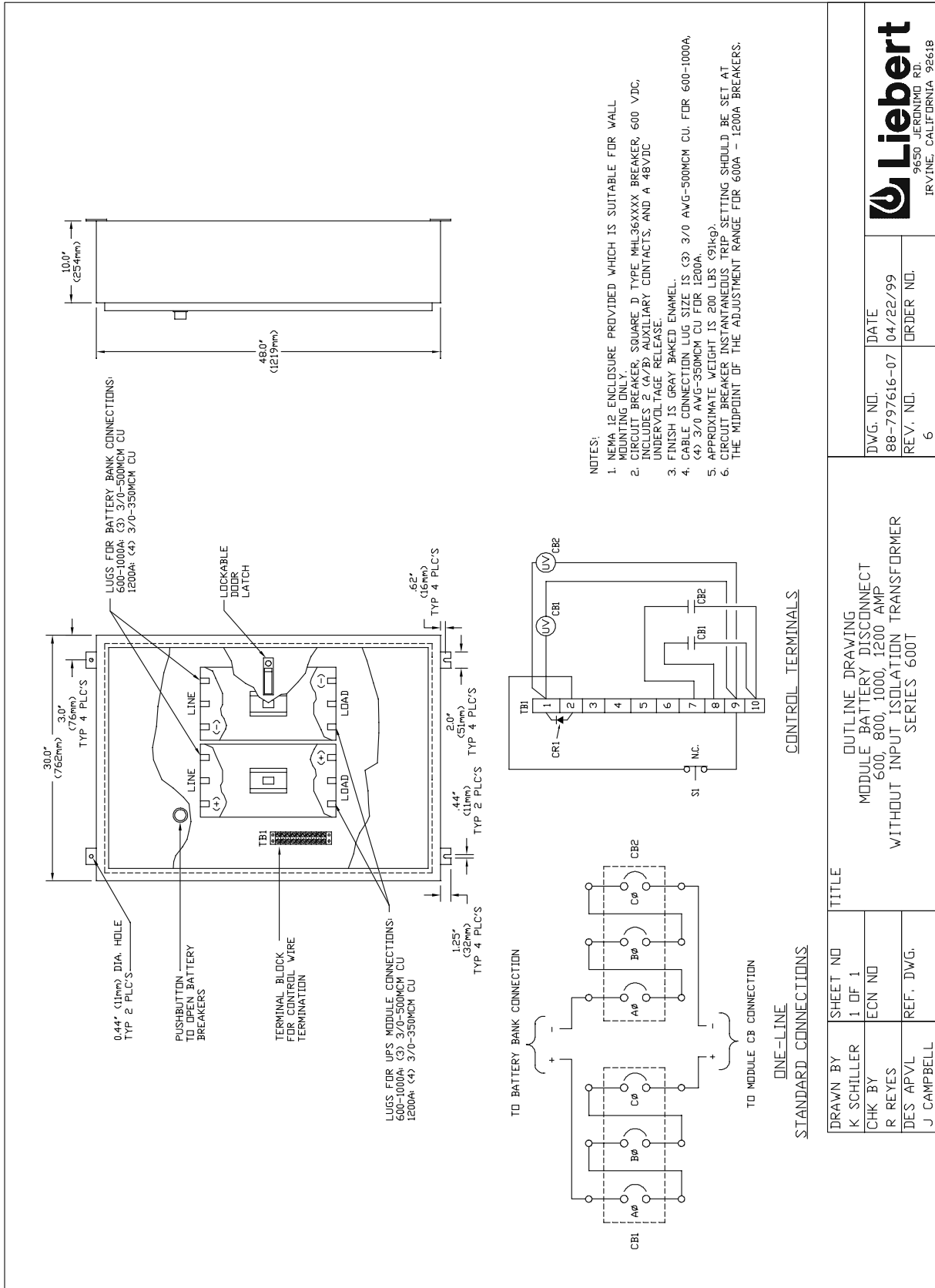

9650 JERDIND RD.  
IRVINE, CALIFORNIA 92618

DWG. NO.	DATE
88-797616-07	04/22/99
REV. NO.	ORDER NO.
6	
FILE NAME: 88-797616-07-06.DWG	
TITLE OUTLINE DRAWING MODULE BATTERY DISCONNECT 600, 800, 1000, 1200 AMP WITHOUT INPUT ISOLATION TRANSFORMER SERIES 600T	
DRAWN BY	SHEET NO
K SCHILLER	1 OF 1
CHK BY	ECN NO
R REYES	
DES APVL	REF. DWG.
J CAMPBELL	



Figure 54 Module Battery Disconnect, 300-1200 Amps, with Input Isolation Transformer

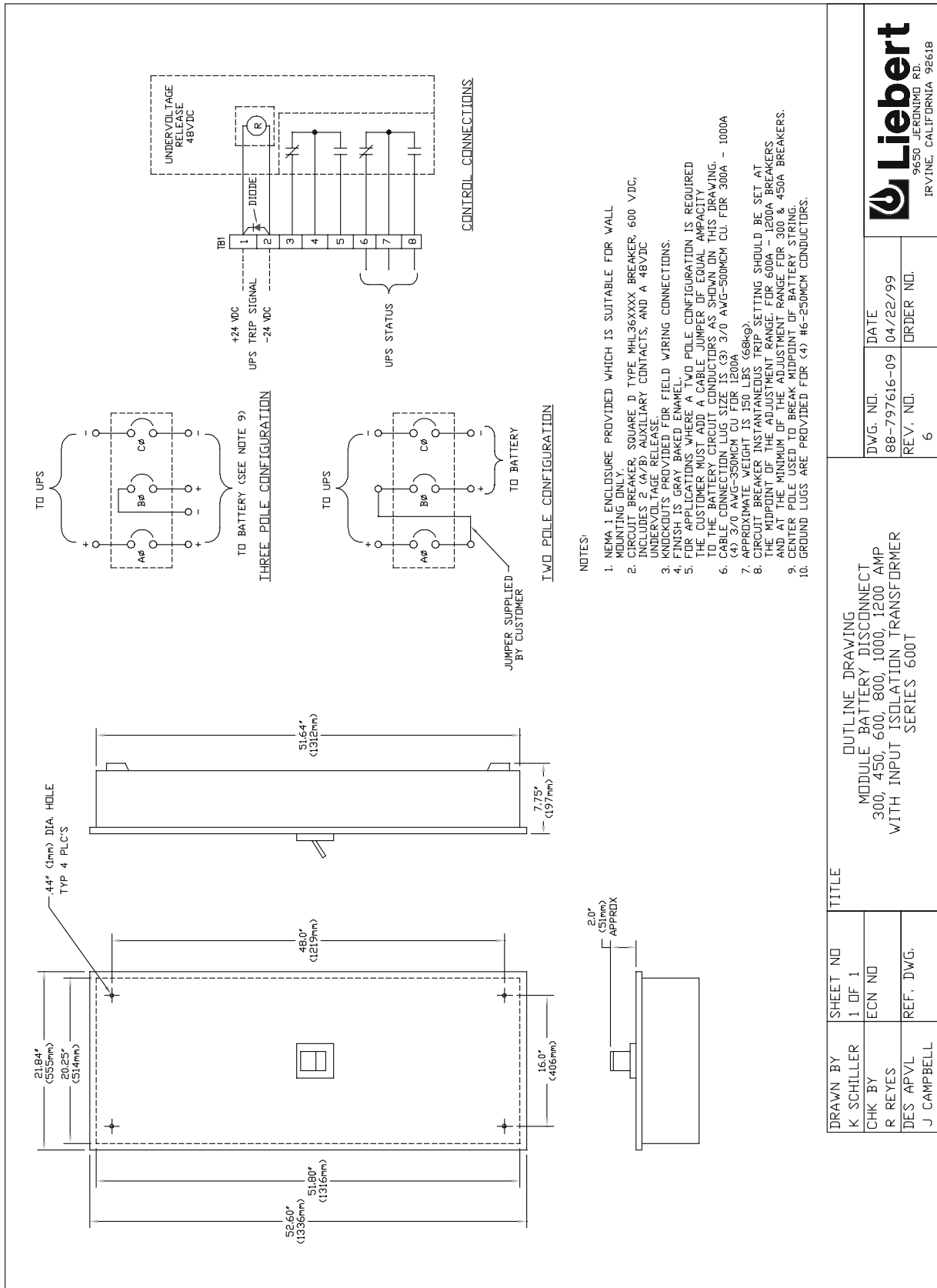

**Figure 55 Remote Status Panel, Surface Mount**

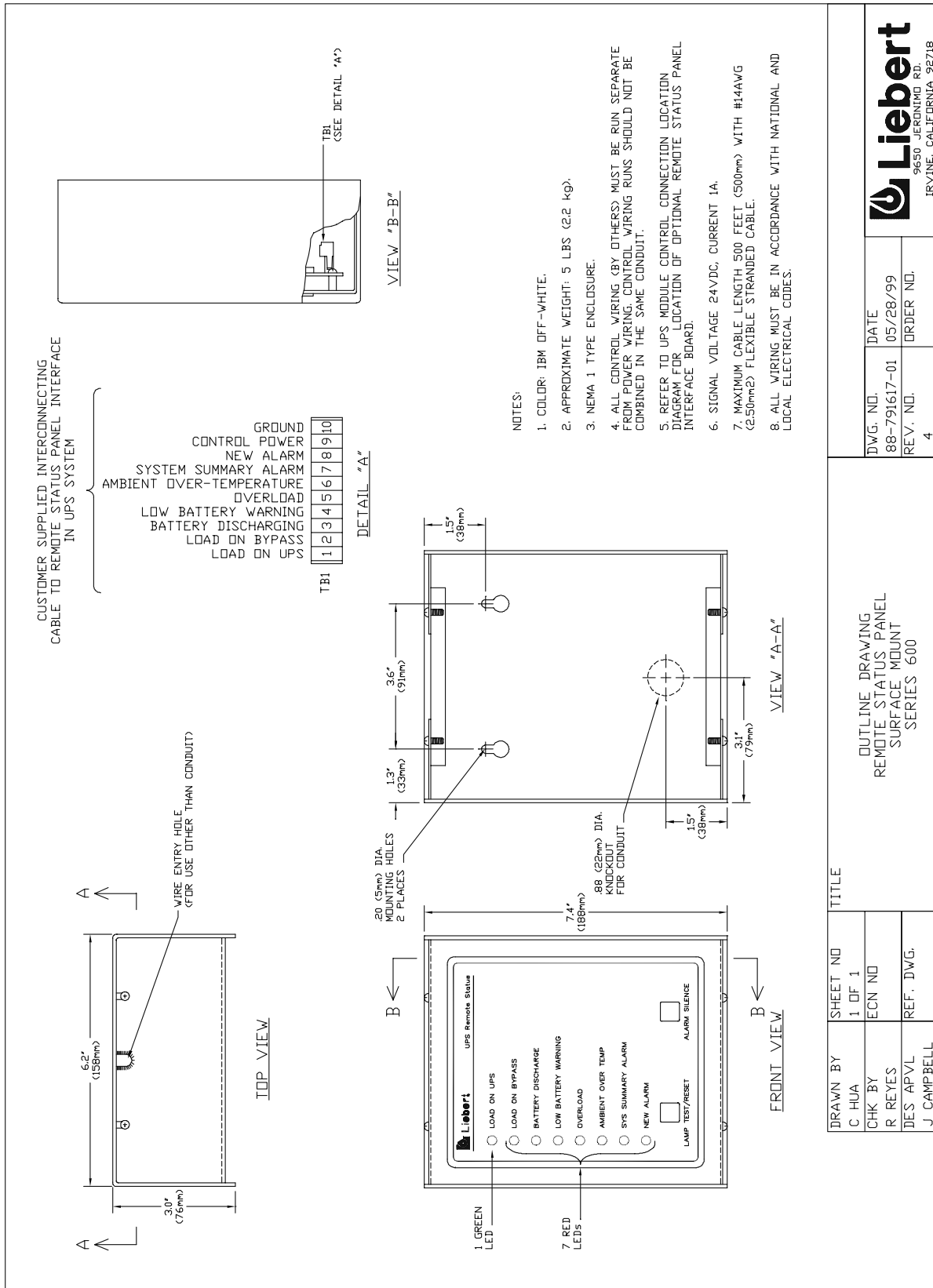

DRAWN BY C HUA		SHEET NO 1 OF 1		TITLE OUTLINE DRAWING REMOTE STATUS PANEL SURFACE MOUNT SERIES 600	
CHK BY R REYES		ECN NO		DWG. NO. 88-791617-01	
DES APVL J CAMPBELL		REF. DWG.		DATE 05/28/99	
				REV. NO. 4	
				ORDER NO.	
				FILE NAME: 88-791617-01-04.DWG	



Figure 56 Circuit Breaker Schedule, Multi-Module UPS, 300-750 kVA

SERIES 600T MULTI - MODULE CIRCUIT BREAKER SCHEDULE											
		INPUT CIRCUIT BREAKER (CB1)				OUTPUT CIRCUIT BREAKER (CB2)					
USAGE KVA/KW	VOLTAGE IN	VENDOR	TYPE	INTERRUPTING RATING AIC	VOLTAGE IN	VENDOR	TYPE	INTERRUPTING RATING AIC		TYPE	INTERRUPTING RATING AIC
300/240	208V	SQUARE D	MHL	65K	208V	SQUARE D	MHL	65K		MHL	65K
	480V		MHL	65K			MHL	65K			
	600V		MHL	25K			MHL	25K			
400/320	208V (1)	SQUARE D	MHL	65K	208V	MERLIN GERIN	CKHH	100K		CKHH	100K
	480V		MHL	65K			MHL	65K			
	600V		MHL	25K			MHL	25K			
400/360	480V	SQUARE D	MHL	65K	480V	SQUARE D	MHL	65K		MHL	65K
450/360	480V	SQUARE D	MHL	65K	480V	SQUARE D	MHL	65K		MHL	65K
500/400	480V 600V	SQUARE D	MHL MHL	65K 25K	480V 600V	SQUARE D	MHL MHL	65K 25K		MHL MHL	65K 25K
500/450	480V 600V	SQUARE D	MHL MHL	65K 25K	480V 600V	SQUARE D	MHL MHL	65K 25K		MHL MHL	65K 25K
625/500	480V 600V	SQUARE D	MHL MHL	65K 25K	480V 600V	SQUARE D	MHL MHL	65K 25K		MHL MHL	65K 25K
750/600	480V 600V	SQUARE D	MHL MHL	65K 25K	480V 600V	SQUARE D	MHL MHL	65K 25K		MHL MHL	65K 25K
750/675	480V 600V	MERLIN GERIN	CKHH CKHH	65K 42K	480V 600V	MERLIN GERIN	CKHH CKHH	65K 42K		CKHH CKHH	65K 42K

NOTES:

- 400KVA 208V INPUT/OUTPUT USES AN INPUT TRANSFORMER CABINET FOR 208V TO 480V CONVERSION.  
THE UPS MODULE IS 480V/208V.

DRAWN BY K SCHILLER	SHEET NO 1 OF 1	TITLE CIRCUIT BREAKER SCHEDULE		DWG. NO. 84-797605-113	DATE 04/07/00
	CHK BY R REYES	ECN NO	MULTI - MODULE UPS 300 - 750 KVA SERIES 600T		
DES APVL J CAMPBELL	REF. DWG.			REV. NO. 2	



Figure 57 Circuit Breaker Schedule, Merlin-Gerin Breakers, SCCT, 200-4000 Amps

SYSTEM CONTROL CABINET (SCCT) 200 - 4000 AMP CIRCUIT BREAKER SCHEDULE									
SCCT CONTINUOUS AMPERES	BREAKER DESIGNATION	VENDOR	TYPE	FRAME AMPS	TRIP AMPS	AIC@ 240V	AIC@ 480V	AIC@ 600V	
200			CJ400H	400	250	100K	42K	25K	
280			CJ400H	400	350	100K	42K	25K	
360			CJ600H	600	450	100K	42K	25K	
480			CJ600H	600	600	100K	42K	25K	
560			CK800H	700	700	100K	65K	42K	
640			CK800H	800	800	100K	65K	42K	
800			CK1200H	1200	1000	100K	65K	42K	
960			CK1200H	1200	1200	100K	65K	42K	
1000			CK1200HH	1200	1000	100K	65K	42K	
1200			CK1200HH	1200	1200	100K	65K	42K	
1600			MP16H2	1600	1600	100K	100K	65K	
2000			MP20H2	2000	2000	100K	100K	75K	
2500			MP25H2	2500	2500	100K	100K	75K	
3000			MP30H2	3000	3000	100K	100K	75K	
4000			MP40H1	4000	4000	100K	100K	100K	

DRAWN BY C HUA		SHEET NO 1 OF 1		TITLE CIRCUIT BREAKER SCHEDULE MERLIN GERIN SYSTEM CONTROL CABINET (SCCT) 200 - 4000 AMP SERIES 600T		DWG. NO. 84-797605-115		DATE 09/15/99	
CHK BY R REYES		ECN NO				REV. NO. 2		ORDER NO.	
DES APVL J CAMPBELL		REF. DWG.				FILE NAME: 84-797605-115-02.DWG		 9650 JERONIMO RD. IRVINE, CALIFORNIA 92618	

Figure 58 Circuit Breaker Schedule, General Electric Breakers, SCCT, 200-4000 Amps

SYSTEM CONTROL CABINET (SCCT) 1600 - 4000 AMP CIRCUIT BREAKER SCHEDULE									
SCCT CONTINUOUS AMPERES	BREAKER DESIGNATION	VENDOR	TYPE	FRAME AMPS	TRIP AMPS	AIC@ 240V	AIC@ 480V	AIC@ 600V	
1600			SSD16	1600	1600	85K	65K	50K	
2000			SSD20	2000	2000	85K	65K	50K	
2500		GENERAL ELECTRIC	SSD25	2500	2500	100K	100K	85K	
3000			SSD30	3000	3000	100K	100K	85K	
4000			SSD40	4000	4000	100K	100K	85K	

DRAWN BY C HUA	SHEET NO 1 OF 1	TITLE CIRCUIT BREAKER SCHEDULE GENERAL ELECTRIC SYSTEM CONTROL CABINET (SCCT)	DWG. NO. 84-797605-116	DATE 09/15/99
CHK BY R REYES	ECN NO	1600 - 4000 AMP SERIES 600T	REV. NO. 1	ORDER NO.
DES APVL J CAMPBELL	REF. DWG.			

  

<b>Liibert</b> 9650 JERONIMO RD. IRVINE, CALIFORNIA 92618	
---	--

FILE NAME: 84-797605-116-01.DWG

## 12.0 APPENDIX A - SITE PLANNING DATA

### 500-750kVA Multi-Module Systems

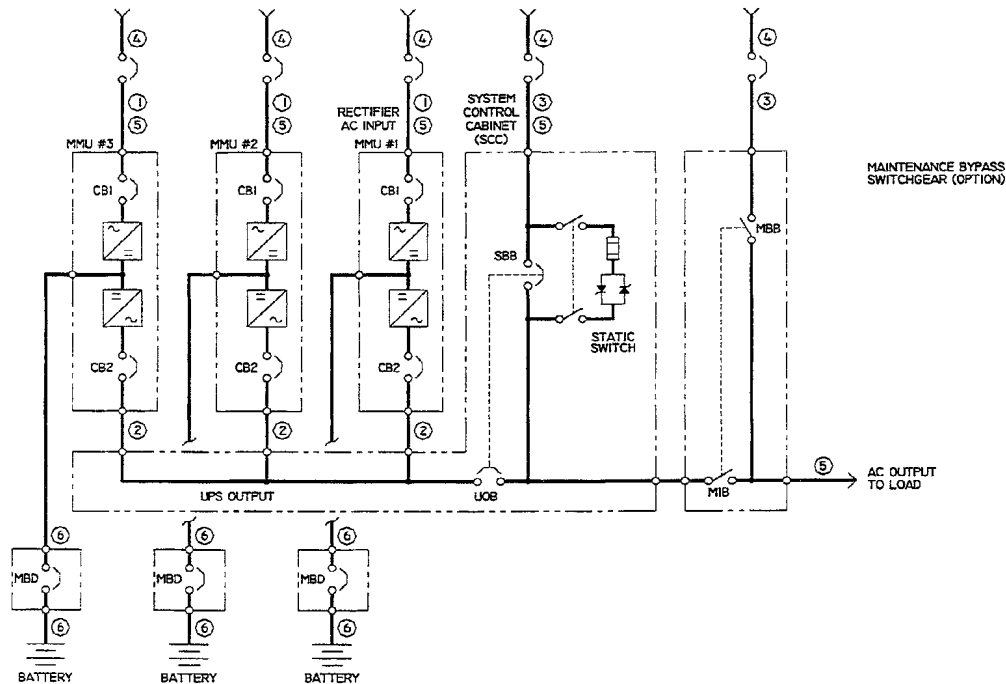

### 12.1 Notes

1. Nominal rectifier AC input current (considered continuous) is based on full rated output load. Maximum current includes nominal input current and maximum battery recharge current (considered noncontinuous). Continuous and noncontinuous current limit are defined in NEC 100. Maximum input current is controlled by current limit setting which is adjustable. Values shown are for maximum setting of 125%. Standard factory setting is 115%.
2. Nominal AC output current (considered continuous) is based on full rated output load. Maximum current includes nominal output current and overload for 10 minutes.
3. Bypass AC input current (considered continuous) is based on full rated output load.
4. Feeder protection (by others in external equipment) for rectifier AC input and bypass AC input is recommended to be provided by separate overcurrent protection devices.
5. UPS output load cables must be run in separate conduit from input cables.
6. Power cable from module DC bus to battery should be sized for a total maximum 2.0 volt line drop (measured at the module) at maximum discharge current.
7. Grounding conductors to be sized per NEC 250-122. Neutral conductors to be sized for full capacity for systems with 4-wire loads and half capacity for systems with 3-wire loads. NOTE: A neutral conductor is required from each Multi-Module Unit output to the System Control Cabinet.
8. Rectifier AC Input: 3-phase, 3-wire, plus ground  
AC Output, SCC to Load: 3-phase, 3 or 4-wire, plus ground  
Bypass AC Input: 3-phase, 3 or 4-wire, plus ground  
Module DC Input from Battery: 2-wire, (positive and negative)
9. All wiring is to be in accordance with National and Local Electrical Codes.
10. Minimum clearance is 2 feet above UPS.
11. Top or bottom cable entry through removable access plates. Cut plate to suit conduit size.
12. Control wiring and power cables must be run in separate conduits. Control wiring must be stranded tinned conductors.
13. 7% maximum input harmonic current and 0.92 lagging input power factor at full load with 6-pulse rectifier and optional input filter (4% with 12-pulse rectifier and input filter).  
30% maximum input harmonic current and 0.85 lagging input power factor at full load without optional input filter (9% with 12-pulse rectifier).
14. Dimensions and weights do not include the System Control Cabinet required for Multi-Module Systems.

**Table 4 Series 600T Multi-Module Systems, 500-750 kVA - 480 Volt Input**

UPS Rating		AC Output Voltage	Options		Rectifier AC Input Current		Inverter or Bypass AC Output Current		Required Battery Disconnect Rating	Maximum Battery Current at End of Discharge	Maximum Heat Dissipation BTU/hr.	Dimensions Inches	Approx. Weight Lb.	Floor Loading Lb./Sq.ft.
kVA	kW		Input Filter	Input Iso Xfmr	Nom	Max	Nom	Max	Amps	Amps	Full Load	(WxDxH)	(Un-packed)	(Concentrated Loading)
500	400	480	NO	NO	602	753	601	752	1,000	1,079	87,150	72x39x79	5,710	293
500	400	480	YES	NO	558	698	601	752	1,000	1,079	91,800	72x39x79	5,910	303
500	400	480	NO	YES	612	765	601	752	1,000	1,079	110,700	96x39x79	8,710	335
500	400	480	YES	YES	565	707	601	752	1,000	1,079	115,500	96x39x79	8,910	343
500	450	480	NO	NO	677	847	601	752	1,200	1,214	98,050	72x39x79	5,730	294
500	450	480	YES	NO	628	785	601	752	1,200	1,214	103,250	72x39x79	5,930	304
500	450	480	NO	YES	688	861	601	752	1,200	1,214	124,550	96x39x79	9,030	347
500	450	480	YES	YES	638	798	601	752	1,200	1,214	129,931	96x39x79	9,230	355
625	500	480	NO	NO	749	936	752	936	1,400	1,349	99,300	108x39x79	7,405	285
625	500	480	YES	NO	694	867	752	936	1,400	1,349	105,050	108x39x79	7,625	293
625	500	480	NO	YES	757	946	752	936	1,400	1,349	118,650	120x39x79	10,485	323
625	500	480	YES	YES	701	877	752	936	1,400	1,349	124,509	120x39x79	10,705	329
750	600	480	NO	NO	898	1123	902	1128	1,600	1,619	119,200	108x39x79	8,005	308
750	600	480	YES	NO	833	1041	902	1128	1,600	1,619	126,100	108x39x79	8,225	316
750	600	480	NO	YES	908	1135	902	1128	1,600	1,619	142,350	120x39x79	11,485	353
750	600	480	YES	YES	842	1052	902	1128	1,600	1,619	149,410	120x39x79	11,705	360
750	675	480	NO	YES	1022	1277	902	1128	1,600	1,822	160,150	120x39x79	11,785	363
750	675	480	YES	YES	947	1184	902	1128	1,600	1,822	168,100	120x39x79	12,005	369
<b>Applicable Notes:</b>		—	13	—	1,4,5,7,8,9,11,12		2,3,5,7,8,9,11,12		6	6,8,9,11,12	—	14	14	—
For explanation of notes, see referenced numbers in <b>12.1 - Notes</b>														

**Table 5 Series 600T Multi-Module Systems, 500-750 kVA - 600 Volt Input**

UPS Rating		AC Output Voltage	Options		Rectifier AC Input Current		Inverter or Bypass AC Output Current		Required Battery Disconnect Rating	Maximum Battery Current at End of Discharge	Maximum Heat Dissipation BTU/hr.	Dimensions Inches	Approx. Weight Lb.	Floor Loading Lb./Sq.ft.
kVA	kW		Input Filter	Input Xfmr	Nom	Max	Nom	Max	Amps	Amps	Full Load	(WxDxH)	(Un-packed)	(Concentrated Loading)
500	400	600	NO	NO	484	605	481	601	1,000	1,079	94,900	72x39x79	6,110	313
500	400	600	YES	NO	449	561	481	601	1,000	1,079	99,600	72x39x79	6,310	324
500	400	600	NO	YES	490	612	481	601	1,000	1,079	110,700	96x39x79	8,710	355
500	400	600	YES	YES	454	567	481	601	1,000	1,079	115,500	96x39x79	8,910	343
500	450	600	NO	NO	545	681	481	601	1,200	1,214	106,750	72x39x79	6,130	314
500	450	600	YES	NO	505	631	481	601	1,200	1,214	112,050	72x39x79	6,330	325
500	450	600	NO	YES	551	688	481	601	1,200	1,214	124,550	96x39x79	9,030	347
500	450	600	YES	YES	510	638	481	601	1,200	1,214	129,950	96x39x79	9,230	355
625	500	600	NO	NO	602	753	601	752	1,400	1,349	108,950	108x39x79	7,805	300
625	500	600	YES	NO	559	699	601	752	1,400	1,349	118,650	108x39x79	8,025	309
625	500	600	NO	YES	609	761	601	752	1,400	1,349	128,450	120x39x79	10,485	323
625	500	600	YES	YES	554	705	601	752	1,400	1,349	134,400	120x39x79	10,705	329
750	600	600	NO	NO	723	903	722	902	1,600	1,619	130,700	108x39x79	8,405	323
750	600	600	YES	NO	671	839	722	902	1,600	1,619	142,350	108x39x79	8,625	332
750	600	600	NO	YES	730	913	722	902	1,600	1,619	154,150	120x39x79	11,485	353
750	600	600	YES	YES	677	846	722	902	1,600	1,619	161,250	120x39x79	11,705	360
750	675	600	NO	YES	822	1027	722	902	1,600	1,822	173,400	120x39x79	11,785	363
750	675	600	YES	YES	762	952	722	902	1,600	1,822	181,400	120x39x79	12,005	369
<b>Applicable Notes:</b>		—	13	—	1,4,5,7,8,9,11,12		2,3,5,7,8,9,11,12		6	6,8,9,11,12	—	14	14	—

For explanation of notes, see referenced numbers in **12.1 - Notes**



## 13.0 APPENDIX B - FIELD SUPPLIED LUGS

**Table 6 One-Hole Lugs**

T & B <sup>1</sup> Lug Style		Wire Size	Bolt Size (Inches)	Tongue Width (Inches)	T & B <sup>1</sup> P/N	Liebert P/N
1	<b>Stak-On</b>	1/0 AWG	3/8	0.88	J973	12-714255-56
2		2/0 AWG	3/8	1.00	K973	12-714255-66
3		3/0 AWG	3/8	1.10	L973	12-714255-76
4		4/0 AWG	3/8	1.20	M973	12-714255-86
5	<b>Color-Keyed Aluminum/ Copper</b>	1/0 AWG	3/8	0.93	60130	—
6		2/0 AWG	3/8	0.97	60136	—
7		3/0 AWG	3/8	1.06	60142	—
8	<b>Color-Keyed Copper Cable Long Barrel</b>	1/0 AWG	3/8	0.75	54909BE	—
9		2/0 AWG	3/8	0.81	54910BE	—
10		3/0 AWG	1/2	0.94	54965BE	—
11		4/0 AWG	1/2	1.03	54970BE	—
12		250MCM	1/2	1.09	54913BE	—
13	<b>Narrow-Tongue Copper Cable</b>	350MCM	1/2	1.09	55165	—
14		500MCM	1/2	1.20	55171	—

<sup>1</sup> NOTE: Manufacturer Thomas & Betts (T & B), 1-800-862-8324





## **Series 600T™ UPS**

**Multi-Module Three Phase**

**500 kVA to 750kVA; 60 Hz**

### **Technical Support**

U.S.A.	1-800-222-5877
Outside the U.S.A.	614-841-6755
U.K.	+44 (0) 1793 553355
France	+33 1 4 87 51 52
Germany	+49 89 99 19 220
Italy	+39 2 98250 1
Netherlands	+00 31 475 503333
E-mail	upstech@liebert.com
Web site	<a href="http://www.liebert.com">http://www.liebert.com</a>
Worldwide FAX	614-841-5471
tech support	

### **The Company Behind The Products**

With more than 500,000 installations around the globe, Liebert is the world leader in computer protection systems. Since its founding in 1965, Liebert has developed a complete range of support and protection systems for sensitive electronics:

- Environmental systems: close-control air conditioning from 1.5 to 60 tons.
- Power conditioning and UPS with power ranges from 250 VA to more than 1000 kVA.
- Integrated systems that provide both environmental and power protection in a single, flexible package.
- Monitoring and control — on-site or remote — from systems of any size or location

Service and support, through more than 100 service centers around the world, and a 24-hour Customer Response Center.

While every precaution has been taken to ensure accuracy and completeness of this literature, Liebert Corporation assumes no responsibility, and disclaims all liability for damages resulting from use of this information or for any errors or omissions.

© 2000 Liebert Corporation. All rights reserved throughout the world. Specifications subject to change without notice.

® Liebert and the Liebert logo are registered trademarks of Liebert Corporation. All names referred to are trademarks or registered trademarks of their respective owners.

Printed in U.S.A.

SL-30531